

The right choice for the ultimate yield!

LS ELECTRIC strives to maximize your profits in gratitude for choosing us as your partner.

Programmable Logic Control

Resistance Temperature Detector Module

XGT Series

User's Manual

XGF-RD4A/RD8A

XGF-RD4S



Safety Instructions

- Read this manual carefully before installing, wiring, operating, servicing or inspecting this equipment.
- Keep this manual within easy reach for quick reference.

LS ELECTRIC

Before using the product ...

For your safety and effective operation, please read the safety instructions thoroughly before using the product.

- ▶ Safety Instructions should always be observed in order to prevent accident or risk with the safe and proper use the product.
- ▶ Instructions are divided into “Warning” and “Caution”, and the meaning of the terms is as follows.



This symbol indicates the user is expected risk of death or serious injury in case of incorrect handling



This symbol indicates the user is expected risk of injury or property damage only in case of incorrect handling

Moreover, even classified events under its caution category may develop into serious accidents relying on situations. Therefore we strongly advise users to observe all precautions properly just like warnings.

- ▶ The marks displayed on the product and in the user’s manual have the following meanings.

 Be careful! Danger may be expected.

 Be careful! Electric shock may occur.

- ▶ The user’s manual even after read shall be kept available and accessible to any user of the product.

Safety Instructions for design process

Warning

- ▶ **Please install a protection circuit on the exterior of PLC so that the whole system may operate safely regardless of failures from external power or PLC.** Any abnormal output or operation from PLC may cause serious problems to safety in whole system.
 - Install protection units on the exterior of PLC like an interlock circuit that deals with opposite operations such as emergency stop, protection circuit, and forward/reverse rotation or install an interlock circuit that deals with high/low limit under its position controls.
 - If any system error (watch-dog timer error, module installation error, etc.) is detected during CPU operation in PLC, all output signals are designed to be turned off and stopped for safety. However, there are cases when output signals remain active due to device failures in Relay and TR which can't be detected. Thus, you are recommended to install an addition circuit to monitor the output status for those critical outputs which may cause significant problems.

- ▶ **Never overload more than rated current of output module nor allow to have a short circuit.** Over current for a long period time may cause a fire.

- ▶ **Never let the external power of the output circuit to be on earlier than PLC power,** which may cause accidents from abnormal output or operation.

- ▶ **Please install interlock circuits in the sequence program for safe operations in the system when exchange data with PLC or modify operation modes using a computer or other external equipments** Read specific instructions thoroughly when conducting control operations with PLC.

Safety Instructions for design process

Caution

- ▶ **I/O signal or communication line shall be wired at least 100mm away from a high-voltage cable or power line.** Fail to follow this instruction may cause malfunctions from noise

Safety Instructions on installation process

Caution

- ▶ **Use PLC only in the environment specified in PLC manual or general standard of data sheet.** If not, electric shock, fire, abnormal operation of the product may be caused.
- ▶ **Before install or remove the module, be sure PLC power is off.** If not, electric shock or damage on the product may be caused.
- ▶ **Be sure that every module is securely attached after adding a module or an extension connector.** If the product is installed loosely or incorrectly, abnormal operation, error or dropping may be caused. In addition, contact failures under poor cable installation will be causing malfunctions as well.
- ▶ **Be sure that screws get tighten securely under vibrating environments.** Fail to do so will put the product under direct vibrations which will cause electric shock, fire and abnormal operation.
- ▶ **Do not come in contact with conducting parts in each module,** which may cause electric shock, malfunctions or abnormal operation.

Safety Instructions for wiring process

Warning

- ▶ **Prior to wiring works, make sure that every power is turned off.** If not, electric shock or damage on the product may be caused.
- ▶ **After wiring process is done, make sure that terminal covers are installed properly before its use.** Fail to install the cover may cause electric shocks.

Caution

- ▶ **Check rated voltages and terminal arrangements in each product prior to its wiring process.** Applying incorrect voltages other than rated voltages and misarrangement among terminals may cause fire or malfunctions.
- ▶ **Secure terminal screws tightly applying with specified torque.** If the screws get loose, short circuit, fire or abnormal operation may be caused. Securing screws too tightly will cause damages to the module or malfunctions, short circuit, and dropping.
- *
 - ▶ **Be sure to earth to the ground using Class 3 wires for PE terminals which is exclusively used for PLC.** If the terminals not grounded correctly, abnormal operation or electric shock may be caused.
 - ▶ **Don't let any foreign materials such as wiring waste inside the module while wiring,** which may cause fire, damage on the product or abnormal operation.
 - ▶ **Make sure that pressed terminals get tighten following the specified torque. External connector type shall be pressed or soldered using proper equipments.**

Safety Instructions for test-operation and maintenance

Warning

- ▶ **Don't touch the terminal when powered.** Electric shock or abnormal operation may occur.
- ▶ **Prior to cleaning or tightening the terminal screws, let all the external power off including PLC power.** If not, electric shock or abnormal operation may occur.
- ▶ **Don't let the battery recharged, disassembled, heated, short or soldered.** Heat, explosion or ignition may cause injuries or fire.

Caution

- ▶ **Do not make modifications or disassemble each module.** Fire, electric shock or abnormal operation may occur.
- ▶ **Prior to installing or disassembling the module, let all the external power off including PLC power.** If not, electric shock or abnormal operation may occur.
- ▶ **Keep any wireless equipment such as walkie-talkie or cell phones at least 30cm away from PLC.** If not, abnormal operation may be caused.
- ▶ **When making a modification on programs or using run to modify functions under PLC operations, read and comprehend all contents in the manual fully.** Mismanagement will cause damages to products and accidents.
- ▶ **Avoid any physical impact to the battery and prevent it from dropping as well.** Damages to battery may cause leakage from its fluid. When battery was dropped or exposed under strong impact, never reuse the battery again. Moreover skilled workers are needed when exchanging batteries.

Safety Instructions for waste disposal

 **Caution**

- ▶ **Product or battery waste shall be processed as industrial waste.** The waste may discharge toxic materials or explode itself.

Revision History

Version	Date	Remark	Revised position
V 1.0	2006.5	1. First Edition	-
V1.1	2009.6	1. Added XGF-RD4S 2. Added XGI/XGR CPU	7-1~7-21 8-1~6
V1.2	2011.05	1. Updated the 3-wiree sensor wiring method	Ch.3
V1.3	2013.11	1. Added XGF-RD8A	
V1.4	2015.7	1. Domain address and CI changed 2. General specifications changed by reason of changed IEC specifications	2-1
V1.8	2020.7	1. Format and contents modification according to the change of company name(LSIS → LS ELECTRIC)	

Thank you for purchasing PLC of LS ELECTRIC Co., Ltd.

Before use, make sure to carefully read and understand the User's Manual about the functions, performances, installation and programming of the product you purchased in order for correct use and importantly, let the end user and maintenance administrator to be provided with the User's Manual.

The User's Manual describes the product. If necessary, you may refer to the following description and order accordingly. In addition, you may connect our website (<http://www.lselectric.co.kr/>) and download the information as a PDF file.

Relevant User's Manuals

Title	Description
XG5000 User's Manual (for XGK, XGB)	XG5000 software user manual describing online function such as programming, print, monitoring, debugging by using XGK, XGB CPU
XG5000 User's Manual (for XGI, XGR)	XG5000 software user manual describing online function such as programming, print, monitoring, debugging by using XGI, XGR CPU
XGK/XGB Instructions & Programming User's Manual	User's manual for programming to explain how to use instructions that are used PLC system with XGK, XGB CPU.
XGI/XGR/XEC Instructions & Programming User's Manual	User's manual for programming to explain how to use instructions that are used PLC system with XGI, XGR, XEC CPU.
XGK CPU User's Manual (XGK-CPUA/CPUE/CPUH/CPUS/CPUU)	XGK-CPUA/CPUE/CPUH/CPUS/CPUU user manual describing about XGK CPU module, power module, base, IO module, specification of extension cable and system configuration, EMC standard
XGI CPU User's Manual (XGI-CPUU/CPUH/CPUS)	XGI-CPUU/CPUH/CPUS user manual describing about XGI CPU module, power module, base, IO module, specification of extension cable and system configuration, EMC standard
XGR redundant series User's Manual	XGR- CPUH/F, CPUH/T user manual describing about XGR CPU module, power module, extension drive, base, IO module, specification of extension cable and system configuration, EMC standard

The User's Manual is based on XGF-RD4A/RD8A/RD4S.

This manual is based on the following versions.

Product name	OS version
XGK-CPUH, CPUS, CPUA, CPUE, CPUU	V3.0
XGI-CPUU, CPUH, CPUS	V2.1
XGR-CPUH/F, CPUH/T	V1.3
XG5000	V3.63

◎ Table of Content ◎

Chapter 1 Introduction..... 1-1~1-2

1.1 Features.....	1-1
1.2 Terminology.....	1-2

Chapter 2 Specification 2-1~2-19

2.1 General Specifications	2-1
2.2 Performance Specifications	2-2
2.3 Part Names and Functions	2-3
2.4 Characteristics of RTD Input Module	2-4
2.4.1 Temperature conversion	2-4
2.4.2 Conversion speed.....	2-6
2.4.3 Accuracy.....	2-6
2.4.4 Temperature conversion.....	2-6
2.4.5 Scaling function	2-7
2.4.6 Disconnection detecting function	2-8
2.4.7 Sensor connection.....	2-10
2.5 Functions of RTD Input Module	2-13
2.5.1 Averaging function.....	2-13
2.5.2 Filtering function	2-15
2.5.3 Alarming function.....	2-16
2.5.4 Max/Min displaying function	2-17

Chapter 3 Installation and Wiring 3-1~3-5

3.1 Installation	3-1
3.1.1 Installation ambience	3-1
3.1.2 Handling precautions.....	3-1
3.2 Wiring.....	3-2
3.2.1 Wiring precautions	3-2

3.2.2 Wiring examples	3-2
-----------------------------	-----

Chapter 4 Operation Setting and Monitoring.....	4-1~4-39
--	-----------------

4.1 Operation Procedure	4-1
4.2 Operation Parameters Setting	4-2
4.2.1 Setting items.....	4-2
4.2.2 How to use [I/O parameters]	4-3
4.3 Functions of Special Module Monitoring.....	4-9
4.4 Precautions.....	4-10
4.5 Special Module Monitoring.....	4-11
4.5.1 Run [Special Module Monitoring]	4-11
4.5.2 How to use [Special Module Monitoring]	4-11
4.6 Automatic Registration of U Device	4-16
4.6.1 Automatic registration of U device.....	4-16
4.6.2 Save variables.....	4-18
4.6.3 View variables in the program	4-18

Chapter 5 Internal Memory Configuration and Function(For XGK).....	5-1~5-60
---	-----------------

5.1 Internal Memory Configuration	5-1
5.1.1 Input/Output area of conversion data	5-1
5.1.2 Operation parameter setting area (PUT/PUTP)	5-4
5.1.3 The other data monitoring area (GET/GETP).....	5-6
5.2 Internal Memory Functions	5-7
5.2.1 Module READY/ERRPR flag.....	5-7
5.2.2 Run channel flag.....	5-7
5.2.3 Flag to output process alarm	5-8
5.2.4 Flag to output input variation alarm.....	5-8
5.2.5 Temperature-converted value	5-8
5.2.6 Scaled calculation value.....	5-9
5.2.7 Max/Min temperature-converted value output	5-9
5.2.8 Data uploading time.....	5-10
5.2.9 Command contact information.....	5-10
5.3 Operation Parameters Setting Area.....	5-11

5.3.1 Channel Enable/Disable 5-11

5.3.2 Sensor type setting 5-12

5.3.3 Temperature conversion unit..... 5-13

5.3.4 Filter value 5-14

5.3.5 Averaging method 5-15

5.3.6 Averaging value 5-16

5.3.7 Scaling type 5-17

5.3.8 Scaling range..... 5-18

5.3.9 Process limit..... 5-19

5.3.10 Process alarm hysteresis 5-20

5.3.11 Input variation alarm type 5-21

5.3.12 Input variation alarm Max./Min. value..... 5-22

5.3.13 Detection cycle of input variation alarm..... 5-23

5.3.14 Setting error information..... 5-24

5.3.15 Input variation value/rate output..... 5-25

5.3.16 Sensor disconnection information 5-26

Chapter 6 Programming(For XGK) 6-1~6-12

6.1 Read/Write of Operation Parameters Setting Area..... 6-1

 6.1.1 Read of operation parameters setting area (GET, GETP command) 6-1

 6.1.2 Write of operation parameters setting area (PUT, PUTP command) 6-2

6.2 Basic Program 6-3

 6.2.1 Program example through [I/O parameters] setting 6-3

 6.2.2 Program example using PUT/GET command 6-4

6.3 Application Program..... 6-5

 6.3.1 Monitoring program of °C temperature-converted and scaled value 6-5

 6.3.2 Program with °F temperature-converted value and highest/lowest process alarm 6-9

Chapter 7 Global Variable Configuration and Function(For XGI/XGR) 7-1~7-21

7.1 Global variable (Data area)..... 7-1

 7.1.1 Conversion data I/O area 7-1

 7.1.2 How to use Global variable 7-4

7.2 Area using PUT/GET Function Block (Parameter Area)	7-11
7.2.1 Area using PUT/GET Function Block (Parameter Area)	7-11
7.2.2 Other data monitor area (Using GET/GETP)	7-13
7.2.3 PUT/GET instruction	7-14
7.2.4 Example of PUT/GET instruction	7-16

Chapter 8 Programming (For XGI/XGR) 8-1~8-14

8.1 Basic Program	8-1
8.1.1 Program example using [I/O parameter]	8-1
8.1.2 Program example using PUT/GET instruction	8-3
8.2 Application Program	8-4
8.2.1 Program monitoring Celsius conversion value and scaling operation value	8-4

Chapter 9 Troubleshooting 9-1~9-4

9.1 Error Code	9-1
9.2 Troubleshooting Procedure	9-2
9.2.1 RUN LED flickering	9-2
9.2.2 RUN LED off	9-2
9.2.3 CPU cannot read temperature conversion value.	9-3
9.2.4 RTD input value and the detected value is not consistent	9-3
9.2.5 RTD module hardware error	9-4
9.2.6 RTD module status check through XG5000 system monitoring	9-4

Appendix 1 Standard Resistance Value A1-1~A1-2

Appendix 2 Dimension A2-1~A2-3

Appendix 3 User Offset and Gain Setting Function..... A3-1~A3-31

Warranty and Environmental Policy

Chapter 1 Introduction

This user manual is prepared to describe specifications, handling and programming methods for XGF-RD4A, XGF-RD8A, XGF-RD4S type Resistance Temperature Detector (RTD) module used in association with CPU module of XGT PLC series.

The RTD input module converts the input temperature data measured by platinum RTD sensor, PT100 or JPT100, to signed 16-bit binary data so to output applicable digital value.

(XGF-RD4S module is available for an additional PT1000 and NI100 sensor type)

1.1 Features

- 1) Selection of module applicable for purpose
No insulation between channels(XGF-RD4A,XGF-RD8A),
insulation between channels (XGF-RD4S)
- 2) 4 types of RTD sensor are available.
PT100, JPT100
PT1000, NI100 (applicable to XGF-RD4S)
- 3) Disconnection detection
Detects and displays disconnection of RTD sensor wire or extended lead wire and RTD module.
Especially, a function to display disconnection status for each wire and channel is available.
- 4) Temperature can be converted to numeric value to the first decimal point.
Temperature can be converted to the Celsius or Fahrenheit scale temperature value as desired.
- 5) Temperature-converted input value can be scaled to specified 16-bit binary data.
Temperature-converted value can be output after scaled within the range of -32768~32767 /
0~65535.
- 6) Various supplementary functions
Filtering, averaging (time/frequency/movement), alarming (for process/inputting change),
max/min detection, etc.
User offset/gain adjust function (applicable to XGF-RD4S)
- 7) Easy setting parameters and monitoring data by means of GUI (Graphical User Interface)
Setting parameters which was specified by commands can be available by [I/O parameter setting]
of which user interface is reinforced for convenience of the user. The sequence programming can
be lightened with [I/O parameter setting]. In addition, temperature-converted value can be
monitored with easy through [Special module monitor] function.

1.2. Terminology

1.2.1 Analog quantity – A

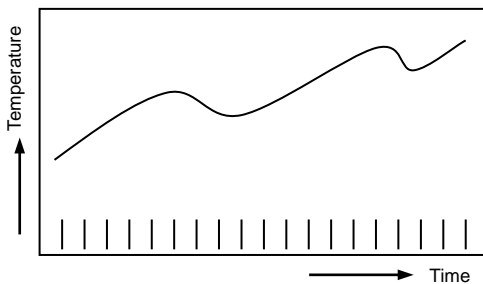

[Fig. 1.1] Analog Quantity

Continuous changeable value such as voltage, current, temperature, velocity, pressure and flow is called analog value. For example, temperature changes continuously with time as shown in Fig. 1.1. PLC can convert continuous changeable temperature to digital value with RTD input module.

1.2.2 Digital quantity - D

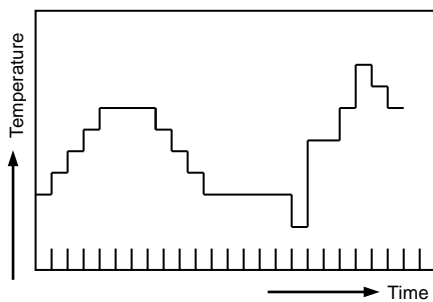

[Fig. 1.2] Digital Quantity

In Fig.1.2, A non-continuous changeable value, for example number of man can be counted as 0, 1, 2, 3... is called a digital value. On and Off signals are displayed as digital value 0 and 1, respectively.

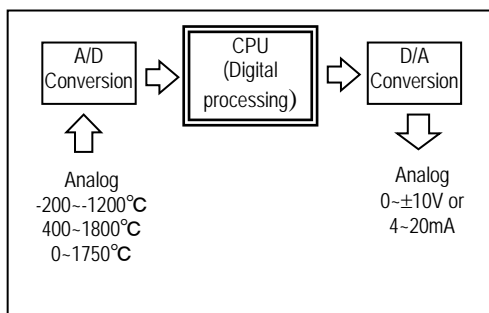

[Fig 1.3] Processing in the PLC

Analog value cannot be directly input to the CPU module for digital processing. Therefore, analog value should be converted to a digital value to be input to the CPU module. In addition, for external output of analog value, digital value of the CPU module should be converted into analog value.

1.2.3. Platinum Resistance Thermometer Device

This is a sensor that detects temperature by detection the change of resistance based on the change of temperature.

The Pt 100/JPt 100 outputs the resistance value of 100.00 Ω at the temperature of 0 °C

1.2.4. Disconnection detecting function

If a part of the connected RTD or cable is disconnected, the out-of-range voltage is input by the internal disconnection detecting circuit and the connection or disconnection is detected.

Chapter 2 Specification

2.1 General Specifications

General specifications of XGT series are as shown in Table 2.1.

No.	Items	Specification	Reference					
1	Ambient Temp.	0 ~ 55 °C						
2	Storage Temp.	-25 ~ +70 °C						
3	Ambient humidity	5 ~ 95%RH (Non-condensing)						
4	Storage humidity	5 ~ 95%RH (Non-condensing)						
5	Vibration	Occasional vibration			-	IEC61131-2		
		Frequency	Acceleration	Pulse width	Times			
		$5 \leq f < 8.4\text{Hz}$	-	3.5mm	10 times each direction (X,Y and Z)			
		$8.4 \leq f \leq 150\text{Hz}$	9.8m/s ² (1G)	-				
		Continuous vibration						
		Frequency	Acceleration	Pulse width				
		$5 \leq f < 8.4\text{Hz}$	-	1.75mm				
$8.4 \leq f \leq 150\text{Hz}$	4.9m/s ² (0.5G)	-						
6	Shocks	<ul style="list-style-type: none"> • Peak acceleration : 147 m/s²(15G) • Duration : 11ms • Pulse wave type : Half-sine (3 times each direction per each axis) 	IEC61131-2					
7	Impulse noise	Square wave impulse noise	AC: ±1,500 V DC: ±900 V	LS ELECTRIC stadard				
		Electrostatic discharge	Voltage: 4kV (Contact discharge)	IEC61131-2 IEC61000-4-2				
		Radiated electromagnetic field noise	80 ~ 1000 MHz, 10V/m	IEC61131-2, IEC61000-4-3				
		Fast transient /Burst noise	<table border="1"> <tr> <td>Classification</td> <td>Power supply</td> <td>Digital/Analog Input/Output, Communication Interface</td> </tr> <tr> <td>Voltage</td> <td>2kV</td> <td>1kV</td> </tr> </table>	Classification	Power supply	Digital/Analog Input/Output, Communication Interface	Voltage	2kV
Classification	Power supply	Digital/Analog Input/Output, Communication Interface						
Voltage	2kV	1kV						
8	Operation mbience	Free from corrosive gases and excessive dust						
9	Altitude	Less than 2,000m						
10	Pollution degree	Less than 2						
11	Cooling method	Air-cooling						

[Table 2.1] General Specifications

Notes

1) IEC (International Electromechanical Commission)

: An international civil community that promotes international cooperation for standardization of electric/ electro technology, publishes international standard and operates suitability assessment system related to the above.

2) Pollution Degree

: An index to indicate the pollution degree of used environment that determines the insulation performance of the device. For example, pollution degree 2 means the state to occur the pollution of non-electric conductivity generally, but the state to occur temporary electric conduction according to the formation of dew.

2.2. Performance Specifications

Table. 2.2 shows performance specifications of the RTD module.

[Table 2.2] Performance Specifications

Item		XGF-RD4A	XGF-RD8A	XGF-RD4S		
No. of input channel		4channels	8channels	4channels		
Input sensor type	PT100	JIS C1604-1997				
	PT1000	-		JIS C1604-1997		
	JPT100	JIS C1604-1981 , KS C1603-1991				
	NI100	-		DIN 43760-1987		
Input temp. range	PT100	-200 ~ 850℃				
	PT1000	-200 ~ 640℃				
	JPT100	-		-200 ~ 850℃		
	NI100	-		-60 ~ 180℃		
Digital output	Temp. indication (0. unit)	PT100	-2000 ~ 8500	PT100	-2000 ~ 8500	
				PT1000	-2000 ~ 8500	
		JPT100	-2000 ~ 6400	JPT100	-2000 ~ 6400	
				NI100	-600~1800	
	Scaling indication (User range setting)	0 ~ 65535 -32768 ~ 32767				
Precision	Normal temp. (25℃)	Within ±0.2%		Within ±0.1%		
	All range (0~55℃)	Within ±0.3%		Temp. coefficient ±70 ppm/℃ (0.007%/℃)		
Conversion speed		40ms / channel				
Insulation method	Between channels	No insulation		Insulation		
	Terminal – PLC power	Insulation (Photo-Coupler)				
Terminal block		18 points terminal	24 points terminal	18 points terminal		
I/O occupation point		Fixed type:64, Flexible type:16				
Temp. measure wiring method		3 lines		3,4lines		
Function	Average function	Time average (320 ~ 64000ms)	Time average (640 ~ 64000ms)	Digital filter (160 ~ 64000ms)		
		Count average (2 ~ 64000 times)				
		Moving average (2 ~ 100 times)				
	Filter function	Digital filter (160 ~ 64000ms)	Digital filter (320 ~ 64000ms)	Digital filter (160 ~ 64000ms)		
		Process alarm (Max. upper limit HH , upper limit H , lower limit L , Max. lower limit LL)				
	Alarm function	Input change rate (Rate alarm)				
		Disconnection detection				
		Indication				
Max./Min. indication	Indication					
User offset/gain setting	-	Enable	-			
Consumption current		450mA	780mA	783mA		
Weight		140g	113g	150g		

2.3 Part Names and Functions

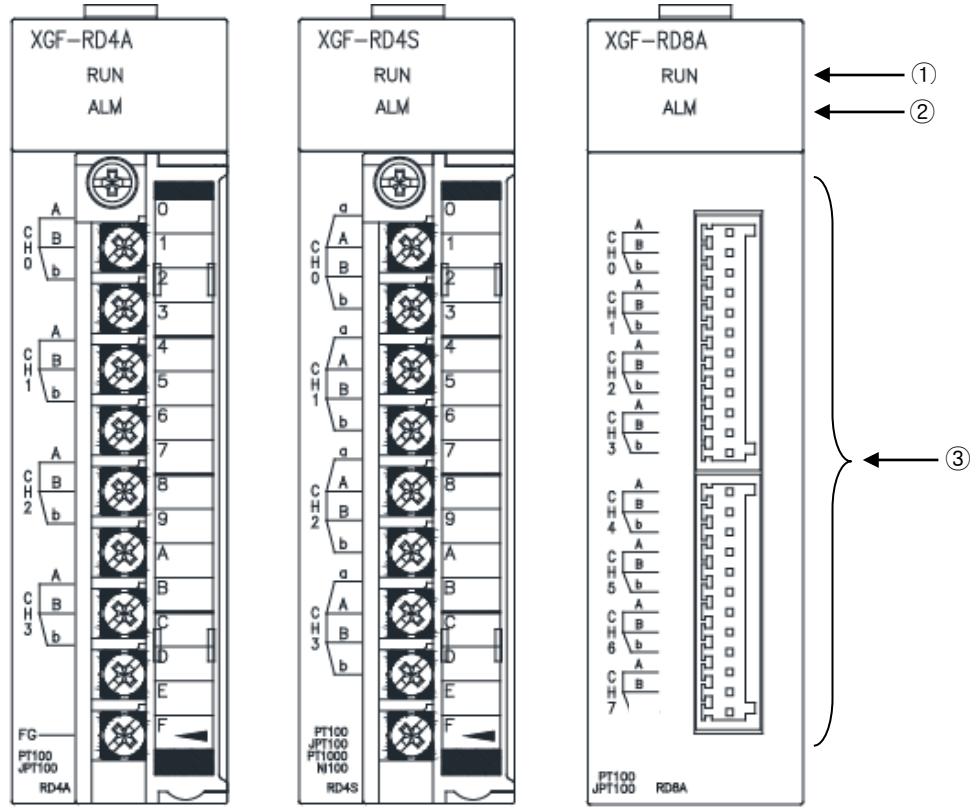

No.	Descriptions
①	RUN LED ▶ Displays the hardware operation status (Fatal fault) On: module H/W Normal Flickering: module H/W Error (0.2s flickering) Off: H/W abnormal
②	ALM LED ▶ Displays the status of the channels(Soft fault) On: Normal status Flickering: Disconnection is detected (1sec flickering) Off: Operation stop of all channels
③	Terminal block ▶ XGF-RD4A, XGF-RD8A, XGF-RD4S module can connected with RTD temperature sensor. 3 line/4 line RTD wiring

Notes

- 1) When using XGR system
 - In XGR system, RTD module can be equipped at only extension base.
- 2) XGF-RD4A, XGF-RD8A module can connected with 3-wired, XGF-RD4S module can connected with 3-wired or 4-wired RTD sensor.
 - If you use other RTD sensor, temperature variation can occur.

2.4 Characteristics of RTD Input Module

2.4.1 Temperature conversion

Since RTD sensor has non-linear characteristic, RTD input module linearizes the relationship between input and out in each section in order to reduce temperature conversion error caused by the nonlinearity.

4 types of RTD sensor's temperature characteristic with resistance is as follows:

1) PT100: JIS1064-1997

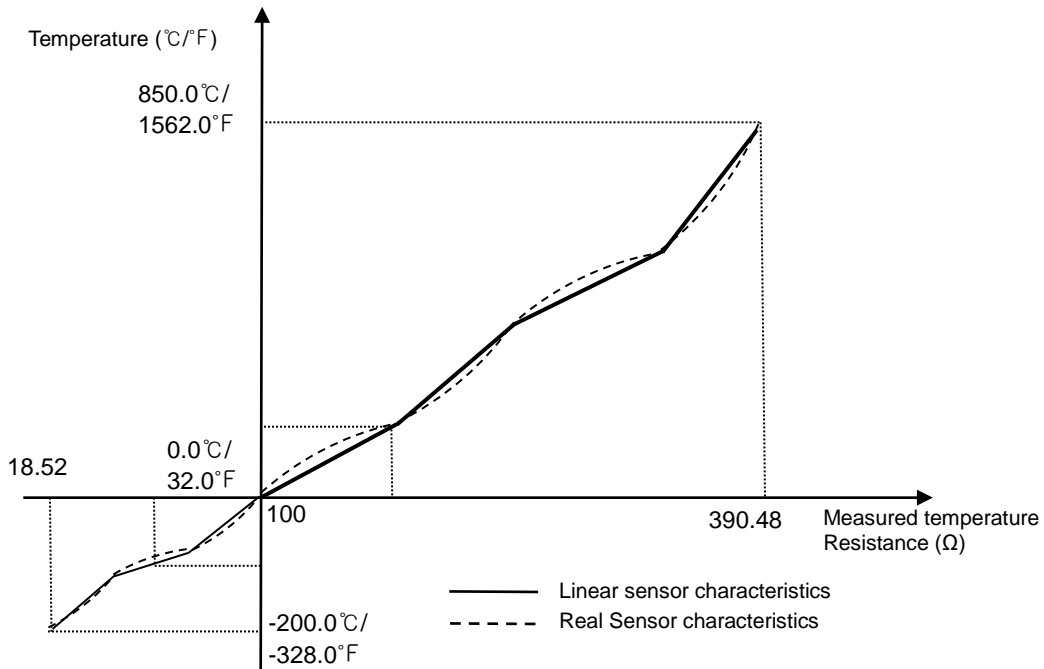

2) JPT100: JIS C1604-1981, KS C1603-1991

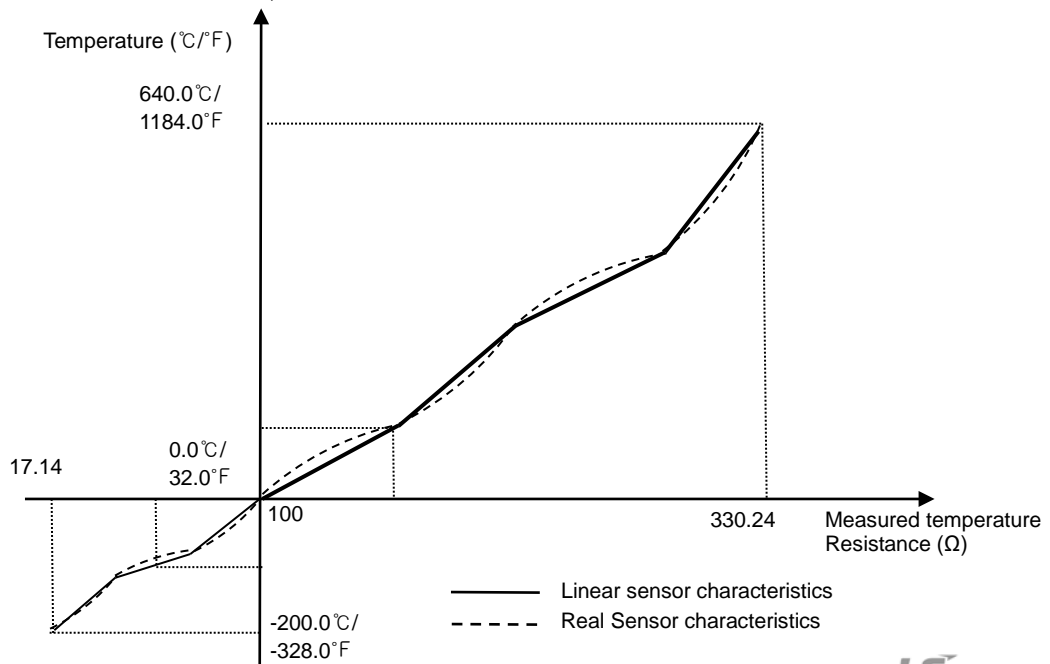

3) PT1000: JIS1064-1997

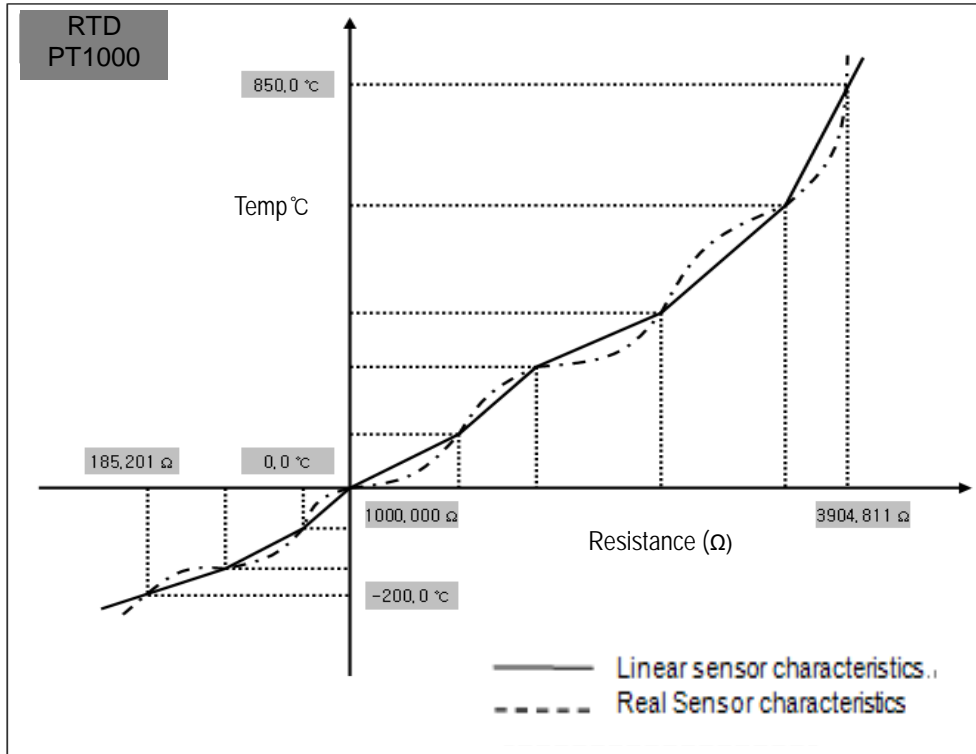

4) NI100: DIN 43760-1987

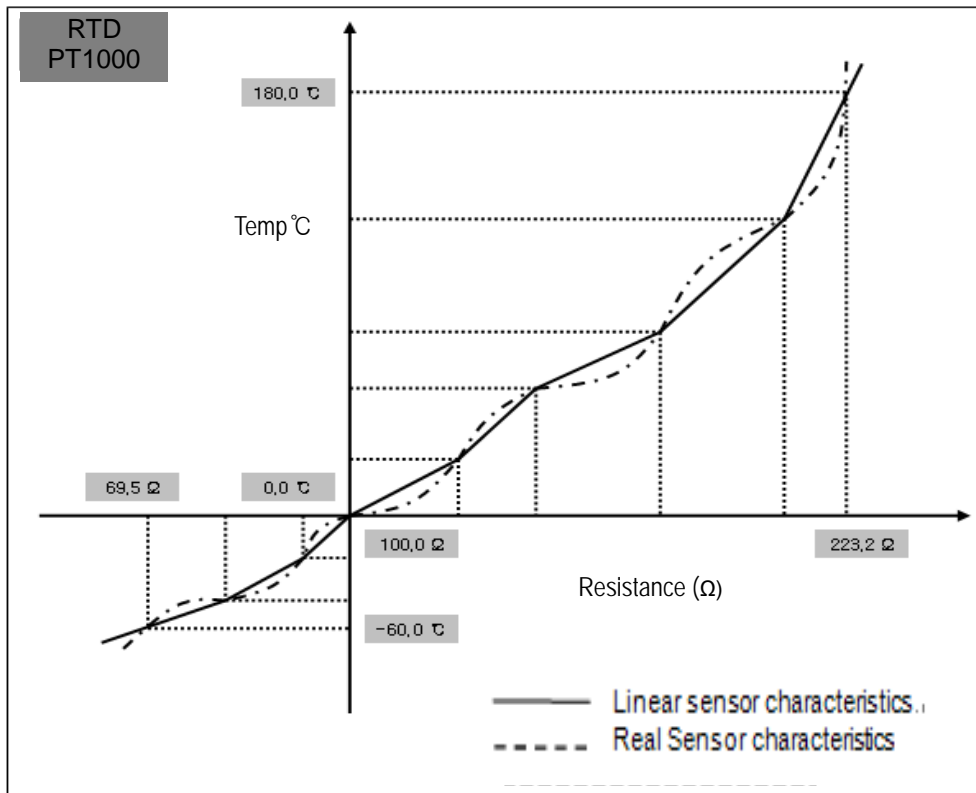

2.4.2 Conversion speed

Conversion speed of the XGF-RD4A/RD8A/RD4S modules are 40 ms per channel and each channel is converted sequentially, that is, one channel is converted and then the next channel is converted. (Run/stop can be specified independently for each channel.)
The conversion speed includes the time to convert input temperature (resistance value) to digital value and to save the converted digital data into the internal memory.

∴ Processing time = 40ms X Number of the using channels

[Example] 3 channels are used: Processing time = 40ms X 3 = 120ms

2.4.3 Accuracy

The accuracy of RTD module is described below.

1) XGF-RD4A/ XGF-RD8A

- When the ambient temperature is $25 \pm 5^{\circ}\text{C}$: within $\pm 0.2\%$ of available input range
- When the ambient temperature is 0 to 55°C : within $\pm 0.3\%$ of available input range

2) XGF-RD4S

- When the ambient temperature is $25 \pm 5^{\circ}\text{C}$: within $\pm 0.1\%$ of available input range
- When the ambient temperature is 0 to 55°C : $\pm 70 \text{ ppm}/^{\circ}\text{C}$ ($0.007\%/^{\circ}\text{C}$)

Example) PT100 in XGF-RD4A is used and the ambient temperature is normal.

To measure 100°C , the conversion data output range:

$$100^{\circ}\text{C} - [\{ 850 - (-200) \} \times 0.2 \%] \sim 100^{\circ}\text{C} + [\{ 850 - (-200) \} \times 0.2 \%] = 97.9 \sim 102.1 [^{\circ}\text{C}]$$

2.4.4 Temperature conversion

1) The input temperature is converted to digital value to the first decimal place.

Ex.) If the detected temperature is 123.4°C , its converted value to be saved to the internal memory will be 1234.

2) Temperature can be converted to Celsius or Fahrenheit scale temperature value as desired.

Ex.) If Pt100 sensor is used, the temperature of 100.0°C can be converted to 2120 when Fahrenheit scale is used.

- Conversion $^{\circ}\text{C}$ to $^{\circ}\text{F}$, $F = \frac{9}{5}C + 32$

- Conversion $^{\circ}\text{F}$ to $^{\circ}\text{C}$, $C = \frac{5}{9}(F - 32)$

3) Maximum temperature input range is higher/lower within 10°C than regular temperature input range. However, the precision will not be guaranteed for any temperature out of regular temperature input range.

Maximum temperature input ranges of sensor are as follows;

- PT100 : $-200.0 \sim 850.0^{\circ}\text{C}$
- JPT100 : $-200.0 \sim 640.0^{\circ}\text{C}$
- PT1000 : $-200.0 \sim 850.0^{\circ}\text{C}$
- NI100 : $-60.0 \sim 180.0^{\circ}\text{C}$

2.4.5 Scaling function

It is used to scale and output the range specified by the user other than temperature range. Setting ranges available are signed 16-bit data type of -32768~32767 and unsigned 16-bit data type of 0~65535. If user selects one of these two selections to specify the range, the input temperature will be stored in the internal memory with scaled value.

Ex.) If scaling is set to -100 ~ 1100 as signed with 200°C input by Pt100, the scaled value will be as follows;

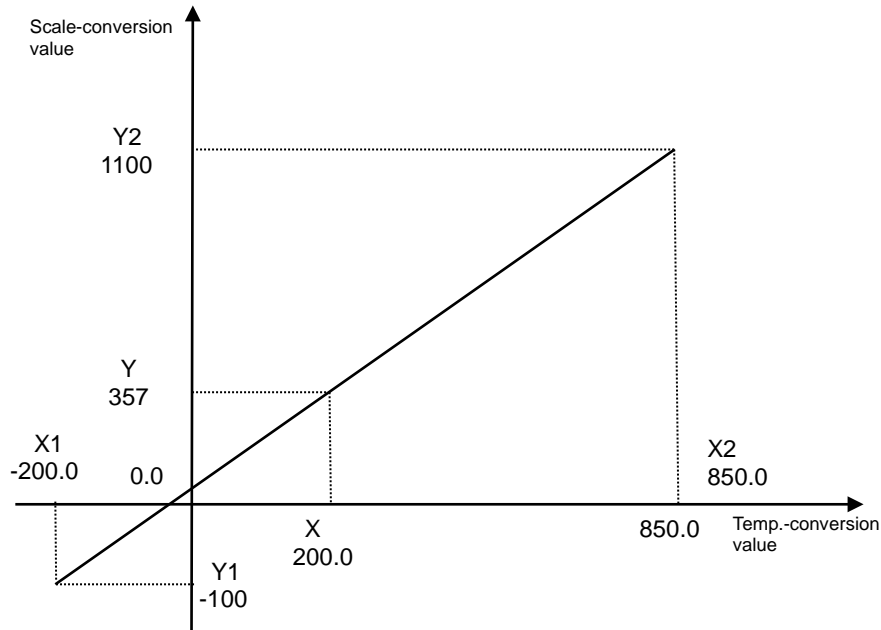

- Scale calculation: $Y = \frac{Y_2 - Y_1}{X_2 - X_1} (X - X_1) + Y_1$
- PT100: X= -200.0, X2= 850.0
- JPT100: X1= -200.0, X2= 640.0
- PT1000: X= -200.0, X2= 850.0
- NI100: X= -60.0, X2= 180.0 in the applicable formula.

Notes

- 1) Non-linear characteristics: The resistance-temperature characteristics for RTD sensor are presented with table (JIS C1604-1997). This characteristics table displays resistance value of the sensor to temperature, namely, the change of the resistance value per increment of 1°C. When the temperature is changed by 1°C, the change of resistance is not in constant width but in different width per section, which is called the non-linear characteristics.
- 2) When consigned, the module is adjusted Offset/Gain of each channel with standard resistance source. For accuracy of the module, this value is prohibited for user to change.

2.4.6 Disconnection detecting function

- 1) As a module used to measure the temperature with the RTD temperature sensor directly connected, it detects and displays disconnection of the sensor connected. If any disconnection occurs in the sensor used and extended lead wire, LED (ALM) will flicker in a cycle of 1 second and produce an error code.
- 2) Disconnection can be detected per channel, however, only for the channel specified to run. LED (ALM) is used in common for all the channels. It will flicker if one or more channels are disconnected.
- 3) The figure below shows the temperature sensor's appearance of the 3-wired RTD. (The appearance depends on its purpose.)

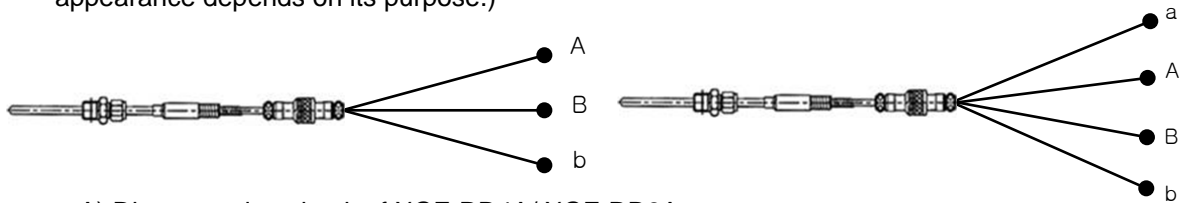

A) Disconnection check of XGF-RD4A/ XGF-RD8A

* A disconnection: if disconnected between terminal A and terminal board of the module in the sensor figure.

* B disconnection: if disconnected between terminal B (two for 3-wired sensor) and terminal board of the module in the sensor figure, or if A and B lines are all disconnected.

B) Disconnection check of XGF-RD4S

When one, two, three and four of the lines (a, A, B, b) are disconnected in the figure.

- 4) This basic connection between XGF-RD4A/XGF-RD8A and RTD Sensor is based on 3-wired RTD sensor. If 2-wired or 4-wired sensor is used, the connection between the sensor and the module shall be kept as 3-wired. Disconnection will be detected on the basis of 3-wired wiring.
This basic connection between XGF-RD4S and RTD Sensor is based on 4-wired RTD sensor. If 2-wired or 3-wired sensor is used, the connection between the sensor and the module shall be kept as 4-wired. Disconnection will be detected on the basis of 4-wired wiring.

A) XGF-RD4A/RD8A

Connection status	Channel setting status	LED status (Disconnection Flag ON/Off)	Temperature of disconnection status
Normal	Specified	Off (Disconnection Flag Off)	-
	Not specified	Off (Disconnection Flag Off)	-
A line disconnected	Specified	Flickering (Disconnection Flag ON)	Maximum value
	Not specified	Off (Disconnection Flag Off)	-
B line disconnected	Specified	Flickering (Disconnection Flag ON)	Minimum value
	Not specified	Off (Disconnection Flag Off)	-
Sensor not connected	Specified	Flickering (Disconnection Flag ON)	Minimum value
	Not specified	Off (Disconnection Flag Off)	-

B) XGF-RD4S

Connection status	Channel setting status	LED status (Disconnection Flag ON/Off)	Temperature of disconnection status
Normal	Specified	Off (Disconnection Flag Off)	-
	Not specified	Off (Disconnection Flag Off)	-
A, B line disconnected	Specified	Flickering (Disconnection Flag ON)	Minimum value
	Not specified	Off (Disconnection Flag Off)	-
Sensor not connected	Specified	Flickering (Disconnection Flag ON)	Minimum value
	Not specified	Off (Disconnection Flag Off)	-

2.4.7 Sensor connection

- 3 types of sensor-connecting methods are available (2, 3 and 4-wired).
- The standard wiring method for XGF-RD4A/ XGF-RD8A module is 3-wired wiring, and XGF-RD4S module is 3-wired wiring or 4-wired wiring.
- Use an identical type of wire (thickness, length, etc.) for each 3 wire when extended lead wire is used.
- The resistance of each conductor is to be less than 10Ω . (If larger than this, it will cause an error.)
- Resistance difference of each conductor is to be less than 1Ω . (If larger than this, it will cause an error.)
- Length of wire is to be as short as possible and it is recommended to connect the wire directly to the terminal block of XGF-RD4A without connection terminal unit. If a connection terminal is to be used, compensating wire shall be connected as shown below.

A) Sensor connection of XGF-RD4A/ XGF-RD8A

- 1) If 2-wired sensor is used (connection terminal unit is used)

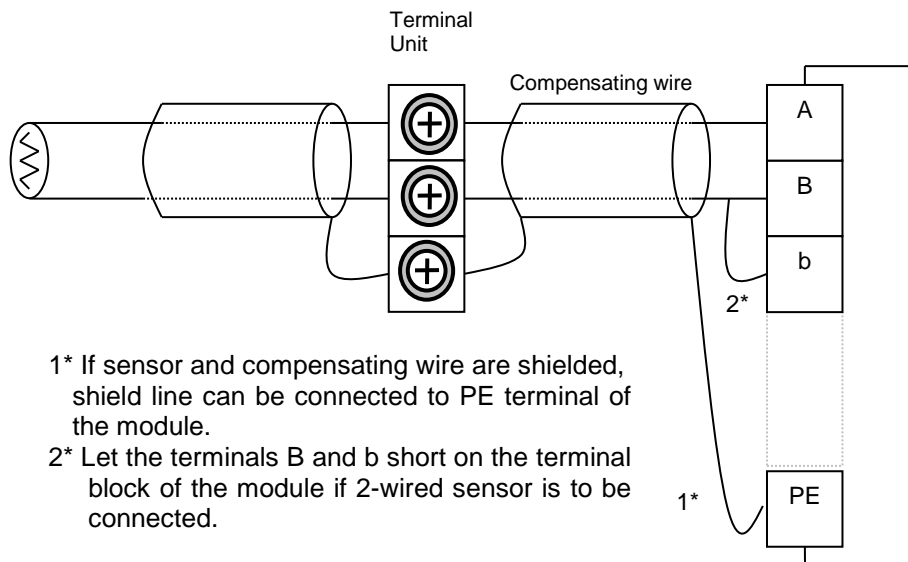

- 2) If 3-wired sensor is used (connection terminal unit is used)

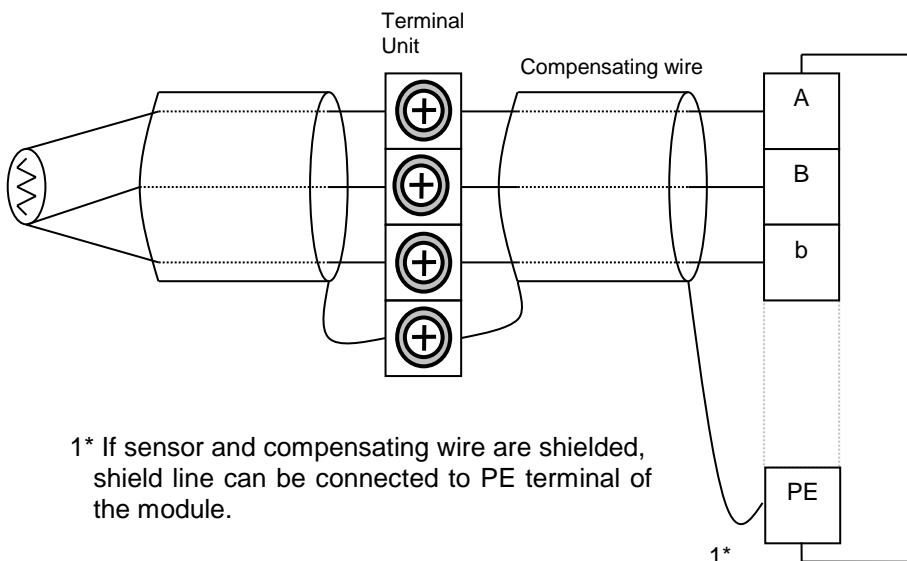

3) If 4-wired sensor is used (connection terminal unit is used)

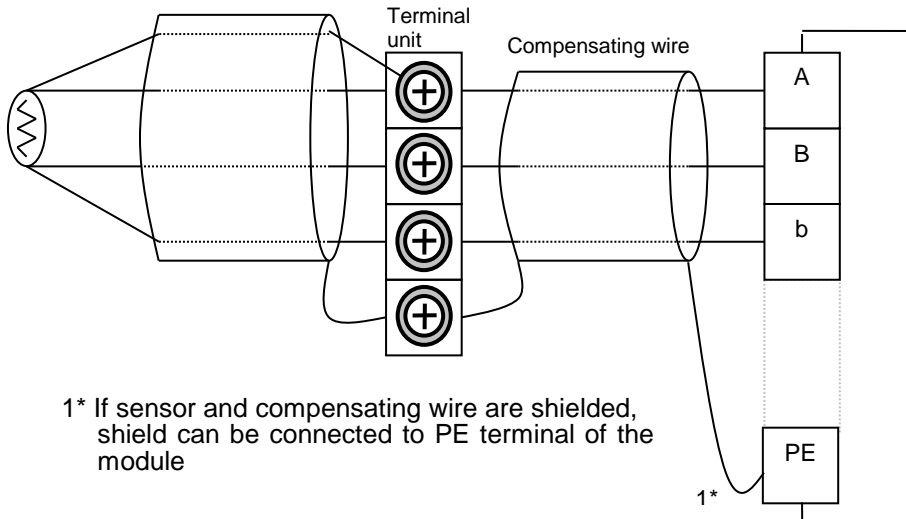

B) Sensor connection of XGF-RD4S

1) If 2-wired sensor is used (connection terminal unit is used)

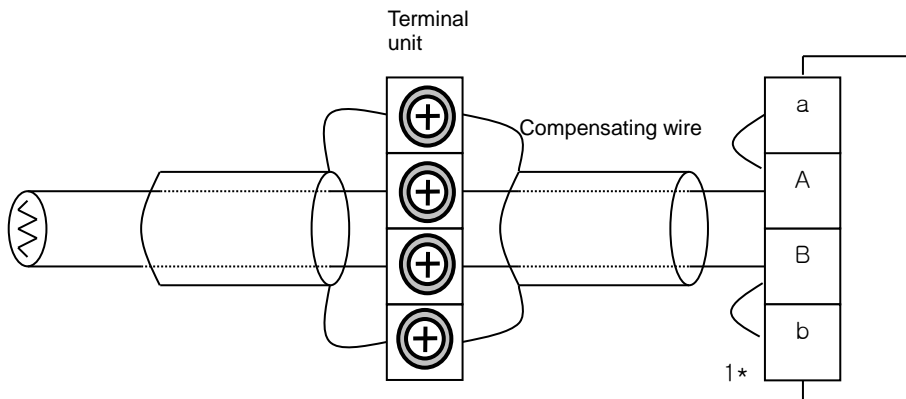

1* Let the terminals A and a, B and b short on the terminal block of the module if 2-wired sensor is to be connected.

- The standard wiring method for XGF-RD4S module is 3-wired or 4-wired wiring. If 2-wired RTD sensor is used to XGF-RD4S module, must be maintained in the form of a 4-wired wiring, in the case an error may occur in accuracy.

2) If 3-wired sensor is used (connection terminal unit is used)

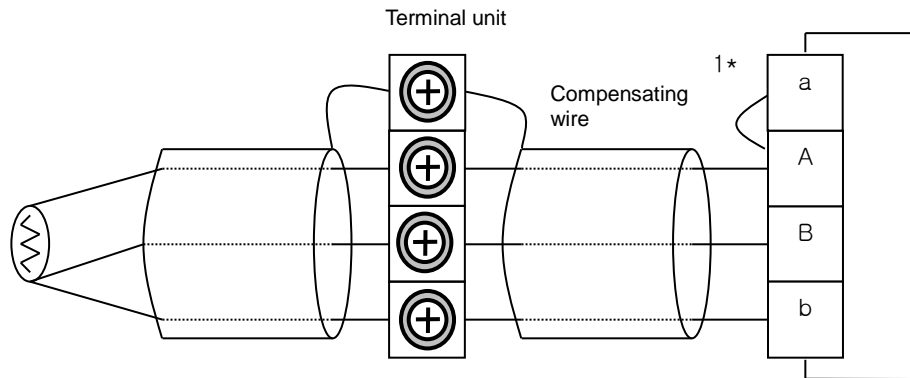

1* Let the terminals A and a short on the terminal block of the module if 3-wired sensor is to be connected

- Select the sensor type of I/O parameter to 3-wired sensor type.

3) If 4-wired sensor is used (connection terminal unit is used)

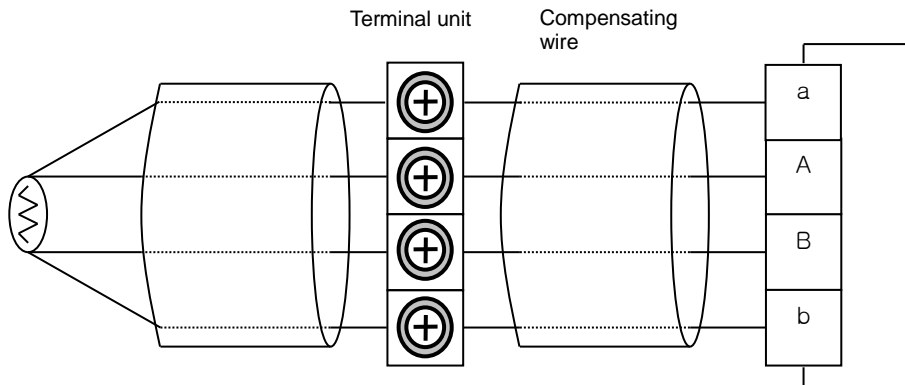

- Select the sensor type of I/O parameter to 4-wired sensor type.

2.5 Functions of RTD Input Module

2.5.1 Averaging function

1) Time average

It is used to accumulate the temperature-conversion value of the specified channel for a specific time and output the average of the sum in digital data.

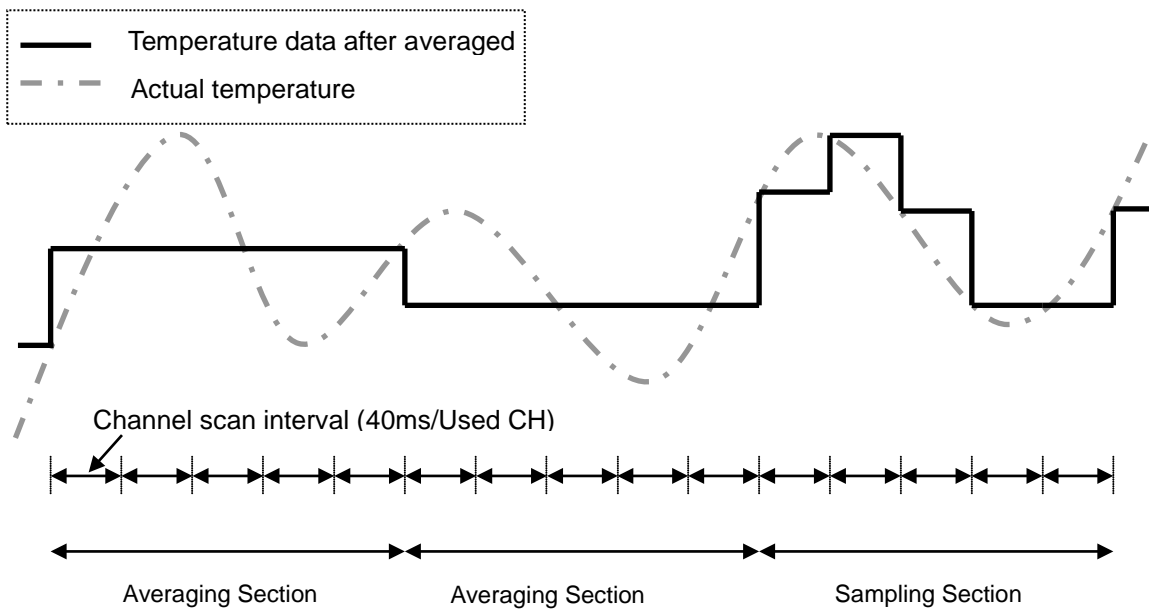

- Average time setting range
 - XGF-RD4A/RD4S = 320 ~ 64000 [ms]
 - XGF-RD8A = 640 ~ 64000 [ms]
- Averaging frequency for the specified time can be calculated as below;

$$\text{Averaging frequency [Times]} = \frac{\text{Average time}_{ms}}{\text{Number of channels used} \times 40_{ms}}$$

2) Frequency average

It is used to accumulate the temperature-conversion value of the specified channel for specified numbers and output the average of the sum in digital data.

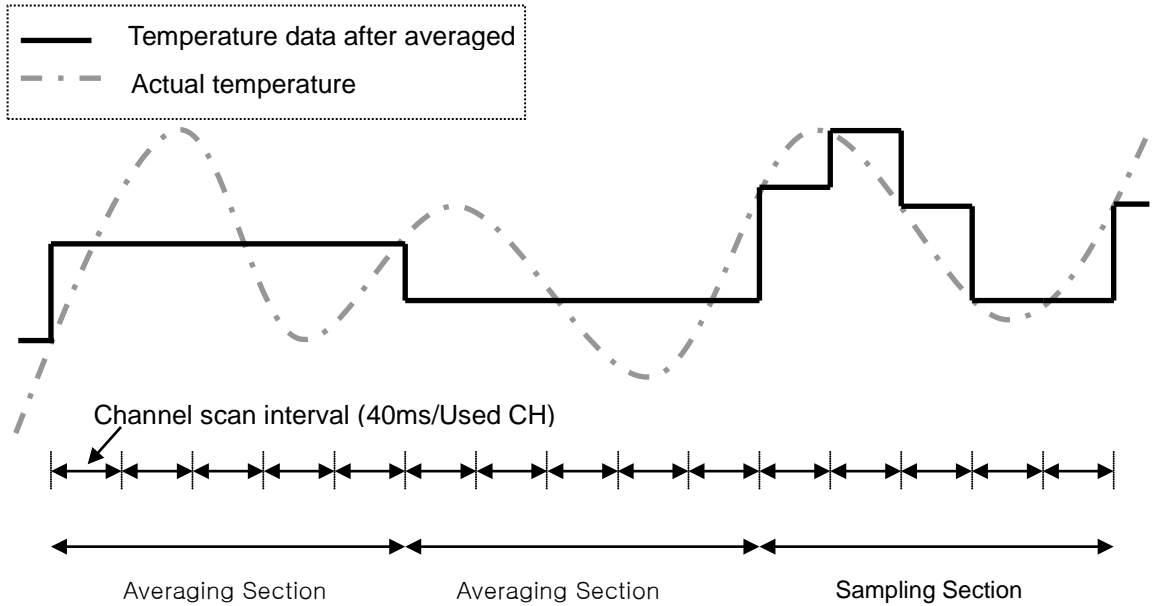

- Average frequency setting range = 2 ~ 64000 [times]
- Averaging interval for the channels used can be calculated as below;

$$\text{Averaging Interval [ms]} = \text{Average frequency} \times \text{Channels used} \times 40$$

3) Movement average

It is used to accumulate the temperature-conversion value of the specified channel for the specific number and output the average of the sum in digital data. However, the average data is output every scan for the movement average.

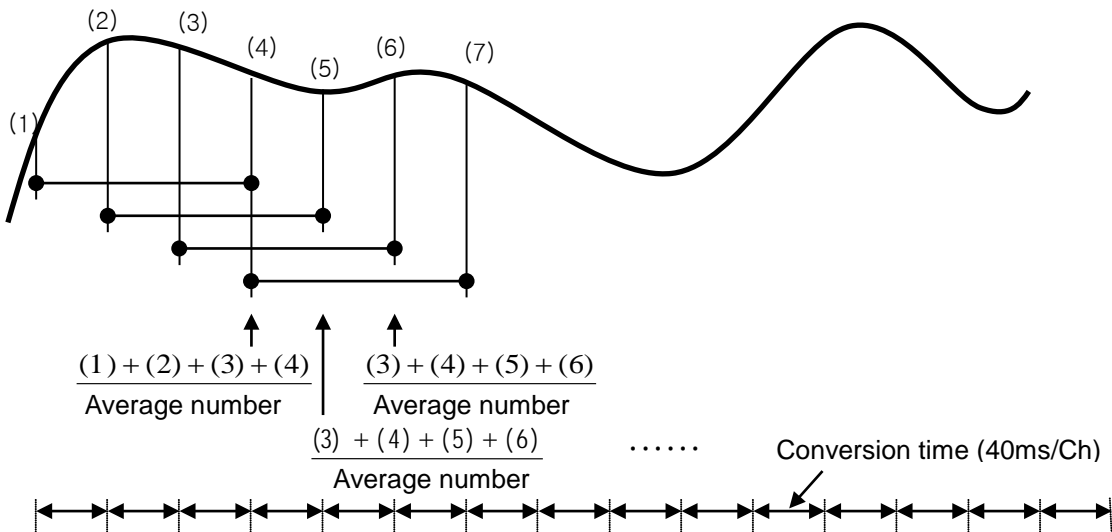

- Average number setting range = 2 ~ 100 [samples]

2.5.2 Filtering function

Based on the filter value (time-constant) which defines the temperature-conversion value of the specified channel, it performs and outputs calculation as below;

$$\text{Filtered temperature} = \frac{(\text{Previously filtered temp.} \times \text{Filter value}_{ms}) + (\text{Presently input temp.} \times 40_{ms} \times \text{Channels used})}{\text{Filter value}_{ms} + (40_{ms} \times \text{Channels used})}$$

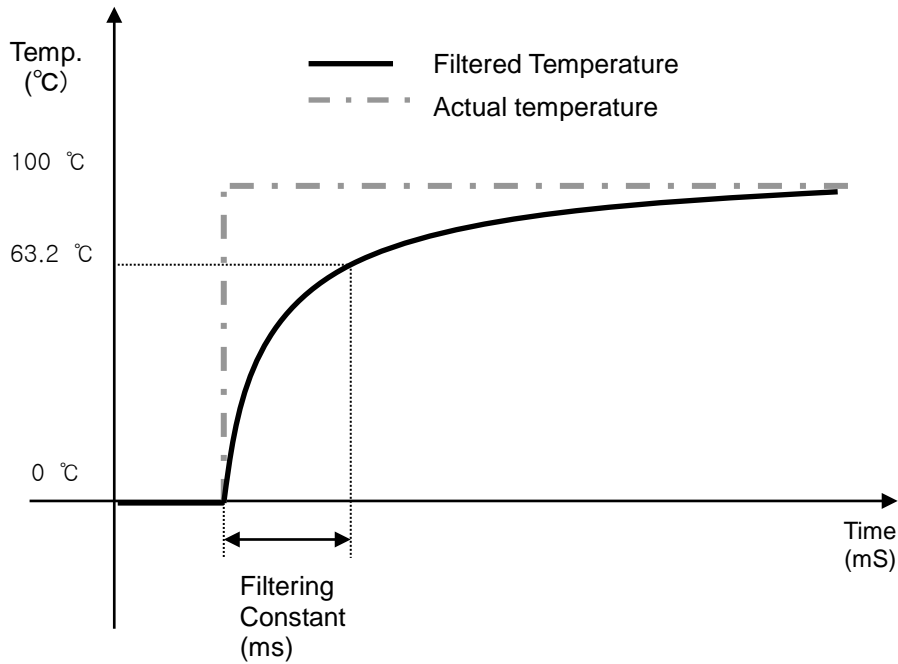

•Filtering constant setting range

- XGF-RD4A/XGF-RD4S = 160 ~ 64000 [ms]
- XGF-RD8A = 320 ~ 64000 [ms]

2.5.3 Alarming function

1) Process alarm

It is used to output an alarm if the temperature-conversion value of a specified channel exceeds the alarm-specified temperature (High-High, High, Low, Low-Low).

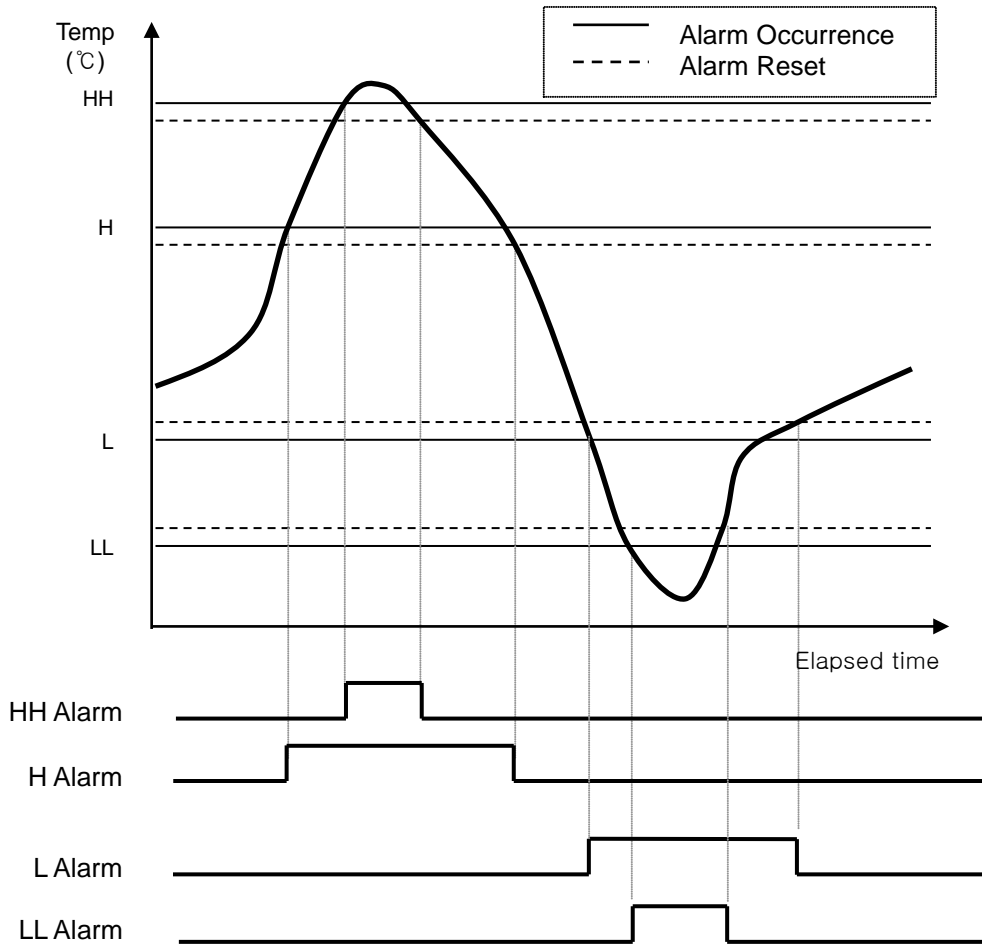

2) Input changing rate alarm (Rate Alarm)

It is used to output an alarm if temperature-conversion value change of a specified channel is larger or smaller than the alarm-specified change amount (or change rate).

In the case of Pt100,

$$\text{Change rate[\%]} = (\text{Present temperature} - \text{Temperature prior to alarm}) * 100 / (8500 - (-2000))$$

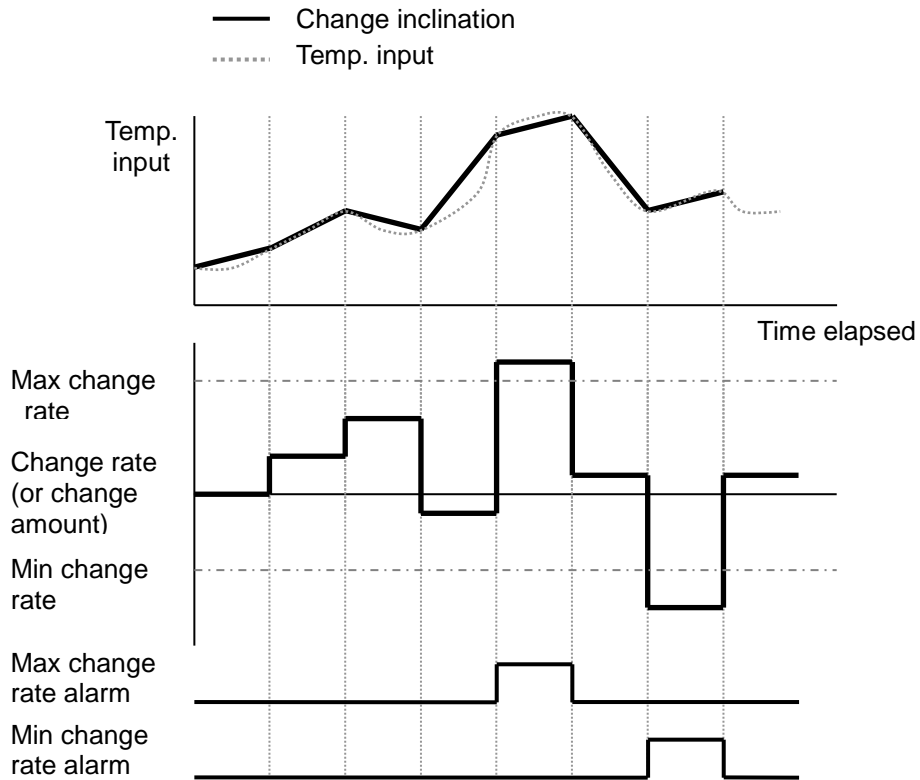

2.5.4 Max/Min displaying function

It is used to display the max/min value of temperature-conversion value changed of a specified channel for the section specified (Max/Min function enable section).

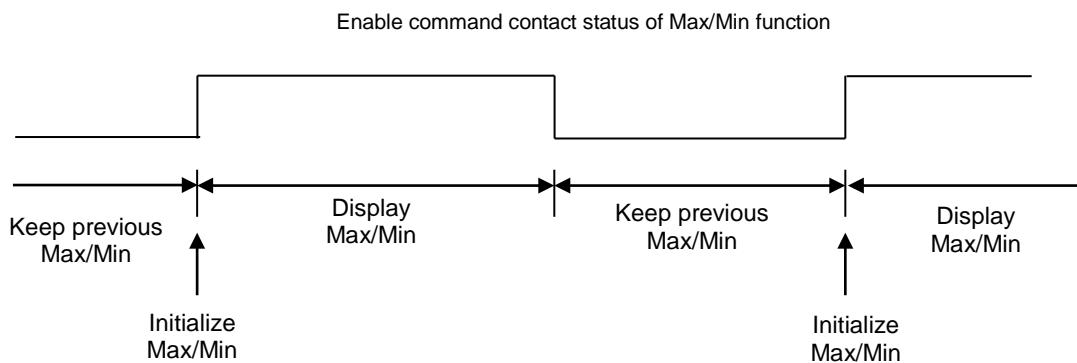

2.5.5 User offset/gain setting function (only apply to XGF-RD8A)

Reducing the temperature gap in RTD module, user can change temperature conversion value by setting offset and gain values.

When user changes the temperature conversion value with setting offset and gain function, offset/gain values which set in factory were saved without change.

When user change the temperature conversion value setting offset/gain values, it needs to 2-point temperature inputs equipment and temperature gap between two points must larger than 1°C

After setting offset/gain, the temperature-conversion value is larger than before the offset/gain setting value and display abnormal temperature value. Check the temperature conversion value using offset/gain value saved in factory. If the temperature-conversion value using offset/gain value saved in factory is normal, setting user offset/gain again because of misusing the offset/gain setting function.

In case user set offset value larger than gain value or gain value smaller than offset value, the module bring errors and the offset/gain setting value do not save. In this case user can setting gain value before setting offset value.

User offset/gain value transfer to other module using on-line module change function.

User offset/gain value which is transferred could not be accurate temperature conversion value owing to different hardware characteristic of each module. In this case user should set offset/gain setting again.

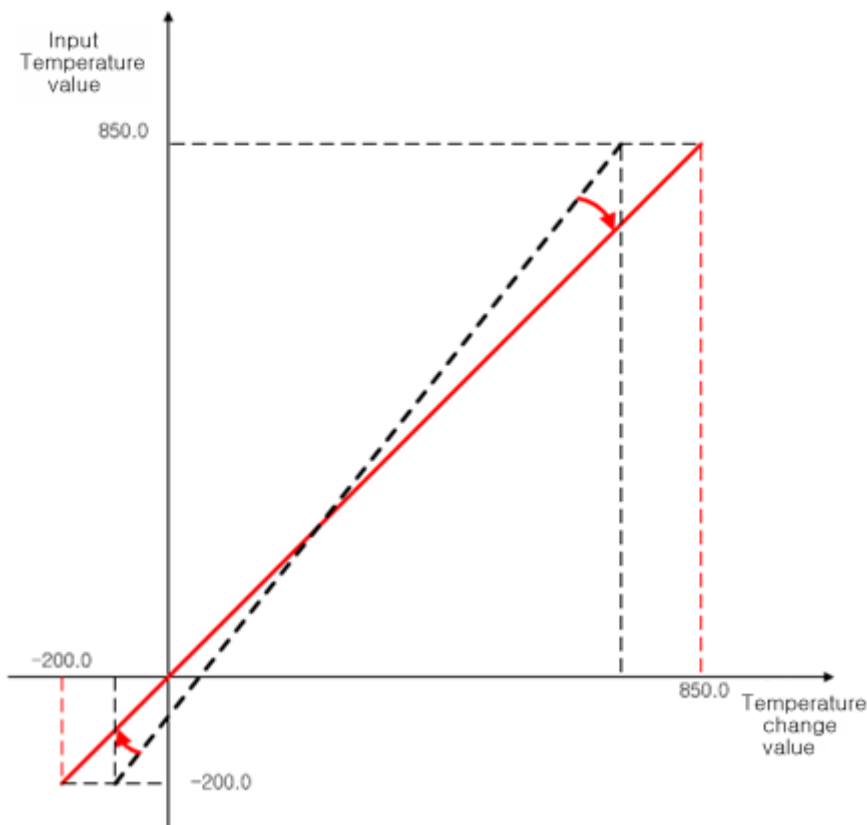

Detailed explanation of user offset/gain setting function and on-line module change function after setting user offset/gain refer to appendix 3.

Notes

- 1) User offset/gain setting can set within module's input temperature range. When setting user offset/gain, gain value is larger than offset value at least 1°C. If temperature value from equipment vibrates severely and difference between gain and offset are small, user offset/gain setting can take error.
- 2) If using a offset/gain setting, the temperature-conversion value out of offset value and gain value could not be accurate.
- 3) If setting the user offset/gain, initial offset/gain value at factory mode do not change.
- 4) when setting the user offset/gain mode, Use low vibrate device or sensor that can input temperature, accurate temperature source and temperature sense must be input to each channel.
- 5) After setting offset/gain, the temperature-converted value is larger than before the offset/gain setting value and display abnormal temperature value. check the temperature-conversion value using offset/gain value saved in factory. If the temperature-conversion value using offset/gain value saved in factory is normal, setting user offset/gain again because of misusing the offset/gain setting function.

Chapter 3 Installation and Wiring

3.1 Installation

3.1.1 Installation ambience

This module has high reliability regardless of its installation environment, but be sure to check the following for system reliability and stability.

1) Ambience requirements

Avoid installing the module in places where are subjected or exposed to :

- Water leakage and dust.
- Continuous shocks or vibrations.
- Direct sunlight.
- Dew condensation due to rapid temperature change.
- Higher or lower temperatures outside the range of 0 to 55 °C

2) Precautions during installing and wiring.

- During drilling or wiring, do not allow any wire scraps to enter into the PLC.
- Install it on places where are convenient for operation.
- Make sure that it is not located on the same panel where high voltage equipment is located.
- Make sure that the distance from the walls of duct and external equipment be 50 mm or more.
- Be sure to be grounded to locations that have good ambient noise immunity.

3.1.2 Handling precautions

From unpacking to installing the RTD input module, be sure to check the followings:

- 1) Do not drop it off, and make sure that strong shock should not be applied.
- 2) Do not unload the PCB from its case. It can cause faults.
- 3) During wiring, be sure to check any foreign matter like wire scraps should not enter into the upper side of the PLC. If any foreign matter has entered into it, always eliminate it.
- 4) Do not install or remove the module to/from base while the power supply is turned on.

3.2 Wiring

3.2.1 Wiring precautions

Let the cable for external input signals of RTD input module separated and kept away from the alternating current enough so to be free from surge or inductive noise produced from the alternating current side.

- 1) Do not keep the external input signal line of RTD input module with AC power line closely not to be affected by surge or induction noise developed by AC power.
- 2) Cable shall be selected in due consideration of ambient temperature and allowable current, whose max. size is not less than cable standard of AWG22 (0.3mm²).
- 3) Don't let the cable too close to hot device and material or in direct contact with oil for long, which will cause damage or abnormal operation due to short-circuit.
- 4) Check the polarity before wiring.
- 5) Wiring with high-voltage line or power line may produce inductive hindrance causing abnormal operation or defect.
- 6) XGF-RD8A module
 - a) Please do not wiring to twisted state of cable to the connector.
 - b) Please wiring tension does not occur between the connector and cable.
 - c) Please avoid environments with strong vibration to the cable near connector
 - d) The thickness of the wire that can be used for connector of XGF_RD8A is AWG20 ~ 28 size.

3.2.2 Wiring examples

A) XGF-RD4A/ XGF-RD8A

1) 2-wired sensor

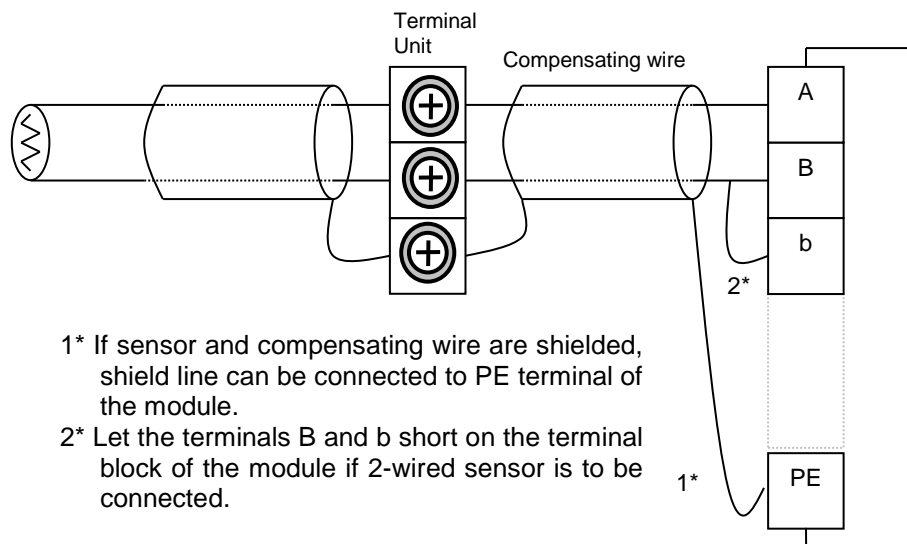

- The standard wiring method for XGF-RD4A/RD8A module is 3-wired wiring. If 2-wired or 4-wired RTD sensor is used to XGF-RD4A/RD8A module, must be maintained in the form of a 3-wired wiring, in the case a temperature vibration may occur.

2) 3-wired sensor

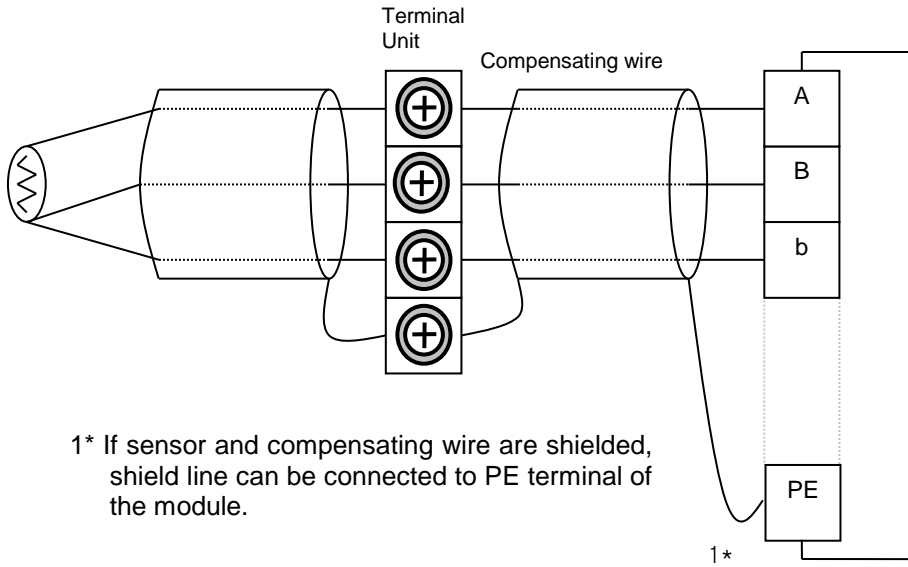

1* If sensor and compensating wire are shielded, shield line can be connected to PE terminal of the module.

3) 4-wired sensor

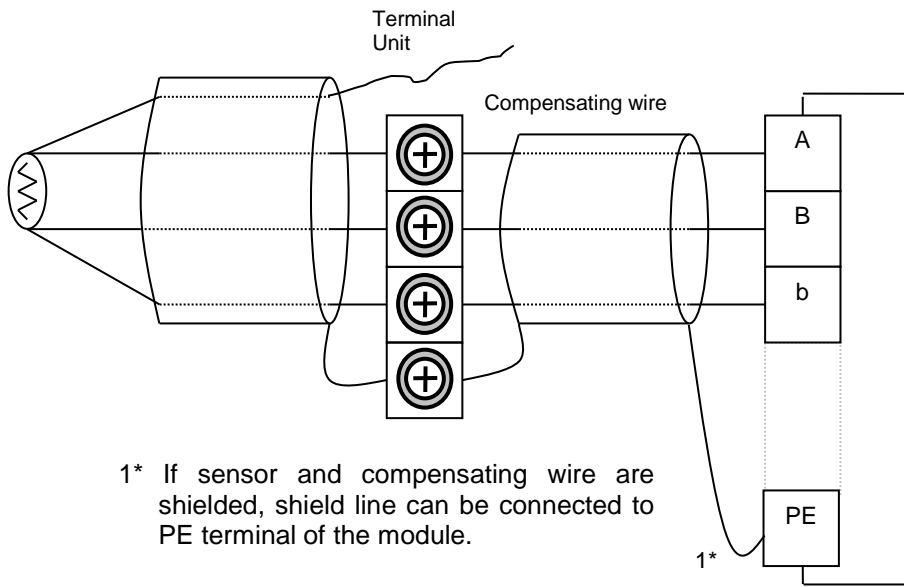

1* If sensor and compensating wire are shielded, shield line can be connected to PE terminal of the module.

2* 4-wired sensor connection is the same as in 3-wired. However, the wires of sensor are 4, the wire with an identical sign to the wire connected to terminal A shall not be connected to the module.

2) XGF-RD4S

1) 2-wired sensor

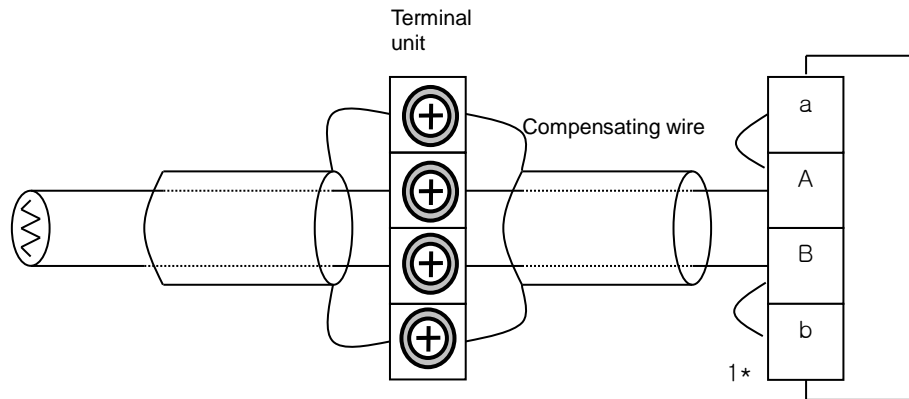

1* Let the terminals A and a, B and b short on the terminal block of the module if 2-wired sensor is to be connected.

- The standard wiring method for XGF-RD4S module is 3-wired or 4-wired wiring. If 2-wired RTD sensor is used to XGF-RD4A/RD8A module, must be maintained in the form of a 4-wired wiring, in the case a temperature vibration may occur.

2) 3-wired sensor

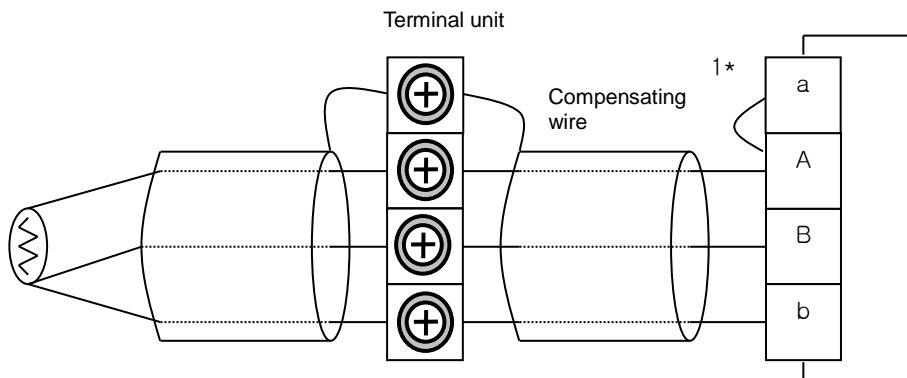

1* Let the terminals A and a short on the terminal block of the module if 3-wired sensor is to be connected

- Select the sensor type of I/O parameter to 3-wired sensor type.

3) 4-wired sensor

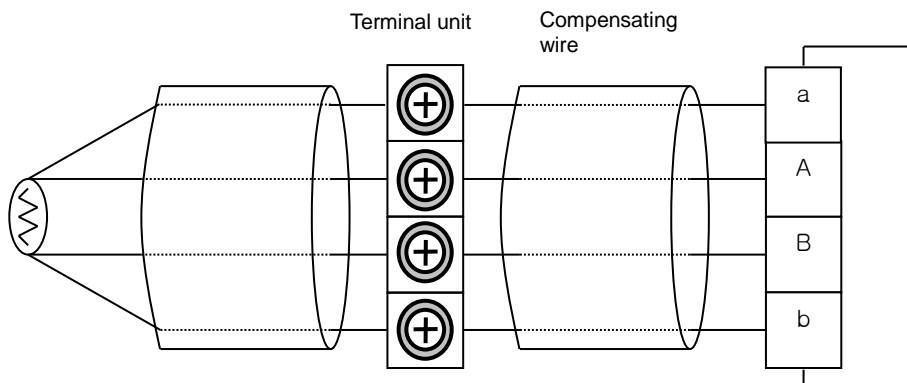

- Select the sensor type of I/O parameter to 4-wired sensor type.

3.2.3 No. of Terminal block

1) XGF-RD4A

Channel	Terminal block
CH0 A	1
CH0 B	2
CH0 b	3
-	4
CH1 A	5
CH1 B	6
CH1 b	7
-	8
CH2 A	9
CH2 B	10
CH2 b	11
-	12
CH3 A	13
CH3 B	14
CH3 b	15
-	16
-	17
FG	18

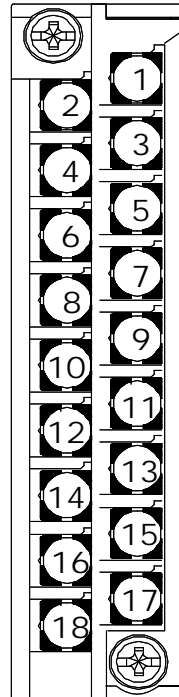

2) XGF-RD4S

Channel	Terminal block
CH0 a	1
CH0 A	2
CH0 B	3
CH0 b	4
CH1 a	5
CH1 A	6
CH1 B	7
CH1 b	8
CH2 a	9
CH2 A	10
CH2 B	11
CH2 b	12
CH3 a	13
CH3 A	14
CH3 B	15
CH3 b	16
-	17
-	18

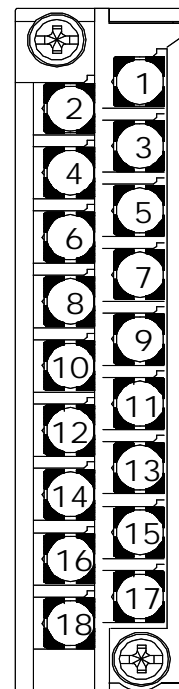

Chapter 4 Operation Setting and Monitoring

4.1 XGF-RD4A/RD4S Module

4.1.1 Operation Procedure

The processing for the operation is as shown in Fig. 4.1.

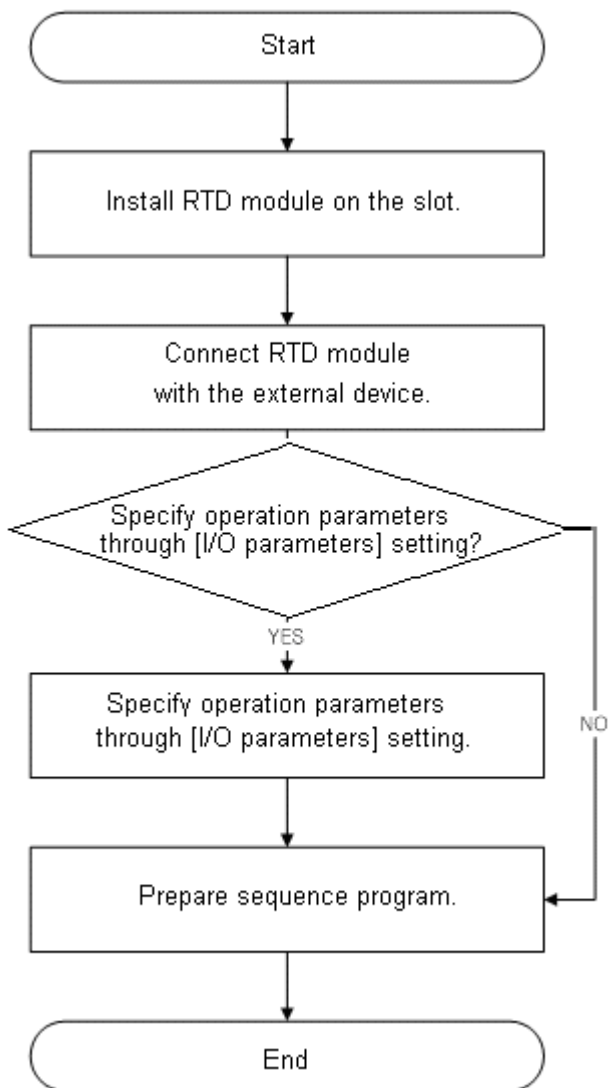

[Fig. 4. 1] Operation procedures

4.1.2 Operation Parameters Setting

Operation parameters of RTD module can be specified through [I/O parameters] of XG5000. The setting of each item is explained on the basis of the XGF-RD4A.

(1) Setting items

For the user's convenience, XG5000 provides GUI (Graphical User Interface) for parameters setting of RTD module. Setting items available through [I/O parameters] of the XG5000 project window are described below in the table 4.1.

Item	Details
[I/O parameters]	<p>(a) Specify the following setting items necessary for the module operation.</p> <ul style="list-style-type: none"> - Channel Run/Stop - Sensor type(Pt100/JPt100) - Temperature unit(°C/°F) - Filter constant - Average processing (sampling/time/frequency/movement) - Average value - Scaling data type - Scaling min. value - Scaling max. value - Process alarm H. H. Limit - Process alarm H. Limit - Process alarm L. Limit - Process alarm L. L. Limit - Process alarm HYS (hysteresis) - Type of Rate change alarm (change value/change rate) - Rate change alarm higher value - Rate change alarm lower value - Rate change alarm period <p>(b) The data specified by user through S/W package will be saved on RTD module when [I/O Parameters] are downloaded. In other words, the point of time when [I/O Parameters] are saved on the module has nothing to do with PLC CPU's status RUN or STOP.</p>

[Table 4. 1] Function of [I/O Parameters]

- (2) How to use [I/O parameters]
 - (a) Run XG5000 to create a project. (Refer to XG5000 programming manual for details on how to create the project)
 - (b) Double-click [I/O parameters] on the project window.

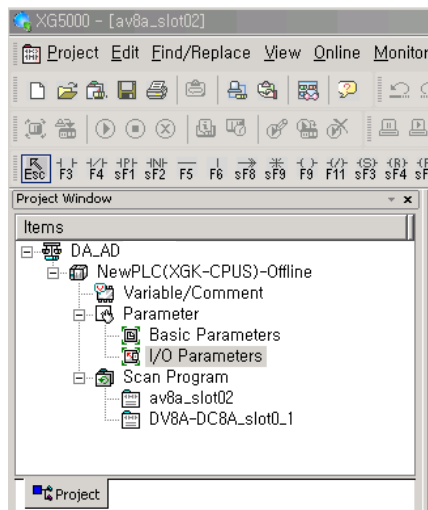

- (c) On the 'I/O parameters setting' screen, find and click the slot of the base where RTD module is installed on. It is supposed that RTD module is installed on Base No.0, Slot No.2 in this description.

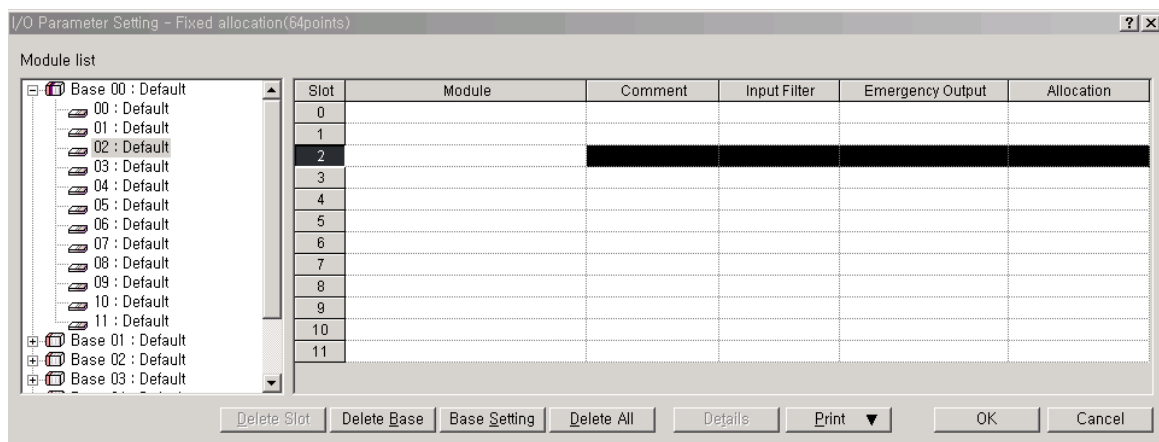

(d) Click the arrow button on the screen to display the screen where an applicable module can be selected. Search for the applicable module to select.

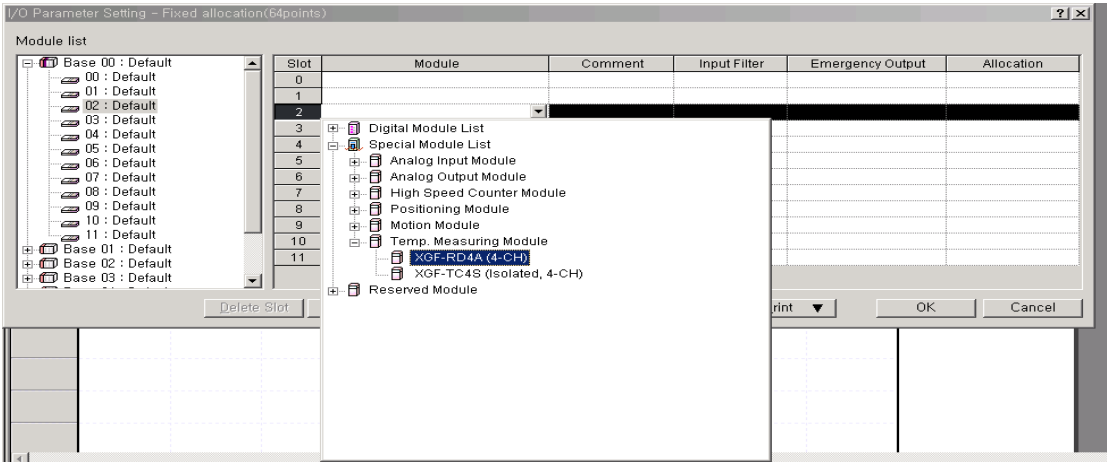

(e) After the module selected, click [Details].

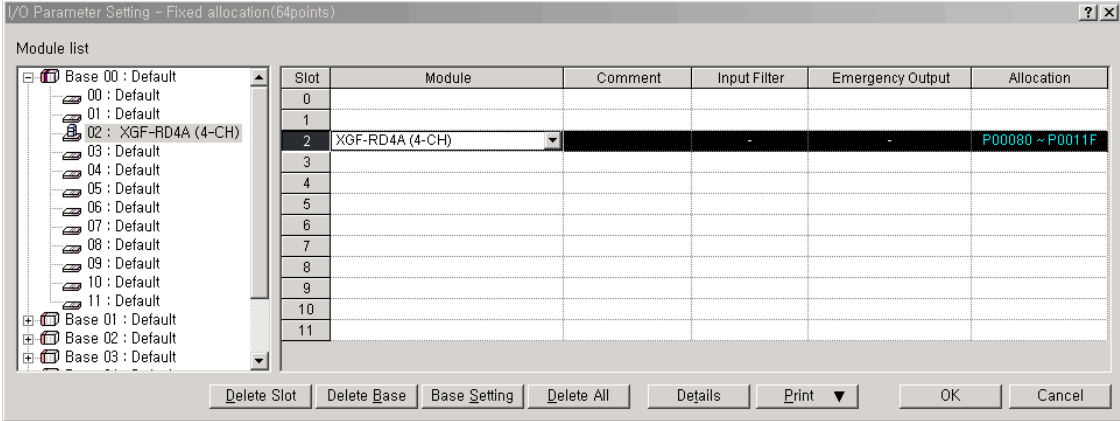

- (f) A screen will be displayed to specify parameters for respective channels as shown below. Click a desired item to display parameters to set for respective items.

Parameter	CH 0	CH 1	CH 2	CH 3
<input type="checkbox"/> Channel status	Disable	Disable	Disable	Disable
<input type="checkbox"/> Sensor type	PT100	PT100	PT100	PT100
<input type="checkbox"/> Temp. unit	Celsius	Celsius	Celsius	Celsius
Filter constant	0	0	0	0
<input type="checkbox"/> Average processing	Sampling	Sampling	Sampling	Sampling
Average value	0	0	0	0
<input type="checkbox"/> Scalling data type	Bipolar	Bipolar	Bipolar	Bipolar
Scalling min. value	-32768	-32768	-32768	-32768
Scalling max. value	32767	32767	32767	32767
Process alarm H.H.Limit	0	0	0	0
Process alarm H.Limit	0	0	0	0
Process alarm L.Limit	0	0	0	0
Process alarm L.L.Limit	0	0	0	0
Process alarm HYS	0	0	0	0
<input type="checkbox"/> RCA type	Change-Value	Change-Value	Change-Value	Change-Value
RCA high limit	0	0	0	0
RCA low limit	0	0	0	0
RCA period	40	40	40	40

- 1) Channel status: Select Enable or Disable. Channel to operate is to be 'Enable'.

Parameter	CH 0	CH 1	CH 2	CH 3
<input checked="" type="checkbox"/> Channel status	Enable	Enable	Enable	Enable
<input type="checkbox"/> Sensor type	Disable	PT100	PT100	PT100
<input type="checkbox"/> Temp. unit	Enable	Celsius	Celsius	Celsius
Filter constant	0	0	0	0
<input type="checkbox"/> Average processing	Sampling	Sampling	Sampling	Sampling
Average value	0	0	0	0
<input type="checkbox"/> Scalling data type	Bipolar	Bipolar	Bipolar	Bipolar
Scalling min. value	0	-32768	-32768	-32768
Scalling max. value	10000	32767	32767	32767
Process alarm H.H.Limit	3000	0	0	0
Process alarm H.Limit	2170	0	0	0
Process alarm L.Limit	2070	0	0	0
Process alarm L.L.Limit	0	0	0	0
Process alarm HYS	0	0	0	0
<input type="checkbox"/> RCA type	Change-Value	Change-Value	Change-Value	Change-Value
RCA high limit	0	0	0	0
RCA low limit	0	0	0	0
RCA period	40	40	40	40

2) Sensor type: Select a sensor type to use RTD sensor.

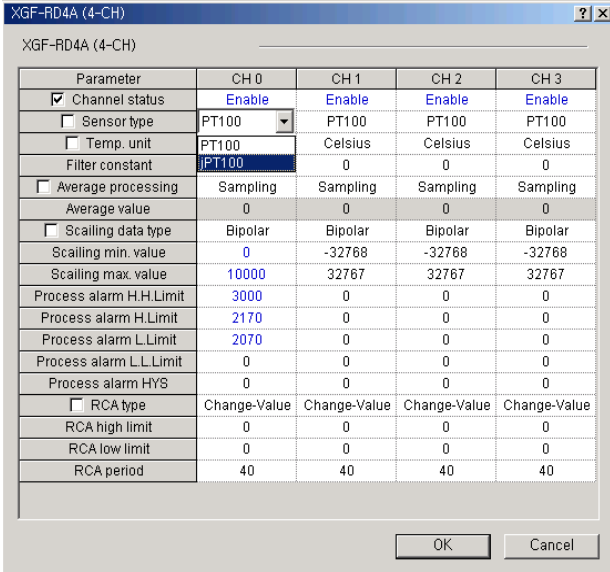

- In case of XGF-RD4S, Select 3-wired or 4-wired according to sensor wiring method.

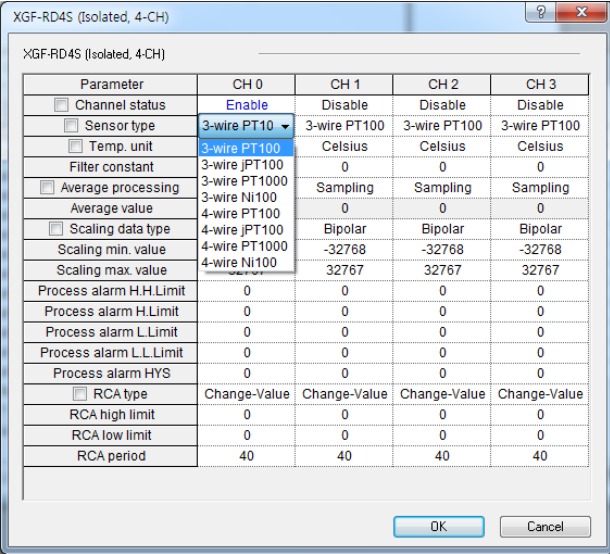

- 3) Temperature unit: Select the output temperature unit among Celsius and Fahrenheit.

XGF-RD4A (4-CH)

Parameter	CH 0	CH 1	CH 2	CH 3
<input type="checkbox"/> Channel status	Enable	Disable	Disable	Disable
<input type="checkbox"/> Sensor type	PT100	PT100	PT100	PT100
<input type="checkbox"/> Temp. unit	Celsius	Celsius	Celsius	Celsius
Filter constant	Celsius	0	0	0
<input type="checkbox"/> Average processing	Fahrenheit	Sampling	Sampling	Sampling
Average value	0	0	0	0
<input type="checkbox"/> Scaling data type	Bipolar	Bipolar	Bipolar	Bipolar
Scaling min. value	-32768	-32768	-32768	-32768
Scaling max. value	32767	32767	32767	32767
Process alarm H.H.Limit	0	0	0	0
Process alarm H.Limit	0	0	0	0
Process alarm L.Limit	0	0	0	0
Process alarm L.L.Limit	0	0	0	0
Process alarm HYS	0	0	0	0
<input type="checkbox"/> RCA type	Change-Value	Change-Value	Change-Value	Change-Value
RCA high limit	0	0	0	0
RCA low limit	0	0	0	0
RCA period	40	40	40	40

OK Cancel

- 4) Setting value input: If an input item is selected, the input range of the applicable setting value will be displayed at the bottom of the window.

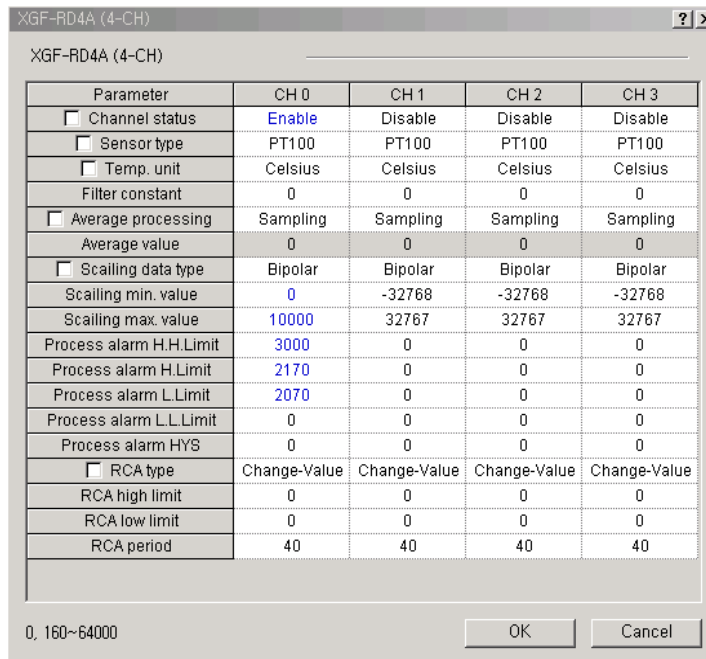

- 5) Incorrect setting: If any incorrect value is input, it will be turned red as shown below; (if input range is incorrect)

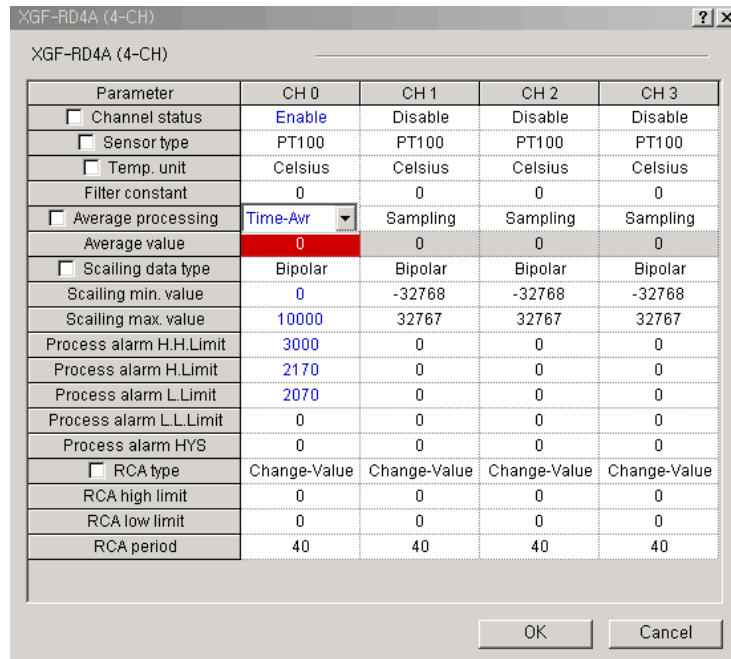

6) Applying identical settings to all channels

Check the check box on the parameter menu to select and change setting of a channel then the setting value of all the channels will be identical to changed setting value. Fig. 4.2 shows an example with this function that channel status is changed to 'Enable' of all the channels.

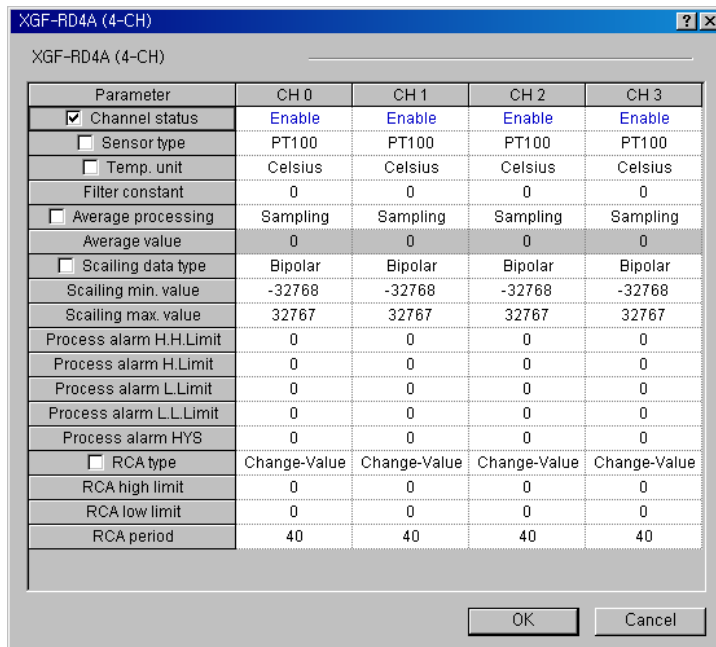

[Fig. 4. 2] Change of all the channel parameters

4.1.3 Functions of Special Module Monitoring

Functions of Special Module Monitoring are as described below in table 4.2.

[Table 4. 2] Functions of Special Module Monitoring

Item	Details	Remarks
[Special Module Monitoring]	(1) Monitor/Test Through applicable XG5000 menu of [Monitor] -> [Special Module Monitoring], temperature-converted value can be monitored and the operation of RTD module can be tested. (2) Monitoring the max./min. value The max./min. value of the channel can be monitored during Run. However, the max./min. value displayed here is based on the present value shown on the screen. Accordingly, when [Monitoring/Test] screen is closed, the max./min. value will not be saved.	

Notes

The screen may not be normally displayed due to insufficient system resource. In such a case, close the screen and finish other applications and restart XG5000.

4.1.4 Precautions

- The parameters specified to test RTD module on the “Special Module Monitoring” screen will be deleted when “Special Module Monitoring” screen is closed. In other words, the parameters of RTD module specified on the “Special Module Monitoring” screen will not be saved in [I/O parameters] located on the left tap of XG5000.

The screenshot shows the 'Special Module Monitor' window for XGF-RD4A (4-CH). It contains two main tables. The first table lists parameters for four channels (CH 0, CH 1, CH 2, CH 3), including Temperature value, Scalling value, Min. temp value, Max. temp value, and Input change(value/rate). The second table provides detailed settings for CH 0, comparing 'Setting value' and 'Current value' for various parameters like Channel status, Sensor type, Temp. unit, Filter constant, Average processing, Average value, Scalling data type, Scalling min. value, Scalling max. value, Process alarm limits, RCA type, RCA high limit, RCA low limit, and RCA period. A callout box with an arrow points to the 'Current value' column, indicating that these values are not saved in the I/O parameters.

Item	CH 0	CH 1
Temperature value	0	0
Scalling value	0	0
Min. temp value	0	0
Max. temp value	0	0
Input change(value/rate)	0	0
Item	CH 2	CH 3
Temperature value	0	0
Scalling value	0	0
Min. temp value	0	0
Max. temp value	0	0
Input change(value/rate)	0	0
FLAG Monito		FLAG Monitor

Item	Setting value	Current value
Channel		CH 0
Channel status	Disable	Disable
Sensor type	PT100	PT100
Temp. unit	Celsius	Celsius
Filter constant	0	0
Average processing	Sampling	Sampling
Average value	0	0
Scalling data type	Bipolar	Bipolar
Scalling min. value	-32768	-32768
Scalling max. value	32767	32767
Process alarm H.H.Limit	0	0
Process alarm H.Limit	0	0
Process alarm L.Limit	0	0
Process alarm L.Limit	0	0
Process alarm HYS	0	0
RCA type	Change-Value	Change-Value
RCA high limit	0	0
RCA low limit	0	0
RCA period	40	40

Not saved in [I/O parameters].

- Test function of [Special Module Monitoring] operates with the sequence program stopped and not available during run.
- Test function of [Special Module Monitoring] is provided for user to check without sequence programming if the RTD module operates normally. If RTD module is to be used for other purposes than test, use parameters setting function in [I/O parameters].

4.1.5 Special Module Monitoring

How to use Special Module Monitoring will be described below.
This is described based on XGF-RD4A.

(1) Run [Special Module Monitoring]

Run Special Module Monitoring by selecting [On-Line] -> [Connect] and [Monitor] -> [Special Module Monitoring]. If the status is not [On-Line], [Special Module Monitoring] menu will not be activated.

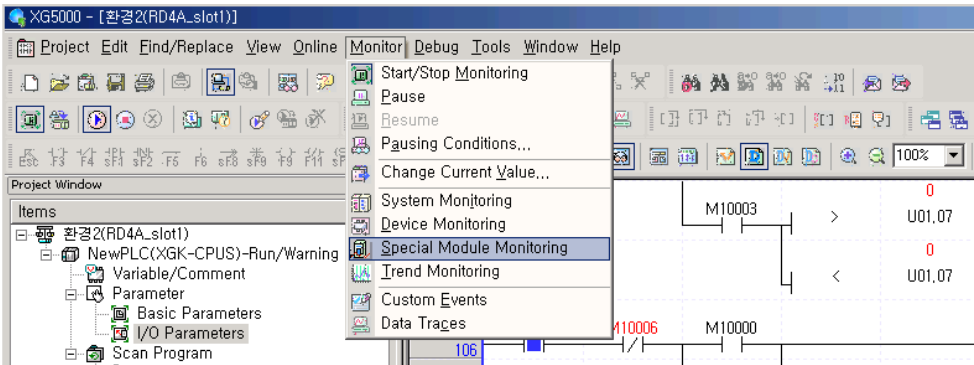

(2) How to use [Special Module Monitoring]

(a) With XG5000 connected to PLC CPU (on-line status), click [Monitor] -> [Special Module Monitoring] to display 'Special Module List' screen described in [Fig. 5.1] showing base/slot information in addition to special module type. The module installed on the present PLC system will be displayed on the list of dialog box.

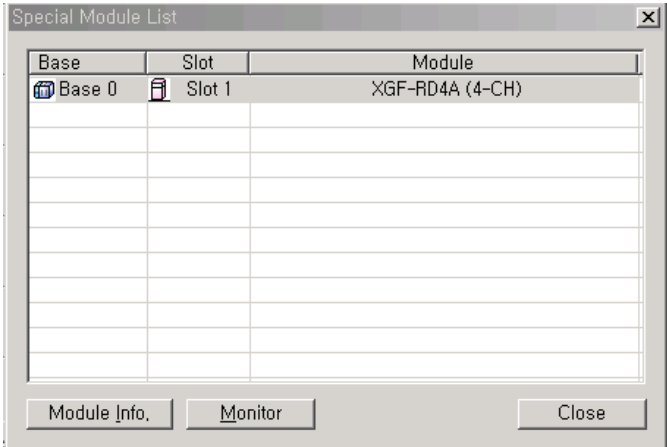

[Fig. 5. 1] Screen of [Special Module List]

- (b) Select Special Module in [Fig. 5.1] and click [Module Info.] to display the information as in [Fig. 5.2].

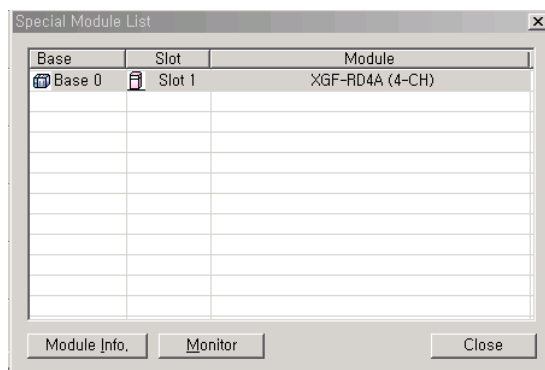

[Fig. 5. 2] Screen of [Module Information]

- (c) Click [Monitor] on the “Special Module List” screen in Fig. 5.1 to display [Special Module Monitor] screen as in Fig. 5.3, where 4 options are available such as [FLAG Monitor], [Start Monitoring], [Test] and [Close]. RTD module’s temperature-converted value and scaling value are displayed on the monitor screen at the top of the screen, and parameters items of respective modules are displayed for individual setting on the test screen at the bottom of the screen.

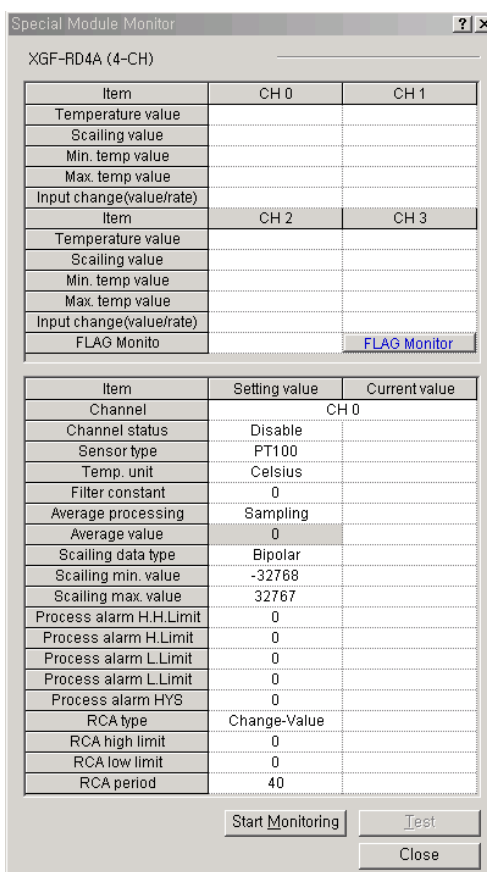

[Fig. 5. 3] Screen of [Special Module Monitoring]

- 1) [Start Monitoring]: Click [Start Monitoring] to display temperature-converted value of the presently operated channel. [Fig. 5.4] is the monitoring screen displayed when the whole channels are in Stop status. In the present value field at the screen bottom, presently specified parameters of RTD module are displayed.

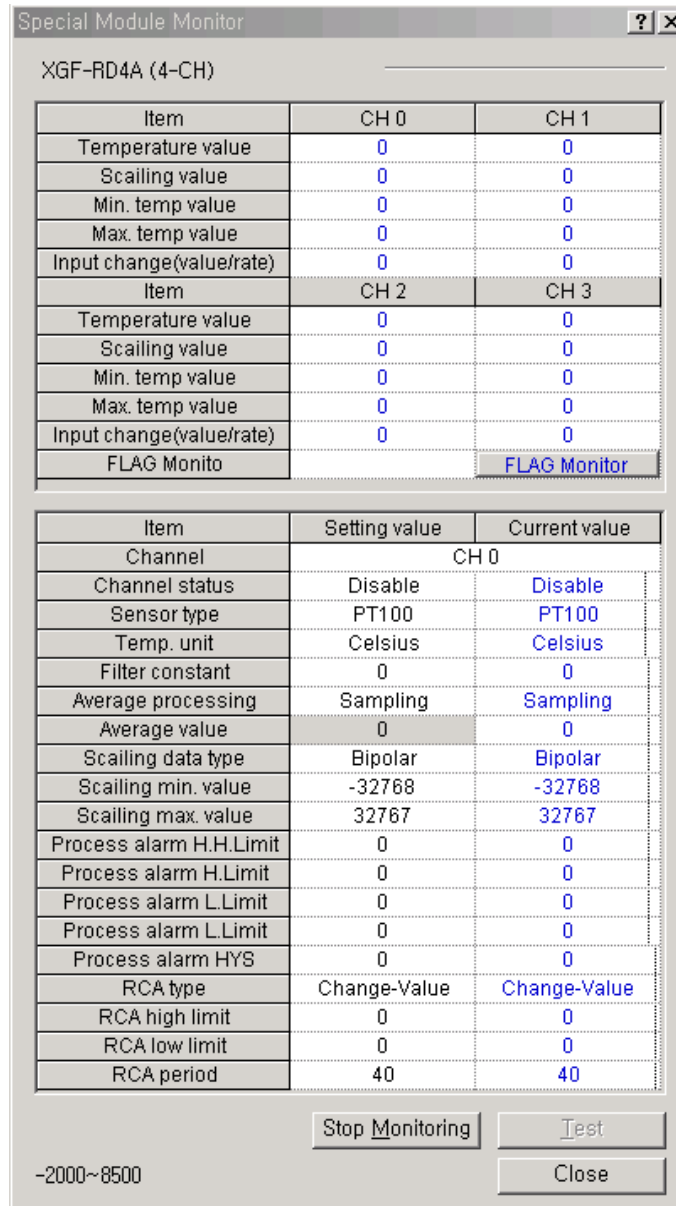

[Fig. 5. 4] Execution screen of [Start Monitoring]

- 2) [Test]: [Test] is used to change the presently specified parameters of RTD module. Click the setting value at the bottom field of the screen to change parameters. [Fig. 5.5] will be displayed after [Test] is executed with channel 1's input sensor type changed to PT100 in the state of input not wired.

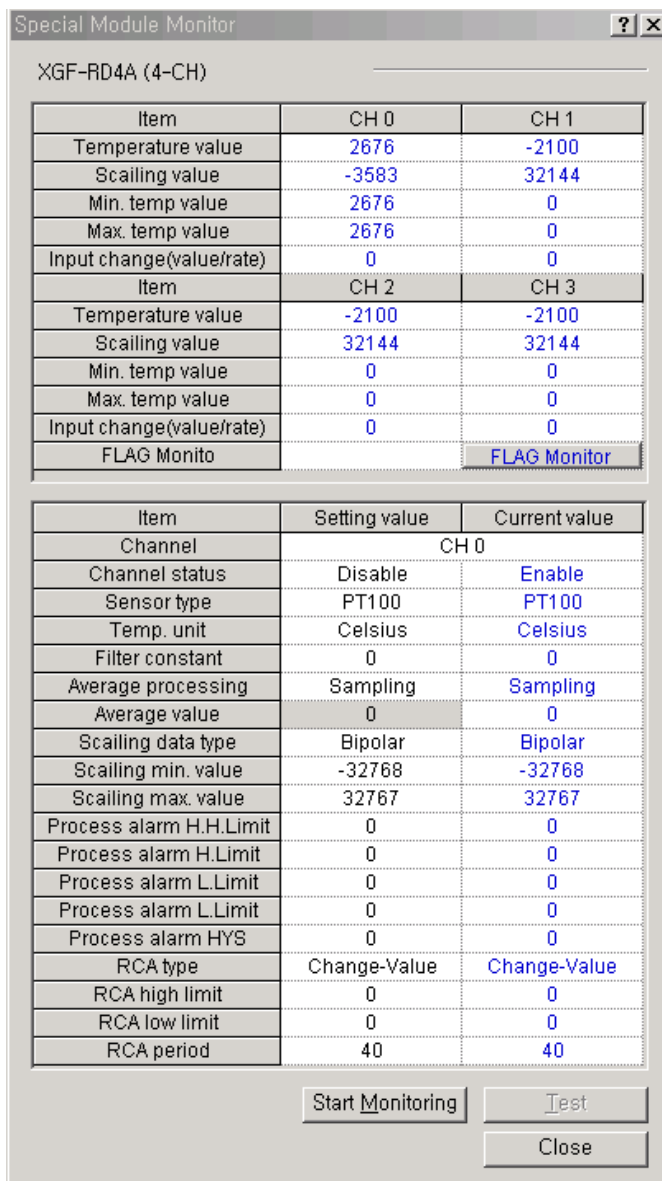

[Fig. 5. 5] Execution screen of [Test]

- 3) [Max/Min active]: Click 'FLAG Monitor' on the upper screen to set [Max/Min active] of the RTD module Enabled and close the command screen to monitor the max./min. temperature-converted value as shown below;

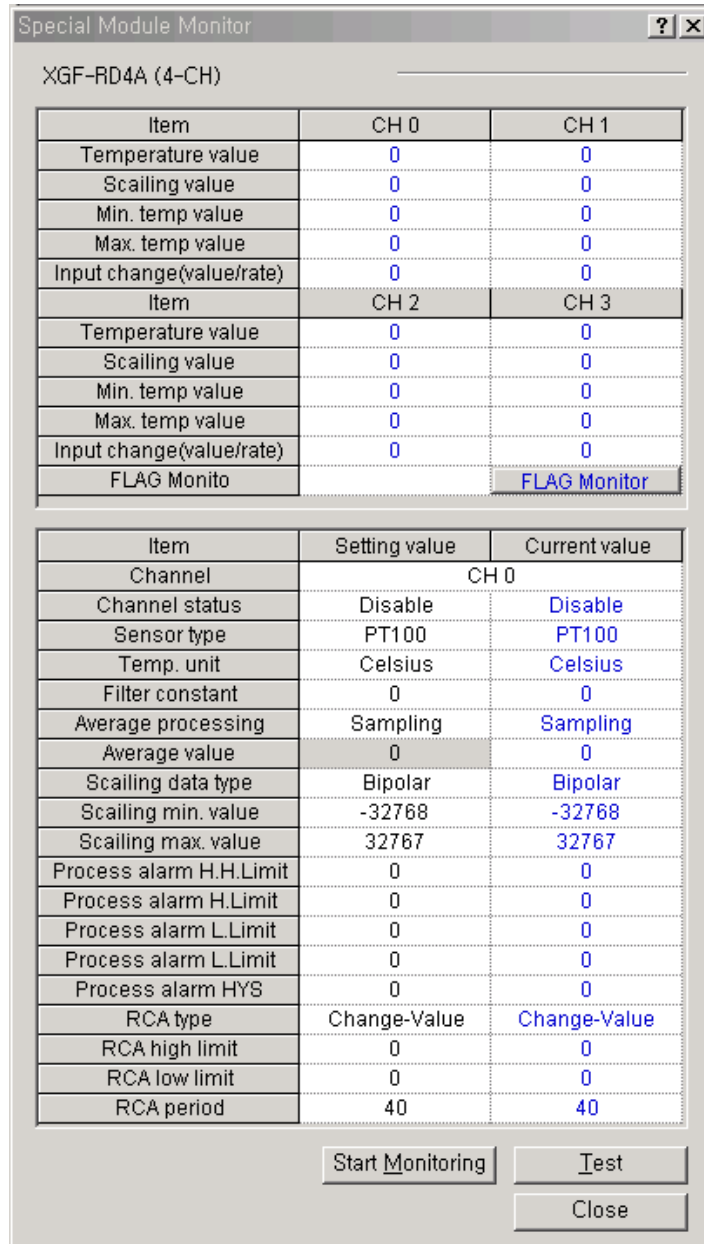

[Fig. 4. 6] Execution screen of [Search for max./min. value]

- (4) [Close]: [Close] is used to escape from the monitoring/test. When the monitoring/test screen is closed, the max. value, the min. value and the present value will not be saved any more.

4.1.6 Automatic Registration of U Device

Automatic registration function of XG5000 U device is described below.
 The setting of each item is explained on the basis of the XGF-RD4A.

(1) Automatic registration of U device

See the special module information specified in [I/O parameters] to register the variable of each module automatically. User can modify the variables and descriptions.

[Sequence]

(a) Specify the special module of the slot on [I/O parameters].

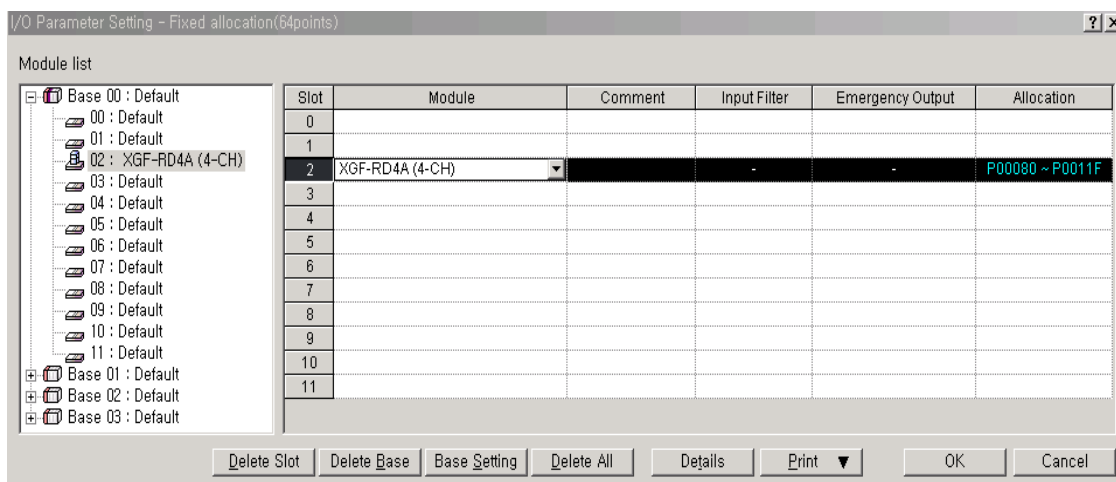

(b) Double-click [Variable/Comment].

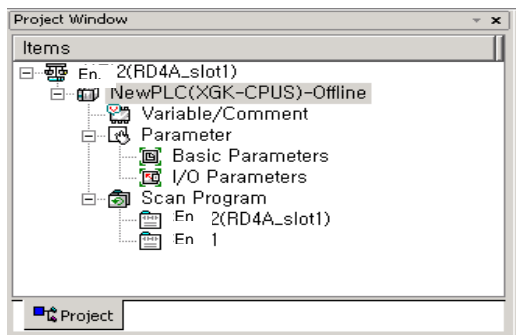

(c) Select 'Register U device' on the 'Edit' menu.

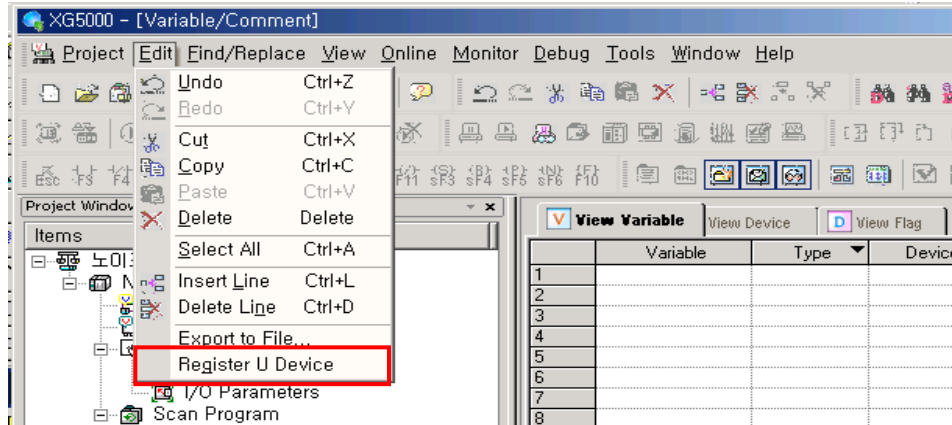

(d) Click 'Yes'.

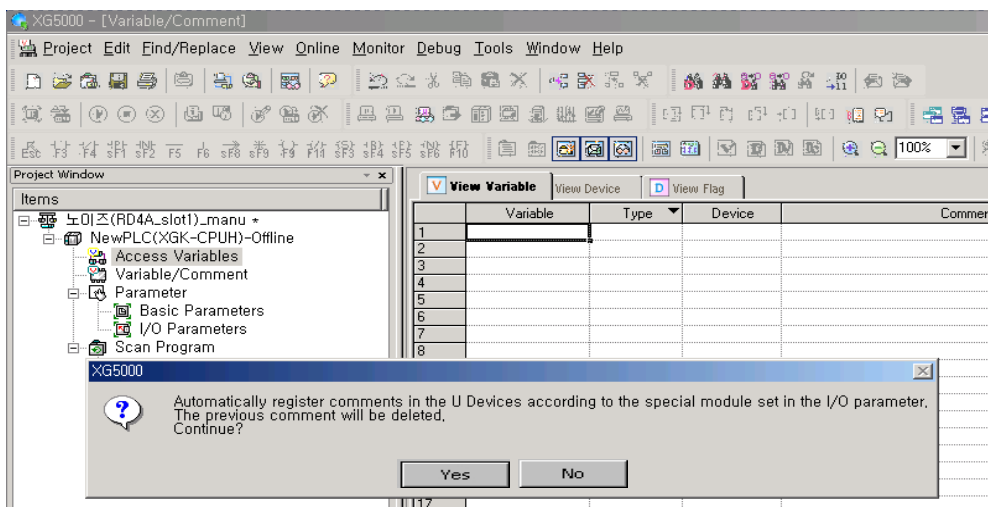

(e) Variables will be registered as shown below on the screen.

	Variable	Type	Device	Comment
1	_02_CH0_ADJERR	BIT	U02.00.0	Temp. Measuring Module : CH0 Offset/Gain Error
2	_02_CH1_ADJERR	BIT	U02.00.1	Temp. Measuring Module : CH1 Offset/Gain Error
3	_02_CH2_ADJERR	BIT	U02.00.2	Temp. Measuring Module : CH2 Offset/Gain Error
4	_02_CH3_ADJERR	BIT	U02.00.3	Temp. Measuring Module : CH3 Offset/Gain Error
5	_02_EEPROMERR	BIT	U02.00.D	Temp. Measuring Module : Offset/Gain Backup Error
6	_02_WDT_ERR	BIT	U02.00.E	Temp. Measuring Module : Module H/W Error
7	_02_RDY	BIT	U02.00.F	Temp. Measuring Module : Module Ready
8	_02_CH0_ACT	BIT	U02.01.0	Temp. Measuring Module : CH0 Running
9	_02_CH1_ACT	BIT	U02.01.1	Temp. Measuring Module : CH1 Running
10	_02_CH2_ACT	BIT	U02.01.2	Temp. Measuring Module : CH2 Running
11	_02_CH3_ACT	BIT	U02.01.3	Temp. Measuring Module : CH3 Running
12	_02_CH0_BOUT	BIT	U02.01.4	Temp. Measuring Module : CH0 Input Disconnection
13	_02_CH1_BOUT	BIT	U02.01.5	Temp. Measuring Module : CH1 Input Disconnection
14	_02_CH2_BOUT	BIT	U02.01.6	Temp. Measuring Module : CH2 Input Disconnection
15	_02_CH3_BOUT	BIT	U02.01.7	Temp. Measuring Module : CH3 Input Disconnection
16	_02_CH0_SETERR	BIT	U02.01.8	Temp. Measuring Module : CH0 Setting Error
17	_02_CH1_SETERR	BIT	U02.01.9	Temp. Measuring Module : CH1 Setting Error
18	_02_CH2_SETERR	BIT	U02.01.A	Temp. Measuring Module : CH2 Setting Error
19	_02_CH3_SETERR	BIT	U02.01.B	Temp. Measuring Module : CH3 Setting Error
20	_02_CH0_PVALL	BIT	U02.02.0	Temp. Measuring Module : CH0 Process Alarm Ultra Lower Limit Flag
21	_02_CH1_PVAL	BIT	U02.02.1	Temp. Measuring Module : CH0 Process Alarm Lower Limit Flag

(2) Save variables

Chapter 4 Operation Setting and Monitoring

- (a) Contents in the 'View variables' tap can be saved in a text file.
- (b) Click 'Save in a text file' on the 'Edit' menu.
- (c) Contents in the 'View variables' tap will be saved in a text file..

(3) View variables in the program

- (a) Example program of XG5000 is as shown below;

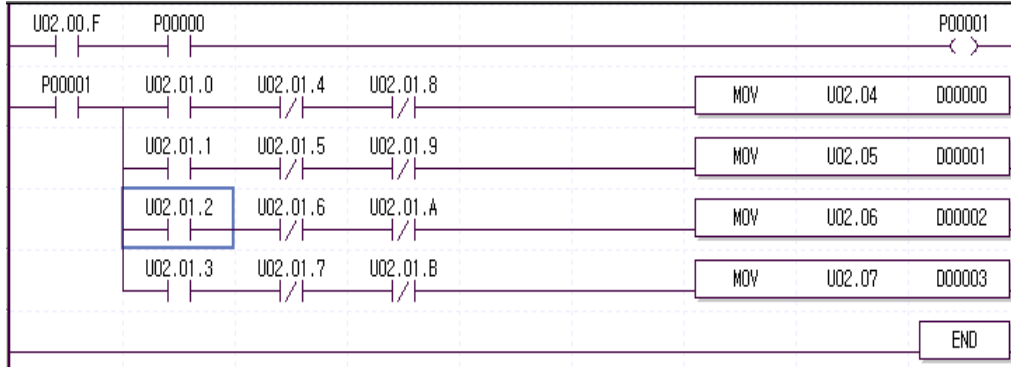

- (b) Click 'View variables' on the tap menu of 'View'. Devices will be changed to variables.

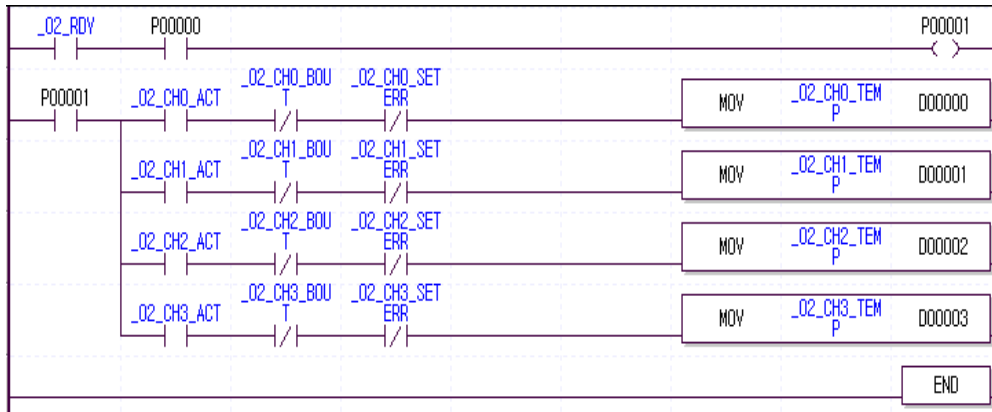

- (c) Click 'Devices/Variables' on the menu of 'View' to see devices and variables at a time.

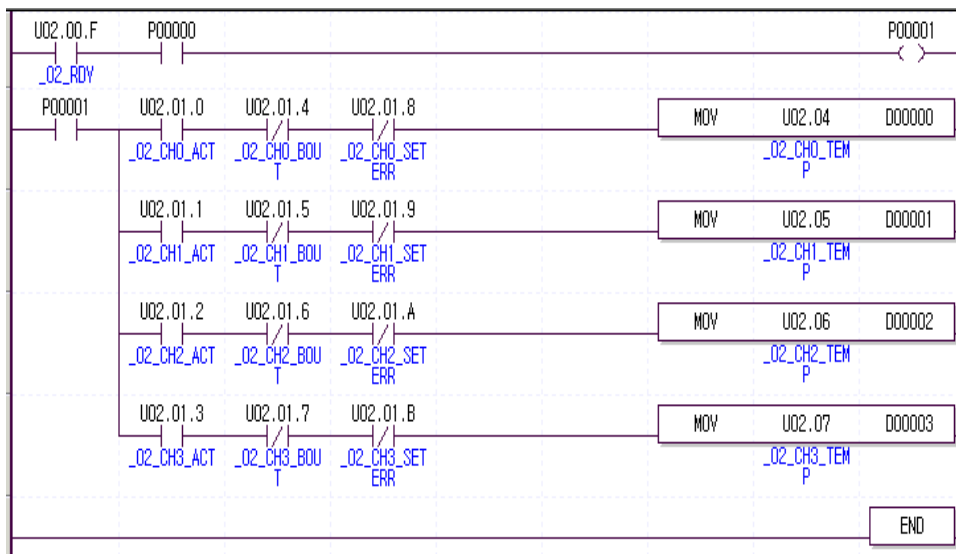

(d) Click 'Devices/Comments' on the menu of 'View' to see devices and descriptions at a time.

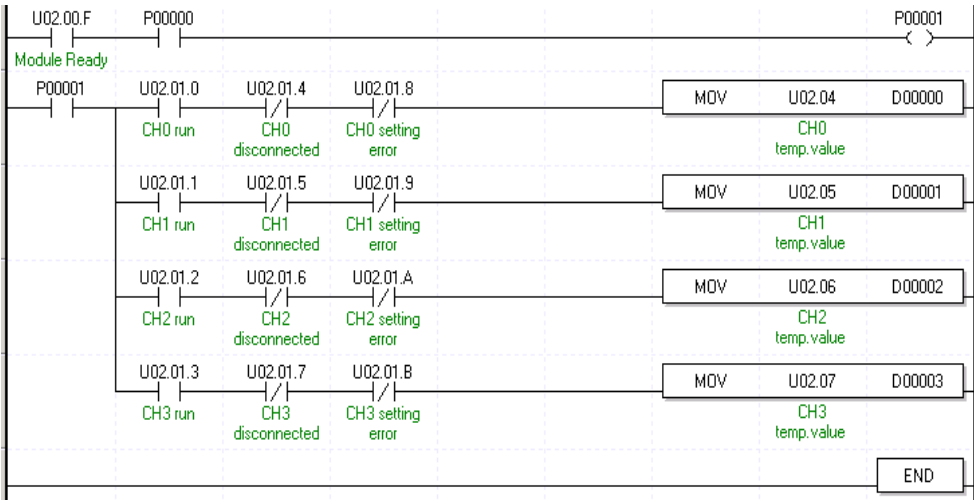

Chapter 4 Operation Setting and Monitoring

4.2 XGF-RD8A Module

4.2.1 Operation Procedure

The processing for the operation is as shown in Fig. 4.8.

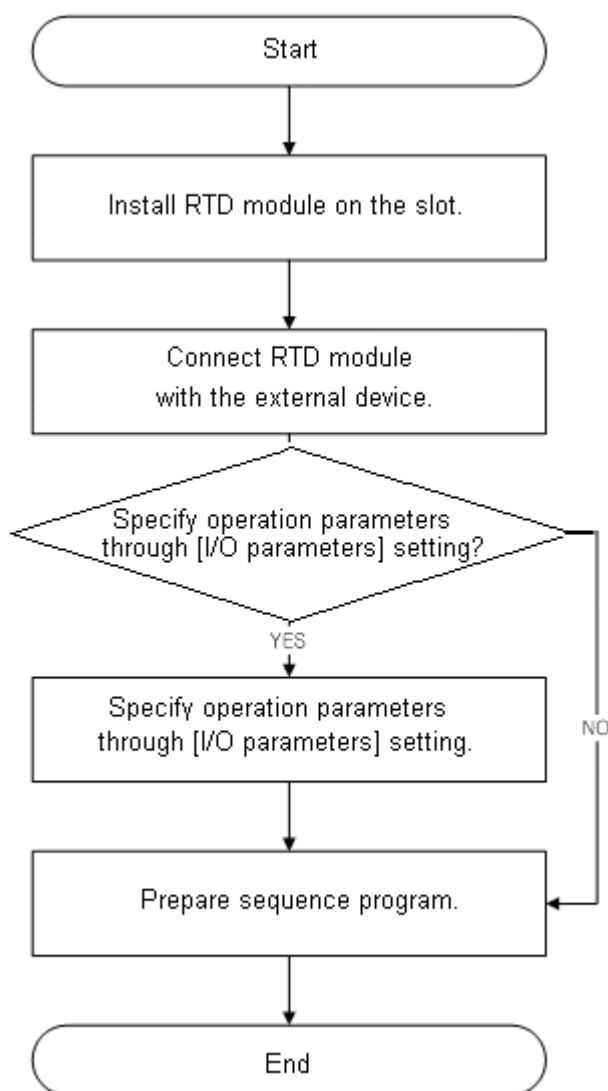

[Fig. 4. 8] Operation procedures

4.2 .2 Operation Parameters Setting

Operation parameters of RTD module can be specified through [I/O parameters] of XG5000.

Following explanation is basis on XGF-RD8A module.

(1) Setting items

For the user's convenience, XG5000 provides GUI (Graphical User Interface) for parameters setting of RTD module. Setting items available through [I/O parameters] of the XG5000 project window are described below in the table 4.3.

Item	Details
[I/O parameters]	<p>(a) Specify the following setting items necessary for the module operation.</p> <ul style="list-style-type: none"> A. Channel Run/Stop B. Sensor type(Pt100/JPt100) C. Temperature unit(°C/°F) D. Filter constant E. Average processing (sampling/time/frequency/movement) F. Average value G. Scaling data type H. Scaling min. value I. Scaling max. value J. Process alarm H. H. Limit K. Process alarm H. Limit L. Process alarm L. Limit M. Process alarm L. L. Limit N. Process alarm HYS (hysteresis) O. Type of Rate change alarm (change value/change rate) P. Rate change alarm higher value Q. Rate change alarm lower value R. Rate change alarm period <p>(b) The data specified by user through S/W package will be saved on RTD module when [I/O Parameters] are downloaded. In other words, the point of time when [I/O Parameters] are saved on the module has nothing to do with PLC CPU's status RUN or STOP.</p>

[Table 4. 3] Function of [I/O Parameters]

(2) How to use [I/O parameters]

- (a) Run XG5000 to create a project. (Refer to XG5000 programming manual for details on how to create the project)
- (b) Double-click [I/O parameters] on the project window.

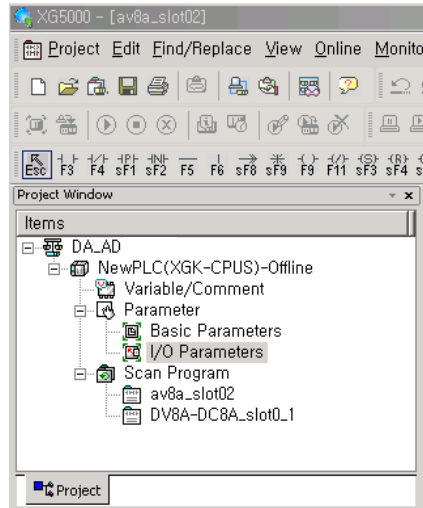

- (c) On the 'I/O parameters setting' screen, find and click the slot of the base where RTD module is installed on. It is supposed that RTD module is installed on Base No.0, Slot No.2 in this description.

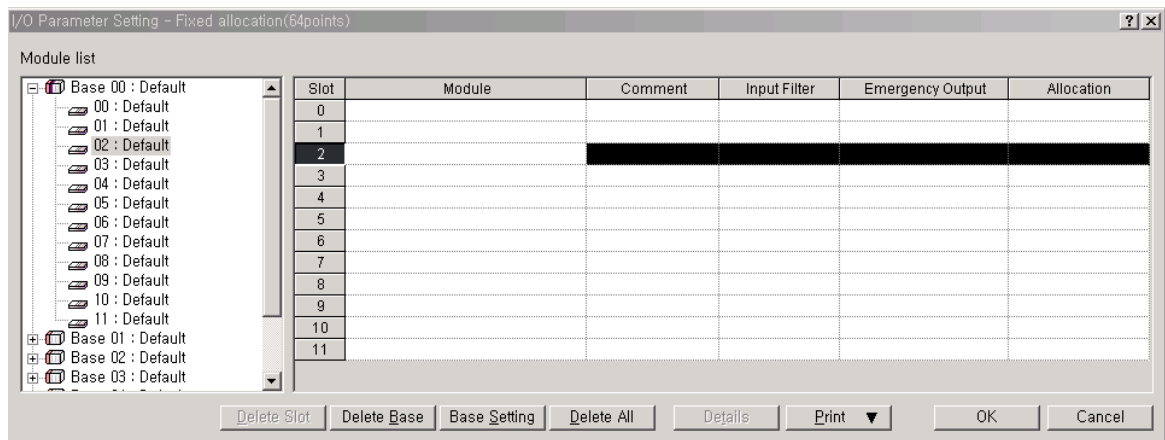

(d) Click the arrow button on the screen to display the screen where an applicable module can be selected. Search for the applicable module to select.

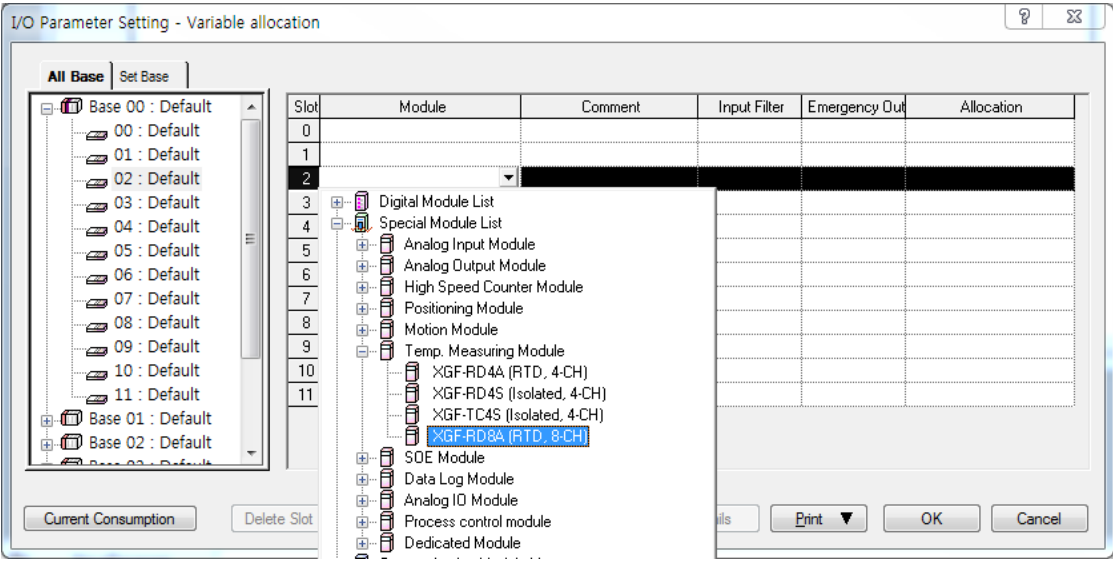

(e) After the module selected, click [Details].

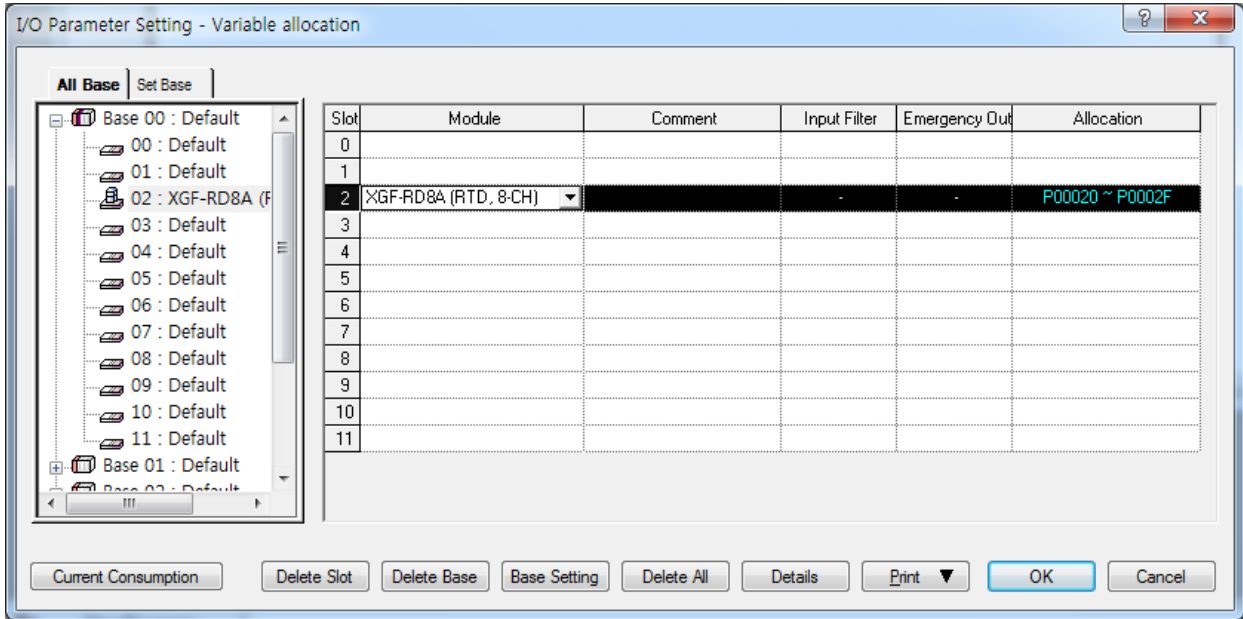

- (f) A screen will be displayed to specify parameters for respective channels as shown below. Click a desired item to display parameters to set for respective items.

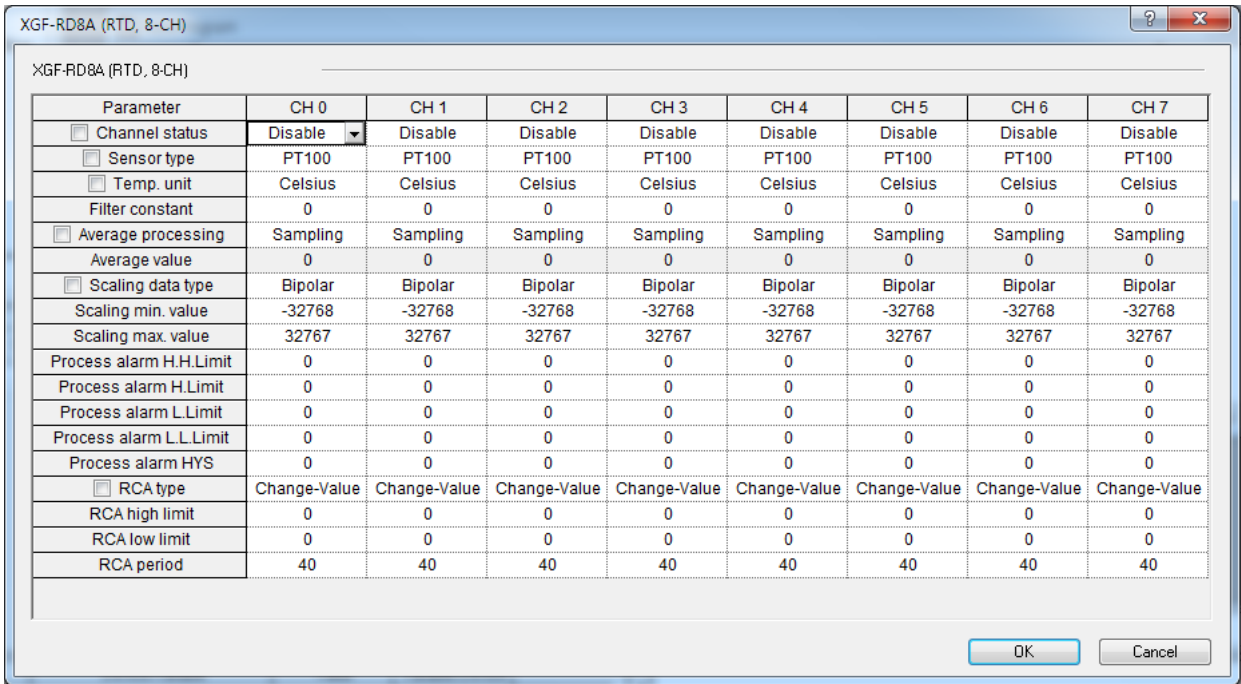

- 1) Channel status: Select Enable or Disable. Channel to operate is to be 'Enable'.

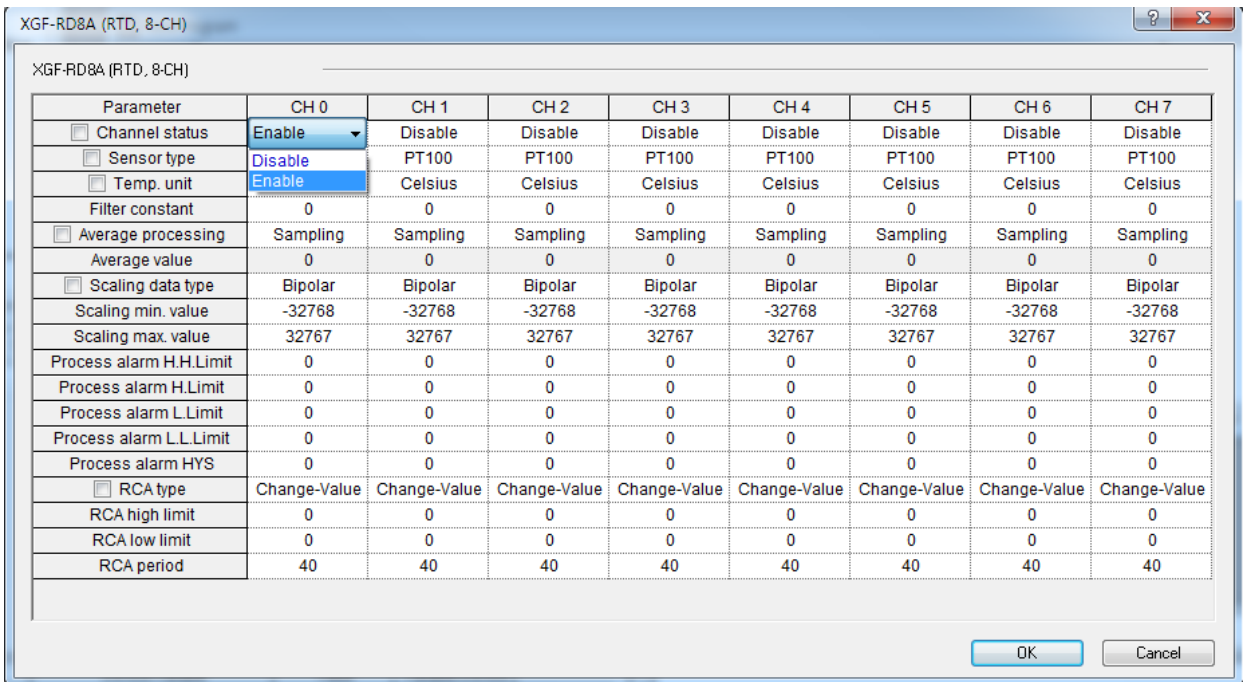

2) Sensor type: Select a sensor type to use RTD sensor.

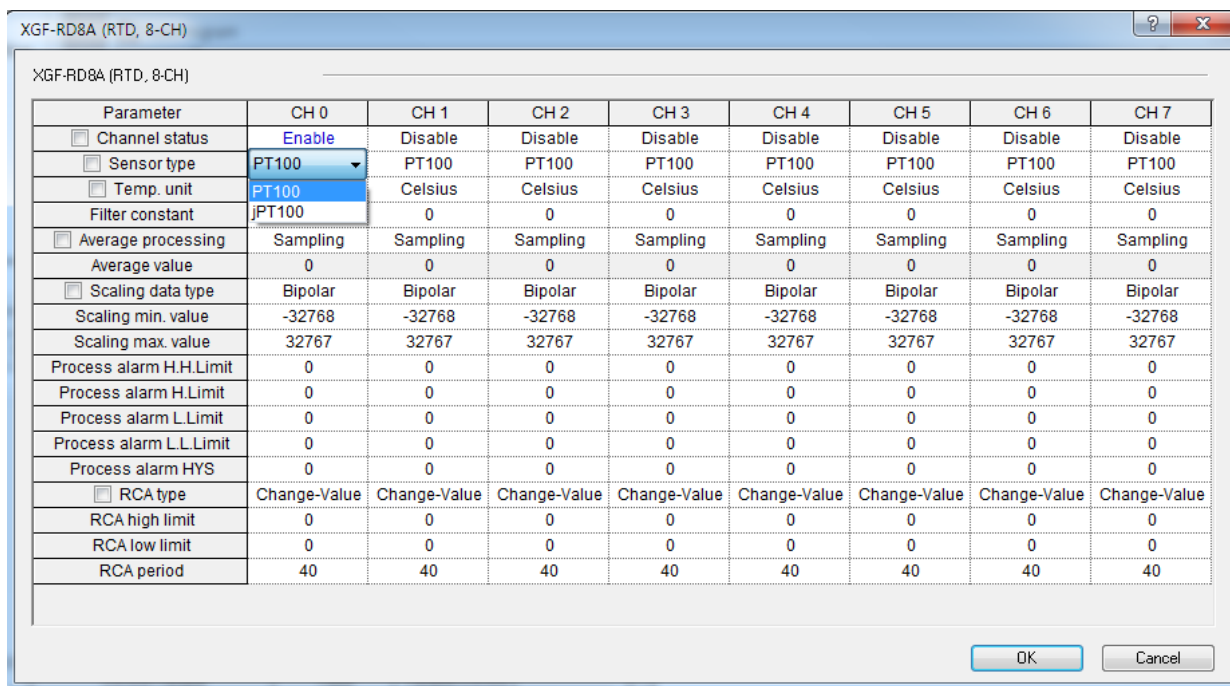

3) Temperature unit: Select the output temperature unit among Celsius and Fahrenheit.

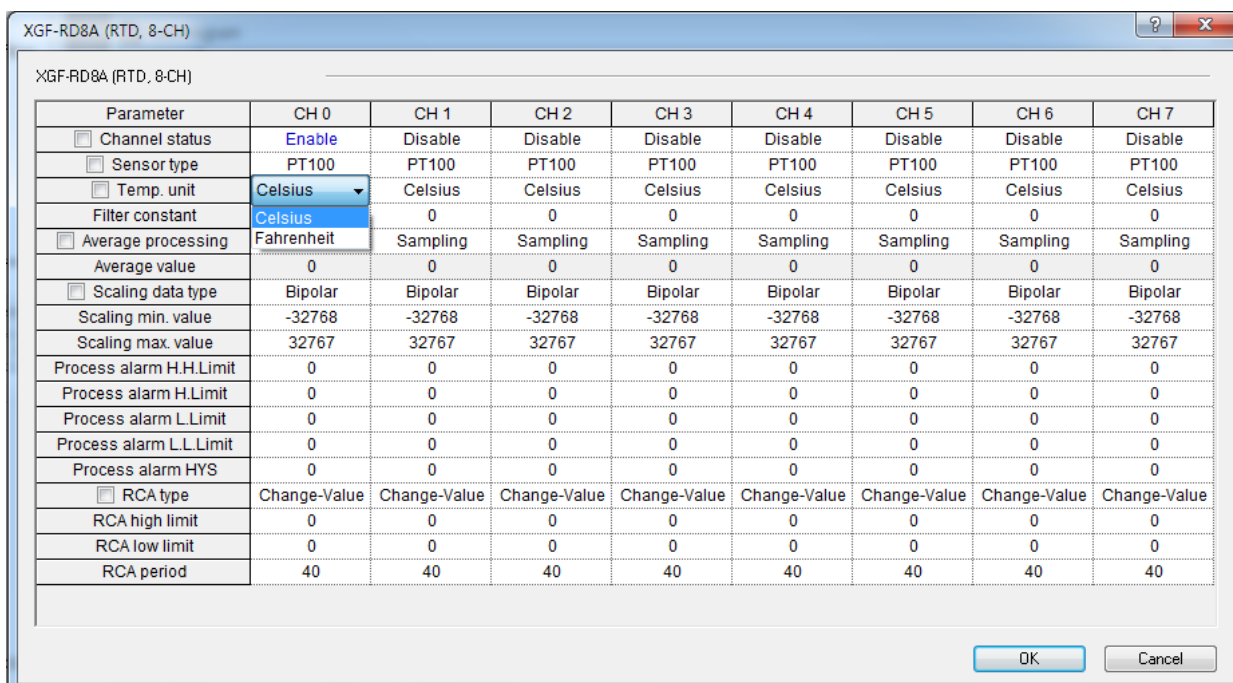

- 4) Setting value input: If an input item is selected, the input range of the applicable setting value will be displayed at the bottom of the window.

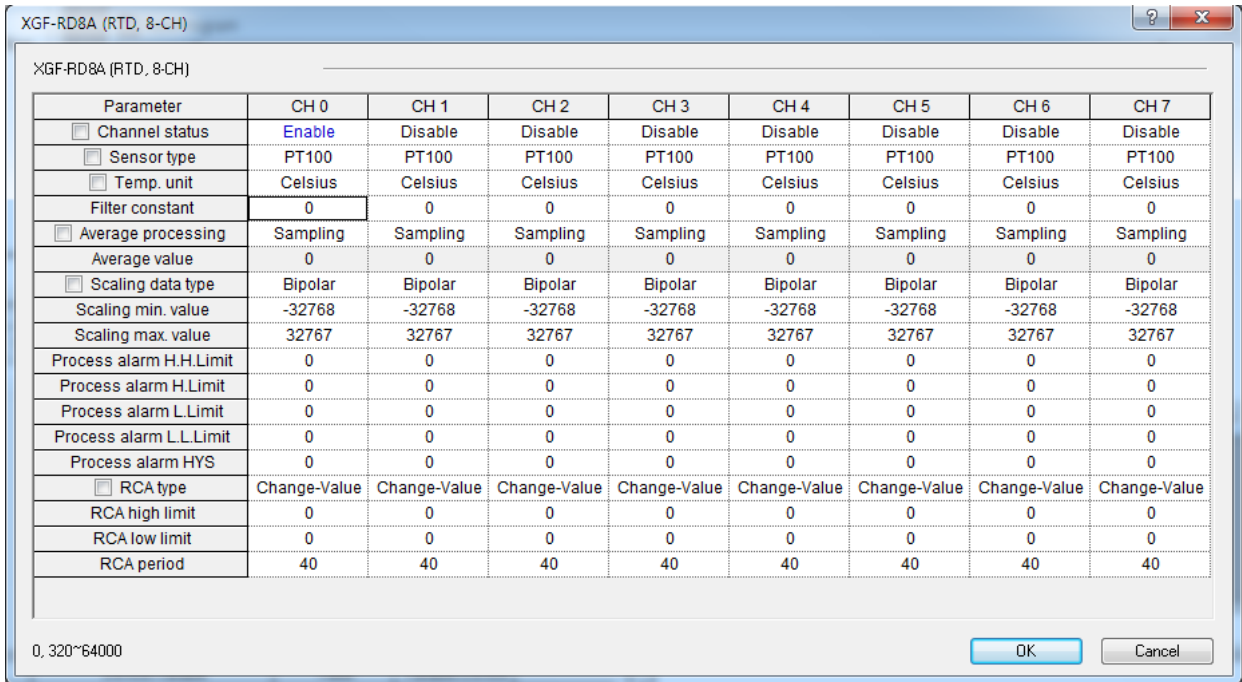

- 5) Incorrect setting: If any incorrect value is input, it will be turned red as shown below; (if input range is incorrect)

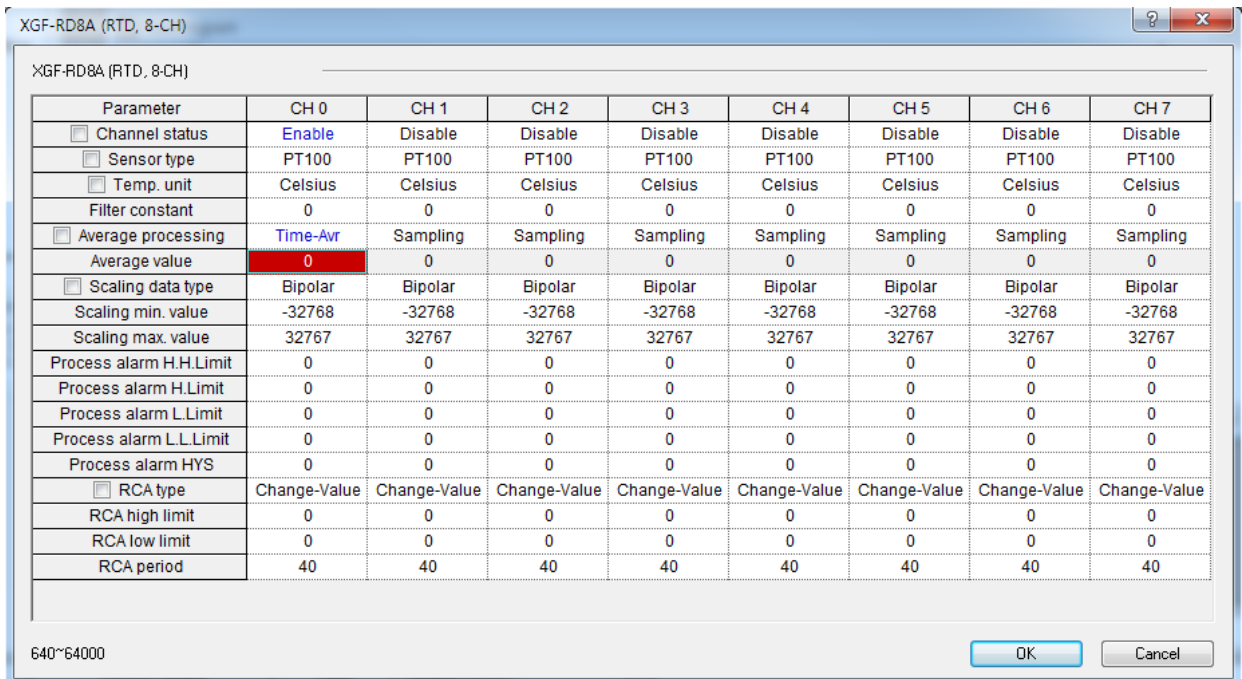

6) Applying identical settings to all channels

Check the check box on the parameter menu to select and change setting of a channel then the setting value of all the channels will be identical to changed setting value. Blow figure shows an example with this function that channel status is changed to 'Enable' of all the channels.

Parameter	CH 0	CH 1	CH 2	CH 3	CH 4	CH 5	CH 6	CH 7
<input checked="" type="checkbox"/> Channel status	Enable	Enable	Enable	Enable	Enable	Enable	Enable	Enable
<input type="checkbox"/> Sensor type	PT100	PT100	PT100	PT100	PT100	PT100	PT100	PT100
<input type="checkbox"/> Temp. unit	Celsius	Celsius	Celsius	Celsius	Celsius	Celsius	Celsius	Celsius
Filter constant	0	0	0	0	0	0	0	0
<input type="checkbox"/> Average processing	Time-Avr	Sampling	Sampling	Sampling	Sampling	Sampling	Sampling	Sampling
Average value	0	0	0	0	0	0	0	0
<input type="checkbox"/> Scaling data type	Bipolar	Bipolar	Bipolar	Bipolar	Bipolar	Bipolar	Bipolar	Bipolar
Scaling min. value	-32768	-32768	-32768	-32768	-32768	-32768	-32768	-32768
Scaling max. value	32767	32767	32767	32767	32767	32767	32767	32767
Process alarm H.H.Limit	0	0	0	0	0	0	0	0
Process alarm H.Limit	0	0	0	0	0	0	0	0
Process alarm L.Limit	0	0	0	0	0	0	0	0
Process alarm L.L.Limit	0	0	0	0	0	0	0	0
Process alarm HYS	0	0	0	0	0	0	0	0
<input type="checkbox"/> RCA type	Change-Value	Change-Value	Change-Value	Change-Value	Change-Value	Change-Value	Change-Value	Change-Value
RCA high limit	0	0	0	0	0	0	0	0
RCA low limit	0	0	0	0	0	0	0	0
RCA period	40	40	40	40	40	40	40	40

4.2.3 Functions of Special Module Monitoring

Functions of Special Module Monitoring are as described below in table 4.4.
 Following explanation is basis on XGF-RD8A module

[Table 4. 4] Functions of Special Module Monitoring

Item	Details	Remarks
[Special Module Monitoring]	(1) Monitor/Test Through applicable XG5000 menu of [Monitor] -> [Special Module Monitoring], temperature-converted value can be monitored and the operation of RTD module can be tested. (2) Monitoring the max./min. value The max./min. value of the channel can be monitored during Run. However, the max./min. value displayed here is based on the present value shown on the screen. Accordingly, when [Monitoring/Test] screen is closed, the max./min. value will not be saved.	

Notes

The screen may not be normally displayed due to insufficient system resource. In such a case, close the screen and finish other applications and restart XG5000.

4.2.4 Precautions

- The parameters specified to test RTD module on the “Special Module Monitoring” screen will be deleted when “Special Module Monitoring” screen is closed. In other words, the parameters of RTD module specified on the “Special Module Monitoring” screen will not be saved in [I/O parameters] located on the left tap of XG5000.

The screenshot shows the 'Special Module Monitor' window for an XGF-RD8A (RTD, 8-CH) module. It contains two tables. The top table lists parameters for channels CH0 through CH7, with all values set to 0. The bottom table shows detailed settings for CH0, with 'Setting value' and 'Current value' columns. A callout box points to the 'Current value' column, indicating that these values are not saved in the I/O parameters.

Item	CH0	CH1	CH2	CH3
Temperature value	0	0	0	0
Scaling value	0	0	0	0
Min. temp value	0	0	0	0
Max. temp value	0	0	0	0
Input change(value/rate)	0	0	0	0
Item	CH4	CH5	CH6	CH7
Temperature value	0	0	0	0
Scaling value	0	0	0	0
Min. temp value	0	0	0	0
Max. temp value	0	0	0	0
Input change(value/rate)	0	0	0	0

Item	Setting value	Current value
Channel		CH 0
Channel status	Disable	Disable
Sensor type	PT100	PT100
Temp. unit	Celsius	Celsius
Filter constant	0	0
Average processing	Sampling	Sampling
Average value	0	0
Scaling data type	Bipolar	Bipolar
Scaling min. value	-32768	-32768
Scaling max. value	32767	32767
Process alarm H.H.Limit	0	0
Process alarm H.Limit	0	0
Process alarm L.Limit	0	0
Process alarm L.Limit	0	0
Process alarm HYS	0	0
RCA type	Change-Value	Change-Value
RCA high limit	0	0
RCA low limit	0	0
RCA period	40	40

Not saved in [I/O parameters].

- Test function of [Special Module Monitoring] operates with the sequence program stopped and not available during run.
- Test function of [Special Module Monitoring] is provided for user to check without sequence programming if the RTD module operates normally. If RTD module is to be used for other purposes than test, use parameters setting function in [I/O parameters].

4.2.5 Special Module Monitoring

How to use Special Module Monitoring will be described below.
This is described based on XGF-RD8A.

(1) Run [Special Module Monitoring]

Run Special Module Monitoring by selecting [On-Line] -> [Connect] and [Monitor] -> [Special Module Monitoring]. If the status is not [On-Line], [Special Module Monitoring] menu will not be activated.

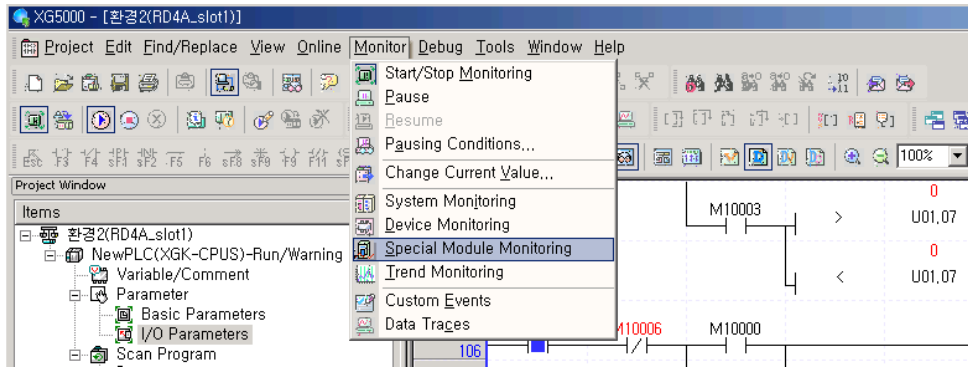

(2) How to use [Special Module Monitoring]

(a) With XG5000 connected to PLC CPU (on-line status), click [Monitor] -> [Special Module Monitoring] to display 'Special Module List' screen described in [Fig. 4.9] showing base/slot information in addition to special module type. The module installed on the present PLC system will be displayed on the list of dialog box.

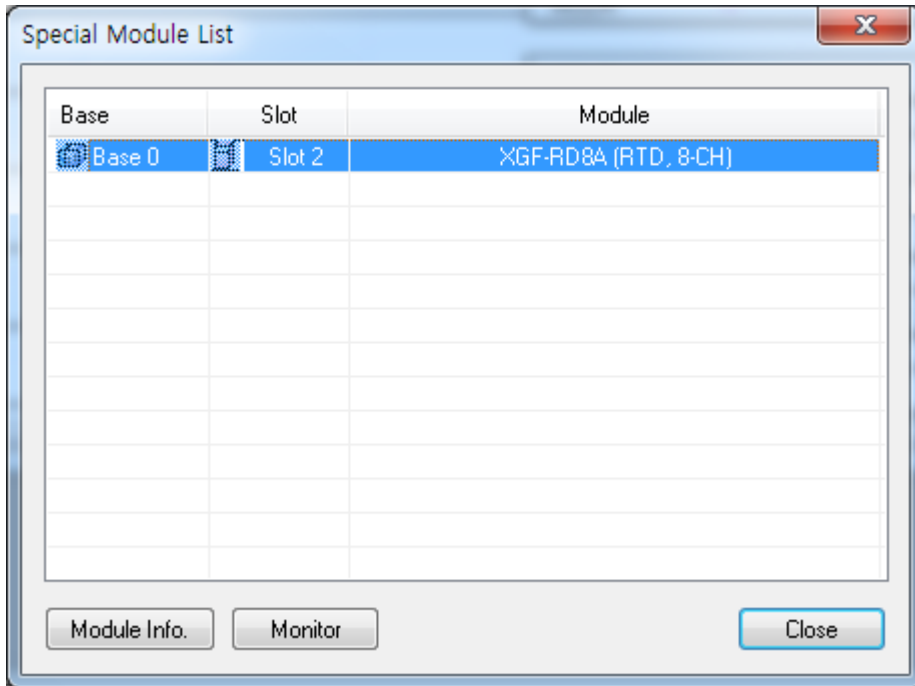

[Fig. 4. 9] Screen of [Special Module List]

- (b) Select Special Module in [Fig. 4.9] and click [Module Info.] to display the information as in [Fig. 4.10].

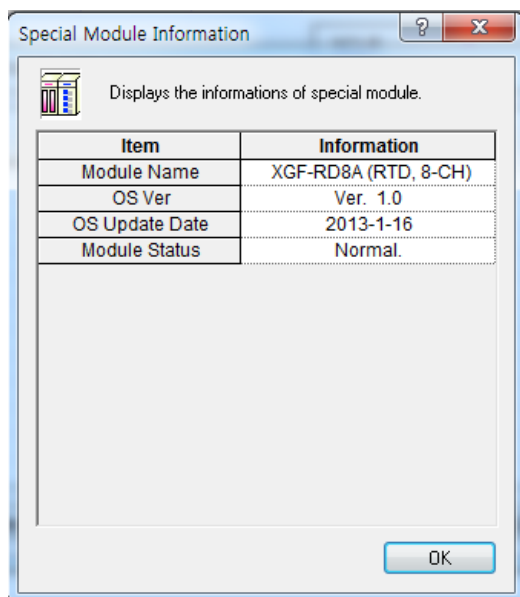

[Fig. 4.102] Screen of [Module Information]

- (c) Click [Monitor] on the “Special Module List” screen in Fig. 4.9 to display [Special Module Monitor] screen as in Fig. 4.11, where 4 options are available such as [FLAG Monitor], [Start Monitoring], [Test] and [Close]. RTD module’s temperature-converted value and scaling value are displayed on the monitor screen at the top of the screen, and parameters items of respective modules are displayed for individual setting on the test screen at the bottom of the screen.

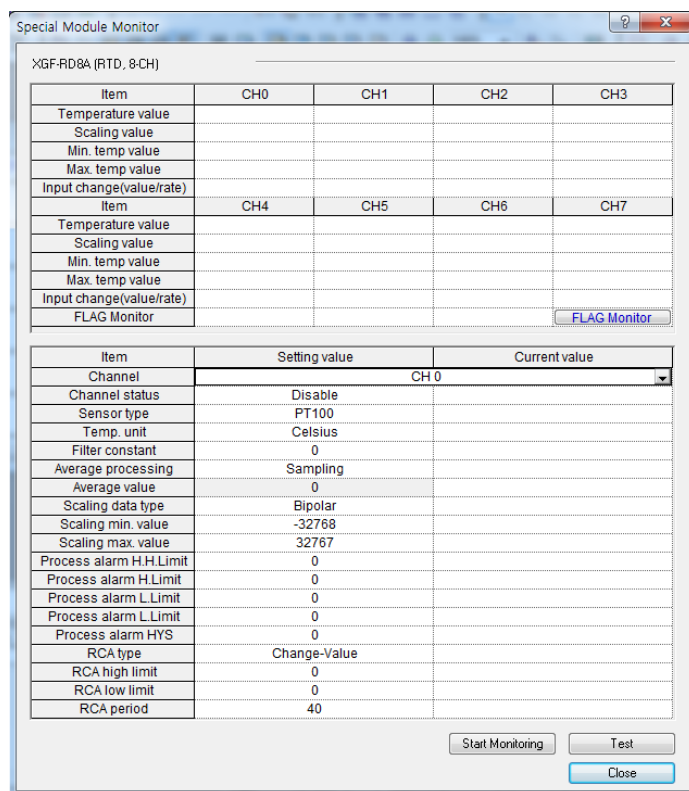

[Fig. 4.11] Screen of [Special Module Monitoring]

- (d) [Start Monitoring]: Click [Start Monitoring] to display temperature-converted value of the presently operated channel. [Fig. 4.12] is the monitoring screen displayed when the whole channels are in Stop status. In the present value field at the screen bottom, presently specified parameters of RTD module are displayed.

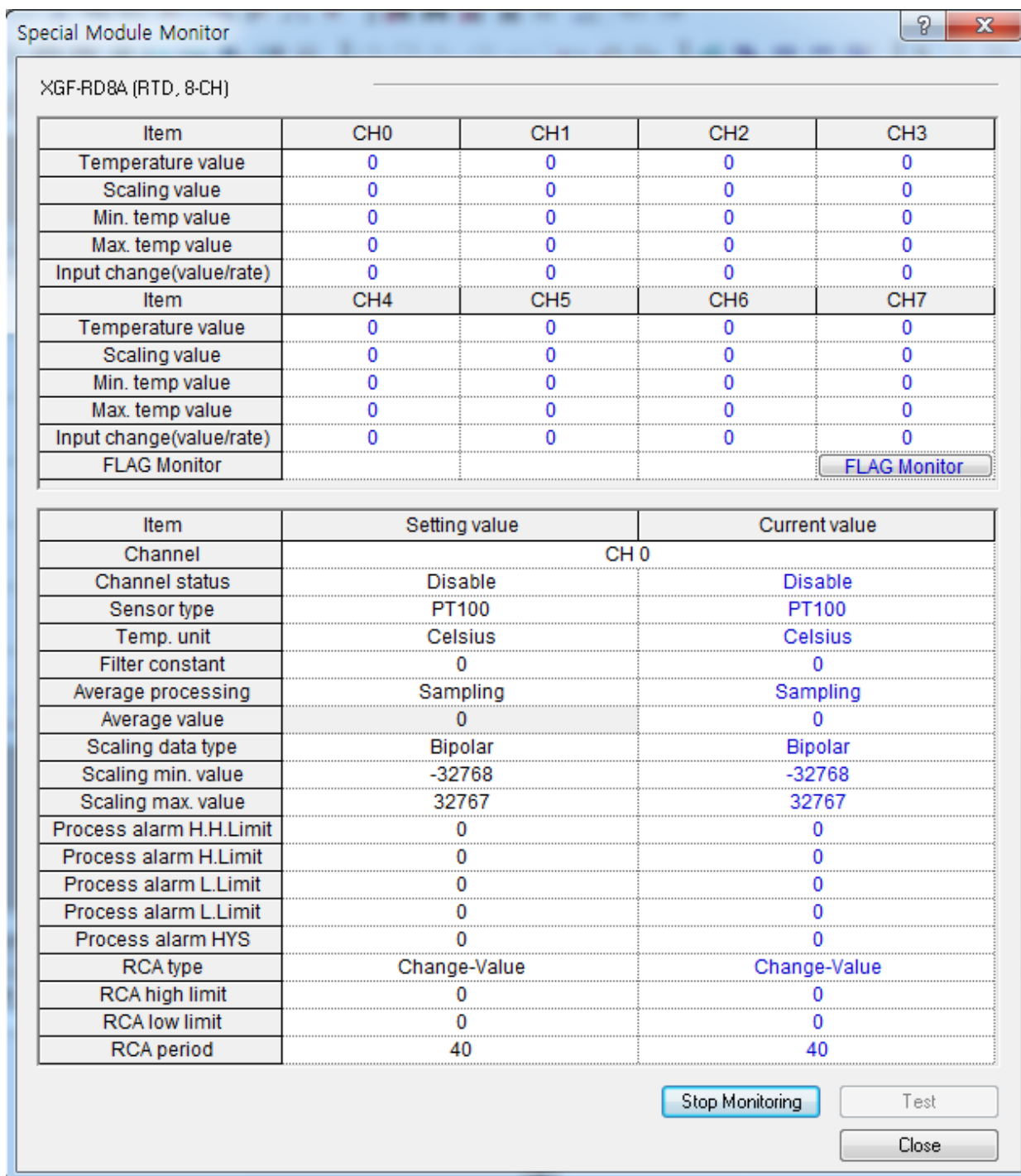

[Fig. 4.12] Execution screen of [Start Monitoring]

(e) [Test]: [Test] is used to change the presently specified parameters of RTD module. Click the setting value at the bottom field of the screen to change parameters. [Fig. 4.13] will be displayed after [Test] is executed with channel 1's input sensor type changed to PT100 in the state of input not wired.

Special Module Monitor

XGF-RD8A (RTD, 8-CH)

Item	CH0	CH1	CH2	CH3
Temperature value	0	0	0	0
Scaling value	0	0	0	0
Min. temp value	0	0	0	0
Max. temp value	0	0	0	0
Input change(value/rate)	0	0	0	0
Item	CH4	CH5	CH6	CH7
Temperature value	0	0	-2100	0
Scaling value	0	0	-32768	0
Min. temp value	0	0	0	0
Max. temp value	0	0	0	0
Input change(value/rate)	0	0	0	0

FLAG Monitor

Item	Setting value	Current value
Channel	CH 0	
Channel status	Disable	Disable
Sensor type	PT100	PT100
Temp. unit	Celsius	Celsius
Filter constant	0	0
Average processing	Sampling	Sampling
Average value	0	0
Scaling data type	Bipolar	Bipolar
Scaling min. value	-32768	-32768
Scaling max. value	32767	32767
Process alarm H.H.Limit	0	0
Process alarm H.Limit	0	0
Process alarm L.Limit	0	0
Process alarm L.Limit	0	0
Process alarm HYS	0	0
RCA type	Change-Value	Change-Value
RCA high limit	0	0
RCA low limit	0	0
RCA period	40	40

Stop Monitoring Test Close

[Fig. 4.13] Execution screen of [Test]

(f) [Max/Min active]: Click 'FLAG Monitor' on the upper screen to set [Max/Min active] of the RTD module Enabled and close the command screen to monitor the max./min. temperature-converted value as shown below;

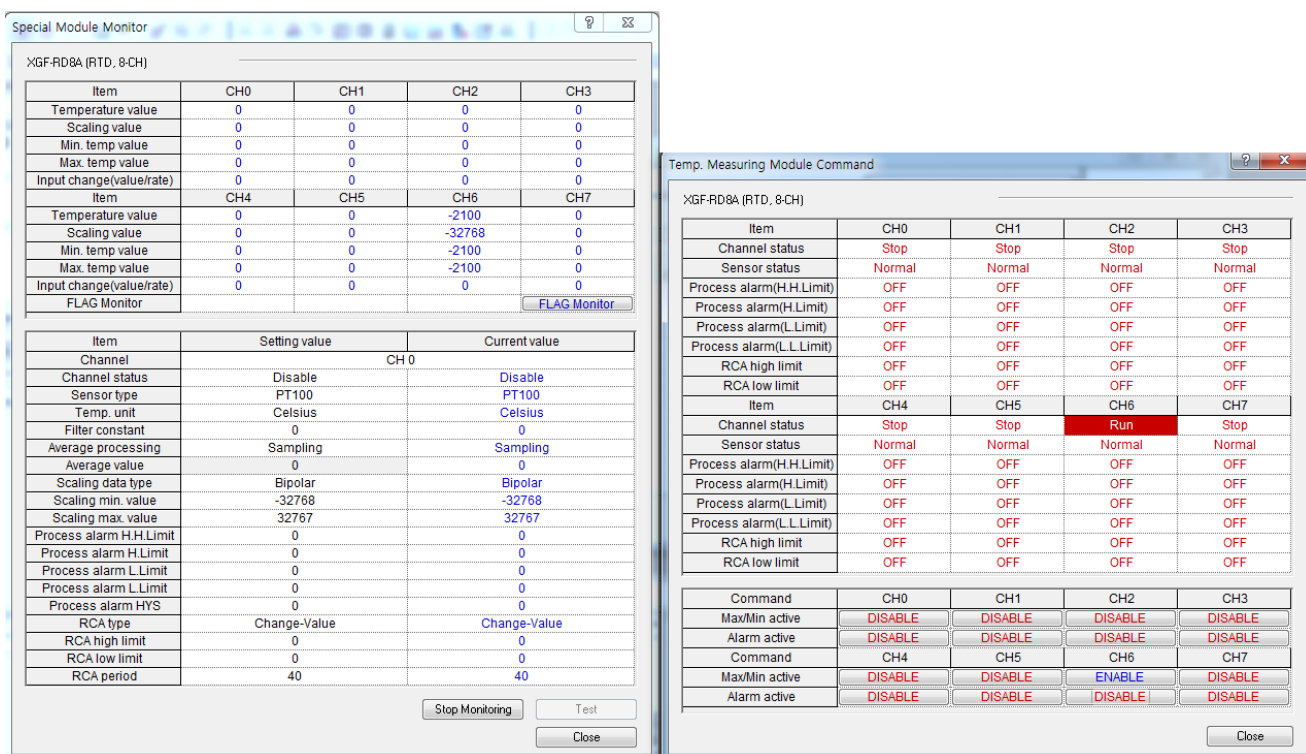

[Fig. 4. 14] Execution screen of [Search for max./min. value]

(g) [Close]: [Close] is used to escape from the monitoring/test. When the monitoring/test screen is closed, the max. value, the min. value and the present value will not be saved any more.

4.2.6 Automatic Registration of U Device

Automatic registration function of XG5000 U device is described below.

(1) Automatic registration of U device

See the special module information specified in [I/O parameters] to register the variable of each module automatically. User can modify the variables and descriptions.

[Sequence]

(a) Specify the special module of the slot on [I/O parameters].

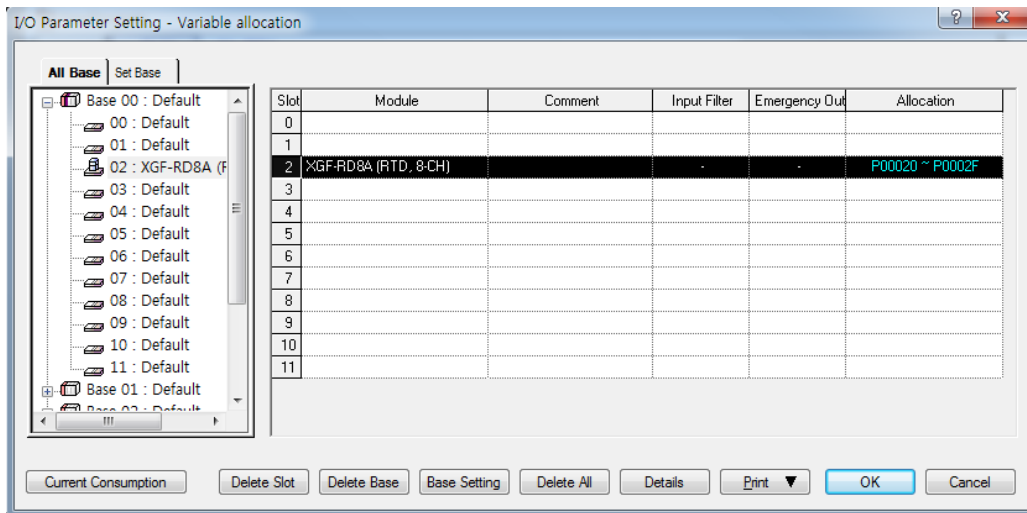

(b) Double-click [Variable/Comment].

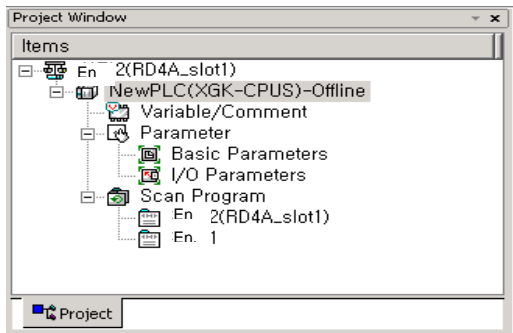

(c) Select 'Register U device' on the 'Edit' menu.

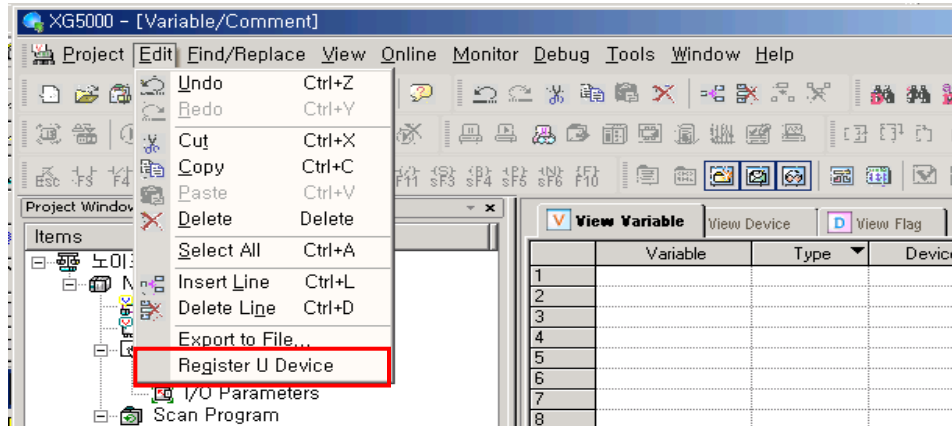

(d) Click 'Yes'.

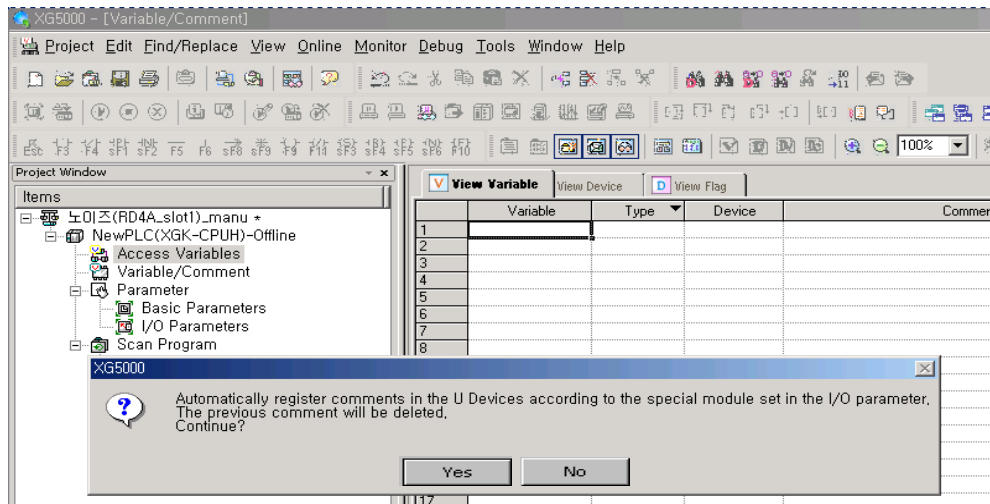

(e) Variables will be registered as shown below on the screen.

	Variable	Type	Device	Used	Comment
1	_02_CH0_ADJERR	BIT	U02.00.0	<input type="checkbox"/>	RTD Input Module: CH0 Offset/Gain Error
2	_02_CH1_ADJERR	BIT	U02.00.1	<input type="checkbox"/>	RTD Input Module: CH1 Offset/Gain Error
3	_02_CH2_ADJERR	BIT	U02.00.2	<input type="checkbox"/>	RTD Input Module: CH2 Offset/Gain Error
4	_02_CH3_ADJERR	BIT	U02.00.3	<input type="checkbox"/>	RTD Input Module: CH3 Offset/Gain Error
5	_02_CH4_ADJERR	BIT	U02.00.4	<input type="checkbox"/>	RTD Input Module: CH4 Offset/Gain Error
6	_02_CH5_ADJERR	BIT	U02.00.5	<input type="checkbox"/>	RTD Input Module: CH5 Offset/Gain Error
7	_02_CH6_ADJERR	BIT	U02.00.6	<input type="checkbox"/>	RTD Input Module: CH6 Offset/Gain Error
8	_02_CH7_ADJERR	BIT	U02.00.7	<input type="checkbox"/>	RTD Input Module: CH7 Offset/Gain Error
9	_02_EEPROMERR	BIT	U02.00.D	<input type="checkbox"/>	RTD Input Module: Offset/Gain Backup Error
10	_02_WDT_ERR	BIT	U02.00.E	<input type="checkbox"/>	RTD Input Module: Module H/W Error
11	_02_RDY	BIT	U02.00.F	<input type="checkbox"/>	RTD Input Module: Module Ready
12	_02_CH0_ACT	BIT	U02.01.0	<input type="checkbox"/>	RTD Input Module: CH0 Running
13	_02_CH1_ACT	BIT	U02.01.1	<input type="checkbox"/>	RTD Input Module: CH1 Running
14	_02_CH2_ACT	BIT	U02.01.2	<input type="checkbox"/>	RTD Input Module: CH2 Running
15	_02_CH3_ACT	BIT	U02.01.3	<input type="checkbox"/>	RTD Input Module: CH3 Running
16	_02_CH4_ACT	BIT	U02.01.4	<input type="checkbox"/>	RTD Input Module: CH4 Running
17	_02_CH5_ACT	BIT	U02.01.5	<input type="checkbox"/>	RTD Input Module: CH5 Running
18	_02_CH6_ACT	BIT	U02.01.6	<input type="checkbox"/>	RTD Input Module: CH6 Running
19	_02_CH7_ACT	BIT	U02.01.7	<input type="checkbox"/>	RTD Input Module: CH7 Running
20	_02_CH0_BOUT	BIT	U02.01.8	<input type="checkbox"/>	RTD Input Module: CH0 Input Disconnection
21	_02_CH1_BOUT	BIT	U02.01.9	<input type="checkbox"/>	RTD Input Module: CH1 Input Disconnection
22	_02_CH2_BOUT	BIT	U02.01.A	<input type="checkbox"/>	RTD Input Module: CH2 Input Disconnection
23	_02_CH3_BOUT	BIT	U02.01.B	<input type="checkbox"/>	RTD Input Module: CH3 Input Disconnection

(2) Save variables

- (a) Contents in the 'View variables' tap can be saved in a text file.
- (b) Click 'Save in a text file' on the 'Edit' menu.
- (c) Contents in the 'View variables' tap will be saved in a text file..

(3) View variables in the program

(a) Example program of XG5000 is as shown below;

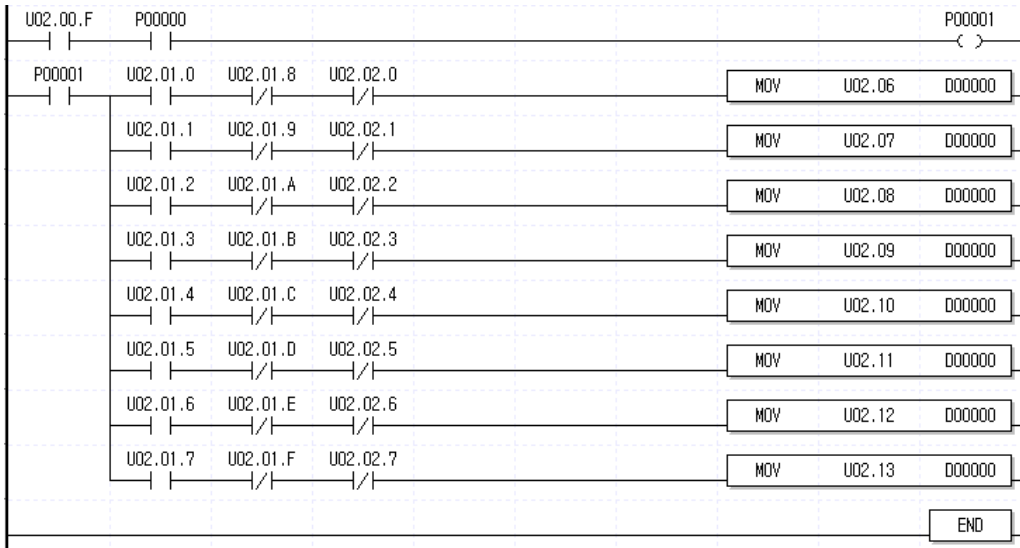

(b) Click 'View variables' on the tap menu of 'View'. Devices will be changed to variables.

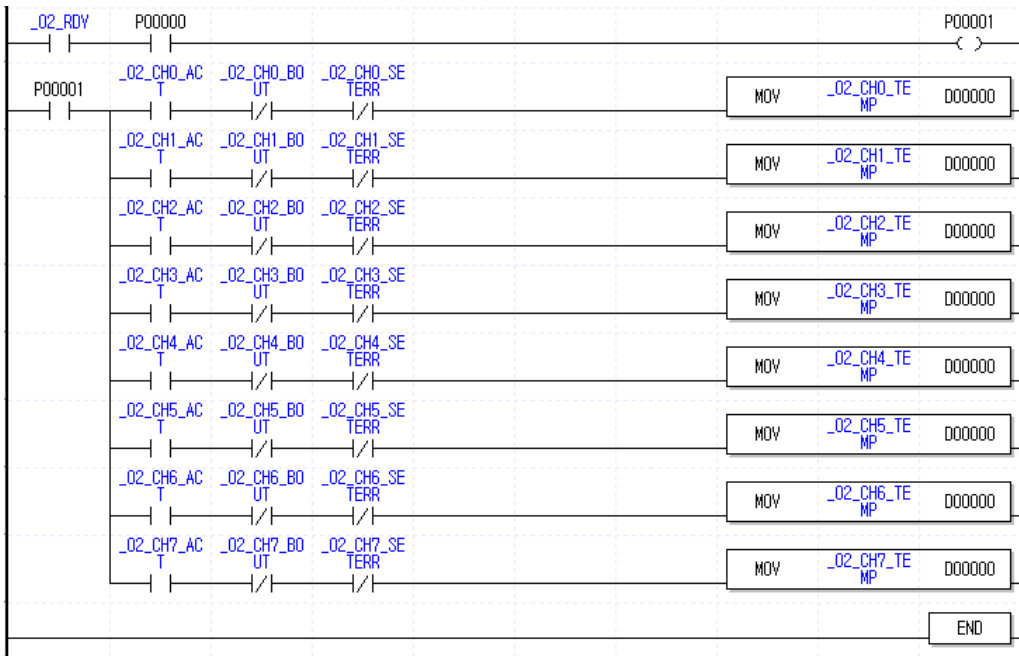

(c) Click 'Devices/Variables' on the menu of 'View' to see devices and variables at a time.

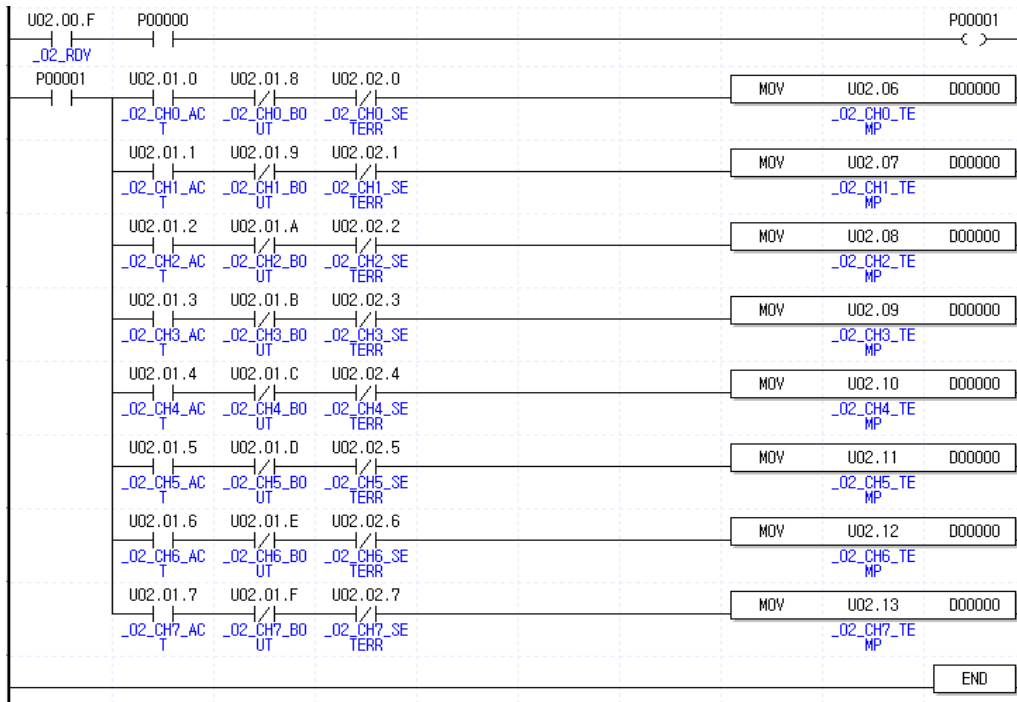

(d) Click 'Devices/Comments' on the menu of 'View' to see devices and descriptions at a time.

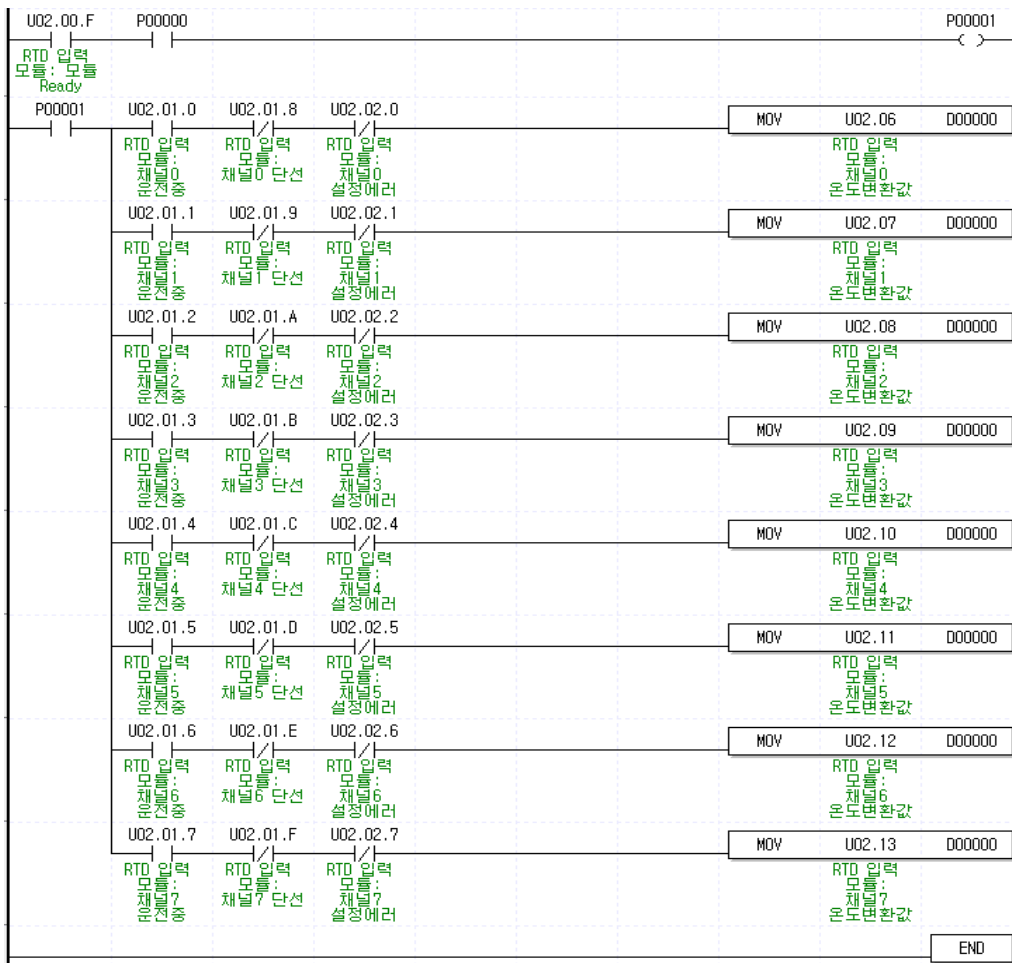

Chapter 5 Internal Memory Configuration and Function (For XGK)

The RTD input module has internal memories for data communications with PLC CPU.

5.1 XGF-RD4A/XGF-RD4S Modules

Explain configuration of internal memories.

5.1.1 Internal Memory Configuration

(1) Input/Output area of conversion data (U Device)

Table 5.1 shows the conversion data input/output area of the RTD module.

[Table 5. 1] Conversion data input/output area

Device Assignment	Description	R/W	Signal Direction
UXY.00.0 UXY.00.1 UXY.00.2 UXY.00.3 UXY.00.D Uxy.00.E Uxy.00.F	Channel 0 Off/Gain Adjust Error Channel 1 Off/Gain Adjust Error Channel 2 Off/Gain Adjust Error Channel 3 Off/Gain Adjust Error Module Off/Gain Backup Error Module Hardware Error Ready	R	RTD input → CPU
UXY.01.0 UXY.01.1 UXY.01.2 UXY.01.3 UXY.01.4 UXY.01.5 UXY.01.6 UXY.01.7 UXY.01.8 UXY.01.9 UXY.01.A UXY.01.B	Channel 0 Operation Flag Channel 1 Operation Flag Channel 2 Operation Flag Channel 3 Operation Flag Channel 0 Disconnection Flag Channel 1 Disconnection Flag Channel 2 Disconnection Flag Channel 3 Disconnection Flag Channel 0 Setting Error Channel 1 Setting Error Channel 2 Setting Error Channel 3 Setting Error	R	RTD input → CPU
UXY.02.0 UXY.02.1 UXY.02.2 UXY.02.3 UXY.02.4 UXY.02.5 UXY.02.6 UXY.02.7 UXY.02.8 UXY.02.9 UXY.02.A UXY.02.B UXY.02.C UXY.02.D UXY.02.E UXY.02.F	Channel 0 Process Alarm Low-Low Limit Flag Channel 0 Process Alarm Low Limit Flag Channel 0 Process Alarm High Limit Flag Channel 0 Process Alarm High-High Limit Flag Channel 1 Process Alarm Low-Low Limit Flag Channel 1 Process Alarm Low Limit Flag Channel 1 Process Alarm High Limit Flag Channel 1 Process Alarm High-High Limit Flag Channel 2 Process Alarm Low-Low Limit Flag Channel 2 Process Alarm Low Limit Flag Channel 2 Process Alarm High Limit Flag Channel 2 Process Alarm High-High Limit Flag Channel 3 Process Alarm Low-Low Limit Flag Channel 3 Process Alarm Low Limit Flag Channel 3 Process Alarm High Limit Flag Channel 3 Process Alarm High-High Limit Flag	R	RTD input → CPU
UXY.03.0 UXY.03.1 UXY.03.4 UXY.03.5 UXY.03.8 UXY.03.9 UXY.03.C UXY.03.D	Channel 0 Input Variation Alarm Lower Limit Flag Channel 0 Input Variation Alarm Upper Limit Flag Channel 1 Input Variation Alarm Lower Limit Flag Channel 1 Input Variation Alarm Upper Limit Flag Channel 2 Input Variation Alarm Lower Limit Flag Channel 2 Input Variation Alarm Upper Limit Flag Channel 3 Input Variation Alarm Lower Limit Flag Channel 3 Input Variation Alarm Upper Limit Flag	R	RTD input → CPU

Chapter5 Internal Memory Configuration and Function (For XGK)

Device Assignment	Description	R/W	Signal Direction	
UXY.04	Channel 0 Temperature-converted value	R	RTD input → CPU	
UXY.05	Channel 1 Temperature-converted value	R		
UXY.06	Channel 2 Temperature-converted value	R		
UXY.07	Channel 3 Temperature-converted value	R		
UXY.08	Channel 0 Scaled value	R		
UXY.09	Channel 1 Scaled value	R		
UXY.10	Channel 2 Scaled value	R		
UXY.11	Channel 3 Scaled value	R		
UXY.12	Channel 0 Measured Temperature Min. Value	R		
UXY.13	Channel 0 Measured Temperature Max. Value	R		
UXY.14	Channel 1 Measured Temperature Min. Value	R		
UXY.15	Channel 1 Measured Temperature Max. Value	R		
UXY.16	Channel 2 Measured Temperature Min. Value	R		
UXY.17	Channel 2 Measured Temperature Max. Value	R		
UXY.18	Channel 3 Measured Temperature Min. Value	R		
UXY.19	Channel 3 Measured Temperature Max. Value	R		
UXY.20	Channel 0 Data Uploading Time	R		RTD input → CPU
UXY.21				
UXY.22	Channel 1 Data Uploading Time	R		
UXY.23				
UXY.24	Channel 2 Data Uploading Time	R		
UXY.25				
UXY.26	Channel 3 Data Uploading Time	R		
UXY.27				

[Table 5.2] Command delivered from XGK PLC to module (XGK PLC output area)

Device Assignment	Description	R/W	Signal Direction
UXY.29.0	Channel 0 Max./Min. Value Detecting Function Command	R/W	RTD input ↔ CPU
UXY.29.1	Channel 1 Max./Min. Value Detecting Function Command		
UXY.29.2	Channel 2 Max./Min. Value Detecting Function Command		
UXY.29.3	Channel 3 Max./Min. Value Detecting Function Command		
UXY.29.4	Channel 0 Alarm (PVA/RCA) Function Command		
UXY.29.5	Channel 1 Alarm (PVA/RCA) Function Command		
UXY.29.6	Channel 2 Alarm (PVA/RCA) Function Command		
UXY.29.7	Channel 3 Alarm (PVA/RCA) Function Command		

- (a) In the device assigned, X stands for the Base No. and Y for the Slot No. on which module is installed.
- (b) In order to read 'CH0 temperature-converted value' of RTD input installed on Base No.0, Slot No.4, its address be U04.04.

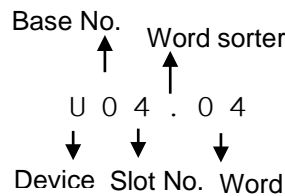

- (c) In order to read 'Flag to detect CH3 disconnection' of RTD module installed on Base No.0, Slot No.5, its address shall be U05.1.7.
 (In case that RTD module installed on Slot No.10, its address shall be U0A.1.7)

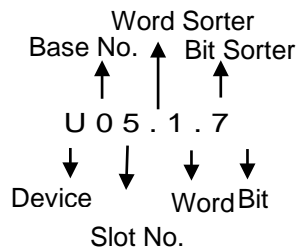

(2) Operation parameter setting area (PUT/GET)

Table 5.3 shows the operation parameter setting area of the XGF-RD4A/RD4S module.

Address		Description	Default	R/W	Remark
Hex.	Dec.				
0H	0	Using Channel Setting	0	R/W	PUT/ GET
1H	1	Channel 0 Sensor Type Setting	0	R/W	
2H	2	Channel 1 Sensor Type Setting			
3H	3	Channel 2 Sensor Type Setting			
4H	4	Channel 3 Sensor Type Setting			
5H	5	Temperature Display Unit Setting	0	R/W	
6H	6	Channel 0 Filter Value Setting	0	R/W	
7H	7	Channel 1 Filter Value Setting			
8H	8	Channel 2 Filter Value Setting			
9H	9	Channel 3 Filter Value Setting			
AH	10	Channel 0 Averaging Method Setting	0	R/W	
BH	11	Channel 1 Averaging Method Setting			
CH	12	Channel 2 Averaging Method Setting			
DH	13	Channel 3 Averaging Method Setting			
EH	14	Channel 0 Average Value Setting	0	R/W	
FH	15	Channel 1 Average Value Setting			
10H	16	Channel 2 Average Value Setting			
11H	17	Channel 3 Average Value Setting			
12H	18	Scaling Type Setting	0	R/W	
13H	19	Channel 0 Scaled Range Min. Value Setting	-32768	R/W	
14H	20	Channel 0 Scaled Range Max. Value Setting	32767		
15H	21	Channel 1 Scaled Range Min. Value Setting	-32768		
16H	22	Channel 1 Scaled Range Max. Value Setting	32767		
17H	23	Channel 2 Scaled Range Min. Value Setting	-32768		
18H	24	Channel 2 Scaled Range Max. Value Setting	32767		
19H	25	Channel 3 Scaled Range Min. Value Setting	-32768		
1AH	26	Channel 3 Scaled Range Max. Value Setting	32767		

[Table 5.3] Operation parameter setting area

Chapter 5 Internal Memory Configuration and Function (For XGK)

Address		Description	Default	R/W	Remark
Hex.	Dec.				
1BH	27	Channel 0 Process Alarm High-High Limit Setting	0	R/W	PUT/ GET
1CH	28	Channel 0 Process Alarm High Limit Setting			
1DH	29	Channel 0 Process Alarm Low Limit Setting			
1EH	30	Channel 0 Process Alarm Min. Low-Low Limit Setting			
1FH	31	Channel 1 Process Alarm High-High Limit Setting			
20H	32	Channel 1 Process Alarm High Limit Setting			
21H	33	Channel 1 Process Alarm Low Limit Setting			
22H	34	Channel 1 Process Alarm Low-Low Limit Setting			
23H	35	Channel 2 Process Alarm High-High Limit Setting			
24H	36	Channel 2 Process Alarm High Limit Setting			
25H	37	Channel 2 Process Alarm Low Limit Setting			
26H	38	Channel 2 Process Alarm Low-Low Limit Setting			
27H	39	Channel 3 Process Alarm High-High Limit Setting			
28H	40	Channel 3 Process Alarm High Limit Setting			
29H	41	Channel 3 Process Alarm Low Setting			
2AH	42	Channel 3 Process Alarm Low-Low Setting	0	R/W	
2BH	43	Channel 0 Process Alarm Hysteresis Setting			
2CH	44	Channel 1 Process Alarm Hysteresis Setting			
2DH	45	Channel 2 Process Alarm Hysteresis Setting			
2EH	46	Channel 3 Process Alarm Hysteresis Setting	0	R/W	
2FH	47	Input Variation Alarm Value Unit Setting			
30H	48	Channel 0 Input Variation Alarm Upper Limit Value Setting	0	R/W	
31H	49	Channel 0 Input Variation Alarm Lower Limit Value Setting			
32H	50	Channel 1 Input Variation Alarm Upper Limit Value Setting			
33H	51	Channel 1 Input Variation Alarm Lower Limit Value Setting			
34H	52	Channel 2 Input Variation Alarm Upper Limit Value Setting			
35H	53	Channel 2 Input Variation Alarm Lower Limit Value Setting			
36H	54	Channel 3 Input Variation Alarm Upper Limit Value Setting			
37H	55	Channel 3 Input Variation Alarm Lower Limit Value Setting	40	R/W	
38H	56	Channel 0 Input Variation Alarm Detection Cycle Setting			
39H	57	Channel 1 Input Variation Alarm Detection Cycle Setting			
3AH	58	Channel 2 Input Variation Alarm Detection Cycle Setting			
3BH	59	Channel 3 Input Variation Alarm Detection Cycle Setting			

(3) The other data monitoring area (GET/GETP)

Address		Description	Default	R/W	Remark
Hex.	Dec.				
3CH	60	Channel 0 Setting Error Information (Flag)	-	R	GET
3DH	61	Channel 1 Setting Error Information (Flag)			
3EH	62	Channel 2 Setting Error Information (Flag)			
3FH	63	Channel 3 Setting Error Information (Flag)			
40H	64	Channel 0 Input Variation Value (Input Variation Alarm Function Value)	-	R	
41H	65	Channel 1 Input Variation Value (Input Variation Alarm Function Value)			
42H	66	Channel 2 Input Variation Value (Input Variation Alarm Function Value)			
43H	67	Channel 3 Input Variation Value (Input Variation Alarm Function Value)			
44H	68	Channel 0 Disconnection Information (code)	-	R	
45H	69	Channel 1 Disconnection Information (code)			
46H	70	Channel 2 Disconnection Information (code)			
47H	71	Channel 3 Disconnection Information (code)			

※ R/W means Read/Write availability.

Notes

U Device: It is an internal memory of PLC CPU used to read and write the specific area of the special/communication module (data to read periodically, specified in module) in XGK, XGI, XGR PLC per scan.
Such data as converted of the special module which is always read and written is assigned to this area. Like the other devices, it can be directly used for general commands such as MOV, CMP, ADD, etc. (while PUT/GET commands need to be used for parameter area of the module.)

5.1.2 Internal Memory Functions

(1) Module READY/ERROR flag (UXY.00, X: Base No., Y: Slot No.)

- (a) UXY.00.F: It will be ON when PLC CPU is powered or reset with RTD module completely ready.
- (b) UXY.00.E: Module H/W error. If “ON”, refer to Chapter 9 Troubleshooting.
- (c) UXY.00.D: Module offset/gain memory error. Refer to Chapter 9 Troubleshooting if ON.
- (d) UXY.00.3~0: Offset/gain adjustment error of the applicable channel.
If “ON”, it means that Offset value, Gain value, or that there is disconnection when adjusted. Refer to Chapter 9 Troubleshooting

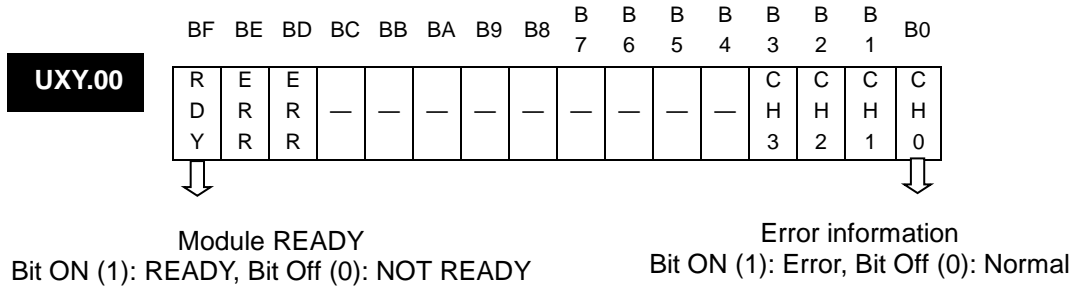

(2) 2 Run channel flag (UXY.01, X: Base No., Y: Slot No.)

Run information of respective channels is saved.

- (a) UXY.01.B~8: Setting value error of the applicable channel. If it is “1”, see information area of the setting error (addresses 60~63).
- (b) UXY.01.7~4: It displays disconnection of the applicable channel. If it is 1”, see information area of disconnection (addresses 68~71).
- (c) UXY.01.3~0: It displays run status of the applicable channel. If the applicable channel bit of “Used CH setting area (address 0)” is set to 1, it will be 1.

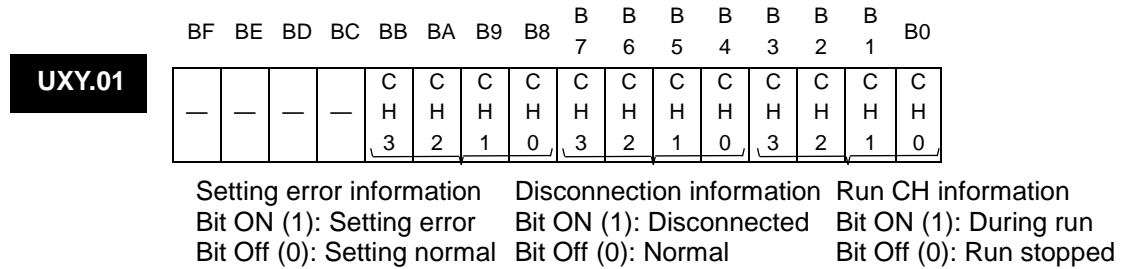

(3) Flag to output process alarm (UXY.02 , X: Base No., Y: Slot No.)

- (a)UXY.02.F~C: Flag to output process alarm of CH3 (High-High, High, Low, Low-Low)
- (b)UXY.02.B~8: Flag to output process alarm of CH2 (High-High, High, Low, Low-Low)
- (c)UXY.02.7~4: Flag to output process alarm of CH1 (High-High, High, Low, Low-Low)
- (d)UXY.02.3~0: Flag to output process alarm of CH0 (High-High, High, Low, Low-Low)

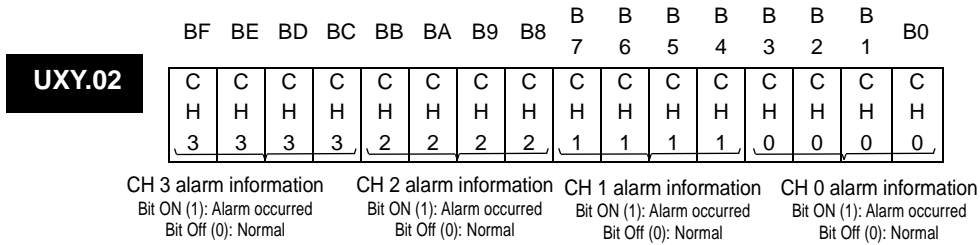

(4) Flag to output input variation alarm (UXY.03 , X: Base No., Y: Slot No.)

- (a)UXY.02.D~C: Flag to output input variation (amount/rate) alarm of CH3 (highest/lowest)
- (b)UXY.02.9~8: Flag to output input variation (amount/rate) alarm of CH2 (highest/lowest)
- (c)UXY.02.5~4: Flag to output input variation (amount/rate) alarm of CH1 (highest/lowest)
- (d)UXY.02.1~0: Flag to output input variation (amount/rate) alarm of CH0 (highest/lowest)

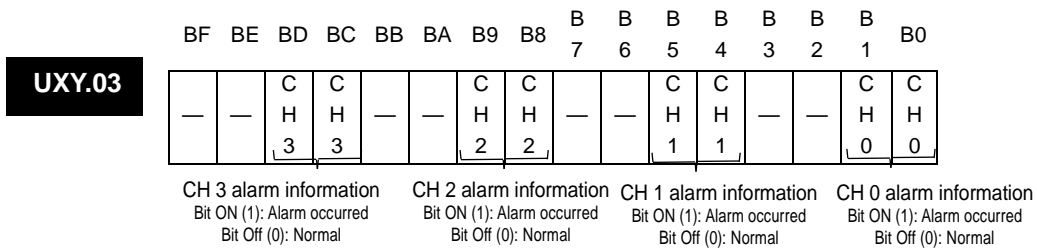

(5) Temperature-converted value (UXY.04 ~ UXY.07, X: Base No., Y: Slot No.)

- (a) Temperature-converted value of each channel is output.

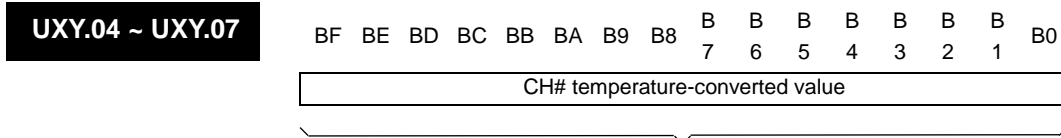

Address	Description
4	Channel 0 temperature-converted value
5	Channel 1 temperature-converted value
6	Channel 2 temperature-converted value
7	Channel 3 temperature-converted value

Output range of temperature value based on sensor type is as follows;

Sensor type	Digital output range	Effective measuring range	Reference
PT100	2100 ~ 8600 (-210.0°C ~ 860.0°C)	2000 ~ 8500 (-200.0°C ~ 850.0°C)	
JPT100	-2100 ~ 6500 (-210.0°C ~ 650.0°C)	-2100 ~ 6400 (-200.0°C ~ 640.0°C)	
PT1000	2100 ~ 8600 (-210.0°C ~ 860.0°C)	-2000 ~ 8500 (-200.0°C ~ 850.0°C)	
NT100	-700 ~ 1900 (-70.0°C ~ 190.0°C)	-600 ~ 1800 (-600.0°C ~ 1800.0°C)	

(6) Scaled calculation value (UXY.08 ~ UXY.11, X: Base No., Y: Slot No.)

- (a) Scaled calculation value of each channel is output.
- (b) Scaled calculation value is output within scale range of the max. value ~ the min. value (see operation parameters) which specifies temperature-converted value.(See Chapter 2 Specifications for details on its functions.)

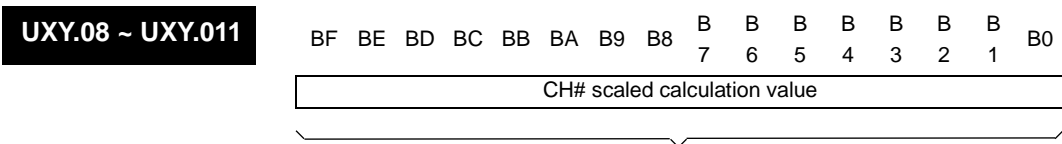

Address	Description
8	Channel 0 Scaled calculation value
9	Channel 0 Scaled calculation value
10	Channel 0 Scaled calculation value
11	Channel 0 Scaled calculation value

(7) Max/Min temperature-converted value output (UXY.12 ~ UXY.19, X: Base No., Y: Slot No.)

- (a) Max/Min temperature-converted value is output when the command to search for max/min is 1. (See Chapter 2 Specifications for details on its functions.)

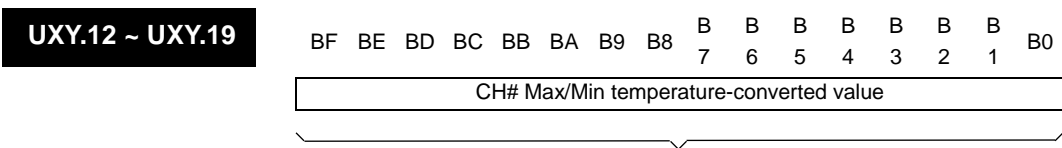

Address	Description
12	Channel 0 Measured Temperature Minimum Value
13	Channel 0 Measured Temperature Maximum Value
14	Channel 1 Measured Temperature Minimum Value
15	Channel 1 Measured Temperature Maximum Value
16	Channel 2 Measured Temperature Minimum Value
17	Channel 2 Measured Temperature Maximum Value
18	Channel 3 Measured Temperature Minimum Value
19	Channel 3 Measured Temperature Maximum Value

(8) Data uploading time (UXY.20 ~ UXY.27, X: Base No., Y: Slot No.)

- (a) It is an area to store the update interval (Time: the count of data 1 in the applicable area is 0.1ms.) when updating the module data to share the data with XGK PLC.
- (b) If temperature is controlled by XGT PLC, the data is used to decide the controlling cycle. (See Chapter 6 Programming for application example)

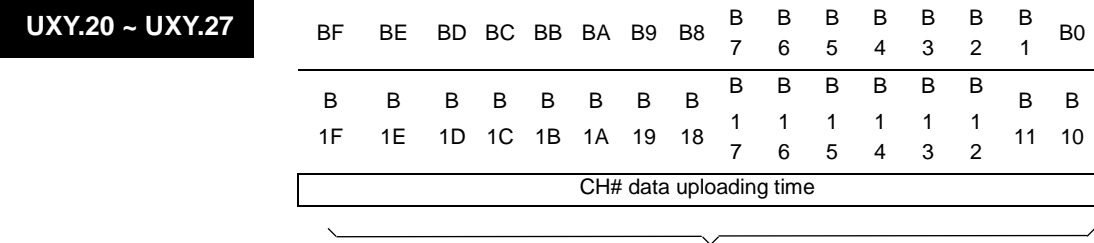

Address	Description
20	Channel 0 Data Uploading Time
21	
22	Channel 1 Data Uploading Time
23	
24	Channel 2 Data Uploading Time
25	
26	Channel 3 Data Uploading Time
27	

(9) Command bit information (UXY.29.0, X: Base No., Y: Slot No.)

- (a) Bit 7~4: Alarm function operates if the alarm output enabling bit of the applicable channel is set to 1.
- (b) Bit 3~0: Max/min value is displayed from the moment when max/min value detection enabling bit of the applicable channel is set to 1. If set to 0, max/min value will be detected no more but the value at the moment will be kept.

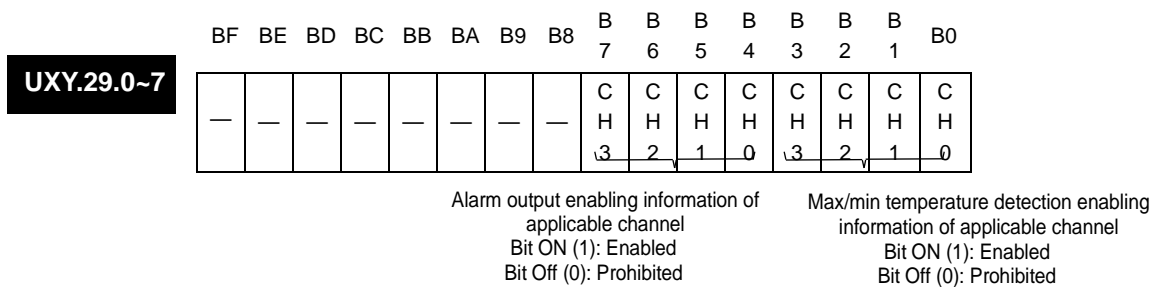

5.1.3 Operation Parameters Setting Area

- ▶ 1 word is assigned for each address in the internal memory, which can be displayed in 16 bits.
- ▶ If each bit of 16 bits configuring the address is On, let it set to “1”, and if it is Off, let it set to “0” so to realize the respective functions.

(1) Channel Enable/Disable (address No.0)

- (a) Temperature conversion can be set Enabled or Disabled for respective channels.
- (b) The conversion cycle can be reduced by setting to Disable the channel which will not be used.
- (c) If the channel to use is not specified, all the channels will be set to Disable.
- (d) Details for Enable/Disable conversion are described below.
- (e) Data of the channel unused (data read from PLC) will be all cleared to “0”.

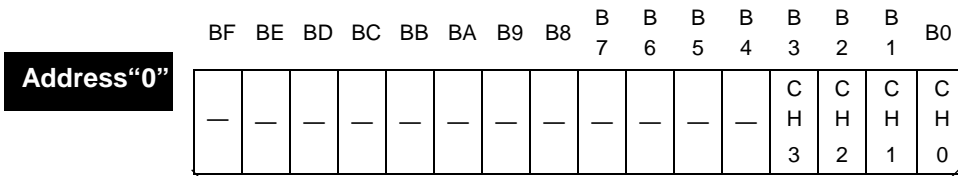

BIT	Description
0	Disable
1	Enable

- (f) The value specified in B4 ~ BF will be disregarded.
- (g) Use I/O parameter window for more convenient setting.

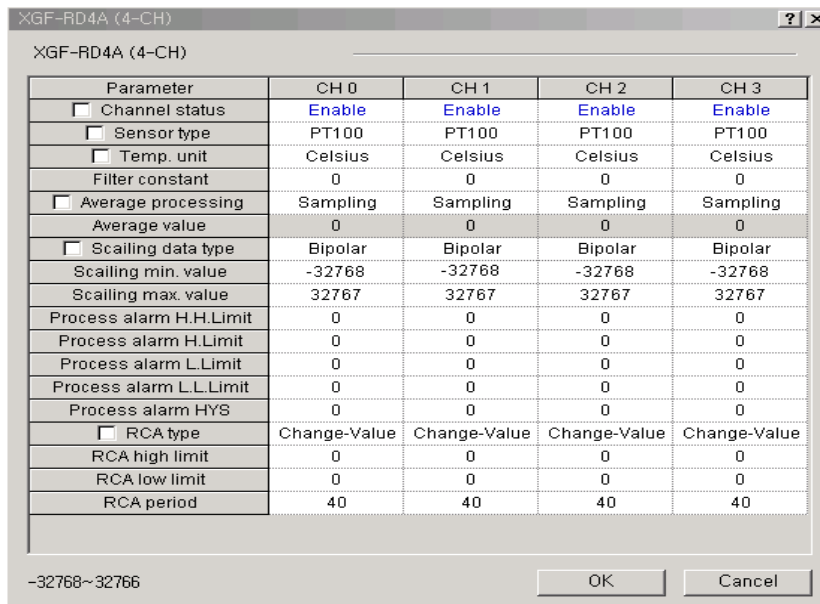

(2) Sensor type setting (addresses 1~4)

- XGF-RD4A-

- (a) 2 types of RTD sensors are available for XGF-RD4A module.
- (b) If 2 or more is input, setting error will occur (Uxy.01.8~Uxy.01.B) and the setting value will be "0"

Addresses "1~4"

BF BE BD BC BB BA B9 B8 B 7 B 6 B 5 B 4 B 3 B 2 B 1 B0

CH# sensor type setting

Word value	Description
0	PT100
1	JPT100

- XGF-RD4S-

- (a) 8 types of RTD sensors are available for XGF-RD4S module.
- (b) If 8 or more is input, setting error will occur (Uxy.01.8~ Uxy.01.B) and the setting value will be "0".

Addresses "1~4"

BF BE BD BC BB BA B9 B8 B 7 B 6 B 5 B 4 B 3 B 2 B 1 B0

CH# sensor type setting

Word value	Description
0	3-wired PT100
1	3-wired JPT100
2	3-wired PT1000
3	3-wired NI100
4	4-wired PT100
5	4-wired JPT100
6	4-wired PT1000
7	4-wired NI100

- (c) Use I/O parameter window for more convenient setting.

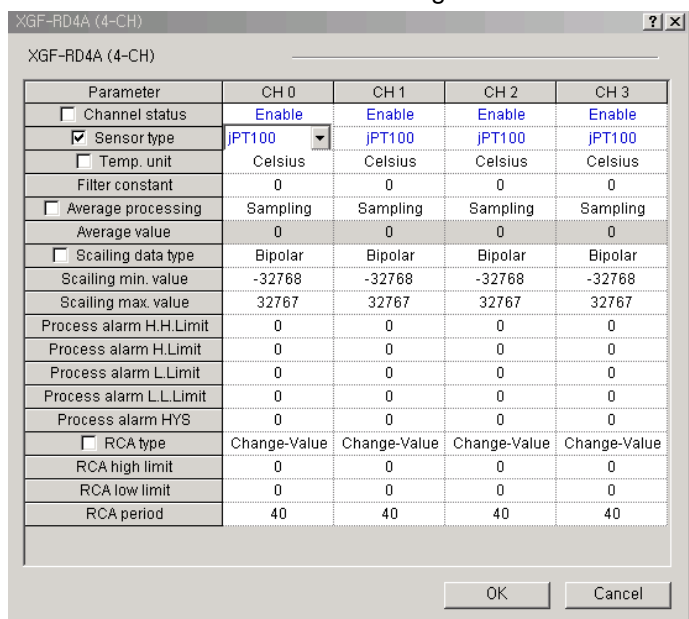

(3) Temperature conversion unit (address 5)

(a) Temperature-converted value can be output in °C or °F as specified.

Address "5"

BF	BE	BD	BC	BB	BA	B9	B8	B7	B6	B5	B4	B3	B2	B1	B0
—	—	—	—	—	—	—	—	—	—	—	—	C	C	C	C
												H	H	H	H
												3	2	1	0

BIT	Description
0	Celsius
1	Fahrenheit

(b) Use I/O parameter window for more convenient setting.

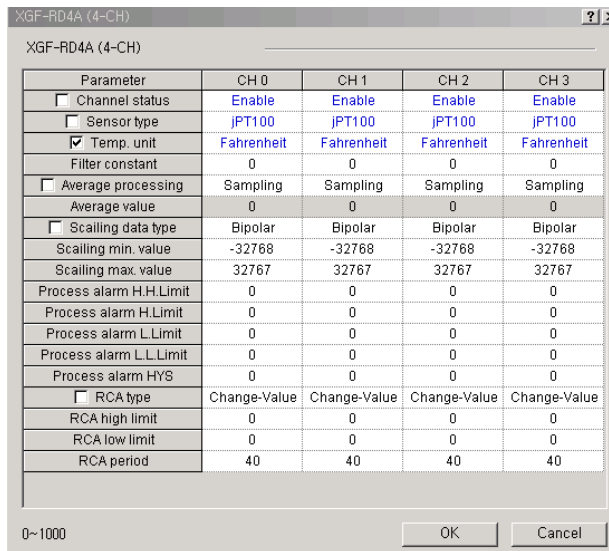

(4) Filter value (addresses 6 ~ 9)

- (a) If the filter value is set to “0”, the applicable channel will not be filtered but the sampled temperature-converted value will be output.
- (b) If set to “1 ~ 159” or “64001” or more, setting error will occur with the setting value of “0” internally produced.

Addresses “6 ~ 9”

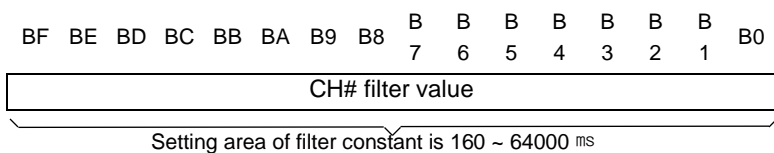

Address	Description
6	Channel 0 Filter Value Setting
7	Channel 1 Filter Value Setting
8	Channel 2 Filter Value Setting
9	Channel 3 Filter Value Setting

(c) Use I/O parameter window for more convenient setting.

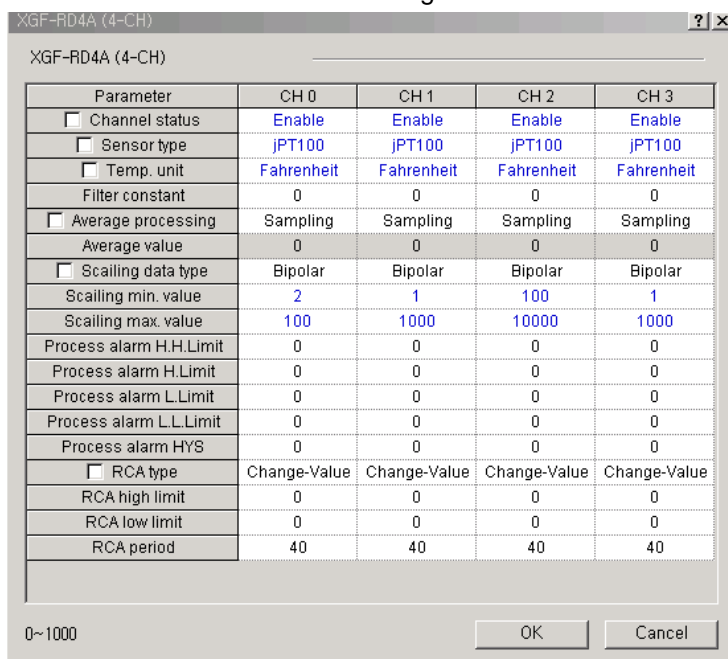

(5) Averaging process method (addresses 10~13)

(a) If set to “4” or more, setting error will occur with the setting value of “0” internally produced.

Addresses “10 ~ 13”

BF BE BD BC BB BA B9 B8 B7 B6 B5 B4 B3 B2 B1 B0

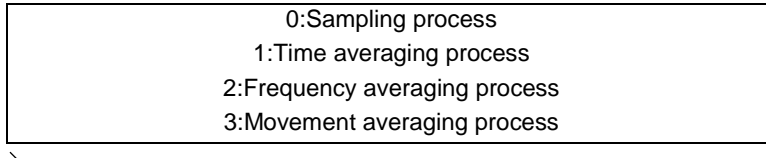

Setting area of averaging method is 0 ~ 3

Address	Description
10	Channel 0 Averaging process method setting
11	Channel 1 Averaging process method setting
12	Channel 2 Averaging process method setting
13	Channel 3 Averaging process method setting

(b) Use I/O parameter window for more convenient setting.

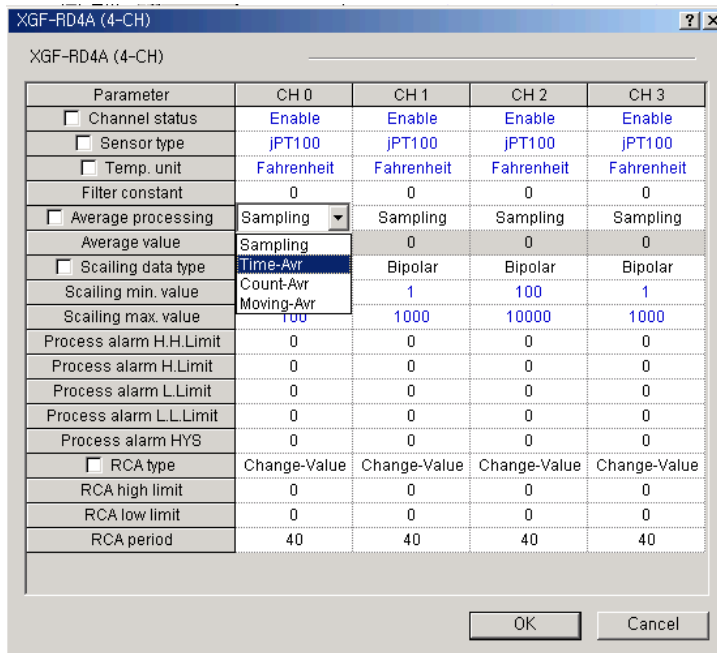

(6) Averaging value (addresses 14~17)

- (a) If the averaging method is sampling, the setting value will be disregarded.
- (b) If the averaging value is set exceeding the setting range, setting error will occur and the max/min averaging value will be specified.

Ex.) If Time average is selected with the average value of 200, setting error will occur with the setting value of "320" internally produced.

- (c) However, if [I.O Parameter] is used, other value than the range can not be specified since inputting incorrect value is prohibited by package option. (If set incorrectly, it will be displayed in red with a resetting message)

Addresses "14 ~ 17"

BF BE BD BC BB BA B9 B8 B 7 B 6 B 5 B 4 B 3 B 2 B 1 B0

Time average: 320~64000[ms]
 Frequency average: 2~64000[times]
 Movement average: 2~100[counts]

Address	Description
14	Channel 0 Average Value Setting
15	Channel 1 Average Value Setting
16	Channel 2 Average Value Setting
17	Channel 3 Average Value Setting

- (d) Use I/O parameter window for more convenient setting.

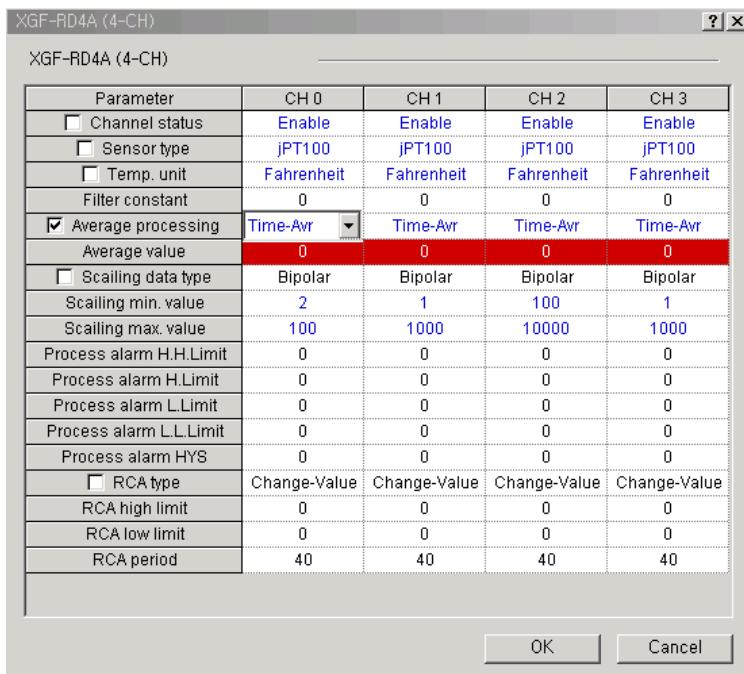

(7) Scaling data type (address 18)

- (a) If "1" is selected for the applicable bit, setting type of max/min scale range will be unsigned integer with the max. output data range of "0 ~ 65535" by scaled calculation.
- (b) If "0" is selected for the applicable bit, setting type of max/min scale range will be signed integer with the max. output data range of "-32768 ~ 32767" by scaled calculation (default).
- (c) Information specified in Bits "4~F" will be disregarded.

Address "18"

BF	BE	BD	BC	BB	BA	B9	B8	B7	B6	B5	B4	B3	B2	B1	B0
—	—	—	—	—	—	—	—	—	—	—	—	C	C	C	C
												H	H	H	H
												3	2	1	0

BIT	Description
0	Set to signed integer scale range
1	Set to unsigned integer scale range

(d) Use I/O parameter window for more convenient setting.

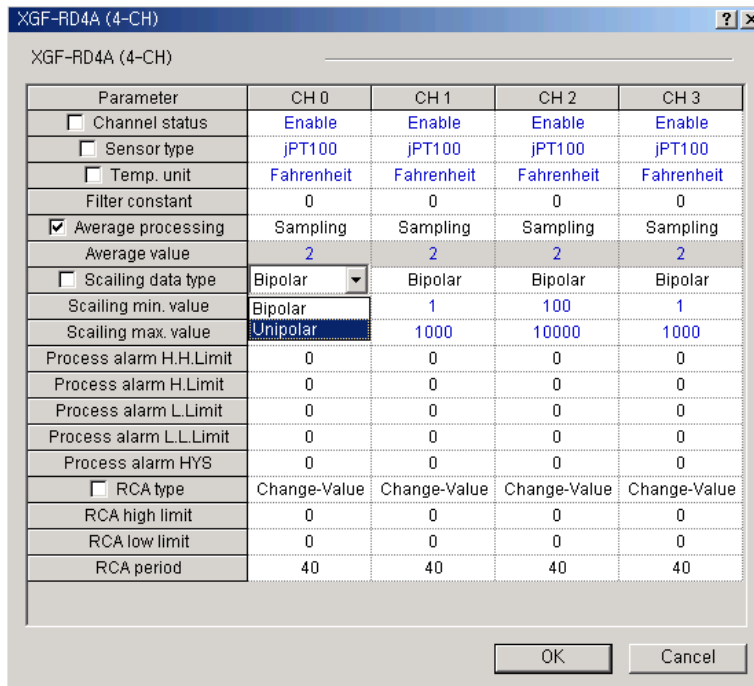

- * Bipolar: output data in the positive/negative poles (+/-) of value (Signed Integer).
- Unipolar: output data in the positive pole (+) of value (Unsigned Integer).

(8) Scaling range (address 19~26)

(a) If scale value is setting out of scaling range, setting error will occur and the setting value saved internal memory is kept.

Address“19 ~ 26”

BF BE BD BC BB BA B9 B8 B 7 B 6 B 5 B 4 B 3 B 2 B 1 B0

Signed type: -32768 ~ 32767
 Unsigned type: 0 ~ 65535

Address	Description
19	Channel 0 Scaling Range Minimum Value Setting
20	Channel 0 Scaling Range Maximum Value Setting
21	Channel 1 Scaling Range Minimum Value Setting
22	Channel 1 Scaling Range Maximum Value Setting
23	Channel 2 Scaling Range Minimum Value Setting
23	Channel 2 Scaling Range Maximum Value Setting
25	Channel 3 Scaling Range Minimum Value Setting
26	Channel 3 Scaling Range Maximum Value Setting

(b) Use I/O parameter window for more convenient setting.

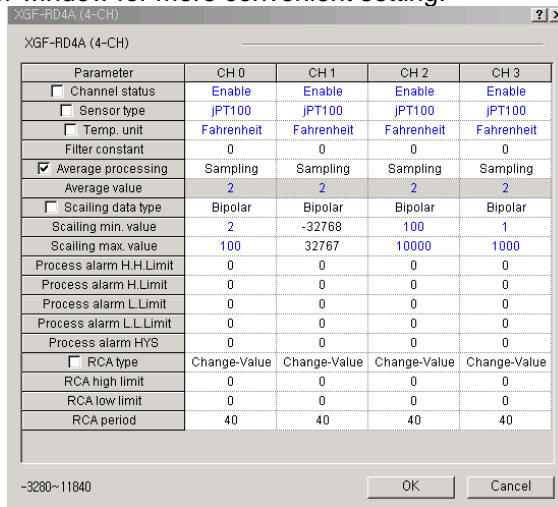

(9) Process alarm limit value (address 27~42)

- (a) Setting range can be specified individually based on the type of output temperature (°C /°F) and the type of sensor (Pt100/JPt100).
- (b) If a value other than range is set, setting error will occur with the setting value saved inside the module as kept.

Address "27 ~ 42"

B15 B14 B13 B12 B11 B10 B9 B8 B7 B6 B5 B4 B3 B2 B1 B0

Pt100 °C: -2000 ~ 8500
°F: -3280 ~ 15620
JPt100 °C: -2000 ~ 6400
°F: -3280 ~ 11840

Address	Description
27	Channel 0 Process Alarm High-High value Setting
28	Channel 0 Process Alarm High value Setting
29	Channel 0 Process Alarm Low value Setting
30	Channel 0 Process Alarm Low Low value Setting
31	Channel 1 Process Alarm High-High value Setting
32	Channel 1 Process Alarm High value Setting
33	Channel 1 Process Alarm Low value Setting
34	Channel 1 Process Alarm Low Low value Setting
35	Channel 2 Process Alarm High-High value Setting
36	Channel 2 Process Alarm High value Setting
37	Channel 2 Process Alarm Low value Setting
38	Channel 2 Process Alarm Low Low value Setting
39	Channel 3 Process Alarm High-High value Setting
40	Channel 3 Process Alarm High value Setting
41	Channel 3 Process Alarm Low value Setting
42	Channel 3 Process Alarm Low Low value Setting

- (c) Use I/O parameter window for more convenient setting.

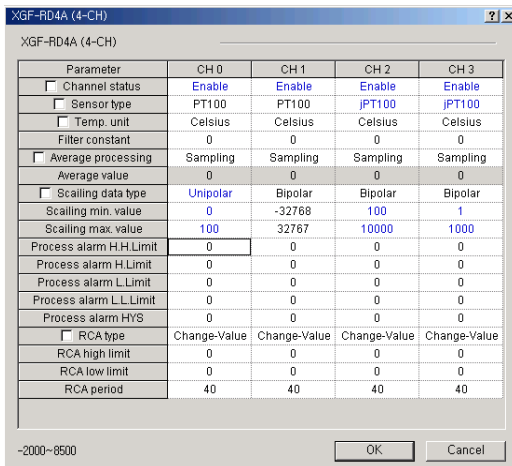

(10) Process alarm hysteresis (address 43~46)

- (a) If a value other than range is set, setting error will occur with the setting value of “0” saved inside the module as kept.
- (b) If process alarm function is used, the alarm output will be kept if set within the hysteresis value although the alarming condition is cancelled.

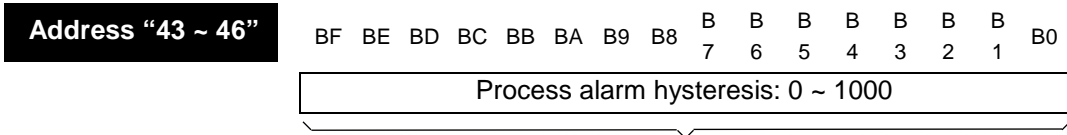

Address	Description
43	Channel 0 Process Alarm Hysteresis Setting
44	Channel 1 Process Alarm Hysteresis Setting
45	Channel 2 Process Alarm Hysteresis Setting
46	Channel 3 Process Alarm Hysteresis Setting

(c) Use I/O parameter window for more convenient setting.

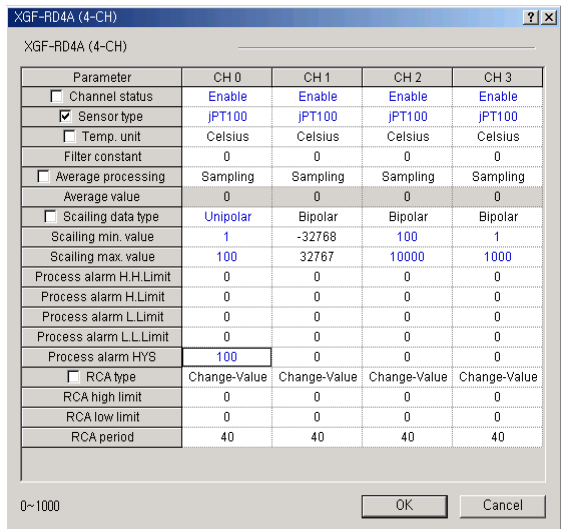

(11) Input variation alarm type (address 47)

(a) If the applicable bit is set to "1", variation rate is the criterion of alarm for applicable channel (rate for input range based on the sensor type).

Ex.) As for Pt100,

$$\text{Variation rate} = \frac{(\text{Present temperature value} - \text{Temperature value prior to alarm}) \times 100}{(8500 - (-2000))}$$

(b) If set to "0", the Temperature-converted value itself is criterion of alarm.

(c) The information specified in Bits 4 ~ F will be disregarded.

Address "47"

BF	BE	BD	BC	BB	BA	B9	B8	B7	B6	B5	B4	B3	B2	B1	B0
—	—	—	—	—	—	—	—	—	—	—	—	C	C	C	C
												H	H	H	H
												3	2	1	0

BIT	Description
0	Temperature-converted value
1	Temperature-converted rate

(d) Use I/O parameter window for more convenient setting.

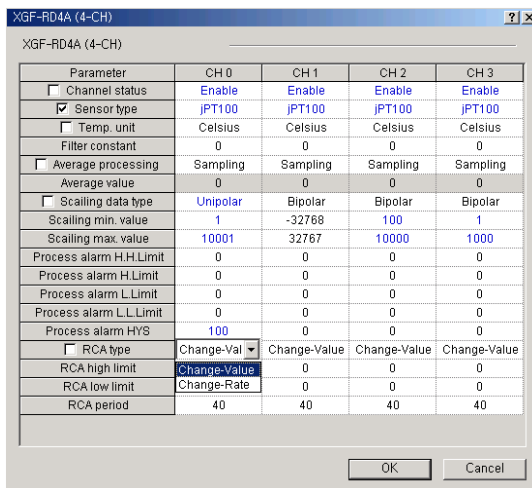

(12) Input variation alarm Max./Min. value (address 48~55)

- (a) If a value other than range is set, setting error will occur with the setting value of “0” saved inside the module.
- (b) If input variation range is set in the input variation alarm type, it will be a percentage value of input variation rate specifying to the first decimal point.
- (c) If input variation value is set in the input variation alarm type, the unit of the value to be set in this area represents temperature variation.

Address “48 ~ 55”

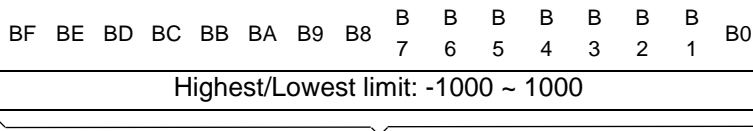

Address	Description
48	Channel 0 Input Variation Alarm Upper Limit Value Setting
49	Channel 0 Input Variation Alarm Lower Limit Value Setting
50	Channel 1 Input Variation Alarm Upper Limit Value Setting
51	Channel 1 Input Variation Alarm Lower Limit Value Setting
52	Channel 2 Input Variation Alarm Upper Limit Value Setting
53	Channel 2 Input Variation Alarm Lower Limit Value Setting
54	Channel 3 Input Variation Alarm Upper Limit Value Setting
55	Channel 3 Input Variation Alarm Lower Limit Value Setting

(d) Use I/O parameter window for more convenient setting.

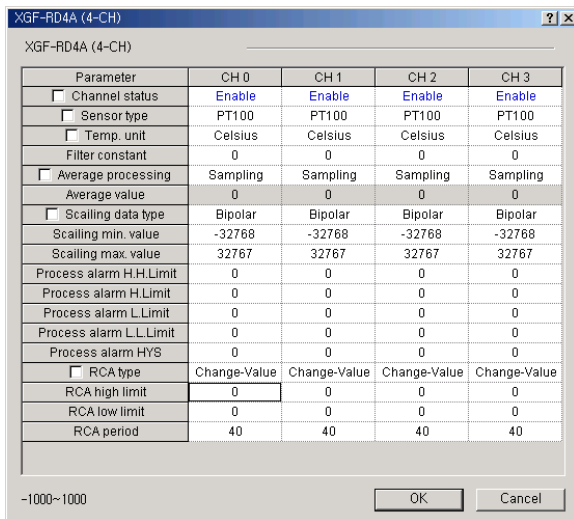

(13) Detection cycle of input variation alarm (address 56~59)

- (a) It is used to specify the detection cycle of input variation, if input variation alarming function is used.
- (b) If a value other than range is set, setting error will occur with the setting value of “40” saved inside the module as kept.

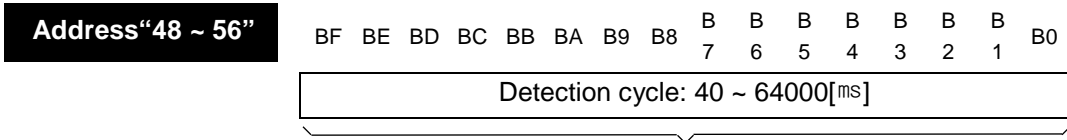

Address	Description
56	Channel 0 Input Variation Alarm Detection Cycle Setting
57	Channel 1 Input Variation Alarm Detection Cycle Setting
58	Channel 2 Input Variation Alarm Detection Cycle Setting
59	Channel 3 Input Variation Alarm Detection Cycle Setting

- (c) Use I/O parameter window for more convenient setting.

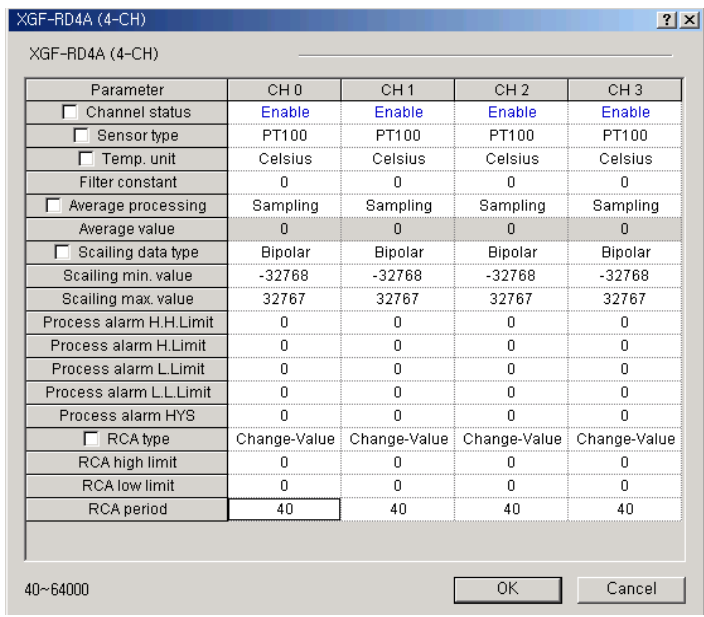

(14) Setting error information (address 60~63)

- (a) If a value other than range is set (in the PLC program), “1” will be output to the applicable bit.
- (b) Setting error can be reset if a value in normal range is input.
- (c) There will be no change in the module LED when setting error occurs. If more than 1 bits of Uxy.01.08~Uxy.01.0D turned on, check this area and its settings.
- (d) Error details and setting address of applicable bits.

- Bit 0: Setting error of CH sensor type (address 1~4)
- Bit 1: Setting error of CH filter value (address 6~9)
- Bit 2: Setting error of CH averaging type (address 10~13)
- Bit 3: Setting error of CH averaging value (address 14~17)
- Bit 4: Setting error of CH scale min. range (address 19, 21, 23, 25)
- Bit 5: Setting error of CH scale max. range (address 20, 22, 24, 26)
- Bit 6: Setting error of CH process alarm High High value (address 27,31,35,39)
- Bit 7: Setting error of CH process alarm High value (address 28, 32, 36, 40)
- Bit 8: Setting error of CH process alarm Low value (address 29, 33, 37, 41)
- Bit 9: Setting error of CH process alarm Low Low value (address 30, 34, 38, 42)
- Bit A: Setting error of CH process alarm hysteresis (address 39~46)
- Bit B: Setting error of CH input variation alarm Max. value (address 48, 50, 52, 54)
- Bit C: Setting error of CH input variation alarm Min. value (address 49, 51, 53, 55)
- Bit D: Setting error of CH input variation alarm detection cycle (address 56~59)

Address “60~63”

BF	BE	BD	BC	BB	BA	B9	B8	B7	B6	B5	B4	B3	B2	B1	B0
—	—	C	C	C	C	C	C	C	C	C	C	C	C	C	C
		H	H	H	H	H	H	H	H	H	H	H	H	H	H
		0	0	0	0	0	0	0	0	0	0	0	0	0	0

Address	Description
60	Channel 0 Setting Error Information Output
61	Channel 1 Setting Error Information Output
62	Channel 2 Setting Error Information Output
63	Channel 3 Setting Error Information Output

Chapter 5 Internal Memory Configuration and Function (For XGK)

(15) Input variation value/rate output (address 64~67)

- (a) The amount of changes in input temperature or variation rate (rate % based on the sensor range) is saved every detection cycle of input variation alarm specified.
- (b) Monitoring with [Special module monitoring] is also available.

Address "64 ~ 67"

BF BE BD BC BB BA B9 B8 B 7 B 6 B 5 B 4 B 3 B 2 B 1 B0

Variation rate: -1023 ~ 1023
Variation value: Pt100: -10700 ~ 10700
JPt100: -8600 ~ 8600

Address	Description
64	Channel 0 Variation Value (Variation Rate) Output of Input Variation Alarm
65	Channel 1 Variation Value (Variation Rate) Output of Input Variation Alarm
66	Channel 2 Variation Value (Variation Rate) Output of Input Variation Alarm
67	Channel 3 Variation Value (Variation Rate) Output of Input Variation Alarm

- (c) In order to monitor the variation value (variation rate) of input variation alarm, open FLAG monitoring window and set the alarm operation Enabled also on the [Special module monitoring] window.

Item	CH 0	CH 1
Temperature value	1349	0
Scalling value	-11865	0
Min. temp value	1349	0
Max. temp value	1351	0
Input change(value/rate)	-1	0
Item	CH 2	CH 3
Temperature value	0	0
Scalling value	0	0
Min. temp value	0	0
Max. temp value	0	0
Input change(value/rate)	0	0
FLAG Monitor		

Item	Setting value	Current value
CH 0		
Channel status	Disable	Enable
Sensor type	PT100	PT100
Temp. unit	Celsius	Celsius
Filter constant	0	0
Average processing	Sampling	Sampling
Average value	0	0
Scalling data type	Bipolar	Bipolar
Scalling min. value	-32768	-32768
Scalling max. value	32767	32767
Process alarm H.H.Limit	0	0
Process alarm H.Limit	0	0
Process alarm L.Limit	0	0
Process alarm L.Limit	0	0
Process alarm HYS	0	0
RCA type	Change-Value	Change-Value
RCA high limit	Change-Value	0
RCA low limit	Change-Rate	0
RCA period	40	40

Item	CH 0	CH 1
Channel status	Run	Stop
Sensor status	Normal	Normal
Process alarm(H.H.Limit)	ON	OFF
Process alarm(H.Limit)	ON	OFF
Process alarm(L.Limit)	OFF	OFF
Process alarm(LL.Limit)	OFF	OFF
RCA high limit	ON	OFF
RCA low limit	ON	OFF
Item	CH 2	CH 3
Channel status	Stop	Stop
Sensor status	Normal	Normal
Process alarm(H.H.Limit)	OFF	OFF
Process alarm(H.Limit)	OFF	OFF
Process alarm(L.Limit)	OFF	OFF
Process alarm(LL.Limit)	OFF	OFF
RCA high limit	OFF	OFF
RCA low limit	OFF	OFF

Command	CH 0	CH 1
Max/Min active	ENABLE	DISABLE
Alarm active	ENABLE	DISABLE
Command	CH 2	CH 3
Max/Min active	DISABLE	DISABLE
Alarm active	DISABLE	DISABLE

- (16) Sensor disconnection information (address 68~71)
 (a) It is used to output the disconnection information.

- XGF-RD4A-

Address“64 ~ 67”

BF BE BD BC BB BA B9 B8 B 7 B 6 B 5 B 4 B 3 B 2 B 1 B0

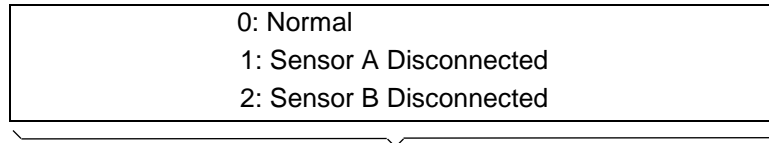

Address	Description
68	Channel 0 Sensor Disconnection Information Output
69	Channel 1 Sensor Disconnection Information Output
70	Channel 2 Sensor Disconnection Information Output
71	Channel 3 Sensor Disconnection Information Output

- XGF-RD4S-

Address“64 ~ 67”

BF BE BD BC BB BA B9 B8 B 7 B 6 B 5 B 4 B 3 B 2 B 1 B0

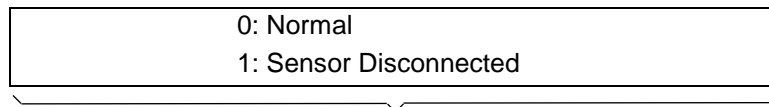

Address	Description
68	Channel 0 Sensor Disconnection Information Output
69	Channel 1 Sensor Disconnection Information Output
70	Channel 2 Sensor Disconnection Information Output
71	Channel 3 Sensor Disconnection Information Output

5.2 XGF-RD8A Module

Explain configuration of internal memories.

5.2.1 Internal Memory Configuration

(1) Input/Output area of conversion data (U Device)

Table 5.1 shows the conversion data input/output area of the RTD module.

[Table 5. 4] Conversion data input/output area

Device Assignment	Description	R/W	Signal Direction
UXY.00.0 UXY.00.1 UXY.00.2 UXY.00.3 UXY.00.4 UXY.00.5 UXY.00.6 UXY.00.7 UXY.00.D Uxy.00.E Uxy.00.F	Channel 0 Off/Gain Adjust Error Channel 1 Off/Gain Adjust Error Channel 2 Off/Gain Adjust Error Channel 3 Off/Gain Adjust Error Channel 4 Off/Gain Adjust Error Channel 5 Off/Gain Adjust Error Channel 6 Off/Gain Adjust Error Channel 7 Off/Gain Adjust Error Module Off/Gain Backup Error Module Hardware Error Ready	R	RTD input → CPU
UXY.01.0 UXY.01.1 UXY.01.2 UXY.01.3 UXY.01.4 UXY.01.5 UXY.01.6 UXY.01.7 UXY.01.8 UXY.01.9 UXY.01.A UXY.01.B UXY.01.C UXY.01.D UXY.01.E UXY.01.F	Channel 0 Operation Flag Channel 1 Operation Flag Channel 2 Operation Flag Channel 3 Operation Flag Channel 4 Operation Flag Channel 5 Operation Flag Channel 6 Operation Flag Channel 7 Operation Flag Channel 0 Disconnection Flag Channel 1 Disconnection Flag Channel 2 Disconnection Flag Channel 3 Disconnection Flag Channel 4 Disconnection Flag Channel 5 Disconnection Flag Channel 6 Disconnection Flag Channel 7 Disconnection Flag	R	RTD input → CPU
UXY.02.0 UXY.02.1 UXY.02.2 UXY.02.3 UXY.02.4 UXY.02.5 UXY.02.6 UXY.02.7	Channel 0 Setting Error Channel 1 Setting Error Channel 2 Setting Error Channel 3 Setting Error Channel 4 Setting Error Channel 5 Setting Error Channel 6 Setting Error Channel 7 Setting Error	R	RTD input → CPU

Chapter5 Internal Memory Configuration and Function (For XGK)

Device Assignment	Description	R/W	Signal Direction
UXY.03.0	Channel 0 Process Alarm Low-Low Limit Flag	R	RTD input → CPU
UXY.03.1	Channel 0 Process Alarm Low Limit Flag		
UXY.03.2	Channel 0 Process Alarm High Limit Flag		
UXY.03.3	Channel 0 Process Alarm High-High Limit Flag		
UXY.03.4	Channel 1 Process Alarm Low-Low Limit Flag		
UXY.03.5	Channel 1 Process Alarm Low Limit Flag		
UXY.03.6	Channel 1 Process Alarm High Limit Flag		
UXY.03.7	Channel 1 Process Alarm High-High Limit Flag		
UXY.03.8	Channel 2 Process Alarm Low-Low Limit Flag		
UXY.03.9	Channel 2 Process Alarm Low Limit Flag		
UXY.03.A	Channel 2 Process Alarm High Limit Flag		
UXY.03.B	Channel 2 Process Alarm High-High Limit Flag		
UXY.03.C	Channel 3 Process Alarm Low-Low Limit Flag		
UXY.03.D	Channel 3 Process Alarm Low Limit Flag		
UXY.03.E	Channel 3 Process Alarm High Limit Flag		
UXY.03.F	Channel 3 Process Alarm High-High Limit Flag		
UXY.04.0	Channel 4 Process Alarm Low-Low Limit Flag		
UXY.04.1	Channel 4 Process Alarm Low Limit Flag		
UXY.04.2	Channel 4 Process Alarm High Limit Flag		
UXY.04.3	Channel 4 Process Alarm High-High Limit Flag		
UXY.04.4	Channel 5 Process Alarm Low-Low Limit Flag		
UXY.04.5	Channel 5 Process Alarm Low Limit Flag		
UXY.04.6	Channel 5 Process Alarm High Limit Flag		
UXY.04.7	Channel 5 Process Alarm High-High Limit Flag		
UXY.04.8	Channel 6 Process Alarm Low-Low Limit Flag		
UXY.04.9	Channel 6 Process Alarm Low Limit Flag		
UXY.04.A	Channel 6 Process Alarm High Limit Flag		
UXY.04.B	Channel 6 Process Alarm High-High Limit Flag		
UXY.04.C	Channel 7 Process Alarm Low-Low Limit Flag		
UXY.04.D	Channel 7 Process Alarm Low Limit Flag		
UXY.04.E	Channel 7 Process Alarm High Limit Flag		
UXY.04.F	Channel 7 Process Alarm High-High Limit Flag		
UXY.05.0	Channel 0 Input Variation Alarm Lower Limit Flag	R	RTD input → CPU
UXY.05.1	Channel 0 Input Variation Alarm Upper Limit Flag		
UXY.05.2	Channel 1 Input Variation Alarm Lower Limit Flag		
UXY.05.3	Channel 1 Input Variation Alarm Upper Limit Flag		
UXY.05.4	Channel 2 Input Variation Alarm Lower Limit Flag		
UXY.05.5	Channel 2 Input Variation Alarm Upper Limit Flag		
UXY.05.6	Channel 3 Input Variation Alarm Lower Limit Flag		
UXY.05.7	Channel 3 Input Variation Alarm Upper Limit Flag		
UXY.05.8	Channel 4 Input Variation Alarm Lower Limit Flag		
UXY.05.9	Channel 4 Input Variation Alarm Upper Limit Flag		
UXY.05.A	Channel 5 Input Variation Alarm Lower Limit Flag		
UXY.05.B	Channel 5 Input Variation Alarm Upper Limit Flag		
UXY.05.C	Channel 6 Input Variation Alarm Lower Limit Flag		
UXY.05.D	Channel 6 Input Variation Alarm Upper Limit Flag		
UXY.05.E	Channel 7 Input Variation Alarm Lower Limit Flag		
UXY.05.F	Channel 7 Input Variation Alarm Upper Limit Flag		
UXY.06	Channel 0 Temperature-converted value	R	RTD input → CPU
UXY.07	Channel 1 Temperature-converted value	R	
UXY.08	Channel 2 Temperature-converted value	R	
UXY.09	Channel 3 Temperature-converted value	R	
UXY.10	Channel 4 Temperature-converted value	R	
UXY.11	Channel 5 Temperature-converted value	R	
UXY.12	Channel 6 Temperature-converted value	R	
UXY.13	Channel 7 Temperature-converted value	R	
UXY.14	Channel 0 Scaled value	R	

Chapter 5 Internal Memory Configuration and Function (For XGK)

Device Assignment	Description	R/W	Signal Direction
UXY.14	Channel 1 Scaled value	R	
UXY.16	Channel 2 Scaled value	R	
UXY.17	Channel 3 Scaled value	R	
UXY.18	Channel 0 Scaled value	R	
UXY.19	Channel 1 Scaled value	R	
UXY.20	Channel 2 Scaled value	R	
UXY.21	Channel 3 Scaled value	R	
UXY.22.0 UXY.22.1 UXY.22.2 UXY.22.3 UXY.22.4 UXY.22.5 UXY.22.6 UXY.22.7 UXY.22.8 UXY.22.9 UXY.22.A UXY.22.B UXY.22.C UXY.22.D UXY.22.E UXY.22.F	Channel 0 Min/Min. Value Detection Channel 1 Min/Min. Value Detection Channel 2 Min/Min. Value Detection Channel 3 Min/Min. Value Detection Channel 4 Min/Min. Value Detection Channel 5 Min/Min. Value Detection Channel 6 Min/Min. Value Detection Channel 7 Min/Min. Value Detection Channel 0 Alarm (Process alarm/Change rate alarm) Channel 1 Alarm (Process alarm/Change rate alarm) Channel 2 Alarm (Process alarm/Change rate alarm) Channel 3 Alarm (Process alarm/Change rate alarm) Channel 4 Alarm (Process alarm/Change rate alarm) Channel 5 Alarm (Process alarm/Change rate alarm) Channel 6 Alarm (Process alarm/Change rate alarm) Channel 7 Alarm (Process alarm/Change rate alarm)	R	CPU → RTD input

- (a) In the device assigned, X stands for the Base No. and Y for the Slot No. on which module is installed.
- (b) In order to read 'CH0 temperature-converted value' of RTD input installed on Base No.0, Slot No.4, its address be U04.06.

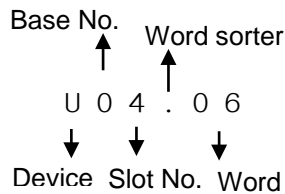

- (c) In order to read 'Flag to detect CH3 disconnection' of RTD module installed on Base No.0, Slot No.5, its address shall be U05.1.B.
- (In case that RTD module installed on Slot No.10, its address shall be U0A.1.B)

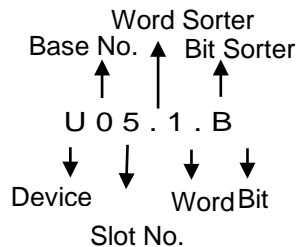

(2) Operation parameter setting area (PUT/GET)

Table 5.6 shows the operation parameter setting area of the XGF-RD8A module and each address has double word size

[Table 5.6] Operation parameter setting area

Address			Description		R/W	Remark
Hex.	Dec	Upper(Word)	Lower(Word)			
0H _H	0L _H	0	Unused	Operation enable/disable Setting	Read/ Write	GETE/ PUTE
1H _H	1L _H	1	Channel 4 Sensor Type Setting	Channel 0 sensor type setting		
2H _H	2L _H	2	Channel 5 Sensor Type Setting	Channel 1 sensor type setting		
3H _H	3L _H	3	Channel 6 Sensor Type Setting	Channel 2 sensor type setting		
4H _H	4L _H	4	Channel 7 Sensor Type Setting	Channel 3 sensor type setting		
5L _H	5L _H	5	Unused	Temperature type Setting		
6H _H	6L _H	6	Channel 4 filter value setting	Channel 0 filter value setting		
7H _H	7L _H	7	Channel 5 filter value setting	Channel 1 filter value setting		
8H _H	8L _H	8	Channel 6 filter value setting	Channel 2 filter value setting		
9H _H	9L _H	9	Channel 7 filter value setting	Channel 3 filter value setting		
AH _H	AL _H	10	Channel 4~7 average processing method setting	Channel 0~3 average processing method setting		
BH _H	BL _H	11				
CH _H	CL _H	12				
DH _H	DL _H	13				
EH _H	EL _H	14	Channel 4~7 average value setting	Channel 0~3 average value setting		
FH _H	FL _H	15				
10H _H	10L _H	16				
11H _H	11L _H	17				
12H _H	12L _H	18	Unused	Scaling data type setting		
13H _H	13L _H	19	Channel 4 scaled range min. value setting	Channel 0 scaled range min. value setting		
14H _H	14L _H	20	Channel 4 scaled range max. value setting	Channel 0 scaled range max. value setting		
15H _H	15L _H	21	Channel 5 scaled range min. value setting	Channel 1 scaled range min. value setting		
16H _H	16L _H	22	Channel 5 scaled range max. value setting	Channel 1 scaled range max. value setting		
17H _H	17L _H	23	Channel 6 scaled range min. value setting	Channel 2 scaled range min. value setting		
18H _H	18L _H	24	Channel 6 scaled range max. value setting	Channel 2 scaled range max. value setting		
19H _H	19L _H	25	Channel 7 scaled range min. value setting	Channel 3 scaled range min. value setting		
1AH _H	1AL _H	26	Channel 7 scaled range max. value setting	Channel 3 scaled range max. value setting		
1BH _H	1BL _H	27	Channel 4 process alarm low limit setting	Channel 0 process alarm high-high limit setting		
1CH _H	1CL _H	28	Channel 4 process alarm low limit setting	Channel 0 process alarm high limit setting		
1DH _H	1DL _H	29	Channel 4 process alarm low limit setting	Channel 0 process alarm low limit setting		
1EH _H	1EL _H	30	Channel 4 process alarm low limit setting	Channel 0 process alarm low-low limit setting		
1FH _H	1FL _H	31	Channel 5 process alarm low limit setting	Channel 1 process alarm high-high limit setting		
20H _H	20L _H	32	Channel 5 process alarm low limit setting	Channel 1 process alarm high limit setting		
21H _H	21L _H	33	Channel 5 process alarm low limit setting	Channel 1 process alarm high limit setting		

[Table 5.6] Operation parameter setting area

Address			Description		R/W	Remark
Hex.	Dec	Upper(Word)	Lower(Word)			
22H _H	22L _H	34	Channel 5 process alarm low limit setting	Channel 1 process alarm low-low limit setting	Read/ Write	GETE/ PUTE
23H _H	23L _H	35	Channel 6 process alarm low limit setting	Channel 2 process alarm low limit setting		
24H _H	24L _H	36	Channel 6 process alarm low limit setting	Channel 2 process alarm low limit setting		
25L _H	25L _H	37	Channel 6 process alarm low limit setting	Channel 2 process alarm low limit setting		
26H _H	26L _H	38	Channel 6 process alarm low limit setting	Channel 2 process alarm low limit setting		
27H _H	27L _H	39	Channel 7 process alarm low limit setting	Channel 3 process alarm low limit setting		
28H _H	28L _H	40	Channel 7 process alarm low limit setting	Channel 3 process alarm low limit setting		
29H _H	29L _H	41	Channel 7 process alarm low limit setting	Channel 3 process alarm low limit setting		
2AH _H	2AL _H	42	Channel 7 process alarm low limit setting	Channel 3 process alarm low limit setting		
2BH _H	2BL _H	43	Channel 4~7 average processing method setting	Channel 0~3 process alarm hysteresis setting		
2CH _H	2CL _H	44				
2DH _H	2DL _H	45				
2EH _H	2EL _H	46	Unused	Change rate alarm type setting		
2FH _H	2FL _H	47				
30H _H	30L _H	48	Channel 4 change rate alarm upper limit setting	Channel 0 change rate alarm upper limit setting		
31H _H	31L _H	49	Channel 4 change rate alarm lower limit setting	Channel 0 change rate alarm lower limit setting		
32H _H	32L _H	50	Channel 5 change rate alarm upper limit setting	Channel 1 change rate alarm upper limit setting		
33H _H	33L _H	51	Channel 5 change rate alarm lower limit setting	Channel 1 change rate alarm lower limit setting		
34H _H	34L _H	52	Channel 6 change rate alarm upper limit setting	Channel 2 change rate alarm upper limit setting		
35H _H	35L _H	53	Channel 6 change rate alarm lower limit setting	Channel 2 change rate alarm lower limit setting		
36H _H	36L _H	54	Channel 7 change rate alarm upper limit setting	Channel 3 change rate alarm upper limit setting		
37H _H	37L _H	55	Channel 7 change rate alarm lower limit setting	Channel 3 change rate alarm lower limit setting		
38H _H	38L _H	56	Channel 4~7 change rate alarm detection cycle setting	Channel 0~3 change rate alarm detection cycle setting		
39H _H	39L _H	57				
3AH _H	3AL _H	58				
3BH _H	3BL _H	59	Channel 4~7 setting error information (flag)	Channel 0~3 setting error information (flag)		
3CH _H	3CL _H	60				
3DH _H	3DL _H	61				
3EH _H	3EL _H	62				
3FH _H	3FL _H	63	Channel 4~7 input change value(input change rate alarm function value)	Channel 0~3 input change value(input change rate alarm function value)		
40H _H	40L _H	64				
41H _H	41L _H	65				
42H _H	42L _H	66				
43H _H	43L _H	67				

[Table 5.6] Operation parameter setting area

Address			Description		R/W	Remark
Hex.	Dec	Upper(Word)	Lower(Word)			
44H _H	44L _H	68	Channel 4~7 Disconnection Information (code)	Channel 0~3 Disconnection Information (code)	Read	GETE
45H _H	45L _H	69				
46H _H	46L _H	70				
47H _H	47L _H	71				
48H _H	48L _H	72	Channel 4 temperature-converted min. value	Channel 0 temperature-converted min. value		
49H _H	49L _H	73	Channel 4 temperature-converted max. value	Channel 0 temperature-converted max. value		
4AH _H	4AL _H	74	Channel 5 temperature-converted min. value	Channel 1 temperature-converted min. value		
4BH _H	4BL _H	75	Channel 5 temperature-converted max. value	Channel 1 temperature-converted max. value		
4CH _H	4CL _H	76	Channel 6 temperature-converted min. value	Channel 2 temperature-converted min. value		
4DH _H	4DL _H	77	Channel 6 temperature-converted max. value	Channel 2 temperature-converted max. value		
4EH _H	4EL _H	78	Channel 7 temperature-converted min. value	Channel 3 temperature-converted min. value		
4FH _H	4FL _H	79	Channel 7 temperature-converted max. value	Channel 3 temperature-converted max. value		
50H _H	50L _H	80	Channel 4~7 data upload time	Channel 0~3 data upload time		
52H _H	52L _H	82				
54H _H	54L _H	84				
56H _H	56L _H	86				
80H _H	80L _H	128	Unused	User offset/gain mode channel setting	Read/Write	GETE/PUTE
81H _H	81L _H	129	Unused	User offset/gain mode type setting		
82H _H	82L _H	130	Unused	User offset/gain mode request		
83H _H	83L _H	131	Unused	User offset/gain mode completed		
84H _H	84L _H	132	Channel 4~7 user offset value	Channel 0~3 user offset value		
85H _H	85L _H	133				
86H _H	86L _H	134				
87H _H	87L _H	135				
8CH _H	8CL _H	140	Channel 4~7 user gain value	Channel 0~3 user gain value		
8DH _H	8DL _H	141				
8EH _H	8EL _H	142				
8FH _H	8FL _H	143				
94H _H	94L _H	148	Channel 4~7 user offset/gain mode	Channel 0~3 user offset/gain mode write		
95H _H	95L _H	149				
96H _H	96L _H	150				
97H _H	97L _H	151	Channel 4~7 error code in user offset and gain mode	Channel 0~3 eError code in user offset and gain mode		
9CH _H	9CL _H	156				
9DH _H	9DL _H	157				
9EH _H	9EL _H	158				
9FH _H	9FL _H	159	Unused	User offset and gain data move start command for on-line module change		
C0H _H	C0L _H	192				
C4H _H	C4L _H	196	Unused	Save completion of user offset and gain value for on-line module change		

[Table 5.6] Operation parameter setting area

Address			Description		R/W	Remark
Hex.		Dec	Upper(Word)	Lower(Word)		
C8 _H	C8 _L	200	Channel 4~7 user offset value for online module change	Channel 0~3 user offset value for online module change	Read/Write	GETE/PUTE
C9 _H	C9 _L	201				
CA _H	CA _L	202				
CB _H	CB _L	203				
CCH _H	CCL _H	204	Channel 4~7 user gain value for online module change	Channel 0~3 user gain value for online module change		
CD _H	CD _L	205				
CE _H	CE _L	206				
CF _H	CF _L	207				
D0 _H	D0 _L	208	Channel 4~7 user scale offset value for online module change	Channel 0~3 user scale offset value for online module change	Read/Write	GETE/PUTE
D2 _H	D2 _L	210				
D3 _H	D4 _L	212				
D6 _H	D6 _L	214				
D8 _H	D8 _L	216	Channel 4~7 user scale gain value for online module change	Channel 0~3 user scale gain value for online module change		
DA _H	DAL _H	218				
DCH _H	DCL _H	220				
DE _H	DEL _H	222				
E6 _H	E6 _L	230	Channel 4~7 upload offset value for online module change	Channel 0~3 upload offset value for online module change		
E7 _H	E7 _L	231				
E8 _H	E8 _L	232				
E9 _H	E9 _L	233				
EA _H	EAL _H	234	Channel 4~7 upload gain value for online module change	Channel 0~3 upload gain value for online module change	Read/Write	GETE/PUTE
EB _H	EB _L	235				
ECH _H	ECL _H	236				
ED _H	ED _L	237				
EE _H	EEL _H	238	Channel 4~7 upload scale offset value for online module change	Channel 0~3 upload scale offset value for online module change		
F0 _H	F0 _L	240				
F2 _H	F2 _L	242				
F4 _H	F4 _L	244				
F6 _H	F6 _L	246	Channel 4~7 upload scale gain value for online module change	Channel 0~3 upload scale gain value for online module change		
F8 _H	F8 _L	248				
FA _H	FAL _H	250				
FCH _H	FCL _H	252				

※ R/W means Read/Write availability.

Notes

- One memory divides into upper and lower word in operation parameter area in XGF-RD8A.
- Internal memory of special module at XGF-RD8A dedicated command selects word address 0 to lower word and 1 to upper word respectively.

5.2.2 Internal Memory Functions

(1) Module READY/ERROR flag (UXY.00, X: Base No., Y: Slot No.)

- (a) UXY.00.F: It will be ON when PLC CPU is powered or reset with RTD module completely ready.
- (b) UXY.00.E: Module H/W error. If "ON", refer to Chapter 9 Troubleshooting.
- (c) UXY.00.D: Module offset/gain memory error. Refer to Chapter 9 Troubleshooting if ON.
- (d) UXY.00.7~0: Offset/gain adjustment error of the applicable channel.
If "ON", it means that Offset value, Gain value, or that there is disconnection when adjusted. Refer to Chapter 9 Troubleshooting

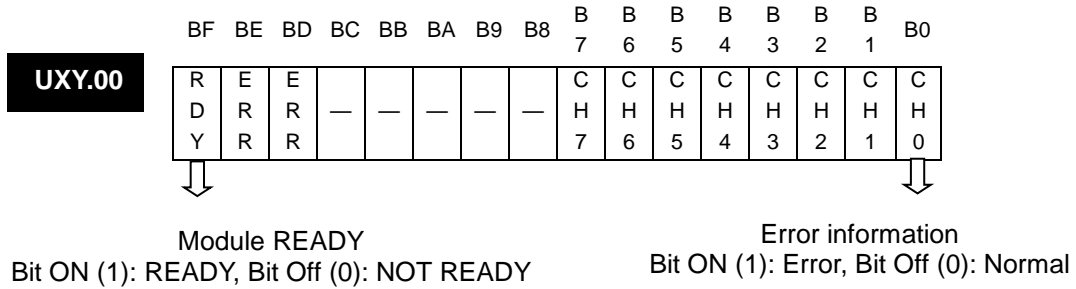

(2) Run channel flag (UXY.01, X: Base No., Y: Slot No.)

Run information of respective channels is saved.

- (a) UXY.01.F~8: It displays disconnection of the applicable channel. If it is 1", see information area of disconnection (address 68~71).
- (b) UXY.01.7~0: It displays run status of the applicable channel. If the applicable channel bit of "Used CH setting area (address 0)" is set to 1, it will be 1.

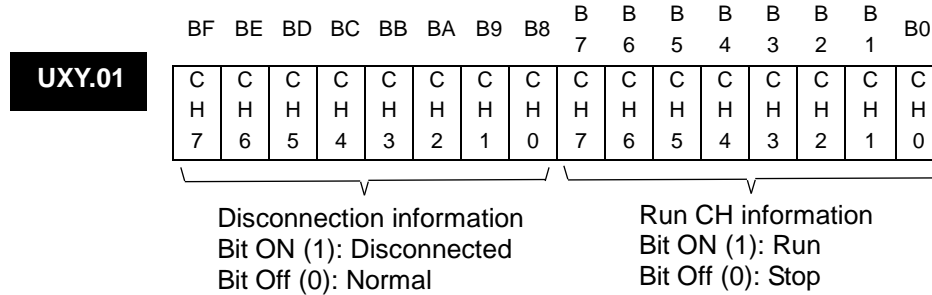

(3) Flag to output process alarm (UXY.02 , X: Base No., Y: Slot No.)

(a) UXY.01.7~0: Setting value error of the applicable channel.

								B	B	B	B	B	B	B	B0
								7	6	5	4	3	2	1	0
UXY.02								C	C	C	C	C	C	C	C
								H	H	H	H	H	H	H	H
								7	6	5	4	3	2	1	0

Set value error
Bit ON (1): Error
Bit Off (0): Normal

(4) Flag to output process alarm (UXY.03~04 , X: Base No., Y: Slot No.)

- (a) UXY.03.F~C: Flag to output process alarm of CH3 (High-High, High, Low, Low-Low)
- (b) UXY.03.B~8: Flag to output process alarm of CH2 (High-High, High, Low, Low-Low)
- (c) UXY.03.7~4: Flag to output process alarm of CH1 (High-High, High, Low, Low-Low)
- (d) UXY.03.3~0: Flag to output process alarm of CH0 (High-High, High, Low, Low-Low)
- (e) UXY.04.F~C: Flag to output process alarm of CH7 (High-High, High, Low, Low-Low)
- (f) UXY.04.B~8: Flag to output process alarm of CH6 (High-High, High, Low, Low-Low)
- (g) UXY.04.7~4: Flag to output process alarm of CH5 (High-High, High, Low, Low-Low)
- (h) UXY.04.3~0: Flag to output process alarm of CH4 (High-High, High, Low, Low-Low)

								B	B	B	B	B	B	B	B0
								7	6	5	4	3	2	1	0
UXY.03								C	C	C	C	C	C	C	C
								H	H	H	H	H	H	H	H
								3	3	3	3	2	2	2	2

CH 3 alarm information CH 2 alarm information CH 1 alarm information CH 0 alarm information
Bit ON (1): Alarm occurred Bit ON (1): Alarm occurred Bit ON (1): Alarm occurred Bit ON (1): Alarm occurred
Bit Off (0): Normal Bit Off (0): Normal Bit Off (0): Normal Bit Off (0): Normal

								B	B	B	B	B	B	B	B0
								7	6	5	4	3	2	1	0
UXY.04								C	C	C	C	C	C	C	C
								H	H	H	H	H	H	H	H
								7	7	7	7	6	6	6	6

CH 7 alarm information CH 6 alarm information CH 5 alarm information CH 4 alarm information
Bit ON (1): Alarm occurred Bit ON (1): Alarm occurred Bit ON (1): Alarm occurred Bit ON (1): Alarm occurred
Bit Off (0): Normal Bit Off (0): Normal Bit Off (0): Normal Bit Off (0): Normal

(5) Flag to output input change rate alarm (UXY.05 , X: Base No., Y: Slot No.)

- (a) UXY.05.F~E: Flag to output input change (amount/rate) alarm of CH7 (highest/lowest)
- (b) UXY.05.D~C: Flag to output input change (amount/rate) alarm of CH6 (highest/lowest)
- (c) UXY.05.B~A: Flag to output input change (amount/rate) alarm of CH5 (highest/lowest)
- (d) UXY.05.9~8: Flag to output input change (amount/rate) alarm of CH4 (highest/lowest)
- (e) UXY.05.7~6: Flag to output input change (amount/rate) alarm of CH3 (highest/lowest)
- (f) UXY.05.5~4: Flag to output input change (amount/rate) alarm of CH2 (highest/lowest)
- (g) UXY.05.3~2: Flag to output input change (amount/rate) alarm of CH1 (highest/lowest)
- (h) UXY.05.1~0: Flag to output input change (amount/rate) alarm of CH0 (highest/lowest)

								B	B	B	B	B	B	B	B0
								7	6	5	4	3	2	1	0
UXY.05								C	C	C	C	C	C	C	C
								H	H	H	H	H	H	H	H
								7	7	6	6	5	5	4	4

CH 0~7 alarm information
Bit ON (1): Alarm occurred
Bit Off (0): Normal

(6) Temperature-converted value (UXY.06 ~ UXY.13, X: Base No., Y: Slot No.)

(a) Temperature-converted value of each channel is output.

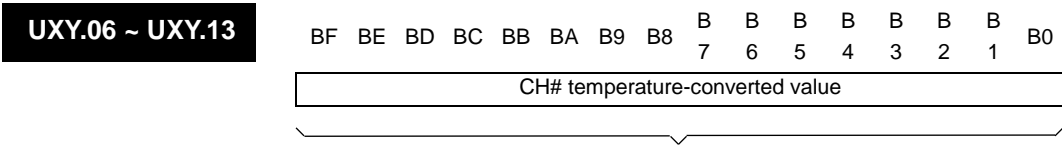

Address	Description
6	Channel 0 temperature-converted value
7	Channel 1 temperature-converted value
8	Channel 2 temperature-converted value
9	Channel 3 temperature-converted value
10	Channel 4 temperature-converted value
11	Channel 5 temperature-converted value
12	Channel 6 temperature-converted value
13	Channel 7 temperature-converted value

Output range of temperature value based on sensor type is as follows;

Sensor type	Digital output range	Valid Digital output range	Remark
PT100	2100 ~ 8600 (-210.0°C ~ 860.0°C)	2000 ~ 8500 (-200.0°C ~ 850.0°C)	
JPT100	-2100 ~ 6500 (-210.0°C ~ 650.0°C)	-2100 ~ 6400 (-200.0°C ~ 640.0°C)	

(7) Scaled calculation value (UXY.14 ~ UXY.21, X: Base No., Y: Slot No.)

(a) Scaled calculation value of each channel is output.

(b) Scaled calculation value is output within scale range of the max. value ~ the min. value (see operation parameters) which specifies temperature-converted value.(See Chapter 2 Specifications for details on its functions.)

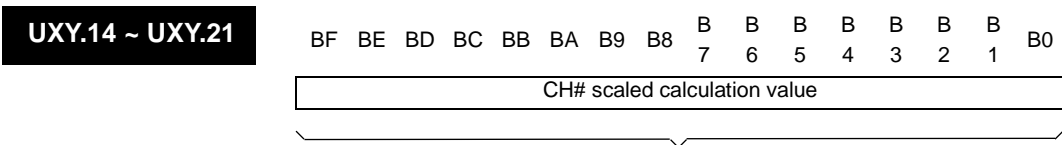

Address	Description
14	Channel 0 Scaled calculation value
15	Channel 1 Scaled calculation value
16	Channel 2 Scaled calculation value
17	Channel 3 Scaled calculation value
18	Channel 4 Scaled calculation value
19	Channel 5 Scaled calculation value
20	Channel 6 Scaled calculation value
21	Channel 7 Scaled calculation value

Chapter 5 Internal Memory Configuration and Function (For XGK)

(8) Command bit information (UXY.22.0, X: Base No., Y: Slot No.)

- (a) Bit F~4: Alarm function operates if the alarm output enabling bit of the applicable channel is set to 1.
- (b) Bit 3~0: Max/Min temperature-converted value is output when the command bit set for max/min. If command bit set to 0, min/max temperature-converted value do not display and current temperature-converted value displays

UXY.22.0~7	BF	BE	BD	BC	BB	BA	B9	B8	B	B	B	B	B	B	B	B0
									7	6	5	4	3	2	1	
	C	C	C	C	C	C	C	C	C	C	C	C	C	C	C	C
	H	H	H	H	H	H	H	H	H	H	H	H	H	H	H	H
	7	6	5	4	3	2	1	0	7	6	5	4	3	2	1	0

Alarm output enabling information of applicable channel
Bit ON (1): Enabled
Bit Off (0): Prohibited

Max/min temperature detection enabling information of applicable channel
Bit ON (1): Enabled
Bit Off (0): Prohibited

5.2.3 Operation Parameters Setting Area

- ▶ 2 word are assigned for each address in the internal memory, which can be displayed in 32 bits.
- ▶ If each bit of 32 bits configuring the address is On, let it set to “1”, and if it is Off, let it set to “0” so to realize the respective functions.

(1) Channel Enable/Disable (address No.0)

- (a) Temperature conversion can be set Enabled or Disabled for respective channels.
- (b) The conversion cycle can be reduced by setting to Disable the channel which will not be used.
- (c) If the channel to use is not specified, all the channels will be set to Disable.
- (d) Details for Enable/Disable conversion are described below.
- (e) Data of the channel unused (data read from PLC) will be all cleared to “0”.

Address 0

BF	BE	BD	BC	BB	BA	B9	B8	B7	B6	B5	B4	B3	B2	B1	B0
—	—	—	—	—	—	—	—	C	C	C	C	C	C	C	C
								H	H	H	H	H	H	H	H
								7	6	5	4	3	2	1	0

BIT	Description
0	Disable
1	Enable

- (f) The value specified in B8 ~ BF will be disregarded.
- (g) Use I/O parameter window for more convenient setting.

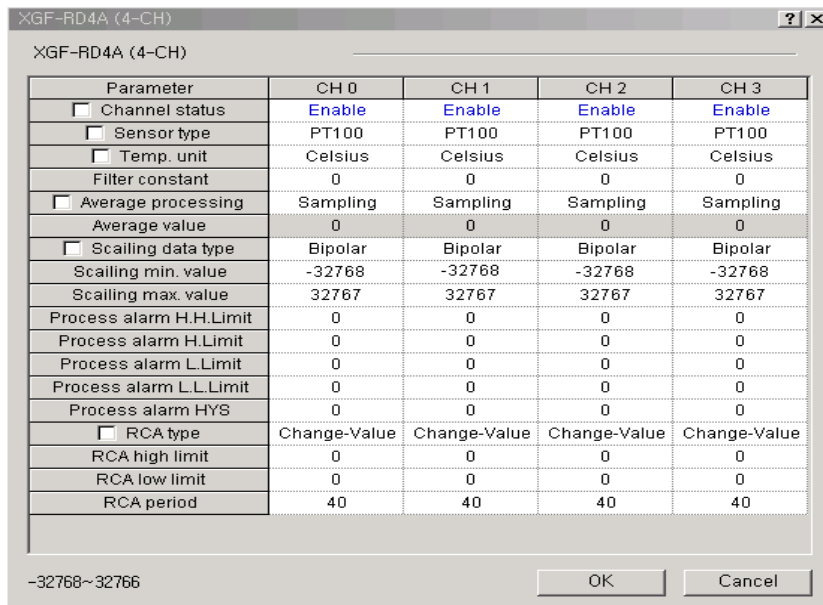

Chapter 5 Internal Memory Configuration and Function (For XGK)

(2) Sensor type setting (addresses 1~4)

(a) 2 types of RTD sensors are available for XGF-RD8A module.

(b) If 2 or more is input, setting error will occur (Uxy.01.8~Uxy.01.B) and the setting value will be "0"

Address 1~4

B1F	B1E	B1D	B1C	B1B	B1A	B19	B18	B17	B16	B15	B14	B13	B12	B11	B10
Channel 4~7 sensor type setting															

BF	BE	BD	BC	BB	BA0	B9	B8	B7	B6	B5	B4	B3	B2	B1	B0
Channel 0~3 sensor type setting															

Word value	Description
0	PT100
1	JPT100

(c) Use I/O parameter window for more convenient setting.

Parameter	CH 0	CH 1	CH 2	CH 3
<input type="checkbox"/> Channel status	Enable	Enable	Enable	Enable
<input checked="" type="checkbox"/> Sensor type	JPT100	JPT100	JPT100	JPT100
<input type="checkbox"/> Temp. unit	Celsius	Celsius	Celsius	Celsius
Filter constant	0	0	0	0
<input type="checkbox"/> Average processing	Sampling	Sampling	Sampling	Sampling
Average value	0	0	0	0
<input type="checkbox"/> Scalling data type	Bipolar	Bipolar	Bipolar	Bipolar
Scalling min. value	-32768	-32768	-32768	-32768
Scalling max. value	32767	32767	32767	32767
Process alarm H.H.Limit	0	0	0	0
Process alarm H.Limit	0	0	0	0
Process alarm L.Limit	0	0	0	0
Process alarm L.L.Limit	0	0	0	0
Process alarm HYS	0	0	0	0
<input type="checkbox"/> RCA type	Change-Value	Change-Value	Change-Value	Change-Value
RCA high limit	0	0	0	0
RCA low limit	0	0	0	0
RCA period	40	40	40	40

(3) Temperature conversion unit (address 5)

(a) Temperature-converted value can be output in °C or °F as specified.

Address 5

B1F	B1E	B1D	B1C	B1B	B1A	B19	B18	B17	B16	B15	B14	B13	B12	B11	B10
—	—	—	—	—	—	—	—	—	—	—	—	C	C	C	C
												H	H	H	H
												7	6	5	4
BF	BE	BD	BC	BB	BA	B9	B8	B7	B6	B5	B4	B3	B2	B1	B0
—	—	—	—	—	—	—	—	—	—	—	—	C	C	C	C
												H	H	H	H
												3	2	1	0

BIT	Description
0	Celsius
1	Fahrenheit

(b) Use I/O parameter window for more convenient setting.

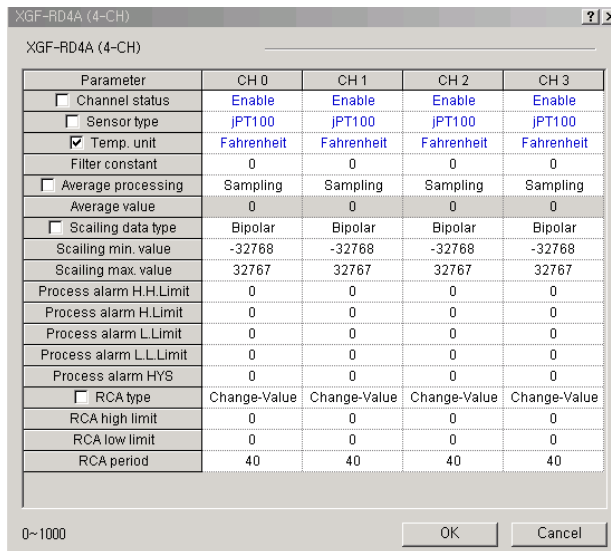

(4) Filter value (address 6 ~ 9)

- (a) If the filter value is set to “0”, the applicable channel will not be filtered but the sampled temperature-converted value will be output.
- (b) If set to “1 ~ 319” or “64001” or more, setting error will occur with the setting value of “0” internally produced.

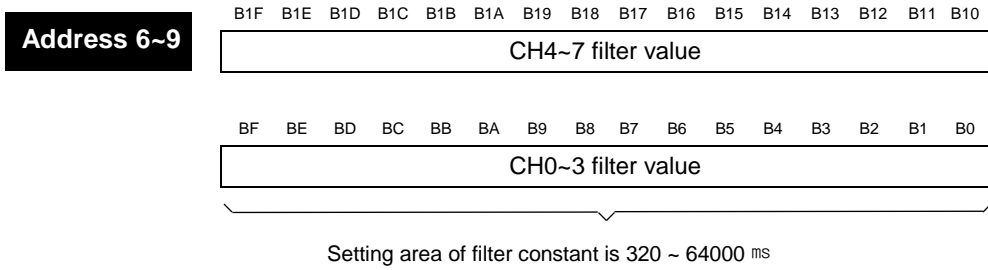

Address	Description
6	Channel 0 and 4 Filter Value Setting
7	Channel 1 and 5 Filter Value Setting
8	Channel 2 and 6 Filter Value Setting
9	Channel 3 and 7 Filter Value Setting

(c) Use I/O parameter window for more convenient setting.

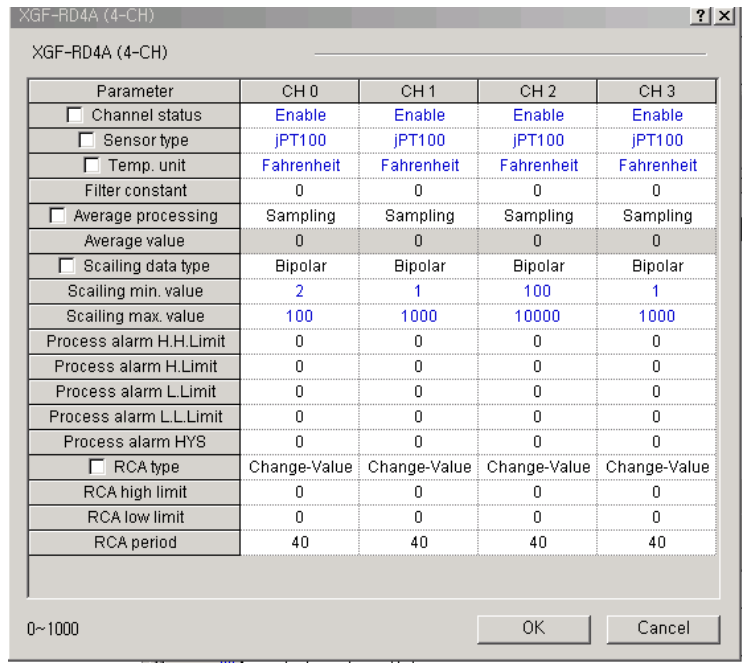

(5) Averaging process method (addresses 10~13)

(a) If set to "4" or more, setting error will occur with the setting value of "0" internally produced.

Address 10~13

B1F B1E B1D B1C B1B B1A B19 B18 B17 B16 B15 B14 B13 B12 B11 B10

CH4~7 filter value

BF BE BD BC BB BA B9 B8 B7 B6 B5 B4 B3 B2 B1 B0

CH0~3 filter value

BIT	Description
0	Sampling process
1	Time averaging process
2	Frequency averaging process
3	Movement averaging process

Address	Description
10	Channel 0 and 4 Averaging process method setting
11	Channel 1 and 5 Averaging process method setting
12	Channel 2 and 6 Averaging process method setting
13	Channel 3 and 7 Averaging process method setting

(b) Use I/O parameter window for more convenient setting.

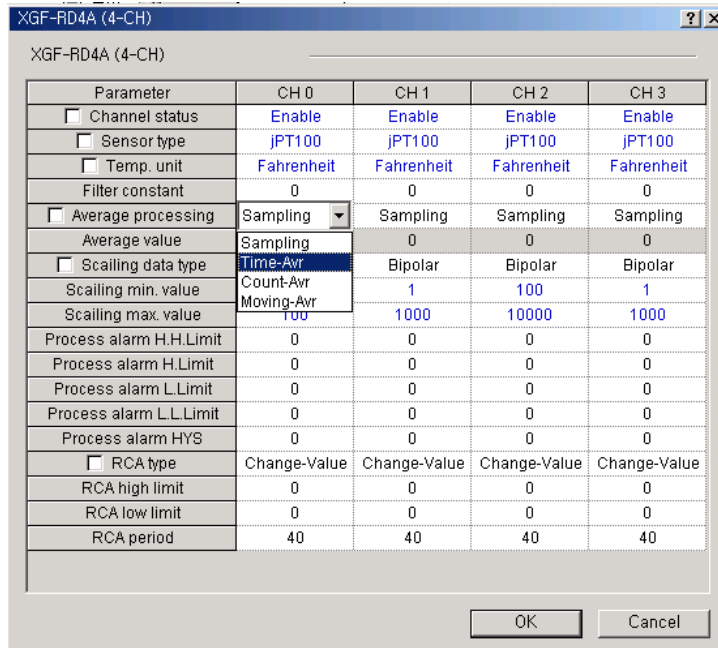

(6) Averaging value (address 14~17)

(a) If the averaging method is sampling, the setting value will be disregarded.

(b) If the averaging value is set exceeding the setting range, setting error will occur and the max/min averaging value will be specified.

Ex.) If Time average is selected with the average value of 200, setting error will occur with the setting value of "320" internally produced.

(c) However, if [I.O Parameter] is used, other value than the range can not be specified since inputting incorrect value is prohibited by package option. (If set incorrectly, it will be displayed in red with a resetting message)

Address 14~17

B1F B1E B1D B1C B1B B1A B19 B18 B17 B16 B15 B14 B13 B12 B11 B10

CH4~7 filter value

BF BE BD BC BB BA B9 B8 B7 B6 B5 B4 B3 B2 B1 B0

CH0~3 filter value

Average processing	Setting range
Time average	640~64000[ms]
Frequency average	2~64000[times]
Movement average	2~100[counts]

Address	Description
14	Channel 0 and 4 average value setting
15	Channel 1 and 5 average value setting
16	Channel 2 and 6 average value setting
17	Channel 3 and 7 average value setting

(d) Use I/O parameter window for more convenient setting.

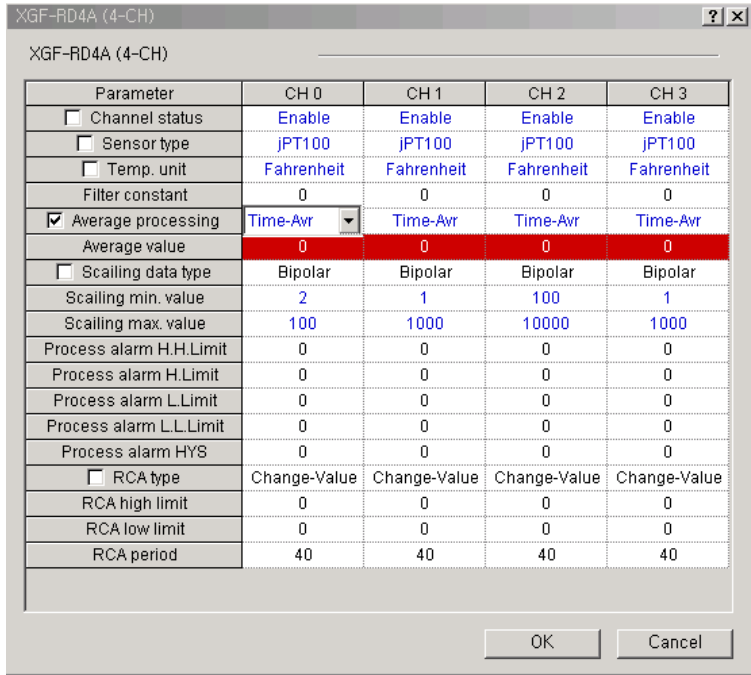

(7) Scaling data type (address 18)

- (a) If "1" is selected for the applicable bit, setting type of max/min scale range will be unsigned integer with the max. output data range of "0 ~ 65535" by scaled calculation.
- (b) If "0" is selected for the applicable bit, setting type of max/min scale range will be signed integer with the max. output data range of "-32768 ~ 32767" by scaled calculation (default).
- (c) Information specified in Bits "4~F" will be disregarded.

Address 18	B1F	B1E	B1D	B1C	B1B	B1A	B19	B18	B17	B16	B15	B14	B13	B12	B11	B10
	—	—	—	—	—	—	—	—	—	—	—	—	C	C	C	C
													H	H	H	H
													7	6	5	4
	BF	BE	BD	BC	BB	BA	B9	B8	B7	B6	B5	B4	B3	B2	B1	B0
	—	—	—	—	—	—	—	—	—	—	—	—	C	C	C	C
													H	H	H	H
													3	2	1	0

BIT	Description
0	Set to signed integer scale range
1	Set to unsigned integer scale range

(d) Use I/O parameter window for more convenient setting.

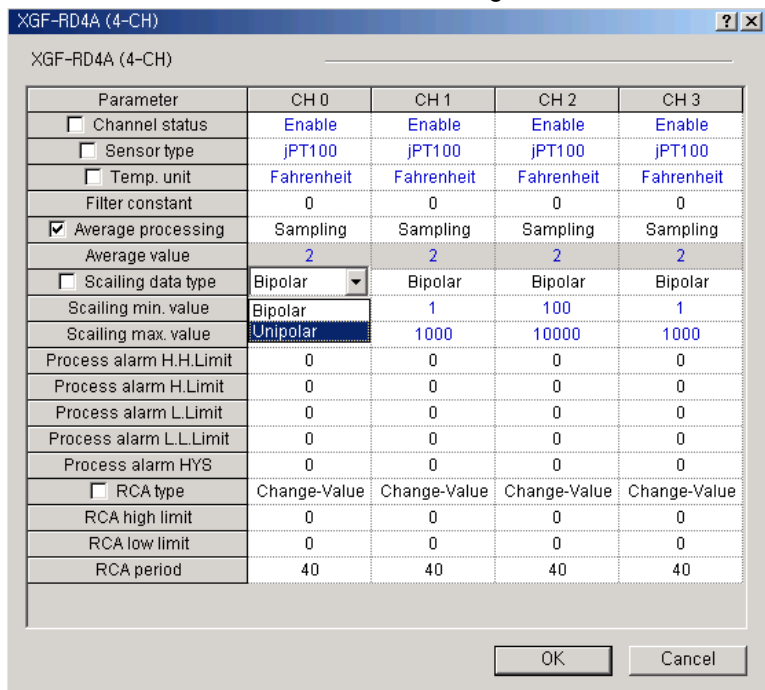

* Bipolar: output data in the positive/negative poles (+/-) of value (Signed Integer).
 Unipolar: output data in the positive pole (+) of value (Unsigned Integer).

(8) Scaling range (address 19~26)

(a) If scale value is setting out of scaling range, setting error will occur and the setting value saved internal memory is kept.

Address 19~26

B1F B1E B1D B1C B1B B1A B19 B18 B17 B16 B15 B14 B13 B12 B11 B10	CH4~7 filter value
BF BE BD BC BB BA B9 B8 B7 B6 B5 B4 B3 B2 B1 B0	CH0~3 filter value

Type	Setting range
Signed type	-32768 ~ 32767
Unsigned type	0 ~ 65535

Address	Description
19	Channel 0 and 4 scaling range minimum value setting
20	Channel 0 and 4 scaling range maximum value setting
21	Channel 1 and 5 scaling range minimum value setting
22	Channel 1 and 5 scaling range maximum value setting
23	Channel 2 and 6 scaling range minimum value setting
23	Channel 2 and 6 scaling range maximum value setting
25	Channel 3 and 7 scaling range minimum value setting
26	Channel 3 and 7 scaling range maximum value setting

(b) Use I/O parameter window for more convenient setting.

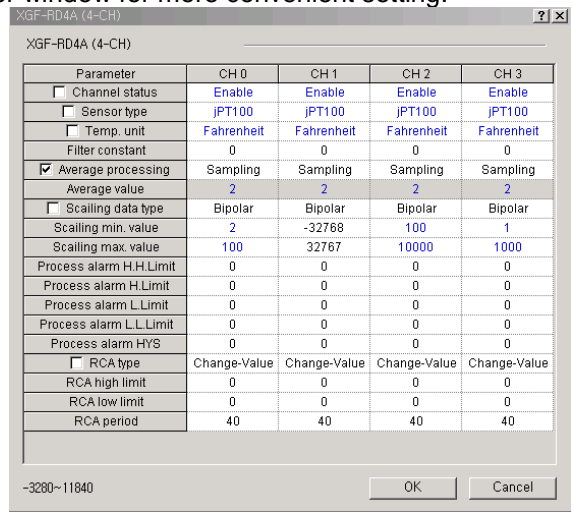

(9) Process alarm limit value (address 27~42)

- (a) Setting range can be specified individually based on the type of output temperature (°C /°F) and the type of sensor (Pt100/JPt100).
- (b) If a value other than range is set, setting error will occur with the setting value saved inside the module as kept.

Address 27~42 B1F B1E B1D B1C B1B B1A B19 B18 B17 B16 B15 B14 B13 B12 B11 B10

CH4~7 filter value

BF BE BD BC BB BA B9 B8 B7 B6 B5 B4 B3 B2 B1 B0

CH0~3 filter value

Sensor type and Temperature conversion unit		Setting range
PT100	Celsius	-2000 ~ 8500
	Fahrenheit	-3280 ~ 15620
JPT100	Celsius	-2000 ~ 6400
	Fahrenheit	-3280 ~ 11840

Address	Description
27	Channel 0 and 4 Process Alarm High-High value Setting
28	Channel 0 and 4 Process Alarm High value Setting
29	Channel 0 and 4 Process Alarm Low value Setting
30	Channel 0 and 4 Process Alarm Low Low value Setting
31	Channel 1 and 5 Process Alarm High-High value Setting
32	Channel 1 and 5 Process Alarm High value Setting
33	Channel 1 and 5 Process Alarm Low value Setting
34	Channel 1 and 5 Process Alarm Low Low value Setting
35	Channel 2 and 6 Process Alarm High-High value Setting
36	Channel 2 and 6 Process Alarm High value Setting
37	Channel 2 and 6 Process Alarm Low value Setting
38	Channel 2 and 6 Process Alarm Low Low value Setting
39	Channel 3 and 7 Process Alarm High-High value Setting
40	Channel 3 and 7 Process Alarm High value Setting
41	Channel 3 and 7 Process Alarm Low value Setting
42	Channel 3 and 7 Process Alarm Low Low value Setting

(c) Use I/O parameter window for more convenient setting.

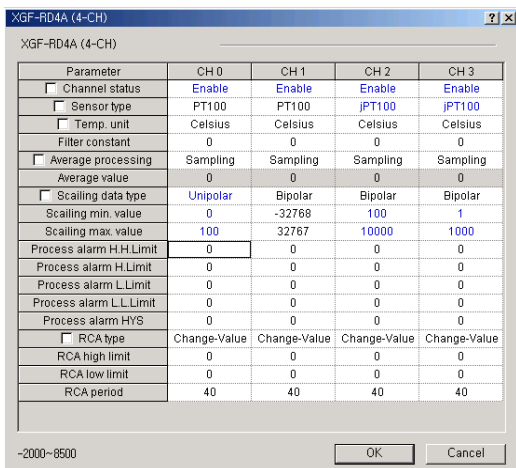

(10) Process alarm hysteresis (address 43~46)

- (a) If a value other than range is set, setting error will occur with the setting value of "0" saved inside the module as kept.
- (b) If process alarm function is used, the alarm output will be kept if set within the hysteresis value although the alarming condition is cancelled.

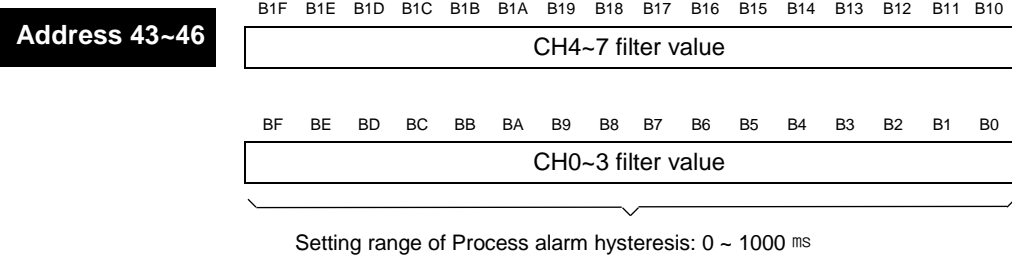

Address	Description
43	Channel 0 and 4 Process Alarm Hysteresis Setting
44	Channel 1 and 5 Process Alarm Hysteresis Setting
45	Channel 2 and 6 Process Alarm Hysteresis Setting
46	Channel 3 and 7 Process Alarm Hysteresis Setting

- (c) Use I/O parameter window for more convenient setting.

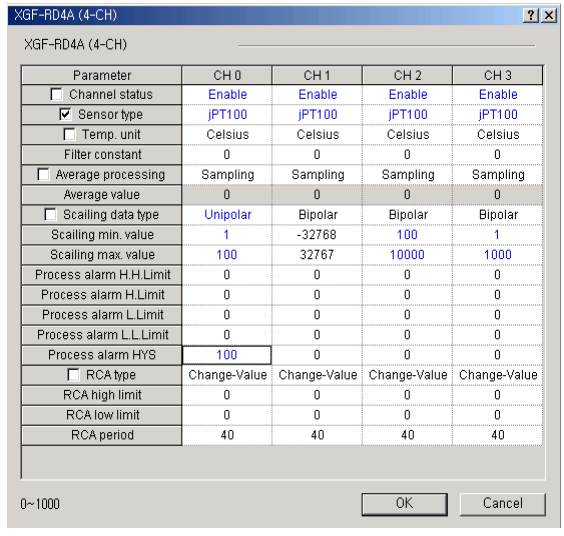

(11) Change rate alarm type (address 47)

(a) If the applicable bit is set to "1", change rate is the criterion of alarm for applicable channel (rate for input range based on the sensor type).

Ex.) As for Pt100,

$$\text{Variation rate} = (\text{Present temperature value} - \text{Temperature value prior to alarm}) * 100 / (8500 - (-2000))$$

(b) If set to "0", the Temperature-converted value itself is criterion of alarm.

(c) The information specified in Bits 4 ~ F will be disregarded.

Address 47

B1F	B1E	B1D	B1C	B1B	B1A	B19	B18	B17	B16	B15	B14	B13	B12	B11	B10
—	—	—	—	—	—	—	—	—	—	—	—	C	C	C	C
												H	H	H	H
												7	6	5	4

BF	BE	BD	BC	BB	BA	B9	B8	B7	B6	B5	B4	B3	B2	B1	B0
—	—	—	—	—	—	—	—	—	—	—	—	C	C	C	C
												H	H	H	H
												3	2	1	0

BIT	Description
0	Temperature-converted value
1	Temperature-converted rate

(d) Use I/O parameter window for more convenient setting.

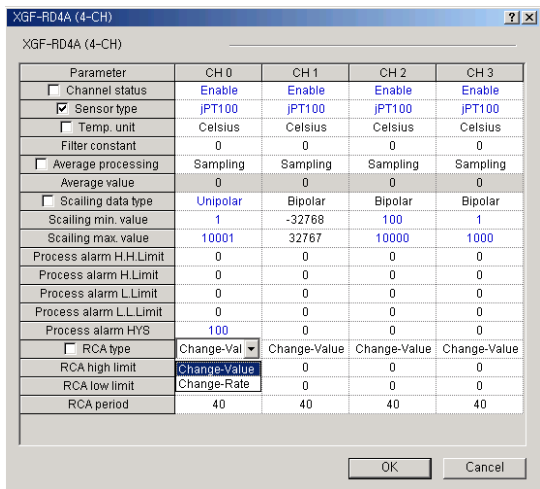

(12) Change rate alarm Max./Min. value (address 48~55)

- (a) If a value other than range is set, setting error will occur with the setting value of "0" saved inside the module.
- (b) In case of temperature change rate, it will be a percentage value of temperature change rate specifying to the first decimal point.
- (c) In case of temperature change value, the unit of the value to be set in this area represents temperature

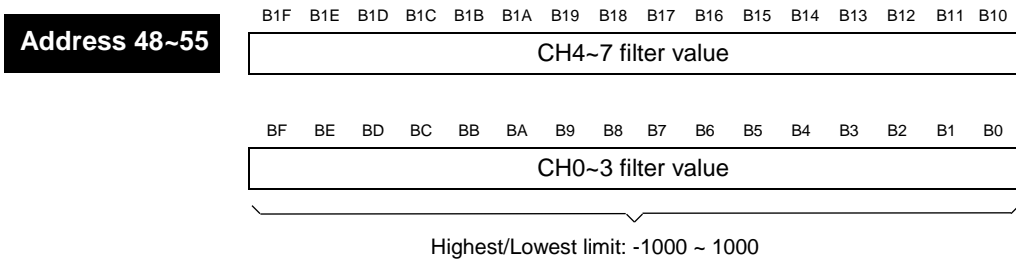

Address	Description
48	Channel 0 and 4 Input Variation Alarm Upper Limit Value Setting
49	Channel 0 and 4 Input Variation Alarm Lower Limit Value Setting
50	Channel 1 and 5 Input Variation Alarm Upper Limit Value Setting
51	Channel 1 and 5 Input Variation Alarm Lower Limit Value Setting
52	Channel 2 and 6 Input Variation Alarm Upper Limit Value Setting
53	Channel 2 and 6 Input Variation Alarm Lower Limit Value Setting
54	Channel 3 and 7 Input Variation Alarm Upper Limit Value Setting
55	Channel 3 and 7 Input Variation Alarm Lower Limit Value Setting

(d) Use I/O parameter window for more convenient setting.

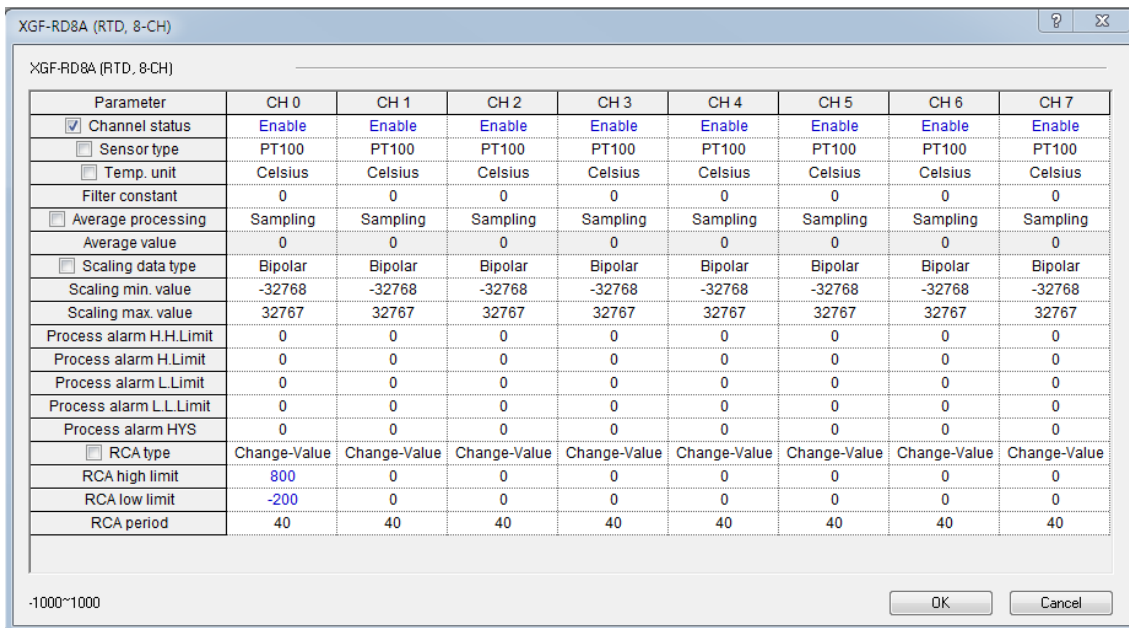

(13) Detection cycle of input variation alarm (address 56~59)

- (a) It is used to specify the detection cycle of input variation, if input variation alarming function is used.
- (b) If a value other than range is set, setting error will occur with the setting value of "40" saved inside the module as kept.

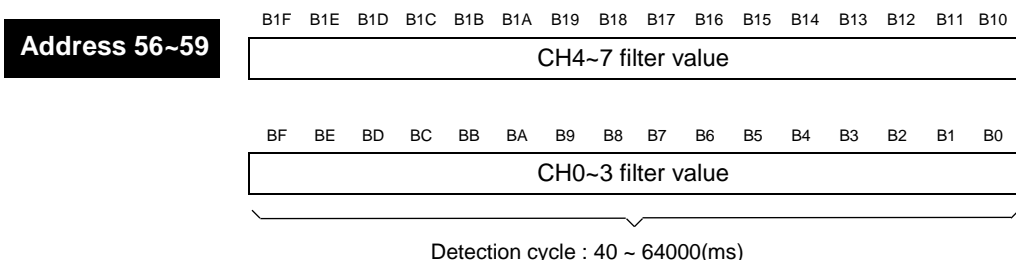

Address	Description
56	Channel 0 and 4 Change Rate Alarm Detection Cycle Setting
57	Channel 1 and 5 Change Rate Alarm Detection Cycle Setting
58	Channel 2 and 6 Change Rate Alarm Detection Cycle Setting
59	Channel 3 and 7 Change Rate Alarm Detection Cycle Setting

- (c) Use I/O parameter window for more convenient setting.

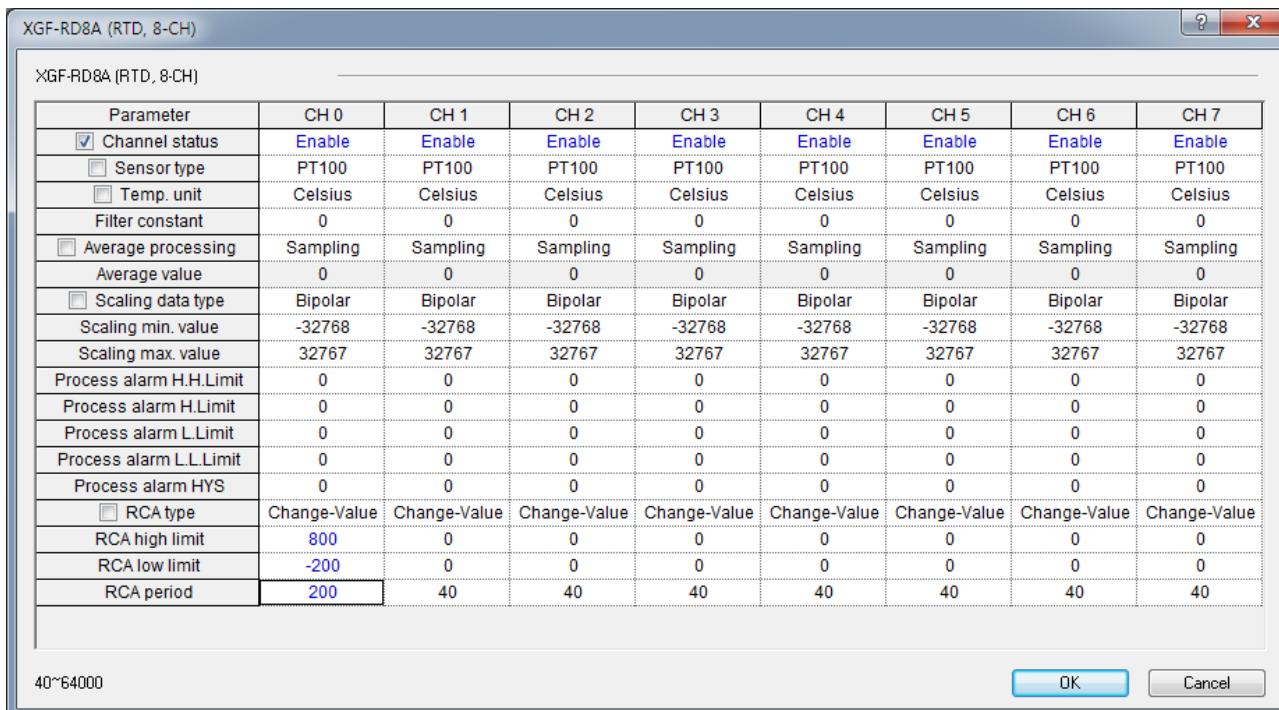

(14) Setting error information (address 60~63)

- (a) If a value other than range is set (in the PLC program), “1” will be output to the applicable bit.
- (b) Setting error can be reset if a value in normal range is input.
- (c) There will be no change in the module LED when setting error occurs. If more than 1 bits of Uxy.01.08~Uxy.01.0D turned on, check this area and its settings.
- (d) Error details and setting address of applicable bits.
 - Bit 0: Setting error of CH sensor type (address 1~4)
 - Bit 1: Setting error of CH filter value (address 6~9)
 - Bit 2: Setting error of CH averaging type (address 10~13)
 - Bit 3: Setting error of CH averaging value (address 14~17)
 - Bit 4: Setting error of CH scale min. range (address 19, 21, 23, 25)
 - Bit 5: Setting error of CH scale max. range (address 20, 22, 24, 26)
 - Bit 6: Setting error of CH process alarm High High value (address 27,31,35,39)
 - Bit 7: Setting error of CH process alarm High value (address 28, 32, 36, 40)
 - Bit 8: Setting error of CH process alarm Low value (address 29, 33, 37, 41)
 - Bit 9: Setting error of CH process alarm Low Low value (address 30, 34, 38, 42)
 - Bit A: Setting error of CH process alarm hysteresis (address 39~46)
 - Bit B: Setting error of CH input variation alarm Max. value (address 48, 50, 52, 54)
 - Bit C: Setting error of CH input variation alarm Min. value (address 49, 51, 53, 55)
 - Bit D: Setting error of CH input variation alarm detection cycle (address 56~59)

Address 60~63

B1F	B1E	B1D	B1C	B1B	B1A	B19	B18	B17	B16	B15	B14	B13	B12	B11	B10
—	—	—	C	C	C	C	C	C	C	C	C	C	C	C	C
			H	H	H	H	H	H	H	H	H	H	H	H	H
			4	4	4	4	4	4	4	4	4	4	4	4	4

BF	BE	BD	BC	BB	BA	B9	B8	B7	B6	B5	B4	B3	B2	B1	B0
—	—	—	C	C	C	C	C	C	C	C	C	C	C	C	C
			H	H	H	H	H	H	H	H	H	H	H	H	H
			0	0	0	0	0	0	0	0	0	0	0	0	0

Address	Description
60	Channel 0 and 4 Setting Error Information Output
61	Channel 1 and 5 Setting Error Information Output
62	Channel 2 and 6 Setting Error Information Output
63	Channel 3 and 7 Setting Error Information Output

- (15) Change value(change rate) output of Change rate alarm (address 64~67)
- (a) The amount of changes in input temperature or change rate (rate % based on the sensor range) is saved every detection cycle of input variation alarm specified in the address of 56~59.
 - (b) Monitoring with [Special module monitoring] is also available.

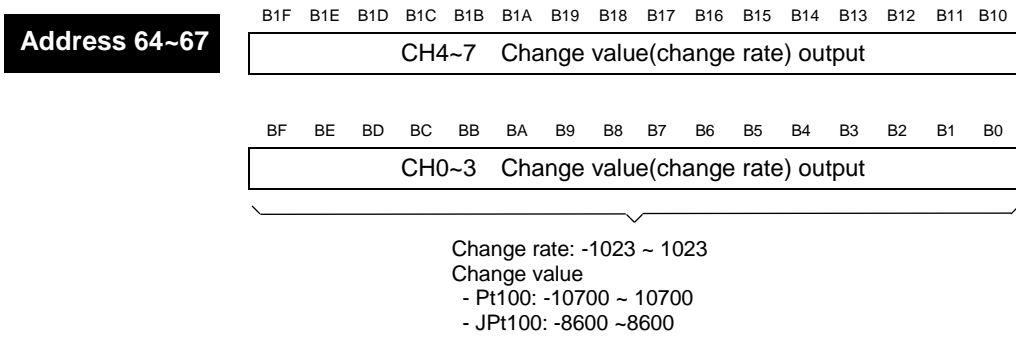

Address	Description
64	Channel 0 and 4 Change Value (Change Rate) Output of Change rate alarm
65	Channel 1 and 5 Change Value (Change Rate) Output of Change rate alarm
66	Channel 2 and 6 Change Value (Change Rate) Output of Change rate alarm
67	Channel 3 and 7 Change Value (Change Rate) Output of Change rate alarm

- (c) In order to monitor the change value (change rate) of change rate alarm, open FLAG monitoring window and set the alarm operation Enabled also on the [Special module monitoring] window.

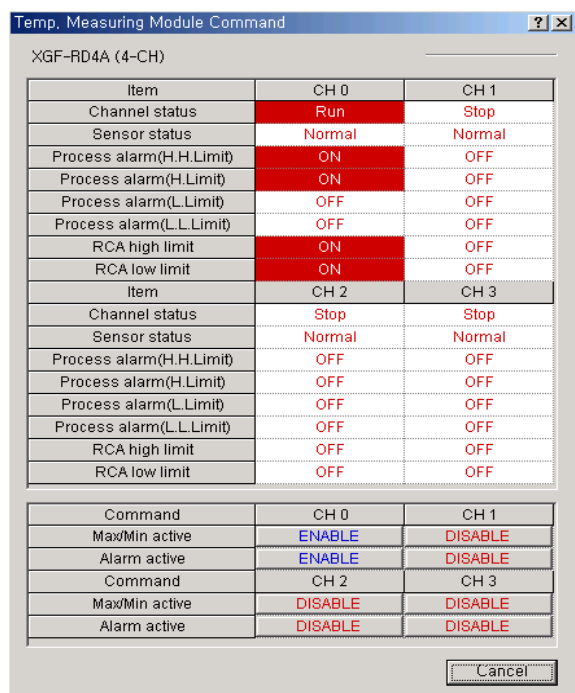
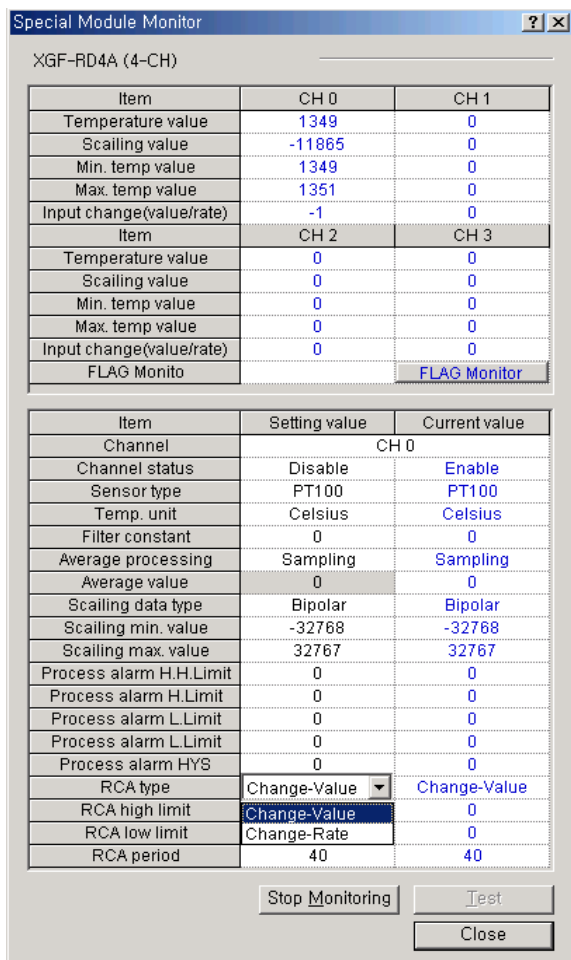

- (16) Sensor disconnection information (address 68~71)
 (a) It is used to output the disconnection information.

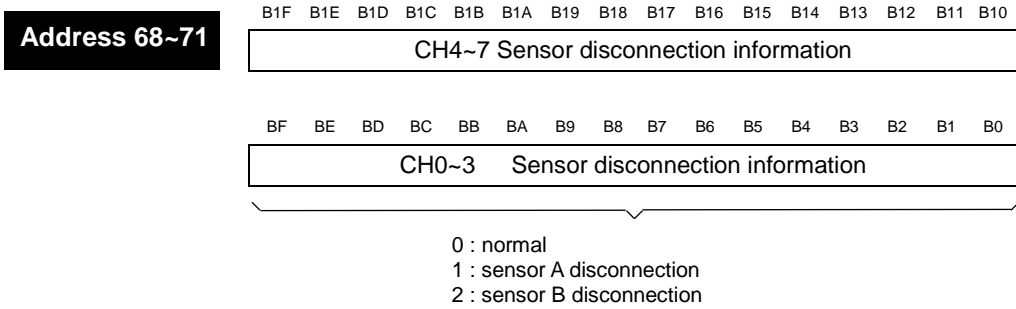

Address	Description
68	Channel 0 and 4 Sensor Disconnection Information Output
69	Channel 1 and 5 Sensor Disconnection Information Output
70	Channel 2 and 6 Sensor Disconnection Information Output
71	Channel 3 and 7 Sensor Disconnection Information Output

- (17) Temperature-converted min/max value (address 72~79)
 (b) If command bit information (UXY.22.0) is set to 1, temperature-converted min/max value are displayed.

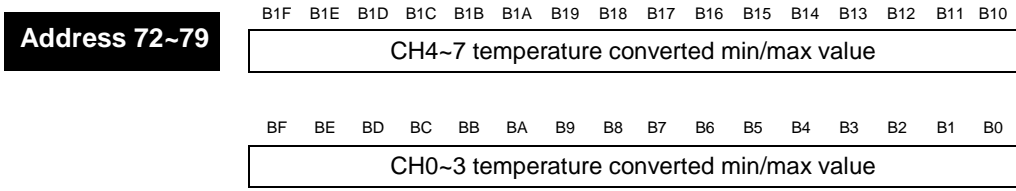

Address	Description
72	Channel 0 and 4 temperature converted min value
73	Channel 0 and 4 temperature converted max value
74	Channel 1 and 5 temperature converted min value
75	Channel 1 and 5 temperature converted max value
76	Channel 2 and 6 temperature converted min value
77	Channel 2 and 6 temperature converted max value
78	Channel 3 and 7 temperature converted min value
79	Channel 3 and 7 temperature converted max value

(18) Data Upload time (address 80~87)

- (a) When updating module data sharing with XGT PLC, Update interval time is display
The unit of data upload time is 0.1ms.
- (b) Using temperature-converted value for temperature control, Upload time is used to decide control period. (Refer to chapter 2)

Address 80~87

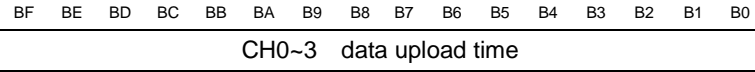
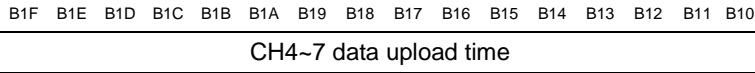

Address	Description
80	Channel 0 and 4 data upload time
81	
82	Channel 1 and 5 data upload time
83	
84	Channel 2 and 6 data upload time
85	
86	Channel 3 and 6 data upload time
87	

(19) User offset/gain mode channel setting (address 128)

- (a) If the applicable bit is set to "1", enable user offset/gain mode to start.
- (b) If channel is not set user offset/gain, factory set offset/gain values are operating.
- (c) When the module is under the user offset/gain enable mode and then channels are permitted to operation mode, temperature-converted value are display.

Address 128

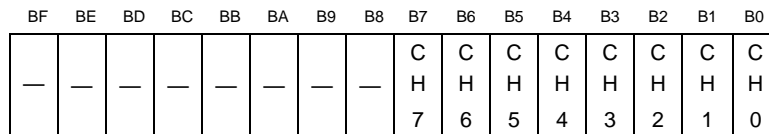

BIT	Description
0	Disable
1	Enable

(20) User offset/gain mode type (address 129)

- (a) In user offset/gain mode, use this area to select setting lower limit value or setting upper limit value.
- (b) If is not designated, default value is setting to lower limit value.

Address 129	BF	BE	BD	BC	BB	BA	B9	B8	B7	B6	B5	B4	B3	B2	B1	B0
	—	—	—	—	—	—	—	—	C	C	C	C	C	C	C	C
									H	H	H	H	H	H	H	H
									7	6	5	4	3	2	1	0

BIT	Description
0	Lower limit setting
1	Upper limit setting

(21) User offset/gain mode request (address 130)

- (a) In user offset/gain mode, use this area to select user offset/gain mode start or stop.
- (b) If is not designated, default value is setting to stop.

Address 130	BF	BE	BD	BC	BB	BA	B9	B8	B7	B6	B5	B4	B3	B2	B1	B0
	—	—	—	—	—	—	—	—	C	C	C	C	C	C	C	C
									H	H	H	H	H	H	H	H
									7	6	5	4	3	2	1	0

BIT	Description
0	Stop
1	Start

(22) User offset/gain mode completed (address 131)

- (a) In user offset/gain mode, use this area to select user offset/gain mode completed or stop.
- (b) If is not designated, default value is setting to uncompleted.

Address 131	BF	BE	BD	BC	BB	BA	B9	B8	B7	B6	B5	B4	B3	B2	B1	B0
	—	—	—	—	—	—	—	—	C	C	C	C	C	C	C	C
									H	H	H	H	H	H	H	H
									7	6	5	4	3	2	1	0

BIT	Description
0	Uncompleted
1	Completed

(23) User offset value (address 132~135)

(a) Saving offset value in user offset/gain mode.

If offset value set to 100℃, save the value to 1000.

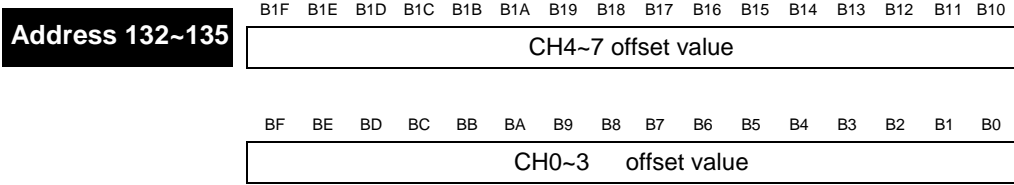

Address	Description
132	Channel 0 and 4 offset value
133	Channel 1 and 5 offset value
134	Channel 2 and 6 offset value
135	Channel 3 and 6 offset value

(24) User offset/gain value (address 140~143)

(a) Saving gain value in user offset/gain mode.

If gain value set to 500℃, it displays 5000.



Address	Description
140	Channel 0 and 4 gain value
141	Channel 1 and 5 gain value
142	Channel 2 and 6 gain value
143	Channel 3 and 6 gain value

(25) User offset and gain mode write (address 148~151)

- (a) Write offset and gain value save command to internal memory of offset and gain mode
- (b) If saving offset/gain values, temperature-converted values are also changed according to user offset/gain values .

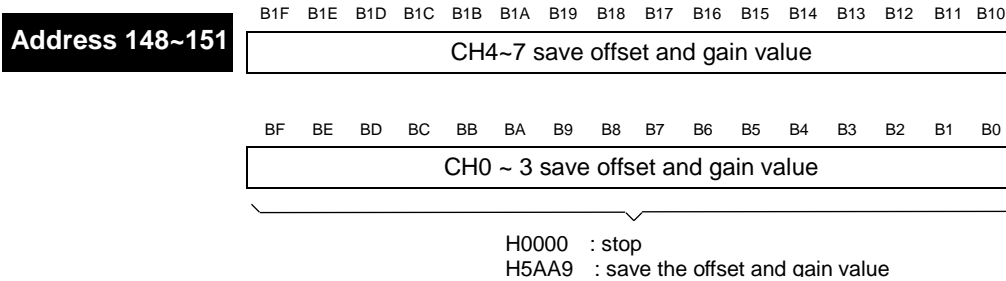

Address	Description
148	Channel 0 and 4 offset and gain value save command
149	Channel 1 and 5 offset and gain value save command
150	Channel 2 and 6 offset and gain value save command
151	Channel 3 and 6 offset and gain value save command

(26) Error code in user offset and gain mode (address 156~159)

- (a) Save error code in user offset and gain mode. Description of error codes are explained below

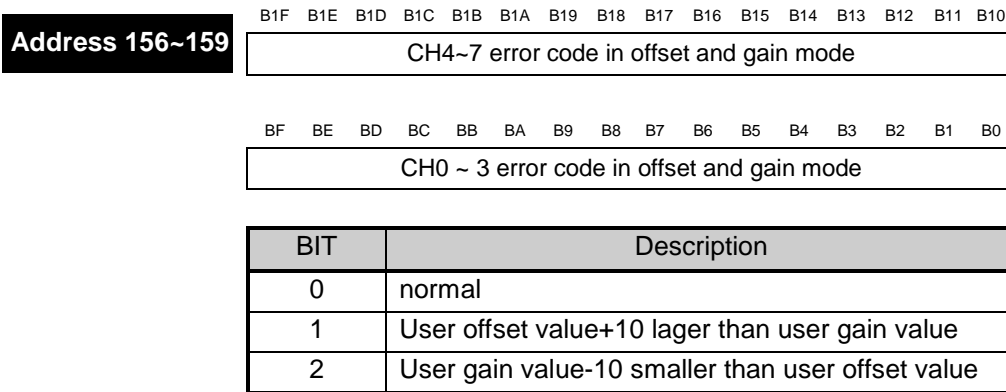

Address	Description
156	Channel 0 and 4 error code in offset and gain mode
157	Channel 1 and 5 error code in offset and gain mode
158	Channel 2 and 6 error code in offset and gain mode
159	Channel 3 and 6 error code in offset and gain mode

(27) User offset and gain data move start command for on-line module change (address 192)

- (a) Save command of user offset and gain after on-line module change
- (b) Save offset and gain value to changed module using on-line module change.

Before this command, on-line module change should be completed.

Refer to appendix 3

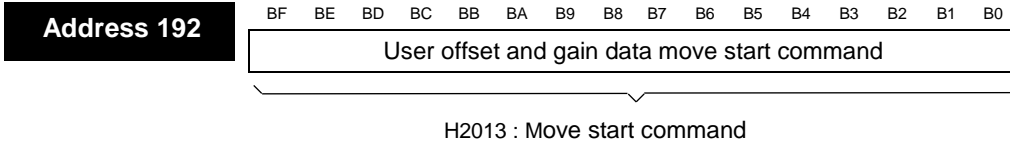

(28) Save completion of user offset and gain value for on-line module change (address 196)

- (a) Monitor save completion of user offset and gain value from CPU module to changed module using on-line module change function.

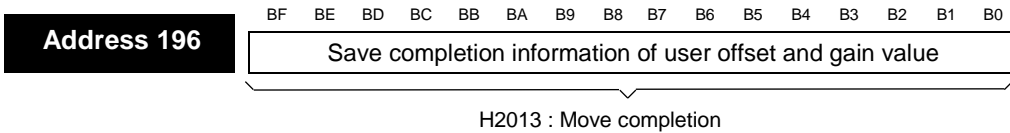

(29) User offset value for on-line module change (address 200~203)

- (a) In user offset value before the module change for on-line module change.

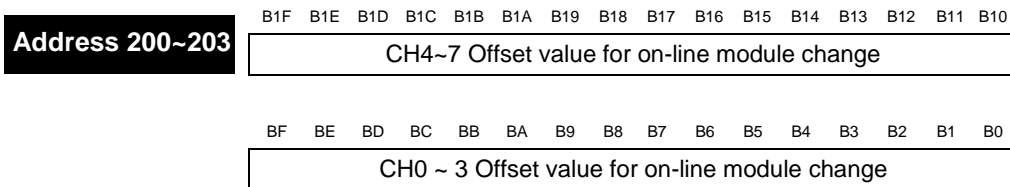

Address	Description
200	Channel 0 and 4 offset value for on-line module change
201	Channel 1 and 5 offset value for on-line module change
202	Channel 2 and 6 offset value for on-line module change
203	Channel 3 and 7 offset value for on-line module change

(30) User gain value for on-line module change (address 204~207)

(a) In user gain value before the module change for on-line module change.

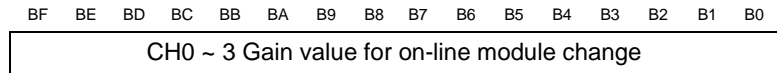
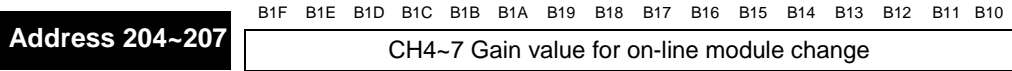

Address	Description
204	Channel 0 and 4 gain value for on-line module change
205	Channel 1 and 5 gain value for on-line module change
206	Channel 2 and 6 gain value for on-line module change
207	Channel 3 and 7 gain value for on-line module change

(31) Upload offset value for on-line module change (address 230~233)

(a) The upload offset values use to save user offset value to changed module for on-line module change.

(b) To save offset values to changed module, the upload offset values are saved to user program before on-line module change.

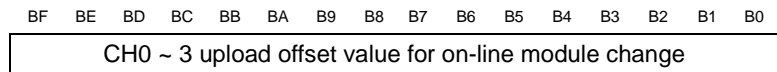
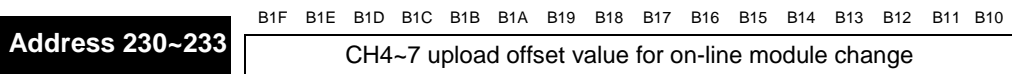

Address	Description
204	Channel 0 and 4 gain value for on-line module change
205	Channel 1 and 5 gain value for on-line module change
206	Channel 2 and 6 gain value for on-line module change
207	Channel 3 and 7 gain value for on-line module change

(32) Upload gain value for on-line module change (address 234~237)

(a) The upload gain values use to save user gain value to changed module for on-line module change.

(b) To save gain values to changed module, the upload gain values are saved to user program before on-line module change.

Address 234~237

B1F B1E B1D B1C B1B B1A B19 B18 B17 B16 B15 B14 B13 B12 B11 B10
 CH4~7 upload gain value for on-line module change

BF BE BD BC BB BA B9 B8 B7 B6 B5 B4 B3 B2 B1 B0
 CH0 ~ 3 upload gain value for on-line module change

Address	Description
204	Channel 0 and 4 gain value for on-line module change
205	Channel 1 and 5 gain value for on-line module change
206	Channel 2 and 6 gain value for on-line module change
207	Channel 3 and 7 gain value for on-line module change

Chapter 6 Programming (For XGK)

6.1 XGF-RD4A/ XGF-RD4S

6.1.1 Read/Write of Operation Parameters Setting Area

It describes the basis of the XGF-RD4A module about configuration of the internal memory.

(1) Read of operation parameters setting area (GET, GETP command)

Command	Available area														Step	Flag		
	PMK	F	L	T	C	S	Z	D.x	R.x	상수	U	N	D	R		Error (F110)	Zero (F111)	Carry (F112)
GET(P)	sl	-	-	-	-	-	-	-	-	-	○	-	-	-	4~7	-	-	-
	S	-	-	-	-	-	-	-	-	-	○	-	-	-				
	D	○	-	○	-	-	-	-	-	-	-	○	○	○				
	N	○	-	○	-	-	-	-	-	-	○	○	○	○				

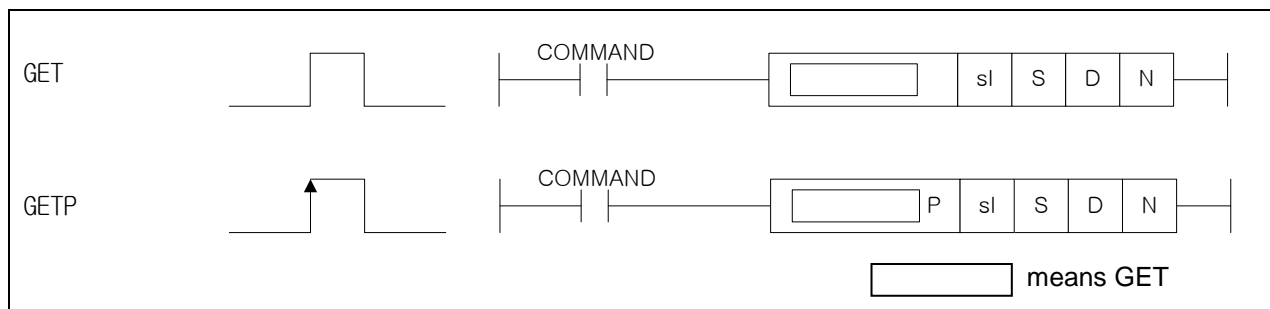

[Setting area]

Operand	Description	Data size
sl	Slot No. where special module is installed on	WORD
S	Start address of internal memory of special module to read.	WORD
D	Start memory address of CPU module where the read data will be saved in.	WORD
N	Number of words data to read	WORD

[Flag set]

Flag	Description	Device No.
PUT/GET Error	- In case special module does not exist in the specified slot - In case that it does not properly execute PUT/GET command	F0015~F0022

Ex. If RTD module is installed on Base No.0 and Slot No.3, and the data of internal memory addresses No.0 & 1's in RTD modules are read and saved in D0 and D1 of CPU module while M00000 bit turned on.

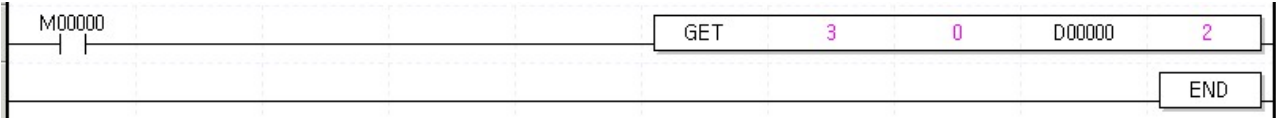
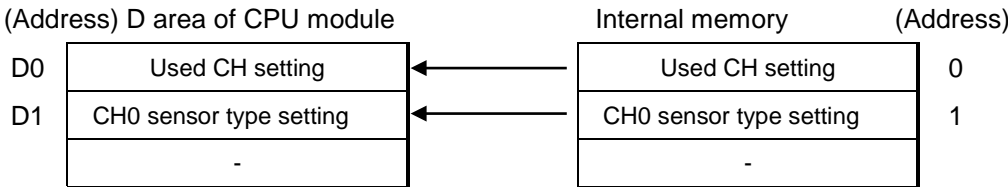

(2) Write of operation parameters setting area (PUT, PUTP command)

Command	Available area														Step	Flag			
	PMK	F	L	T	C	S	Z	D.x	R.x	Constant	U	N	D	R		Error (F110)	Zero (F111)	Carry (F112)	
PUT(P)	sl	-	-	-	-	-	-	-	-	-	○	-	-	-	-	4~7	-	-	-
	S	-	-	-	-	-	-	-	-	-	○	-	-	-	-				
	D	○	-	○	-	-	-	-	-	-	○	○	○	○	○				
	N	○	-	○	-	-	-	-	-	-	○	○	○	○	○				

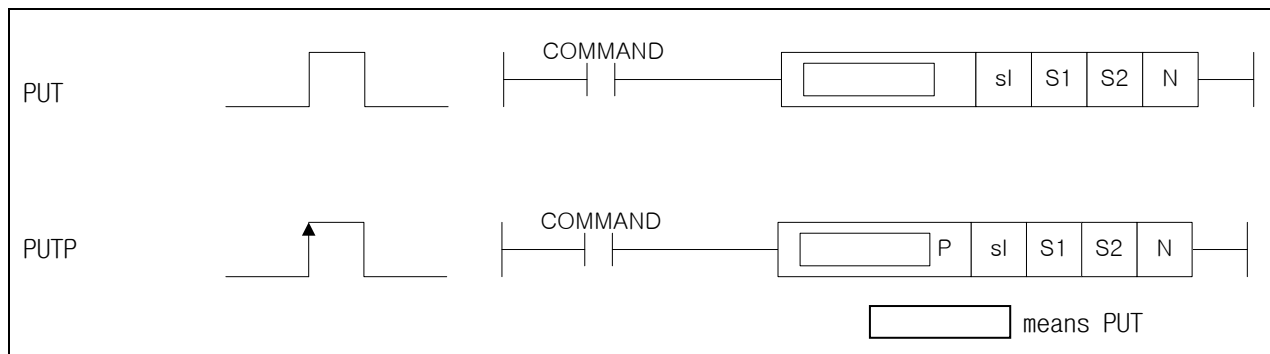

[Setting area]

Operand	Description	Data size
sl	Slot No. where special module is installed on	WORD
S1	Start address of internal memory of special module to write data	WORD
S2	Start memory address of CPU module where the data to write is saved in	WORD
N	Number of words data to write	WORD

[Flag set]

Flag	Description	Device No.
PUT/GET Error	- In case special module does not exist in the specified slot - In case that it does not properly execute PUT/GET command	F0015~F0022

Ex. If RTD module is installed on Base No.0 and Slot No.6, and CPU module's data of D10~D13 is written on internal memory addresses 14~17 of RTD input module while M00000 bit turned on.

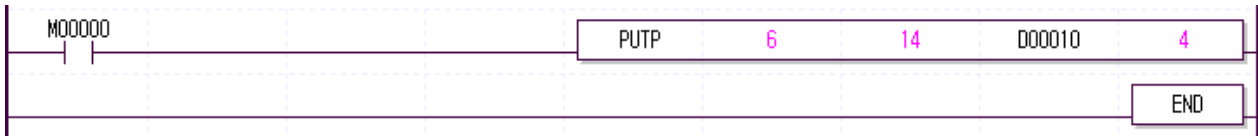
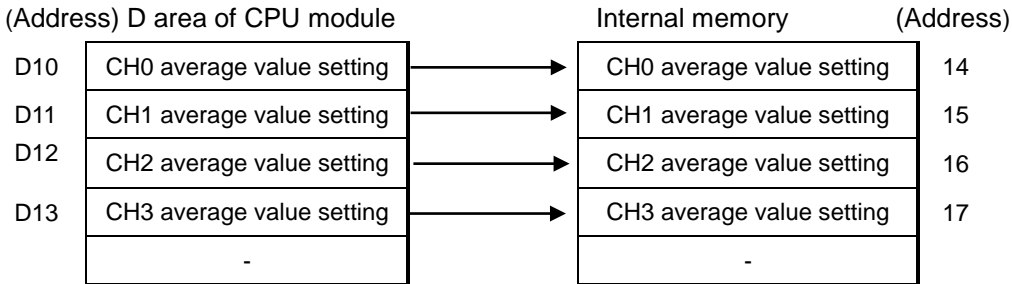

6.1.2 Basic Program

- How to specify operation condition details of RTD input module's internal memory is described.
- RTD module is assumed to be installed on Slot 2.
- Assigned I/O points of RTD module is 16 points when 'Assign fixed points to I/O slot (64)' option in the basic parameter is not used.
- The setting values specified in the [I/O Parameter] will be saved on the RTD module one time when the parameter is downloaded and the module is initialized.

(1) Program example through [I/O parameters] setting

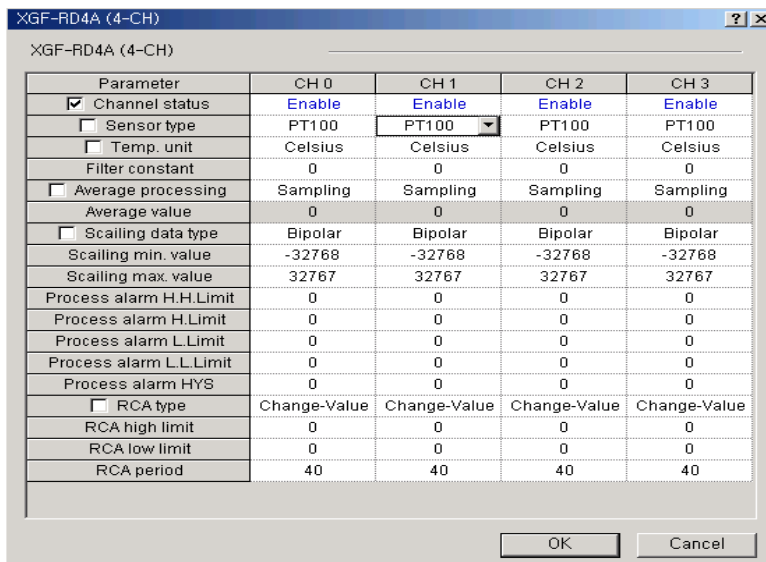
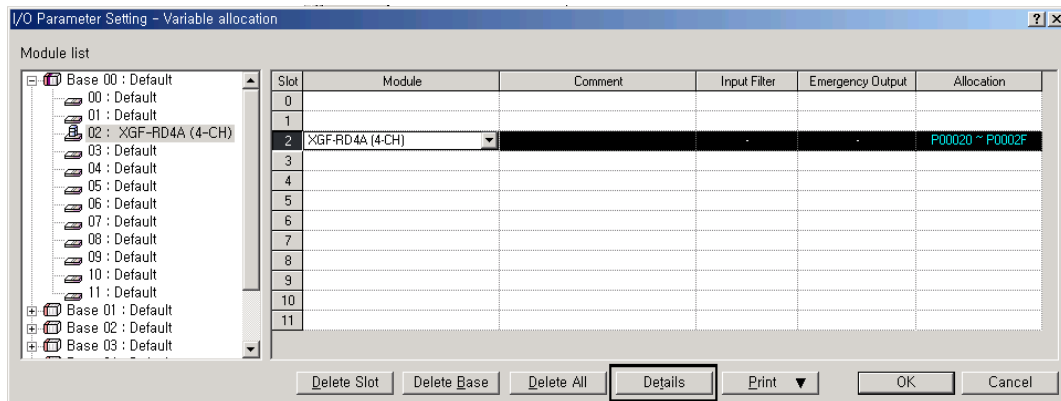

► Register the applicable module in the slot where the module is installed on ,and specify the operation parameters to download to PLC.

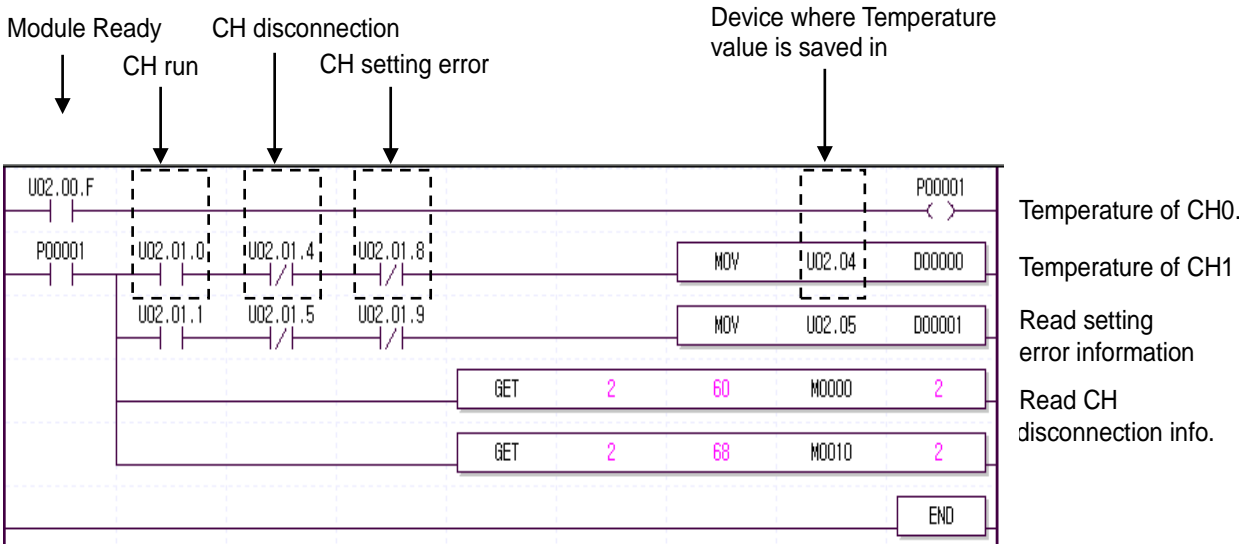

(2) Program example using PUT/GET command

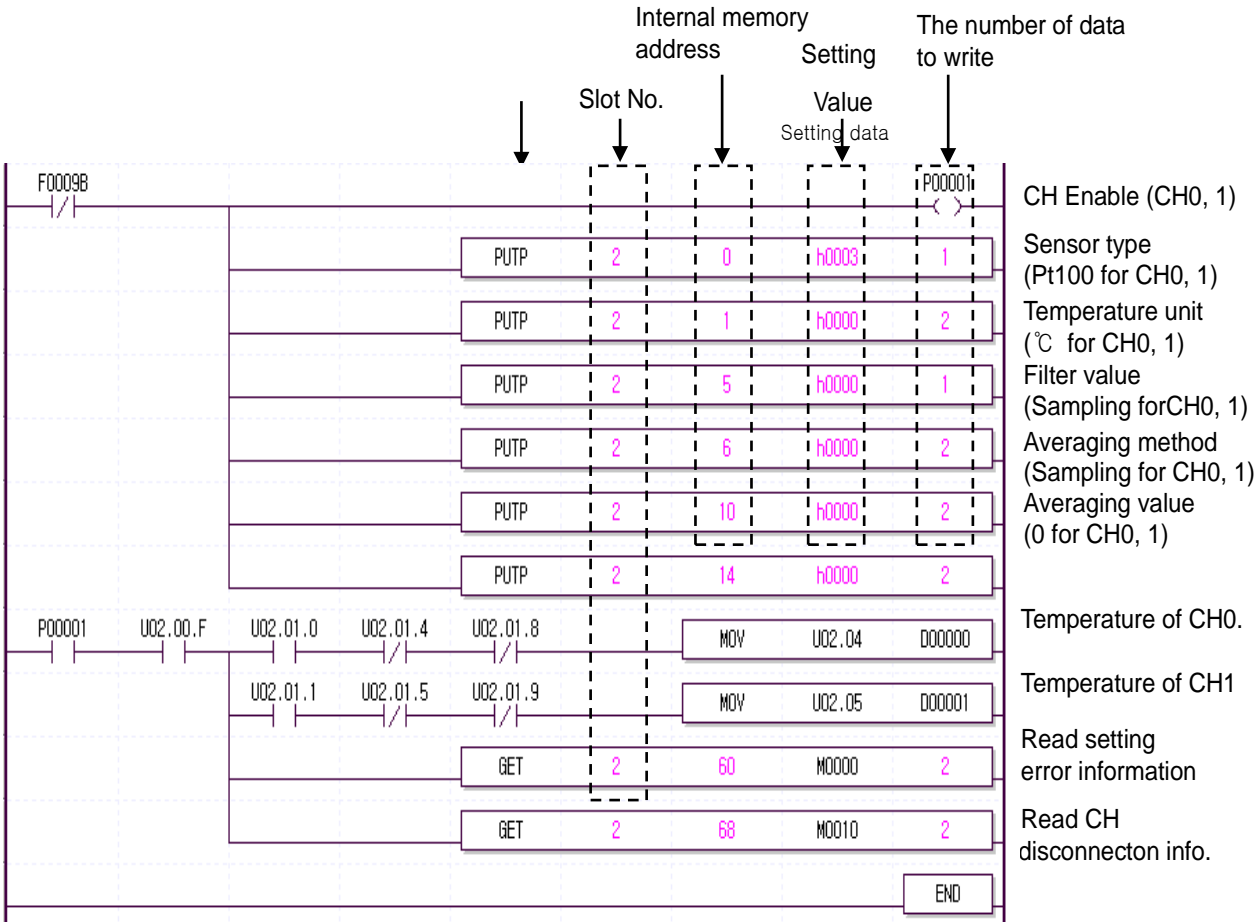

6.1.3 Application Program

- (1) Monitoring program of °C temperature-converted and scaled value
 ('Assign fixed points to I/O slot (64)' option is used)

(a) System Configuration

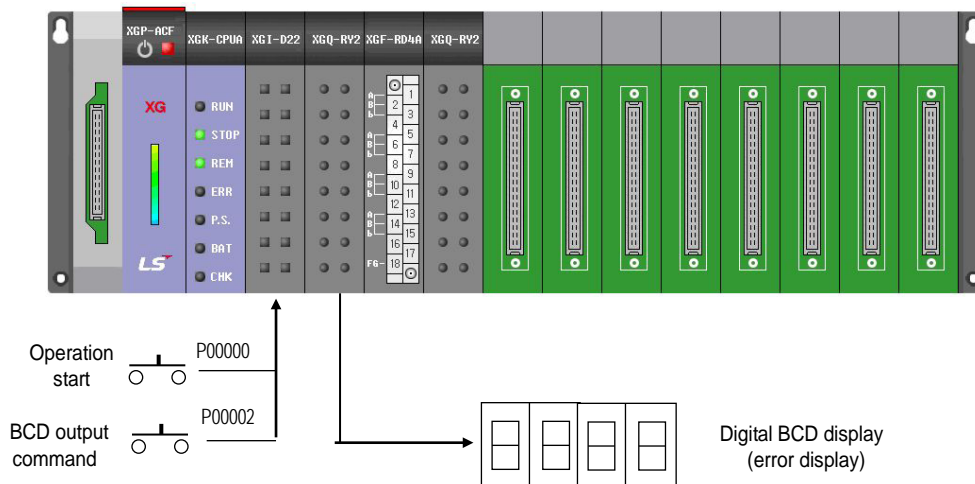

(b) Details of Initial Setting

No.	Item	Details of initial setting	Internal memory address	Value to write on internal memory
1	Used CH	CH0, CH2	0	'h005' or '5'
2	Sensor type	PT100(0)	1~4	'h0000' or '0'
3	Temp. display unit	°C (0)	5	'h0000' or '0'
4	Filter value	0	6~9	'h00C8' or '200'
5	Scaling type	0	18	'h0000' or '0'
6	Scaling range Max/Min	Max: 32767 Min: -32768	19~26	Max: h2710' or '10000' Min: h0000' or '0'

(c) Program description

- Temperature-converted value of CH0 and CH2 is output to D0 and D1 and scaled value to D10 and D11 by the operation start bit (P00000). At this time, scaled value is the temperature-converted value of -200 ~ 850°C converted to 0~10000.

Calculation formula is as below;

• Scaled calculation: $Y = \frac{10000}{10500} (X + 2000)$ Y : Scaling value , X : Temperature value

(However, the temperature value will be calculated and output in a format 10 times of the actual temperature value)

- It is the case that the filter value of CH0 and CH2 is set to “200” respectively so to change the temperature value by stages against sudden change of the temperature.

- 3) It outputs information of setting error and disconnection to M0 and M10 and outputs information of setting error details to P0012 in BCD with bit P00002 "ON".

(d) Program

- 1) Program example through [I/O parameters] setting

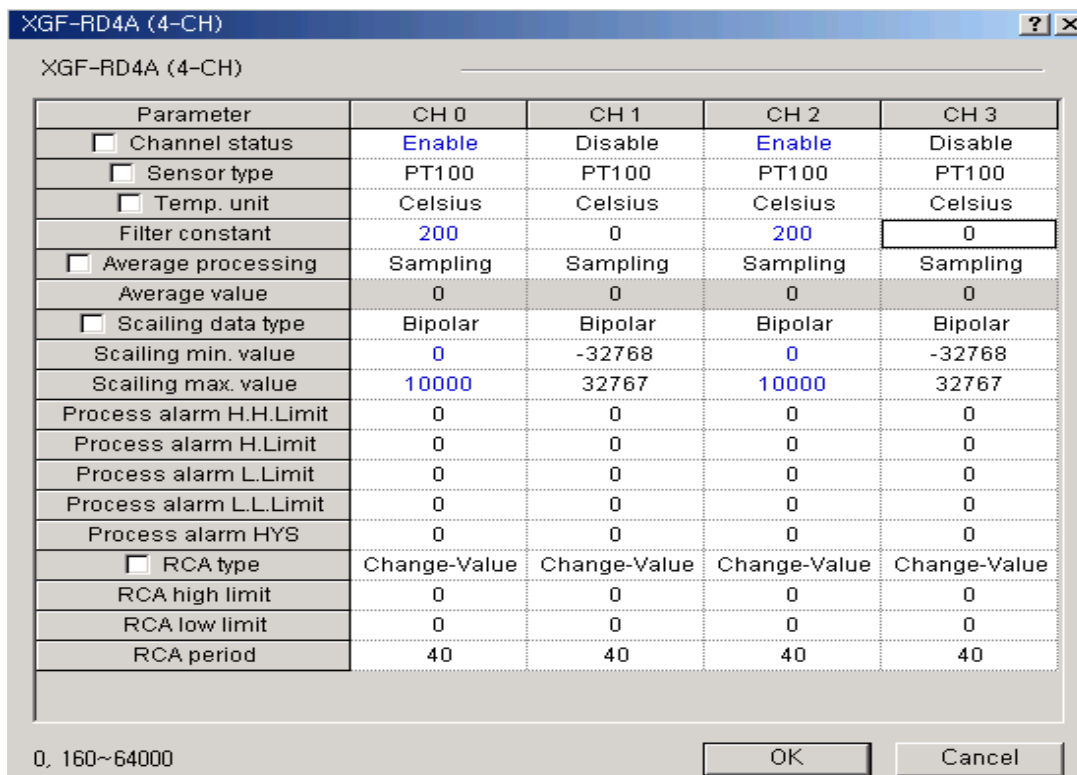
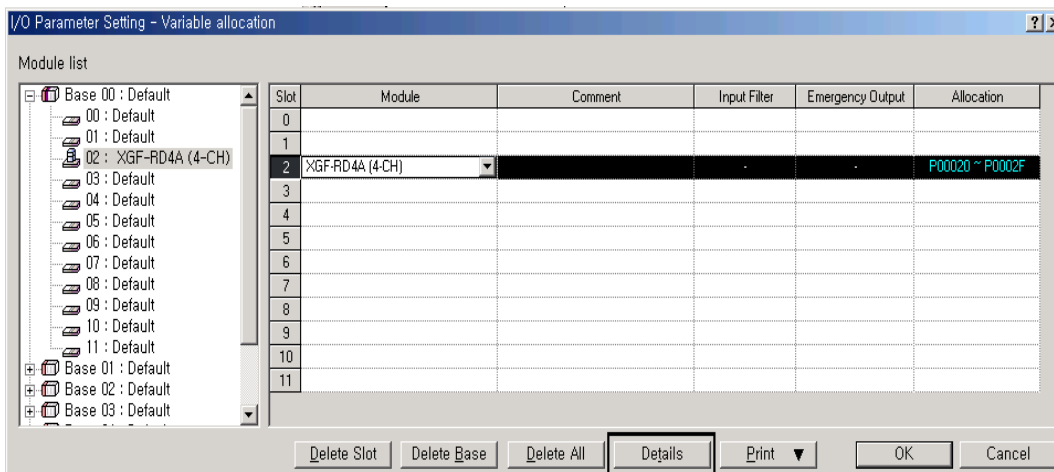

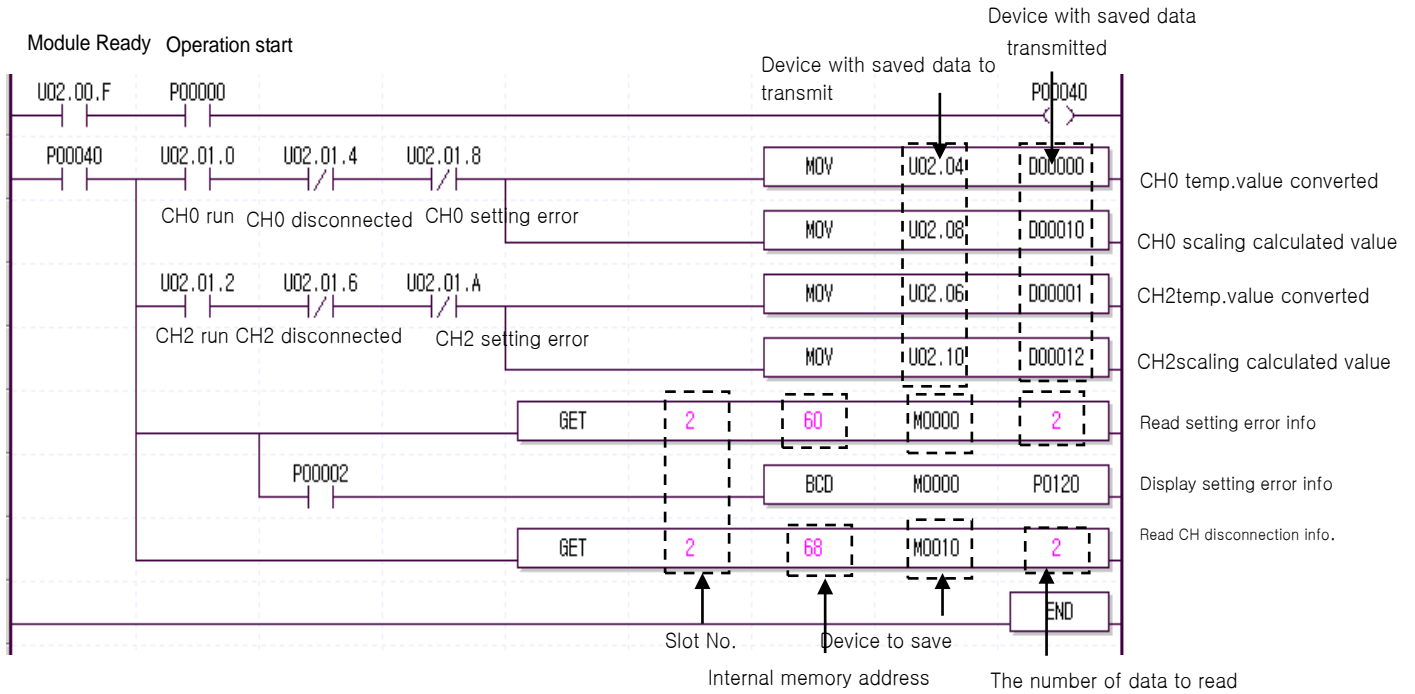

2) Program example with PUT/GET command used

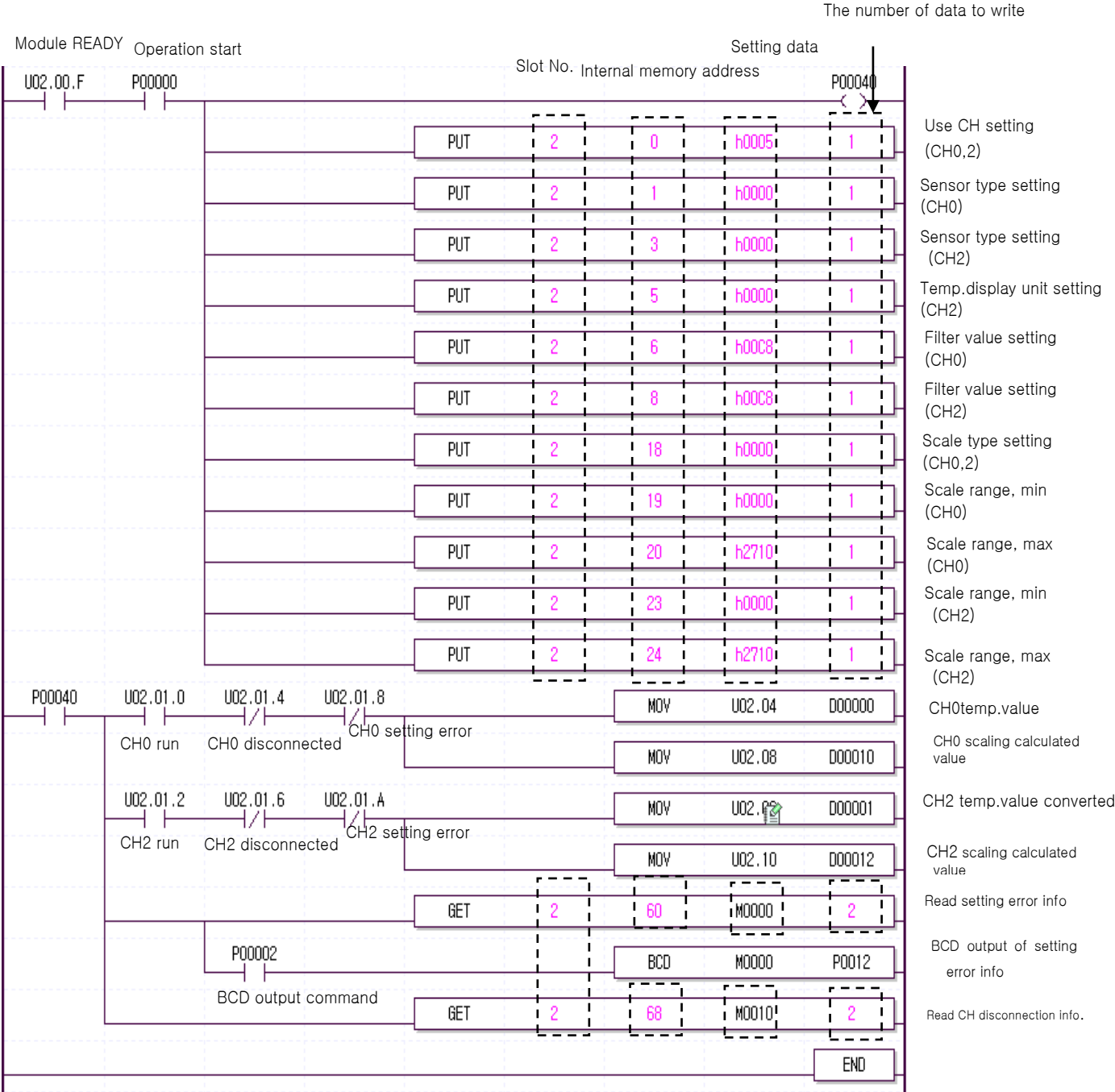

- (2) Program with °F temperature-converted value and highest/lowest process alarm
 (I/O slot fixed-points assigned: based on changeable type)

(a) System Configuration

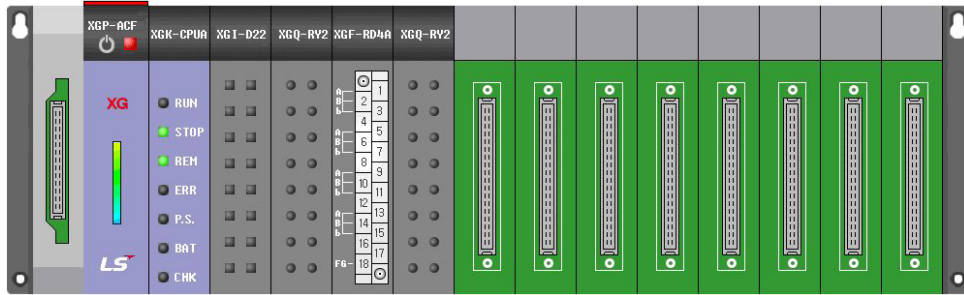

(b) Details of initial setting

- (1) Used CH: CH0
- (2) Sensor type: Pt100
- (3) Temperature unit: °F
- (4) High/Low process alarm setting: High = 2170, Low = 2070

(c) Description of program

- (1) If P00000 is On, the temperature-converted value of CH0 is output to D0.
- (2) This program is used to output the alarm to the output contact installed on the slot No. 3 by means of the highest/lowest process function if the highest/lowest process alarm range is exceeded.

(d) Program

- 1) Program example through [I/O parameters] setting

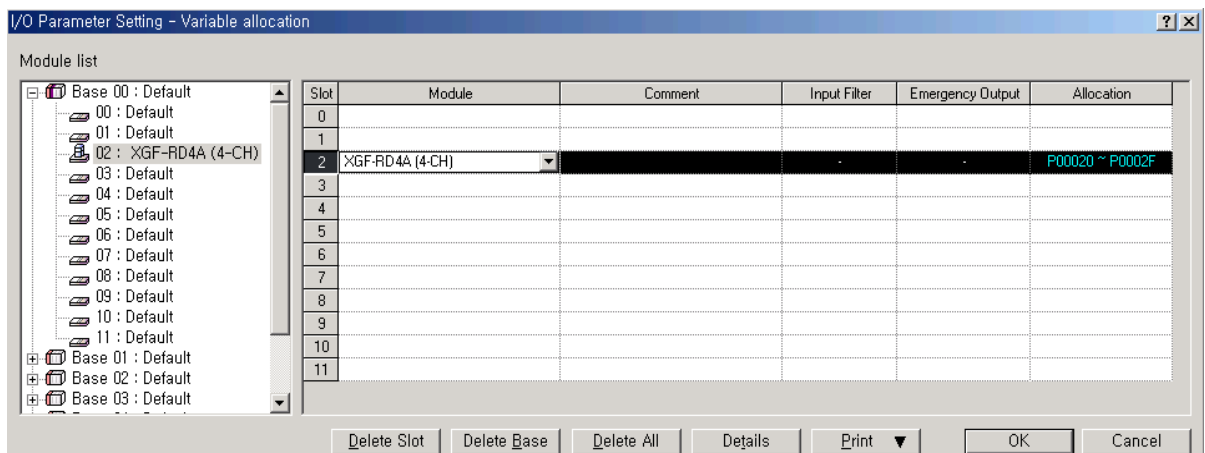

► I/O parameters setting screen

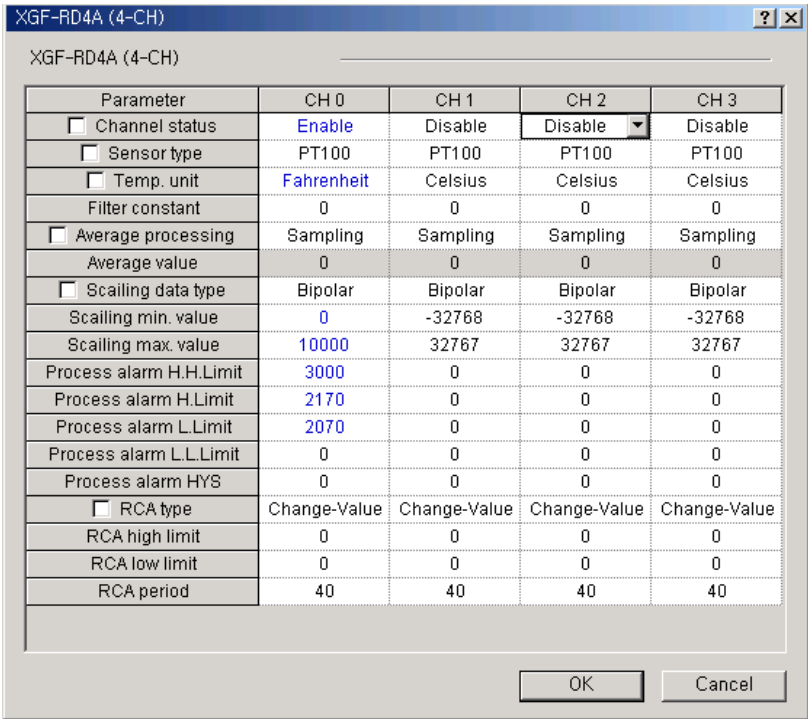

- Register the applicable module in the slot with the module installed on and specify the operation parameters to download to PLC.
- Select 'FLAG monitor' on the special module monitoring screen.

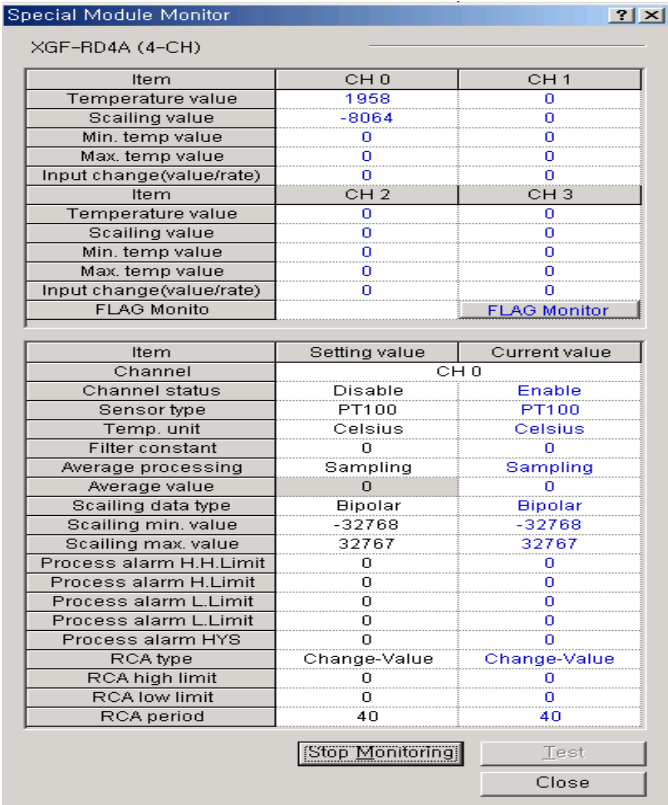

► Set the alarm operation of CH0 Enabled on the command screen of temperature input module.

XGF-RD4A (4-CH)		
Item	CH 0	CH 1
Channel status	Run	Stop
Sensor status	Normal	Normal
Process alarm(H.H.Limit)	ON	OFF
Process alarm(H.Limit)	ON	OFF
Process alarm(L.Limit)	OFF	OFF
Process alarm(L.L.Limit)	OFF	OFF
RCA high limit	ON	OFF
RCA low limit	ON	OFF
Item	CH 2	CH 3
Channel status	Stop	Stop
Sensor status	Normal	Normal
Process alarm(H.H.Limit)	OFF	OFF
Process alarm(H.Limit)	OFF	OFF
Process alarm(L.Limit)	OFF	OFF
Process alarm(L.L.Limit)	OFF	OFF
RCA high limit	OFF	OFF
RCA low limit	OFF	OFF
Command	CH 0	CH 1
Max/Min active	DISABLE	DISABLE
Alarm active	ENABLE	DISABLE
Command	CH 2	CH 3
Max/Min active	DISABLE	DISABLE
Alarm active	DISABLE	DISABLE

Cancel

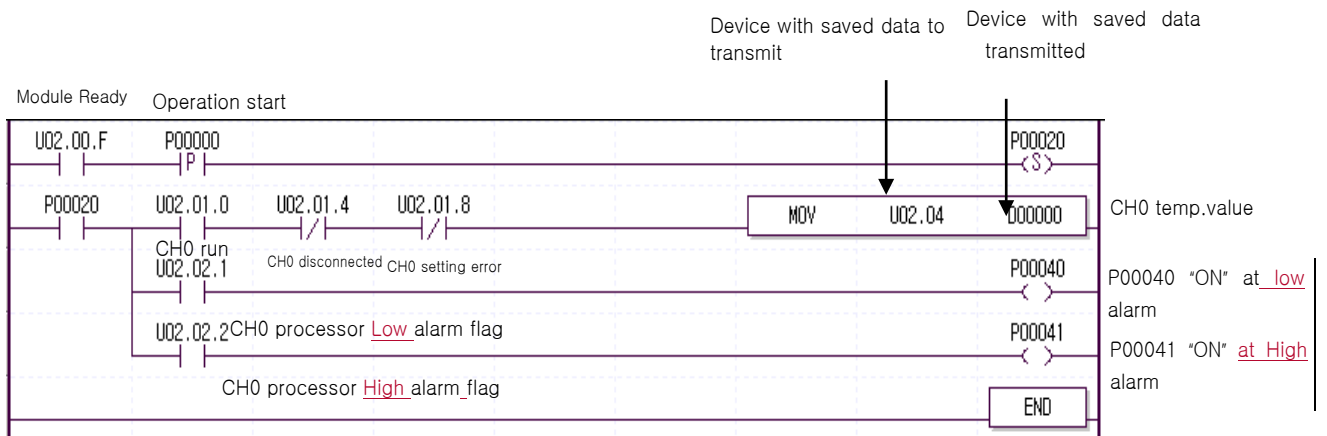

2) Program example with PUT/GET command used

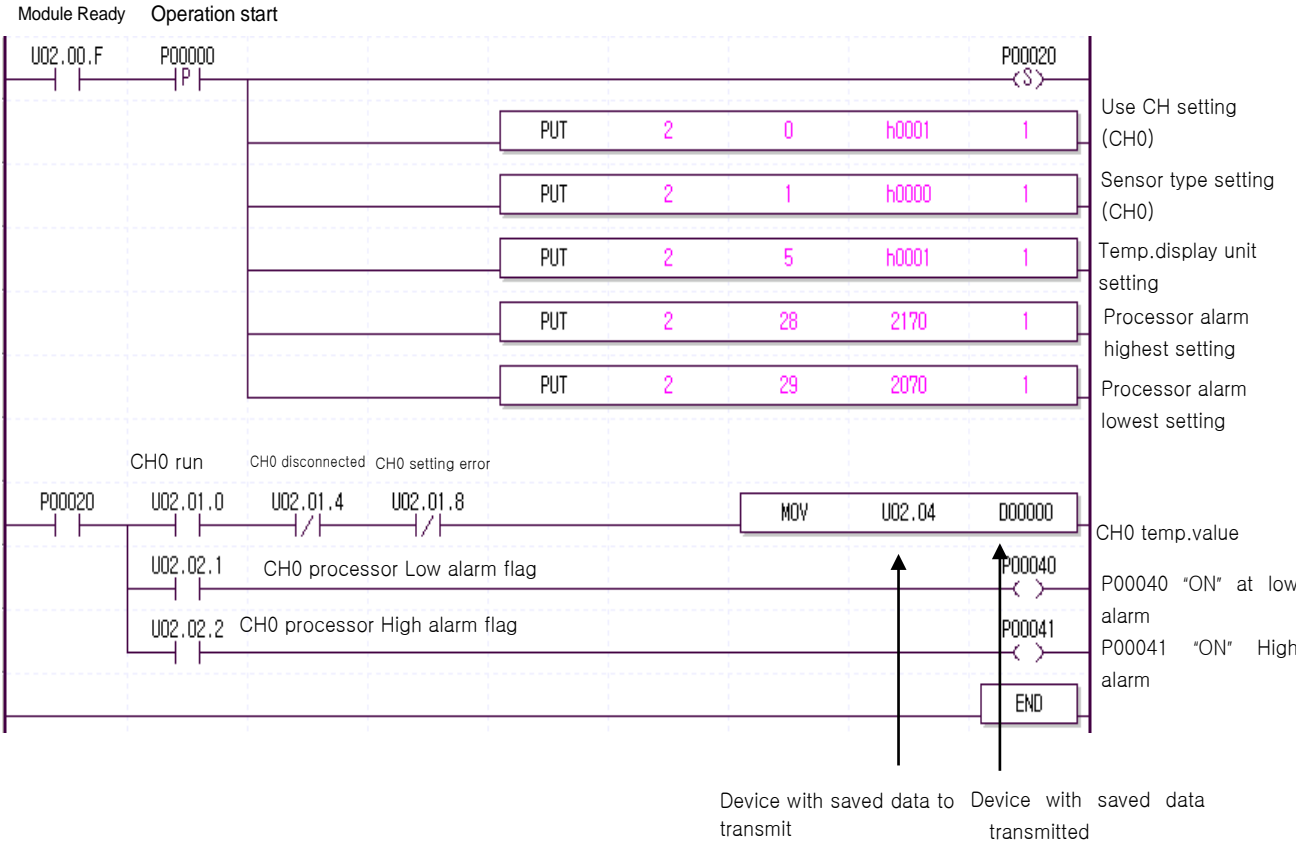

6.2 XGF-RD8A

6.2.1 Read/Write of Operation Parameters Setting Area

(1) Read of operation parameters setting area (GETE, GETEP command)

Instruction	Area available														step	Flag		
	PMK	F	L	T	C	S	Z	D.x	R.x	const	U	N	D	R		Error (F110)	Zero (F111)	Carry (F112)
GET(P)	sl	-	-	-	-	-	-	-	-	-	0	-	-	-	5	0	-	-
	S	-	-	-	-	-	-	-	-	-	0	-	-	-				
	M	0	-	0							0	0	0	0				
	D	0	-	0	-	-	-	-	-	-	-	0	0	0				
	N	0	-	0	-	-	-	-	-	-	0	0	0	0				

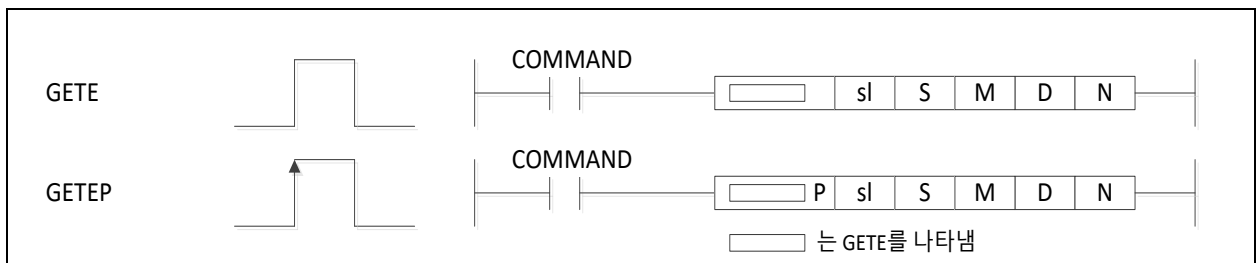

[Setting area]

Operand	Description	Operand type	Available size	Data size
sl	Slot No. where special module is installed on	Value	Constant	WORD
S	Start address of internal memory of special module to read	Value	Constant	WORD
M	Select word size address out of internal memory of special module to read	Value or Address	Constant 2byte	WORD
D	Start memory address of CPU module where the read data will be saved in	Address	2byte	WORD
N	Number of words data to read	Value or Address	Constant 2byte	WORD

[Flag Set]

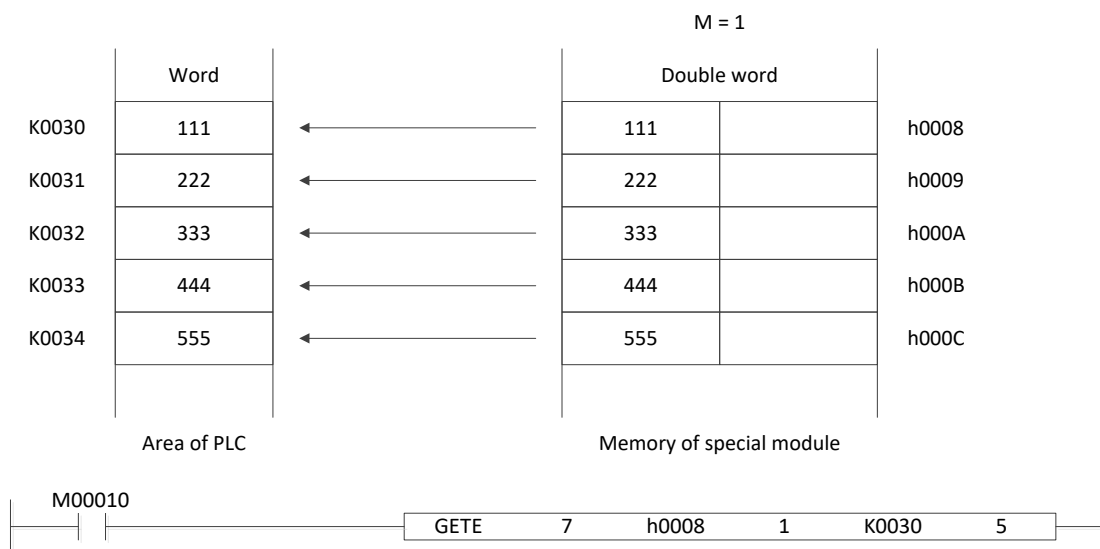

Flag	Description	Device no.
Error	<ol style="list-style-type: none"> RTD module is not installed or other module is installed in designated slot. Set operand S or more 1024(h400). Set operand M except 0 or1 Set operand N out of 1 to 64 The result of adding number of words data to read (n3) to the remainder of dividing address of internal memory by 64 is larger than 64. For example, in case of setting 63 address of internal memory and larger than 2 words data to read, occur to error. This is because memory sizes of the command limit within 64 words at a time. Device about three times the number set in the operand N from Device that is set in the operand D, when it is out of the maximum setting range of the device. 	F110

Ex. If RTD module is installed on Base No.0 and Slot No.7, and read the data of upper word area of the 8th memory in RTD module to device K0030 to K0034 of CPU module while M00000 bit turned on.

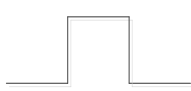
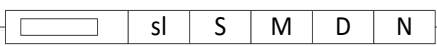

(2) Write of operation parameters setting area (PUTE, PUTEP command)

Instruction	Area available														step	Flag		
	PMK	F	L	T	C	S	Z	D.x	R.x	const	U	N	D	R		Error (F110)	Zero (F111)	Carry (F112)
GET(P)	sl	-	-	-	-	-	-	-	-	-	0	-	-	-	5	0	-	-
	S	-	-	-	-	-	-	-	-	-	0	-	-	-				
	M	0	-	0							0	0	0	0				
	D	0	-	0	-	-	-	-	-	-	-	0	0	0				
	N	0	-	0	-	-	-	-	-	-	0	0	0	0				

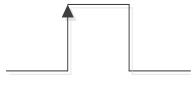
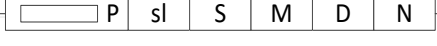
PUTE		COMMAND						
								
PUTEP		COMMAND						

[Setting area]

Operand	Description	Operand type	Available size	Data size
sl	Slot No. where special module is installed on	Value	Constant	WORD
S	Start address of internal memory of special module to read	Value	Constant	WORD
M	Select word size address out of internal memory of special module to read	Value or Address	Constant 2byte	WORD
D	Start memory address of CPU module where the read data will be saved in	Address	2byte	WORD
N	Number of words data to read	Value or Address	Constant 2byte	WORD

[Flag Set]

Flag	Description	Device no.
Error	1. RTD module is not installed or other module is installed in designated slot. 2. Set operand S or more 1024(h400). 3. Set operand M except 0 or 1 4. Set operand N out of 1 to 64 5. The result of adding number of words data to write (n3) to the remainder of dividing address of internal memory by 64 is larger than 64. 6. Device about three times the number set in the operand N from Device that is set in the operand D, when it is out of the maximum setting range of the device.	F110

Ex. If RTD module is installed on Base No.0 and Slot No.1, and read the data of lower word area of the 0th memory in RTD module to device D00100 to D00102 of CPU module while M00000 bit turned on.

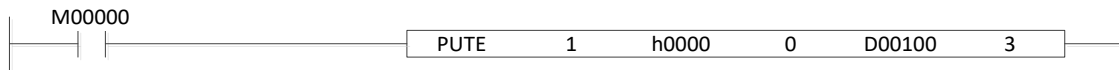
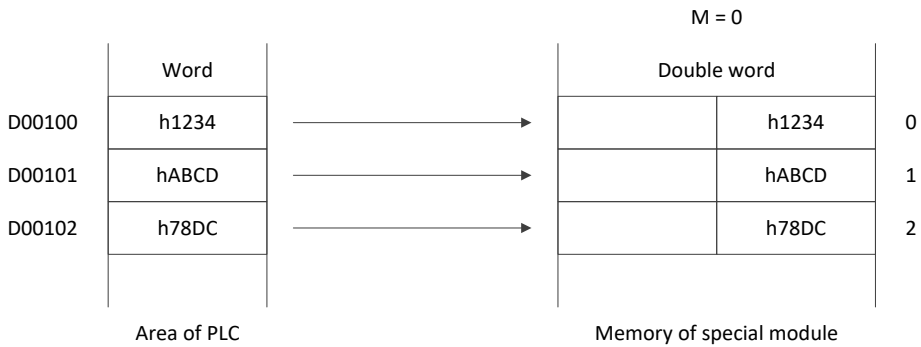

6.2.2 Basic Program

- How to specify operation condition details of RTD input module's internal memory is described.
- RTD module is assumed to be installed on Slot 2.
- Assigned I/O points of RTD module is 16 points when 'Assign fixed points to I/O slot (64)' option in the basic parameter is not used.
- The setting values specified in the [I/O Parameter] will be saved on the RTD module one time when the parameter is downloaded and the module is initialized.

(1) Program example through [I/O parameters] setting : XGF-RD8A

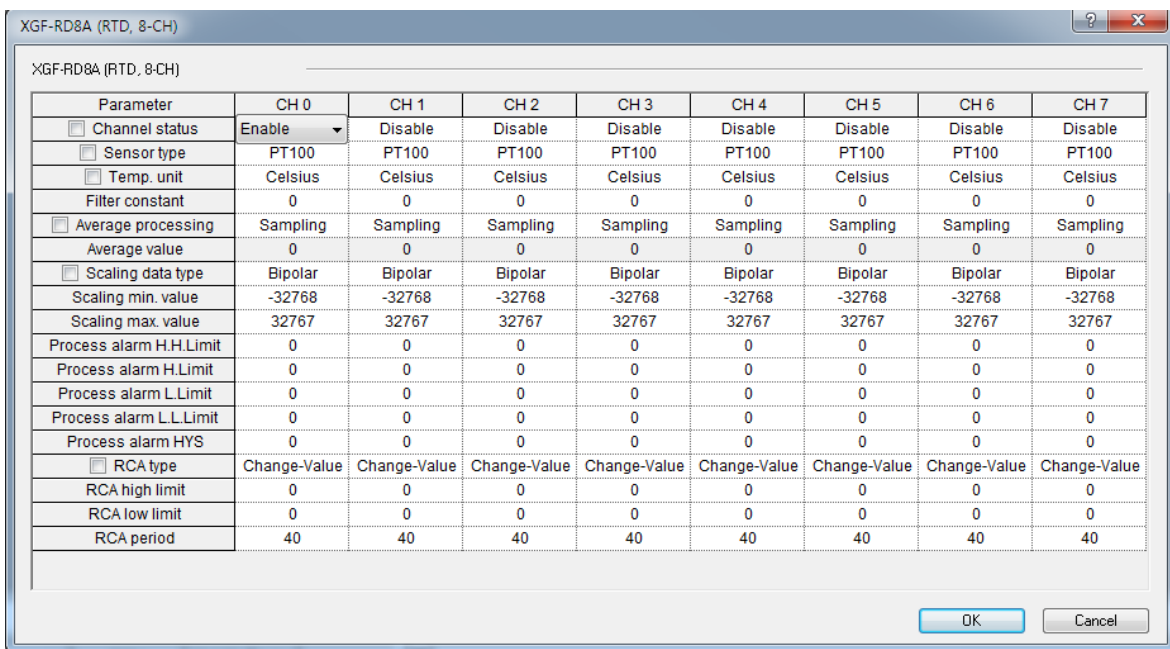
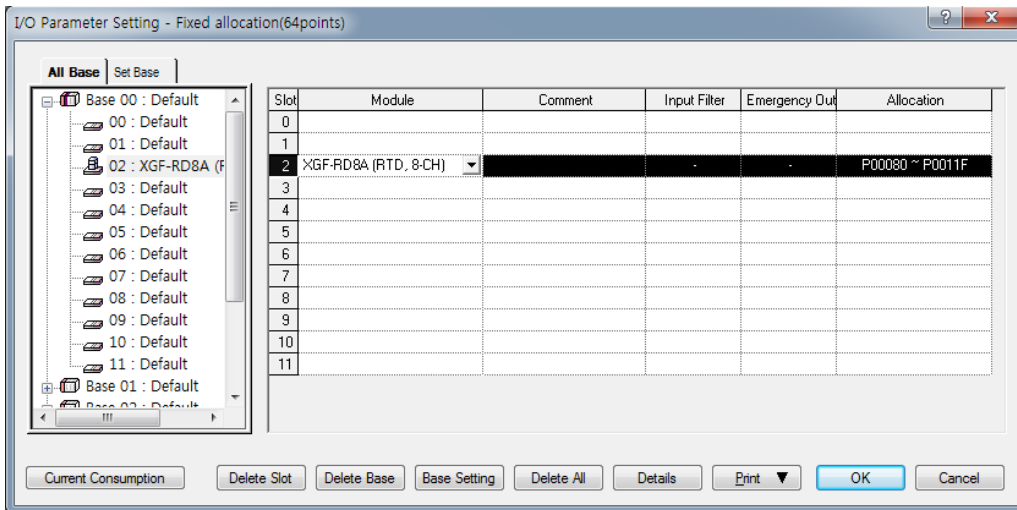

► Register the applicable module in the slot where the module is installed on ,and specify the operation parameters to download to PLC.

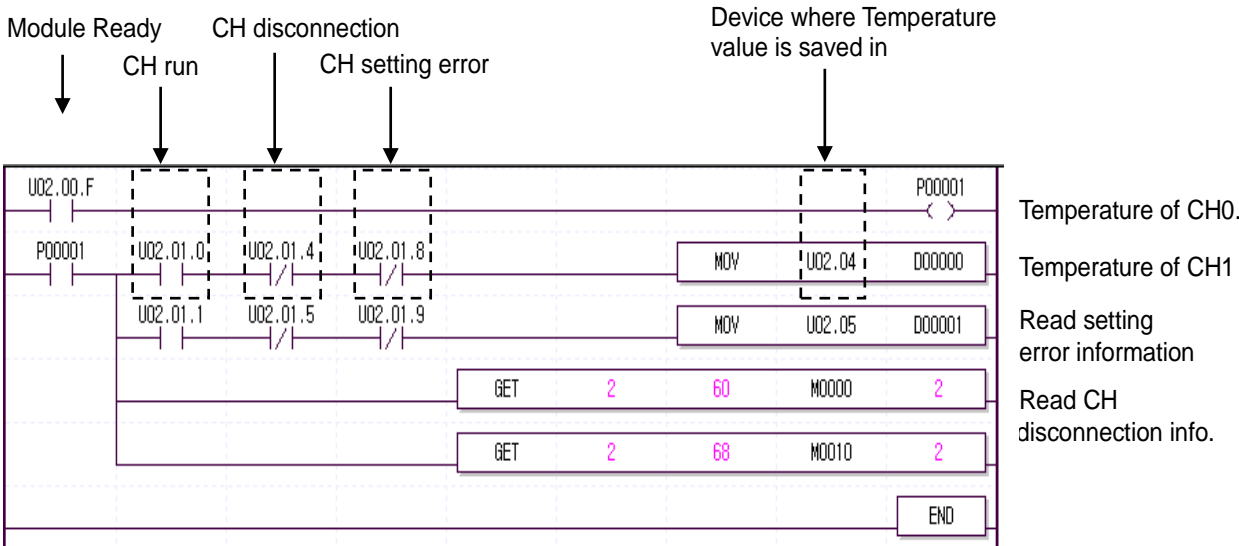

(2) Program example using PUT/GET command

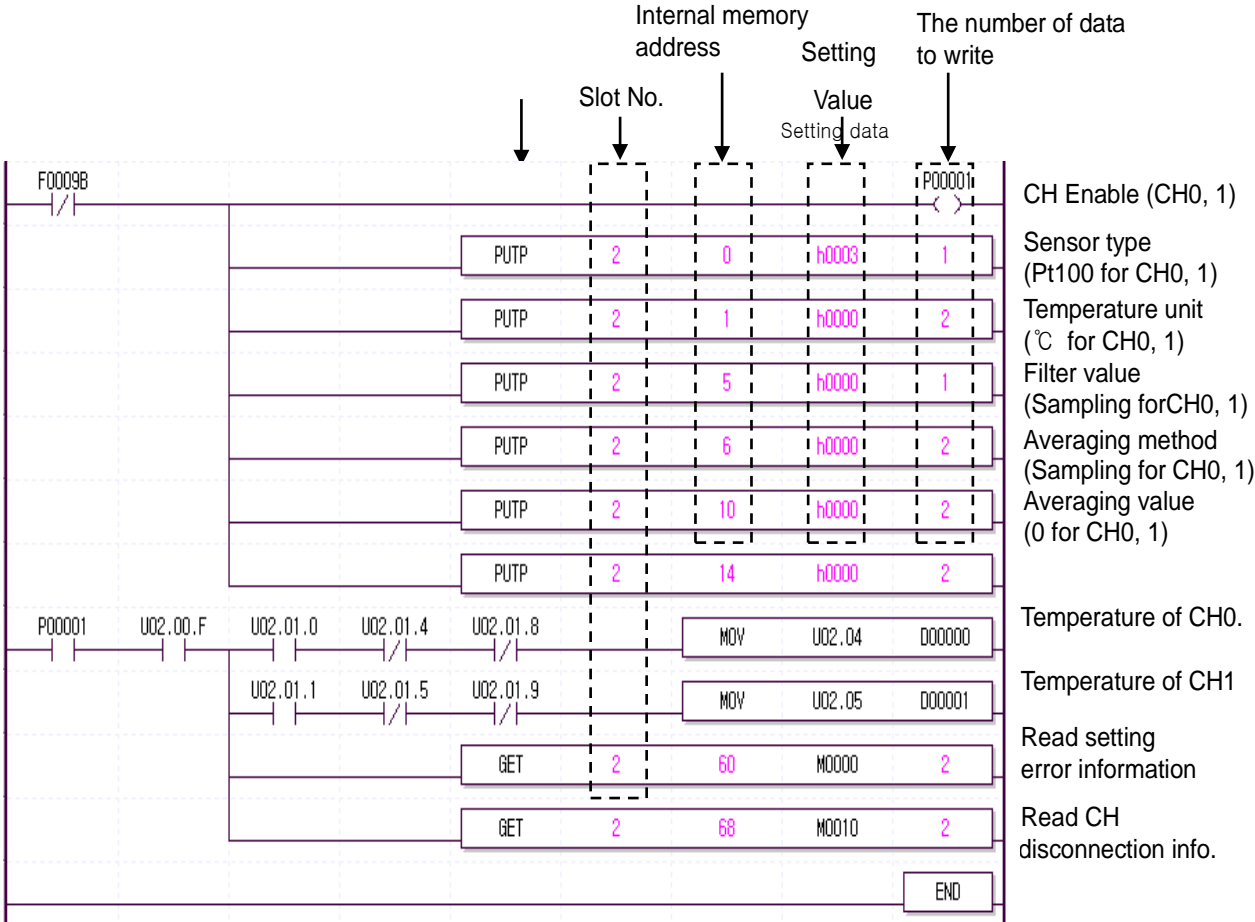

6.2.3 Application Program

(1) Monitoring program of °C temperature-converted and scaled value ('Assign fixed points to I/O slot (64)' option is used)

(a) System Configuration

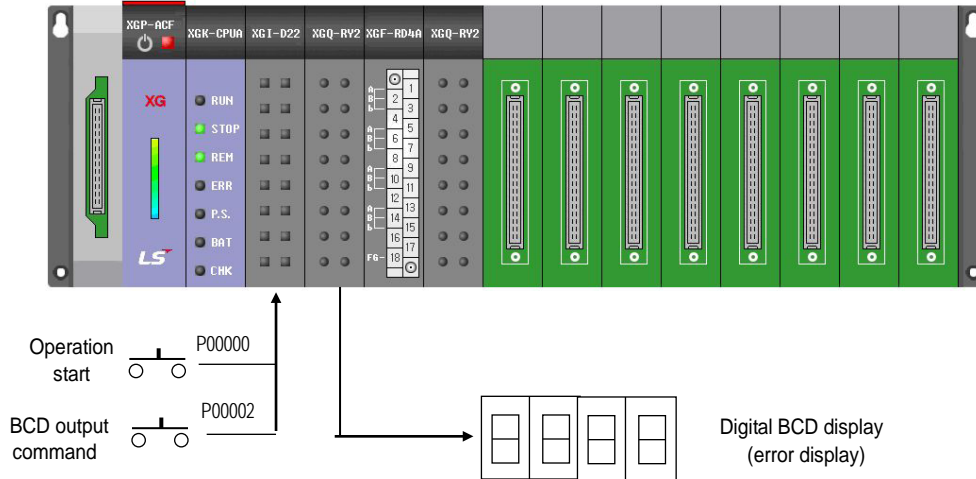

(b) Details of Initial Setting

No.	Item	Details of initial setting	Internal memory address	Value to write on internal memory
1	Used CH	CH0, CH2	0	'h005' or '5'
2	Sensor type	PT100(0)	1~4	'h0000' or '0'
3	Temp. display unit	°C (0)	5	'h0000' or '0'
4	Filter value	0	6~9	'h00C8' or '200'
5	Scaling type	0	18	'h0000' or '0'
6	Scaling range Max/Min	Max: 32767 Min:-32768	19~26	Max:h2710' or '10000' Min: h0000' or '0'

(c) Program description

1) Temperature-converted value of CH0 and CH2 is output to D0 and D1 and scaled value to D10 and D11 by the operation start bit (P00000). At this time, scaled value is the temperature-converted value of -200 ~ 850 °C converted to 0~10000.

Calculation formula is as below;

• Scaled calculation: $Y = \frac{10000}{10500}(X + 2000)$ Y : Scaling value , X : Temperature value

(However, the temperature value will be calculated and output in a format 10 times of the actual temperature value)

- 2) It is the case that the filter value of CH0 and CH2 is set to "200" respectively so to change the temperature value by stages against sudden change of the temperature.
- 3) It outputs information of setting error and disconnection to M0 and M10 and outputs information of setting error details to P0012 in BCD with bit P00002 "On".

(d) Program

1) Program example through [I/O parameters] setting

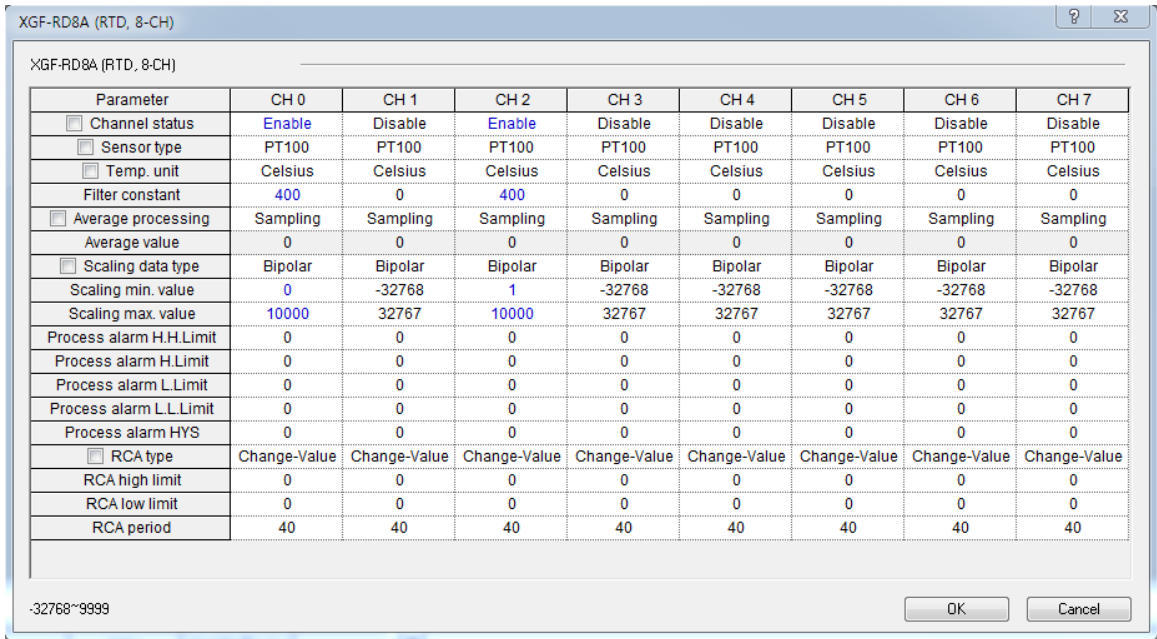
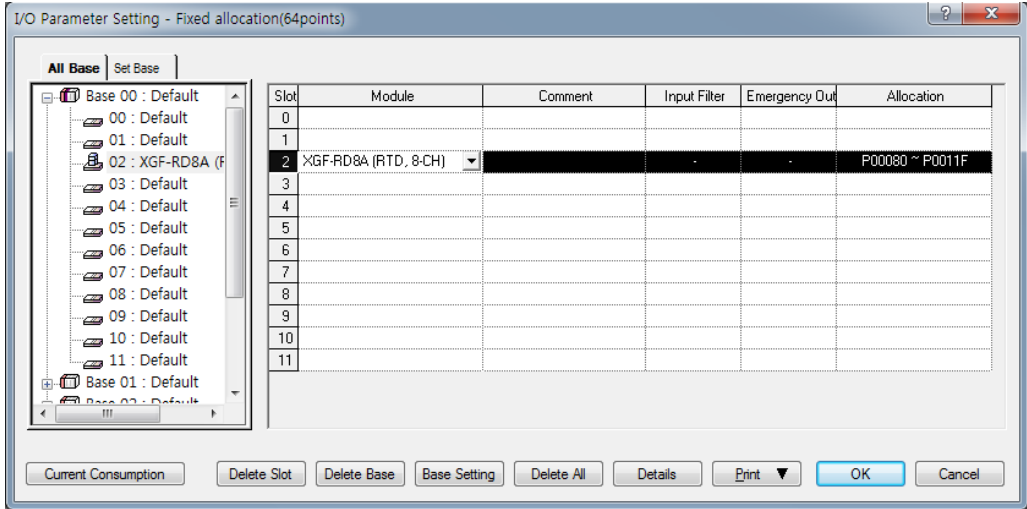

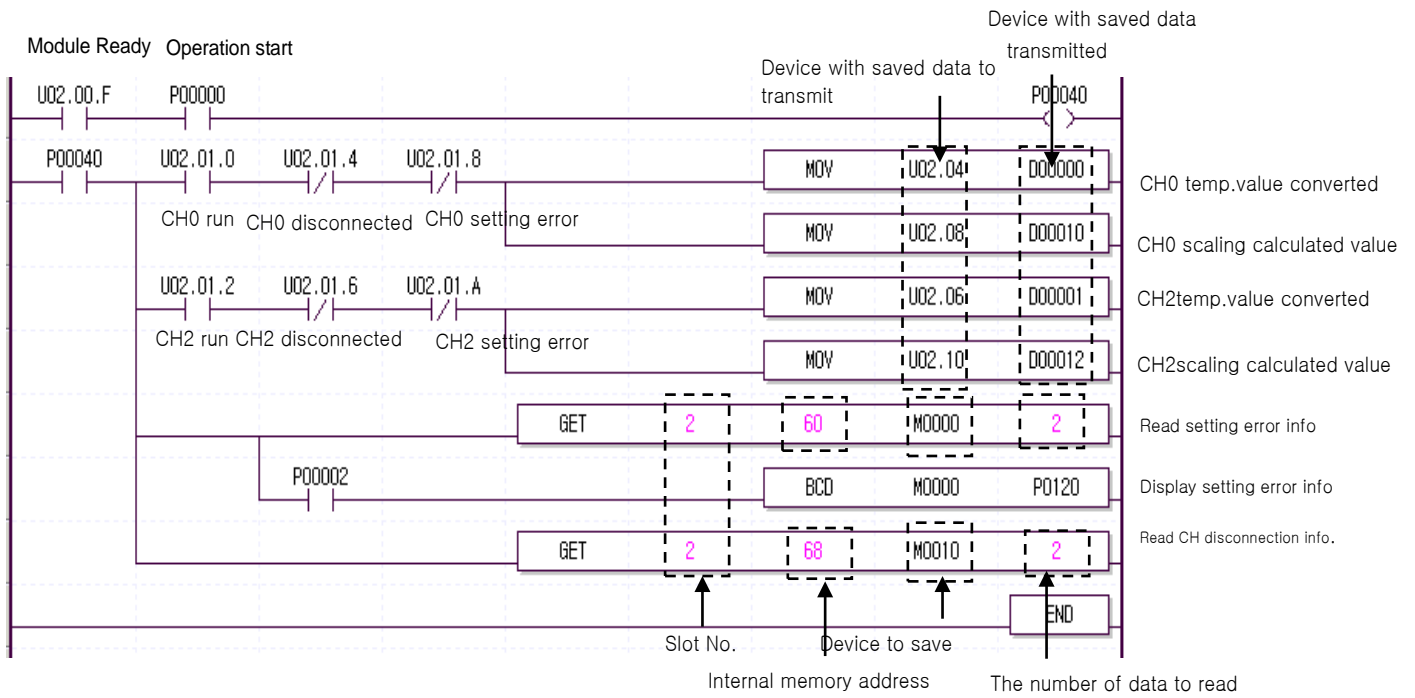

2) Program example with PUT/GET command used

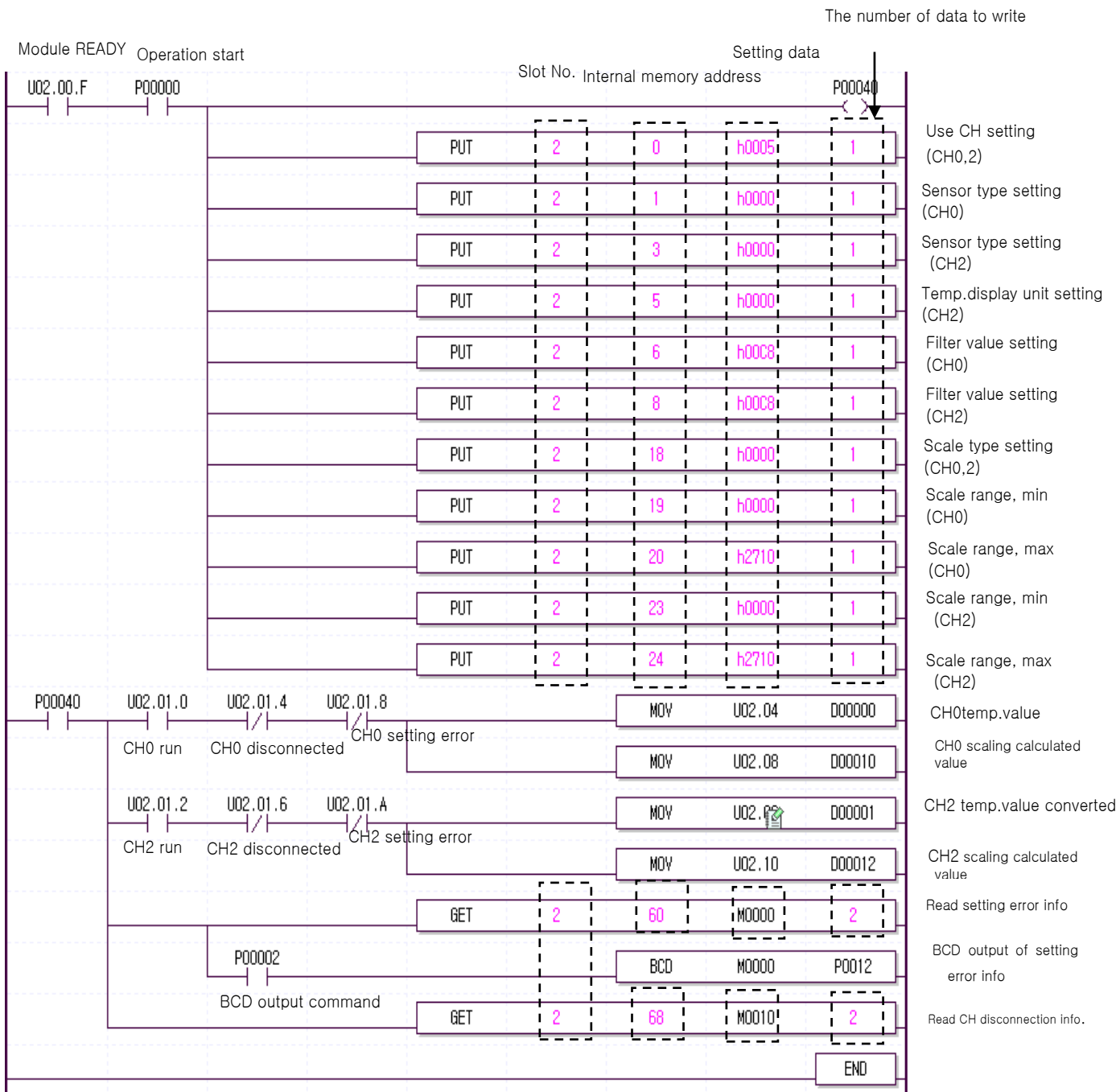

(2) Program with °F temperature-converted value and highest/lowest process alarm
 (I/O slot fixed-points assigned: based on changeable type)

(a) System Configuration

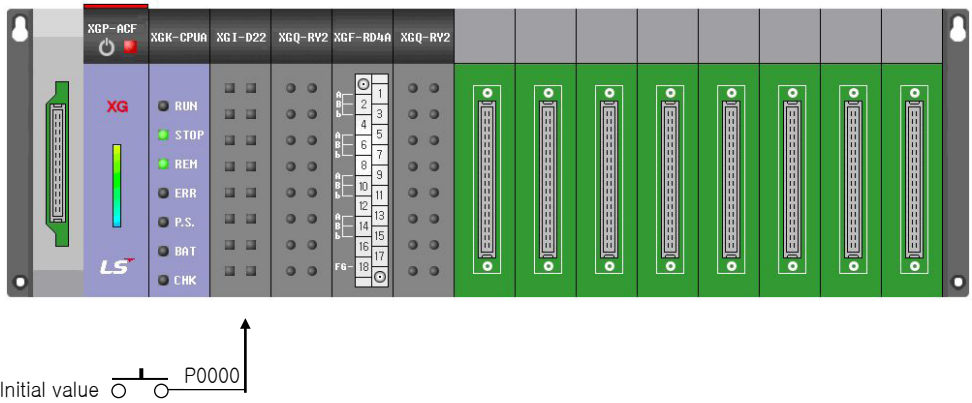

(b) Details of initial setting

- a) Used CH: CH0
- b) Sensor type: Pt100
- c) Temperature unit: °F
- d) High/Low process alarm setting: High = 2170, Low = 2070

(c) Description of program

- 1) If P00000 is On, the temperature-converted value of CH0 is output to D0.
- 2) This program is used to output the alarm to the output contact installed on the slot No. 3 by means of the highest/lowest process function if the highest/lowest process alarm range is exceeded.

(d) Program

1) Program example through [I/O parameters] setting

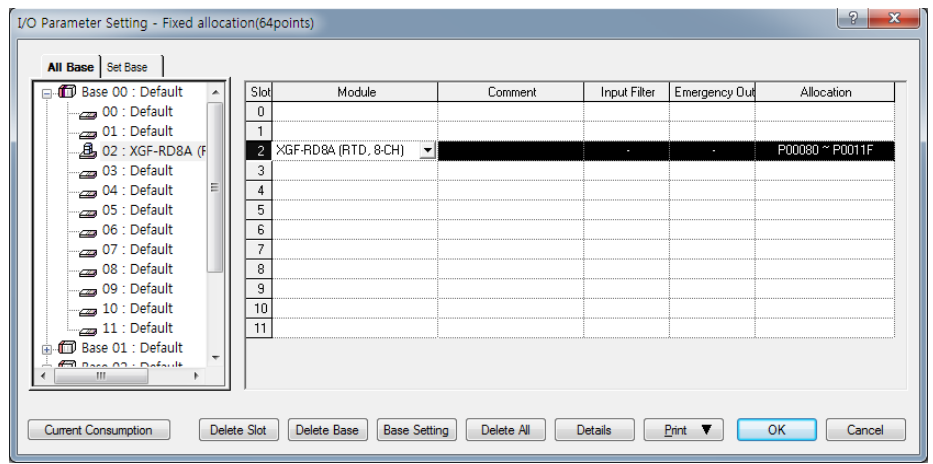

► I/O parameters setting screen

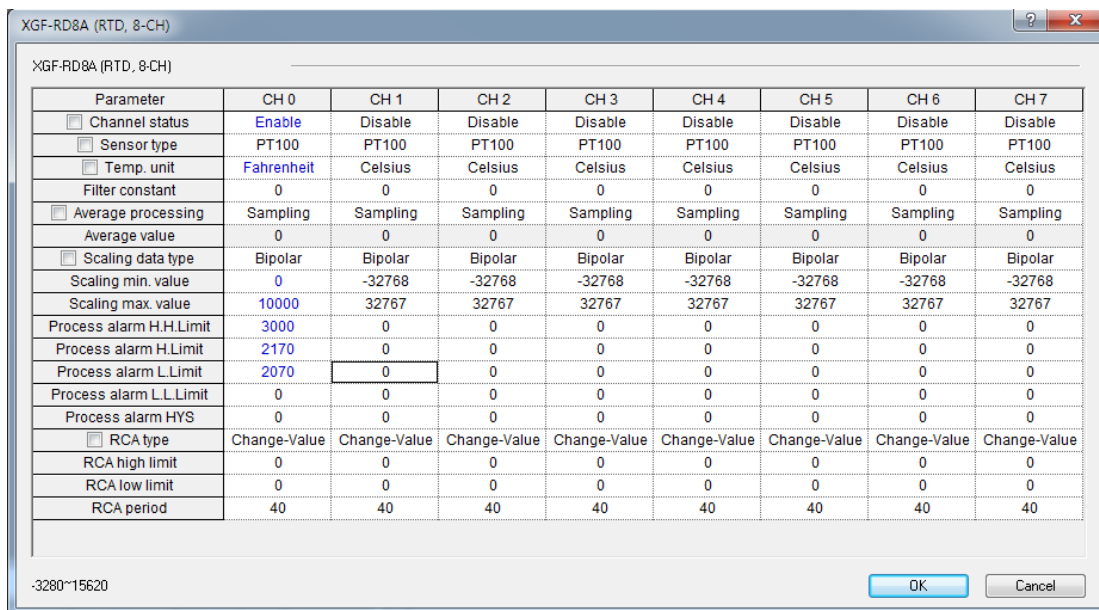

► Register the applicable module in the slot with the module installed on and specify the operation parameters to download to PLC.

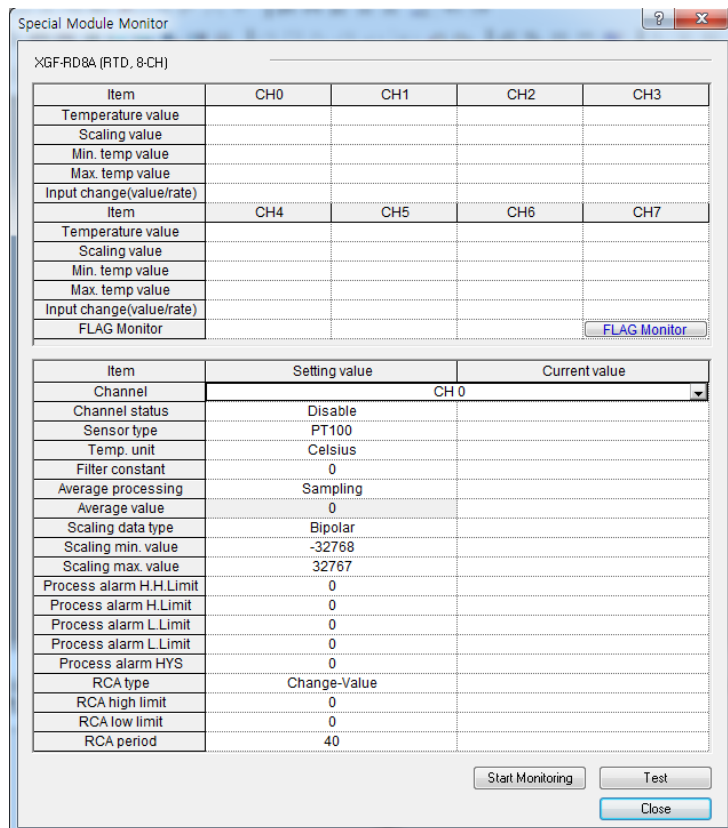

► Select 'FLAG monitor' on the special module monitoring screen.

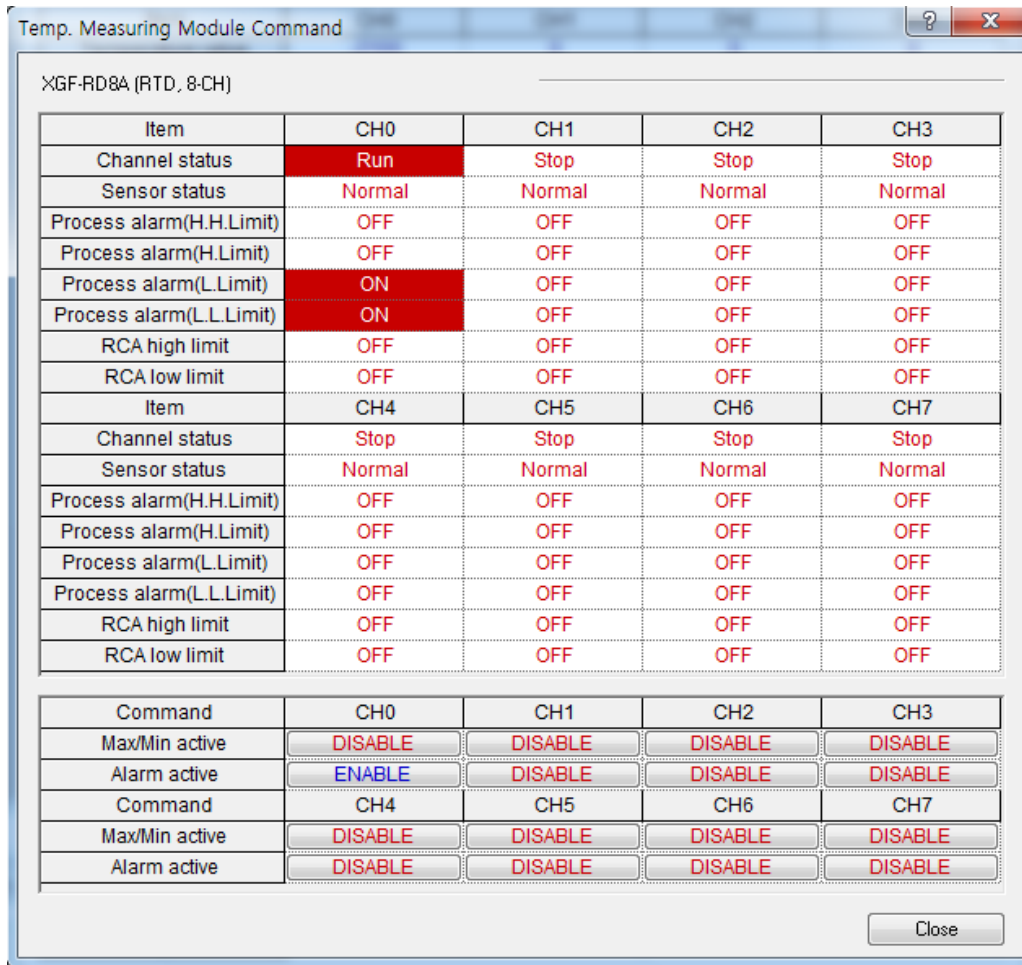

► Set the alarm operation of CH0 Enabled on the command screen of temperature input module.

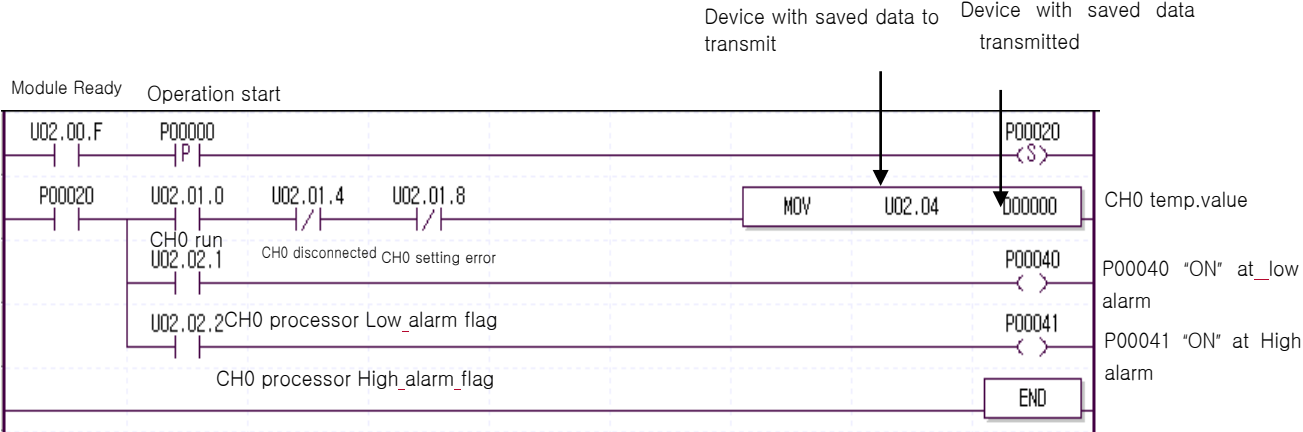

2) Program example with PUT/GET command used

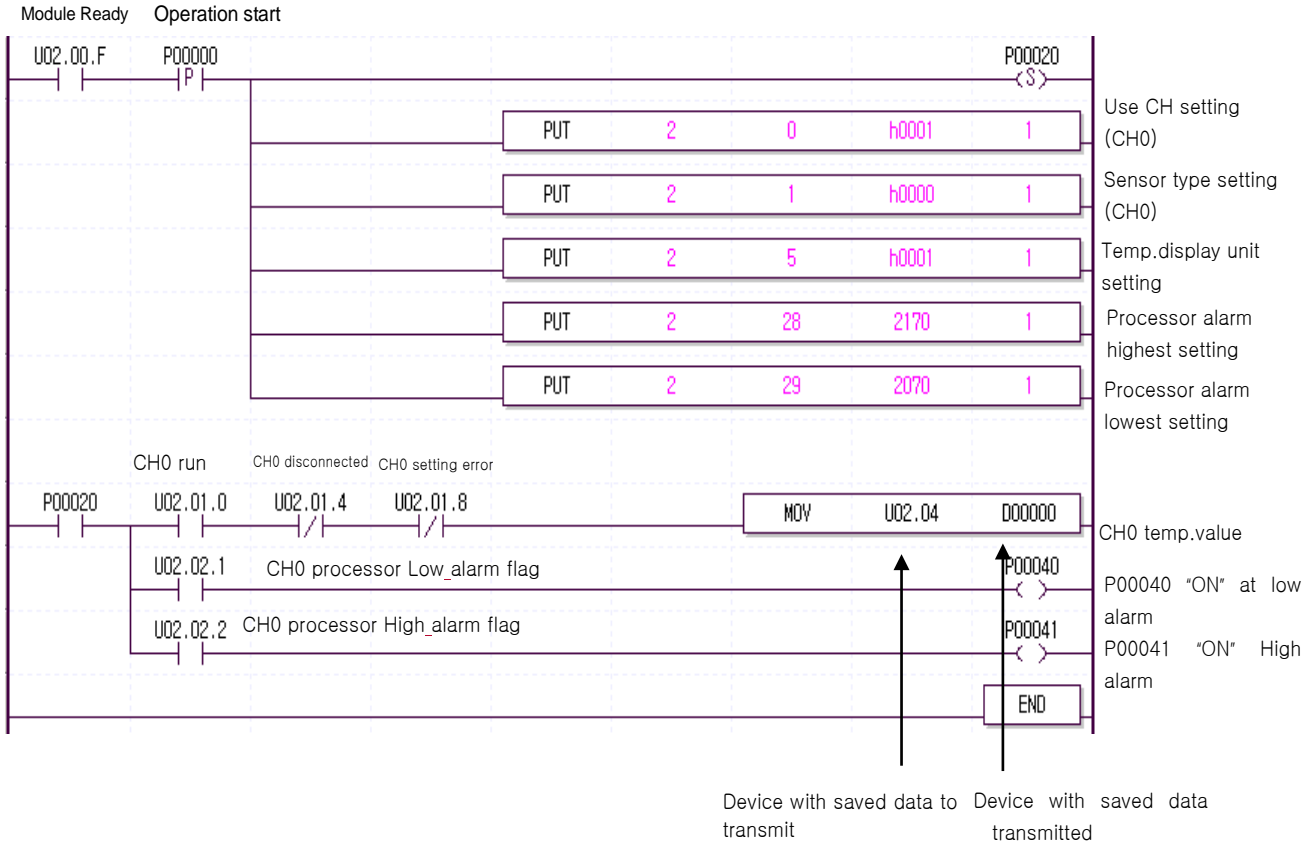

Chapter 7 Global Variable Configuration and Function (For XGI/XGR)

7.1 XGF-RD4A/XGF-RD4S

7.1.1 Global variable (Data area)

(1) Conversion data I/O area

Temperature conversion data I/O area is indicated at table 7.1

[Table 7. 1] conversion data I/O area

Global variable	Memory assignment	Contents	Read/write
_xxyy_CH0_ADJERR	%UXxx.yy.0	CH 0 offset/gain adjustment error	Read
_xxyy_CH1_ADJERR	%UXxx.yy.1	CH 1 offset/gain adjustment error	
_xxyy_CH2_ADJERR	%UXxx.yy.2	CH 2 offset/gain adjustment error	
_xxyy_CH3_ADJERR	%UXxx.yy.3	CH 3 offset/gain adjustment error	
_xxyy_WDT_ERR	%UXxx.yy.14	Module H/W error	
_xxyy_RDY	%UXxx.yy.15	Module Ready	
_xxyy_CH0_ACT	%UXxx.yy.16	CH 0 Operating	Read
_xxyy_CH1_ACT	%UXxx.yy.17	CH 1 Operating	Read
_xxyy_CH2_ACT	%UXxx.yy.18	CH 2 Operating	Read
_xxyy_CH3_ACT	%UXxx.yy.19	CH 3 Operating	Read
_xxyy_CH0_BOUT	%UXxx.yy.20	CH 0 disconnection	Read
_xxyy_CH1_BOUT	%UXxx.yy.21	CH 1 disconnection	Read
_xxyy_CH2_BOUT	%UXxx.yy.22	CH 2 disconnection	Read
_xxyy_CH3_BOUT	%UXxx.yy.23	CH 3 disconnection	Read
_xxyy_CH0_SETERR	%UXxx.yy.24	CH 0 setting error	Read
_xxyy_CH1_SETERR	%UXxx.yy.25	CH 1 setting error	Read
_xxyy_CH2_SETERR	%UXxx.yy.26	CH 2 setting error	Read
_xxyy_CH3_SETERR	%UXxx.yy.27	CH 3 setting error	Read
_xxyy_CH0_PALL	%UXxx.yy.32	CH 0 process alarm low-low limit flag	Read/Write
_xxyy_CH0_PAL	%UXxx.yy.33	CH 0 process alarm low limit flag	
_xxyy_CH0_PAH	%UXxx.yy.34	CH 0 process alarm high limit flag	
_xxyy_CH0_PAHH	%UWxx.yy.35	CH 0 process alarm high-high limit flag	
_xxyy_CH1_PALL	%UWxx.yy.36	CH 1 process alarm low-low limit flag	
_xxyy_CH1_PAL	%UWxx.yy.37	CH 1 process alarm low limit flag	
_xxyy_CH1_PAH	%UWxx.yy.38	CH 1 process alarm high limit flag	
_xxyy_CH1_PAHH	%UWxx.yy.39	CH 1 process alarm high-high limit flag	
_xxyy_CH2_PALL	%UWxx.yy.40	CH 2 process alarm low-low limit flag	
_xxyy_CH2_PAL	%UWxx.yy.41	CH 2 process alarm low limit flag	
_xxyy_CH2_PAH	%UWxx.yy.42	CH 2 process alarm high limit flag	
_xxyy_CH2_PAHH	%UWxx.yy.43	CH 2 process alarm high-high limit flag	
_xxyy_CH3_PALL	%UWxx.yy.44	CH 3 process alarm low-low limit flag	
_xxyy_CH3_PAL	%UWxx.yy.45	CH 3 process alarm low limit flag	
_xxyy_CH31_PAH	%UWxx.yy.46	CH 3 process alarm high limit flag	
_xxyy_CH3_PAHH	%UWxx.yy.47	CH 3 process alarm high-high limit flag	

[Table 7. 1] conversion data I/O area

Global variable	Memory assignment	Contents	Read/write
_xxyy_CH0_RAL	%UXxx.yy.48	CH0 change rate alarm low limit flag	Read
_xxyy_CH0_RAH	%UXxx.yy.49	CH0 change rate alarm high limit flag	Read
_xxyy_CH1_RAL	%UXxx.yy.52	CH1 change rate alarm low limit flag	Read
_xxyy_CH1_RAH	%UXxx.yy.53	CH1 change rate alarm high limit flag	Read
_xxyy_CH2_RAL	%UXxx.yy.56	CH2 change rate alarm low limit flag	Read
_xxyy_CH2_RAH	%UXxx.yy.57	CH2 change rate alarm high limit flag	Read
_xxyy_CH3_RAL	%UXxx.yy.60	CH3 change rate alarm low limit flag	Read
_xxyy_CH3_RAH	%UXxx.yy.61	CH3 change rate alarm high limit flag	Read
_xxyy_CH0_TEMP	%UWxx.yy.4	CH 0 Temp. Conversion value	Read
_xxyy_CH1_TEMP	%UWxx.yy.5	CH 1 Temp. Conversion value	Read
_xxyy_CH2_TEMP	%UWxx.yy.6	CH 2 Temp. Conversion value	Read
_xxyy_CH3_TEMP	%UWxx.yy.7	CH 3 Temp. Conversion value	Read
_xxyy_CH0_SCAL	%UWxx.yy.8	CH 0 scaling operation value	Read
_xxyy_CH1_SCAL	%UWxx.yy.9	CH 1 scaling operation value	Read
_xxyy_CH2_SCAL	%UWxx.yy.10	CH 2 scaling operation value	Read
_xxyy_CH3_SCAL	%UWxx.yy.11	CH 3 scaling operation value	Read
_xxyy_CH0_MIN	%UWxx.yy.12	CH 0 Temp. conversion min. value	Read
_xxyy_CH0_MAX	%UWxx.yy.13	CH 0 Temp. conversion max. value	Read
_xxyy_CH1_MIN	%UWxx.yy.14	CH 1 Temp. conversion min. value	Read
_xxyy_CH1_MAX	%UWxx.yy.15	CH 1 Temp. conversion max. value	Read
_xxyy_CH2_MIN	%UWxx.yy.16	CH 2 Temp. conversion min. value	Read
_xxyy_CH2_MAX	%UWxx.yy.17	CH 2 Temp. conversion max. value	Read
_xxyy_CH3_MIN	%UWxx.yy.18	CH 3 Temp. conversion min. value	Read
_xxyy_CH3_MAX	%UWxx.yy.19	CH 3 Temp. conversion max. value	Read
_xxyy_CH0_TIME	%UDxx.yy.10	CH 0 data upload time	Read
_xxyy_CH1_TIME	%UDxx.yy.11	CH 1 data upload time	Read
_xxyy_CH2_TIME	%UDxx.yy.12	CH 2 data upload time	Read
_xxyy_CH3_TIME	%UDxx.yy.13	CH 3 data upload time	Read

[Table 7. 2] Command transferred from XGI/XGR PLC to module (XGI/XGR PLC output area)

Global variable	Memory assignment	Contents	Read/write
_xxyy_CH0_FINDEN	%UXxx.yy.464	CH0 max./min search function enable/disable	Read /Write
_xxyy_CH1_FINDEN	%UXxx.yy.465	CH1 max./min search function enable/disable	
_xxyy_CH2_FINDEN	%UXxx.yy.466	CH2 max./min search function enable/disable	
_xxyy_CH3_FINDEN	%UXxx.yy.467	CH3 max./min search function enable/disable	
_xxyy_CH0_FINDEN	%UXxx.yy.468	CH0 alarm function (process alarm/change rate alarm) enable/disable	
_xxyy_CH1_FINDEN	%UXxx.yy.469	CH1 alarm function (process alarm/change rate alarm) enable/disable	
_xxyy_CH2_FINDEN	%UXxx.yy.470	CH2 alarm function (process alarm/change rate alarm) enable/disable	
_xxyy_CH3_FINDEN	%UXxx.yy.471	CH3 alarm function (process alarm/change rate alarm) enable/disable	

※In device assignment, xx means base number module is equipped and yy means slot number module is equipped.

(2) How to use Global variable

There are two methods to register global variable. Automatic registration after I/O parameter setting at project window and batch registration after I/O parameter setting

(a) I/O parameter registration

- Registers the module at I/O parameter

1) Double-click I/O parameter of project window.

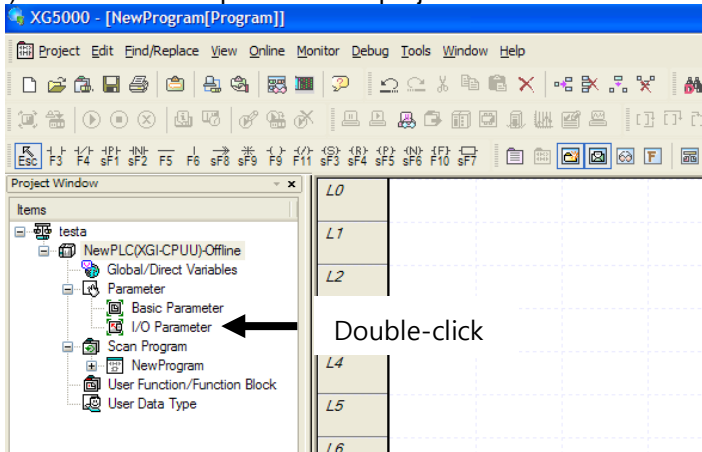

2) Select XGF-RD4A at I/O parameter window.

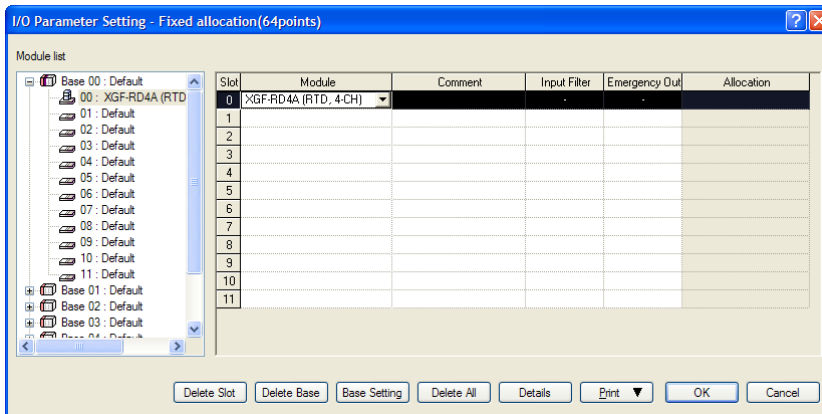

3) Set parameter by pressing [Detail]

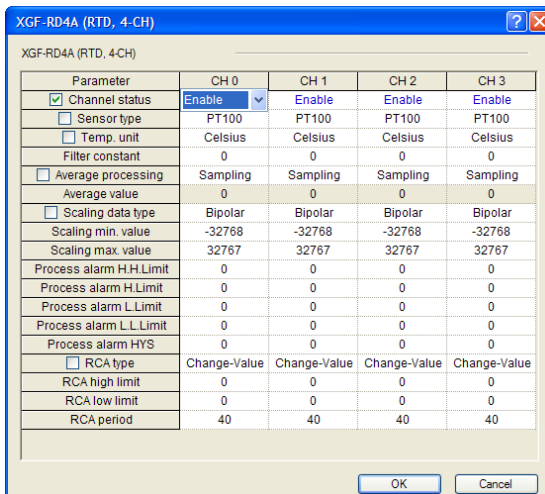

4) Select [Yes].

- Registers global variable of module set in I/O parameter

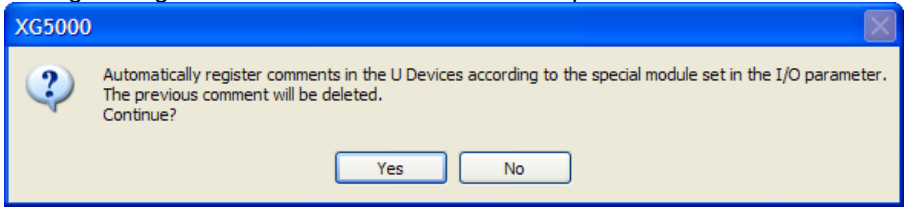

5) Checking automatic registration of global variable

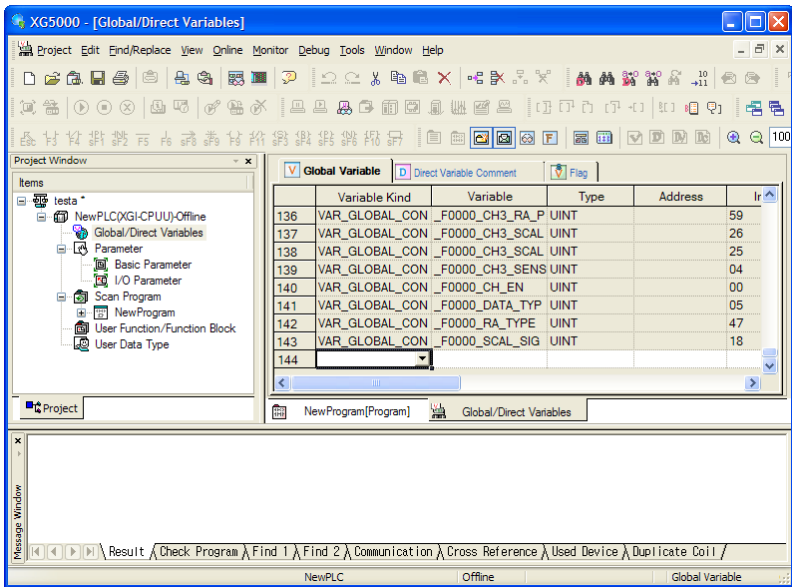
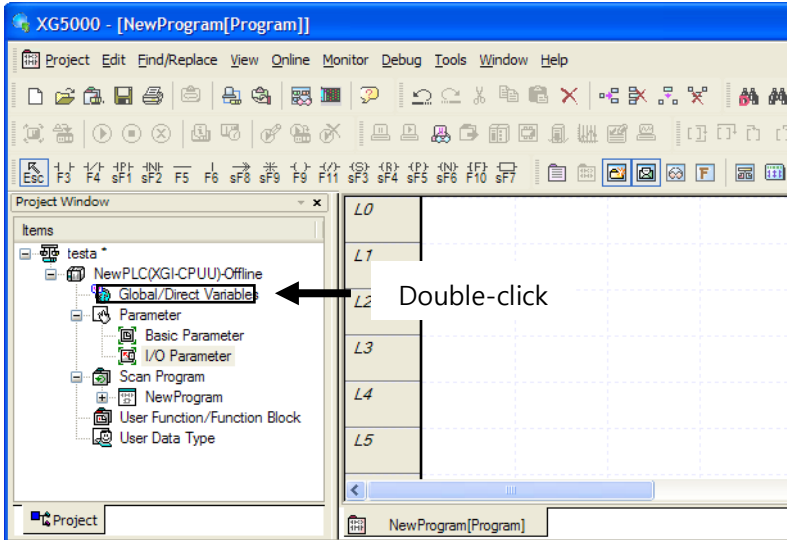

- (b) Global variable batch registration
- Registers global variable set in I/O parameter automatically
- 1) Double-click Global/Direct of project window

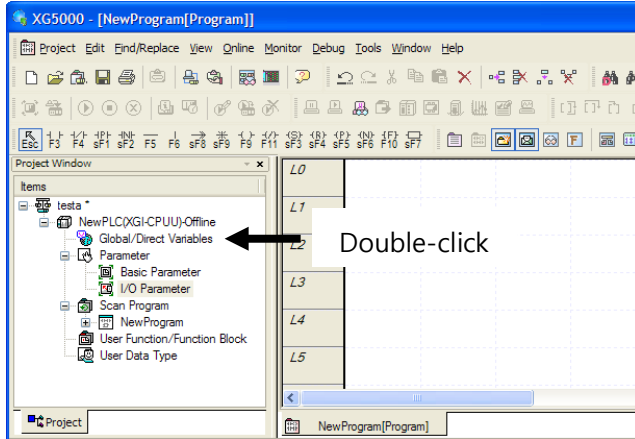

- 2) Select [Register Special Module Variables] on [Edit].

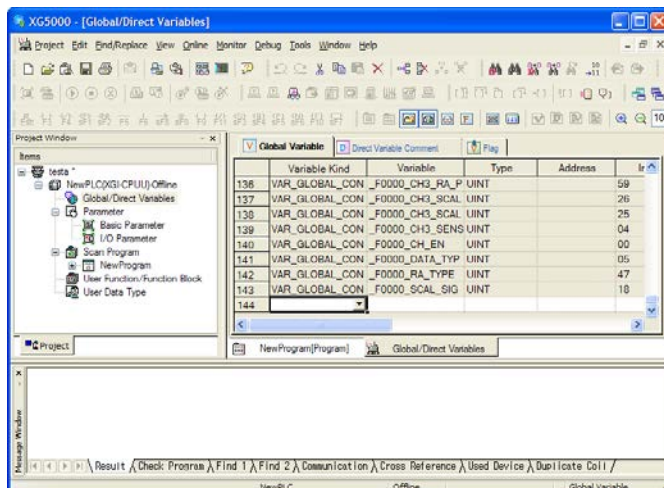
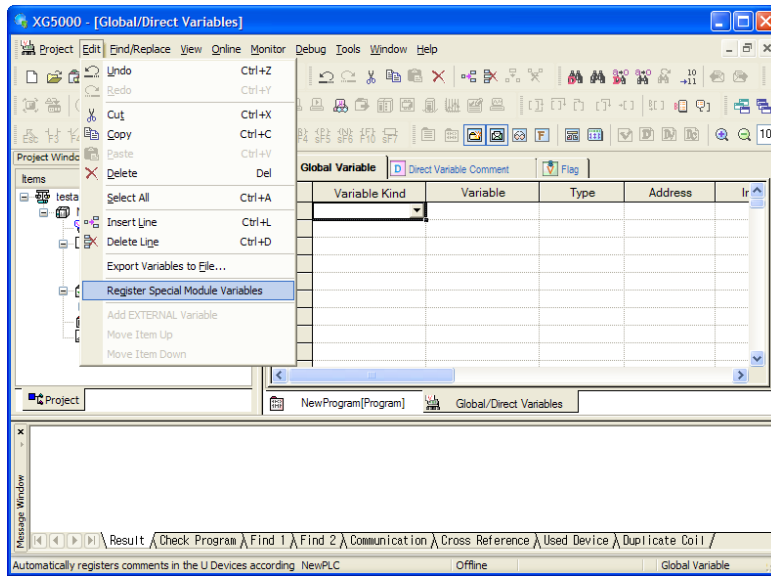

(c) Local variable registration

- Registers variable you want to use among global variables registered at (b) as local variable

1) At the following scan program, double-click local variable of program to use global variable

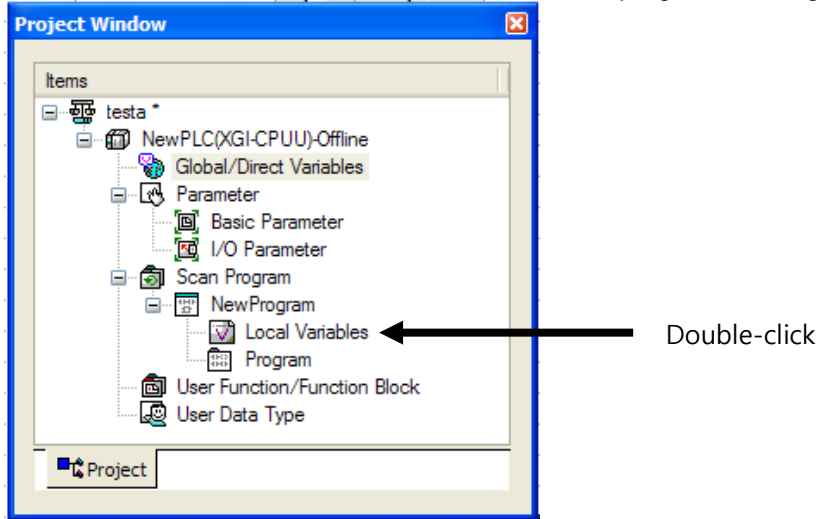

2) Click right button of mouse on the right local variable window and select "Add EXTERNAL variable"

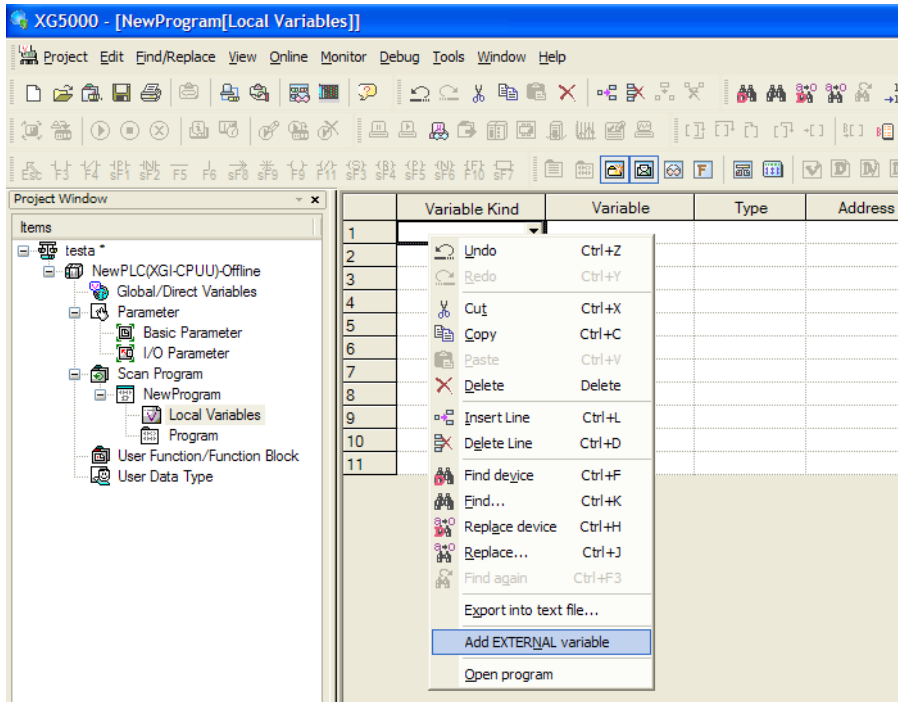

- 3) On the following “Add External Variable” window, select List of Global View as “All” or “Base xx, Slot yy”.
- All

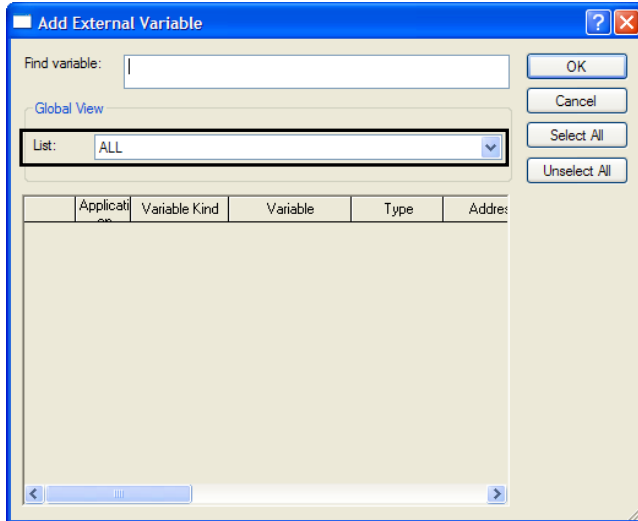

- Base xx, slot yy

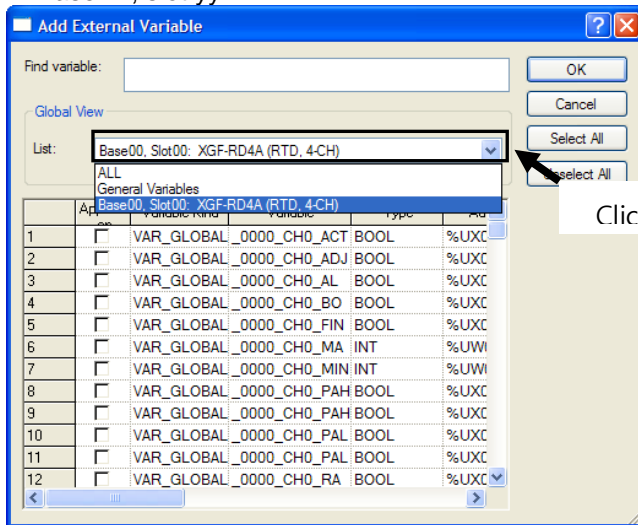

Click

- 4) The following figure is example when selecting CH 0 Temp. conversion value (_0000_CH0_TEMP) of Base 00, slot00

	Variable Kind	Variable	Type	Address	Initial Value	Retain	Used	
17	VAR_EXTERNAL	_0000_CH0_MAX	INT	%UW0.0.13		<input type="checkbox"/>	<input type="checkbox"/>	Temp. Measu
18	VAR_EXTERNAL	_0000_CH0_MIN	INT	%UW0.0.12		<input type="checkbox"/>	<input type="checkbox"/>	Temp. Measu
19	VAR_EXTERNAL	_0000_CH0_PAH	BOOL	%UX0.0.34		<input type="checkbox"/>	<input type="checkbox"/>	Temp. Measu
20	VAR_EXTERNAL	_0000_CH0_PAHH	BOOL	%UX0.0.35		<input type="checkbox"/>	<input type="checkbox"/>	Temp. Measu
21	VAR_EXTERNAL	_0000_CH0_PAL	BOOL	%UX0.0.33		<input type="checkbox"/>	<input type="checkbox"/>	Temp. Measu
22	VAR_EXTERNAL	_0000_CH0_PALL	BOOL	%UX0.0.32		<input type="checkbox"/>	<input type="checkbox"/>	Temp. Measu
23	VAR_EXTERNAL	_0000_CH0_RAH	BOOL	%UX0.0.49		<input type="checkbox"/>	<input type="checkbox"/>	Temp. Measu
24	VAR_EXTERNAL	_0000_CH0_RAL	BOOL	%UX0.0.48		<input type="checkbox"/>	<input type="checkbox"/>	Temp. Measu
25	VAR_EXTERNAL	_0000_CH0_SCAL	INT	%UW0.0.8		<input type="checkbox"/>	<input type="checkbox"/>	Temp. Measu
26	VAR_EXTERNAL	_0000_CH0_SETER	BOOL	%UX0.0.24		<input type="checkbox"/>	<input type="checkbox"/>	Temp. Measu
27	VAR_EXTERNAL	_0000_CH0_TEMP	INT	%UW0.0.4		<input type="checkbox"/>	<input type="checkbox"/>	Temp. Measu
28	VAR_EXTERNAL	_0000_CH0_TIME	UDINT	%UD0.0.10		<input type="checkbox"/>	<input type="checkbox"/>	Temp. Measu
29	VAR_EXTERNAL	_0000_CH1_ACT	BOOL	%UX0.0.17		<input type="checkbox"/>	<input type="checkbox"/>	Temp. Measu
30	VAR_EXTERNAL	_0000_CH1_ADJER	BOOL	%UX0.0.1		<input type="checkbox"/>	<input type="checkbox"/>	Temp. Measu
31	VAR_EXTERNAL	_0000_CH1_ALME	BOOL	%UX0.0.469		<input type="checkbox"/>	<input type="checkbox"/>	Temp. Measu

(d) How to use local variable at program

- Here describes how to use added global variable at local program.
- The following is example saving CH0 temp. conversion value in %MW0 area.

1) Double-click variable part in front of IN and open “Select Variable” window by using the following MOVE function

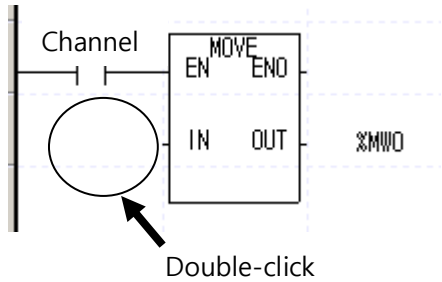

2) On the “Variable List”, select “Global Variable” and on the “List”, select relevant base (Base 0, Slot 0).

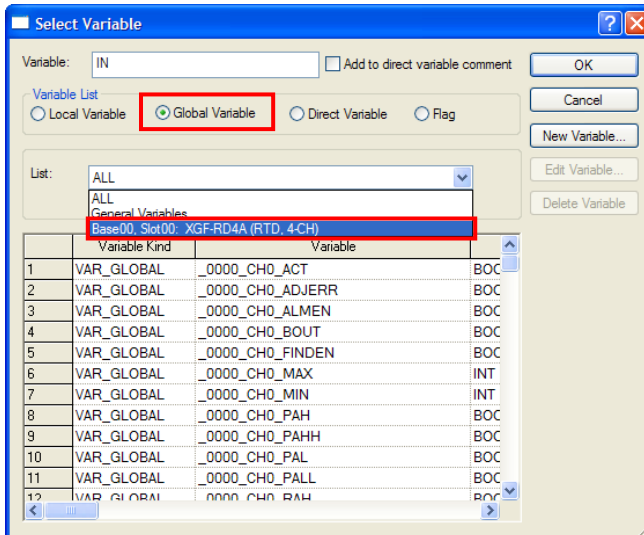

3) Double-click or select `_000_CH0_TEMP` relevant to CH0 Temp. conversion value and press [OK].

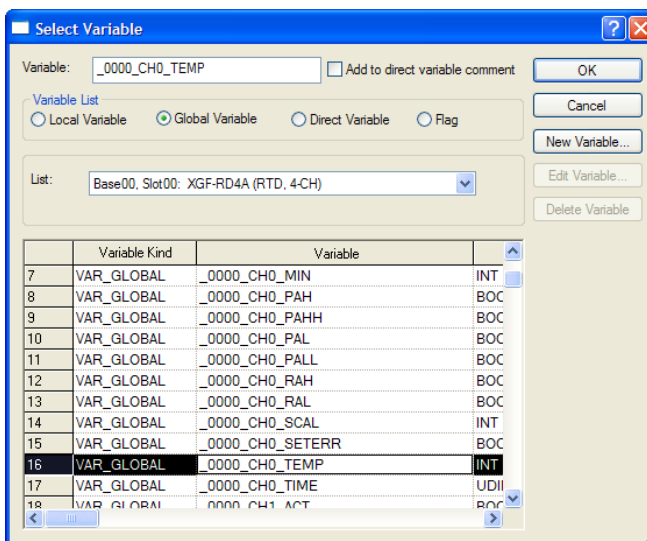

4)The following figure is result adding global variable relevant to CH0 Temp. Conversion value.

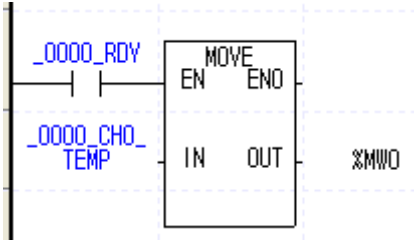

7.1.2 Area using PUT/GET Function Block (Parameter Area)

(1) Area using PUT/GET Function Block (Parameter Area)

Operation parameter setting area of D/A conversion module is displayed at Table 7.3

[Table 7. 2] Operation parameter setting area

Global Variable	Contents	Read/Write	Instruction
_Fxxyy_CH_EN	Enable channel	Read/Write	PUT/GET
_Fxxyy_CH0_SENSOR	CH 0 sensor type setting	Read/Write	PUT/GET
_Fxxyy_CH1_SENSOR	CH 1 sensor type setting		
_Fxxyy_CH2_SENSOR	CH 2 sensor type setting		
_Fxxyy_CH3_SENSOR	CH 3 sensor type setting		
_Fxxyy_DATA_TYPE	Temp. unit setting	Read/Write	PUT/GET
_Fxxyy_CH0_FILT_CONST	CH0 filter value setting	Read/Write	PUT/GET
_Fxxyy_CH1_FILT_CONST	CH1 filter value setting		
_Fxxyy_CH2_FILT_CONST	CH2 filter value setting		
_Fxxyy_CH3_FILT_CONST	CH3 filter value setting		
_Fxxyy_CH0_AVG_SEL	CH0 average method setting	Read/Write	PUT/GET
_Fxxyy_CH1_AVG_SEL	CH1 average method setting		
_Fxxyy_CH2_AVG_SEL	CH2 average method setting		
_Fxxyy_CH3_AVG_SEL	CH3 average method setting		
_Fxxyy_CH0_AVG_VAL	CH0 average value setting	Read/Write	PUT/GET
_Fxxyy_CH1_AVG_VAL	CH1 average value setting		
_Fxxyy_CH2_AVG_VAL	CH2 average value setting		
_Fxxyy_CH3_AVG_VAL	CH3 average value setting		
_Fxxyy_SCAL_SIGN	Scaling type setting	Read/Write	PUT/GET
_Fxxyy_CH0_SCAL_MIN	CH0 scaling min. value setting	-32768	PUT/GET
_Fxxyy_CH0_SCAL_MAX	CH0 scaling max. value setting	32767	
_Fxxyy_CH1_SCAL_MIN	CH1 scaling min. value setting	-32768	
_Fxxyy_CH1_SCAL_MAX	CH1 scaling max. value setting	32767	
_Fxxyy_CH2_SCAL_MIN	CH2 scaling min. value setting	-32768	
_Fxxyy_CH2_SCAL_MAX	CH2 scaling max. value setting	32767	
_Fxxyy_CH3_SCAL_MIN	CH3 scaling min. value setting	-32768	
_Fxxyy_CH3_SCAL_MAX	CH3 scaling max. value setting	32767	

※In device assignment, xx means base number module is equipped and yy means slot number module is equipped.

Global Variable	Contents	Read/Write	Instruction
_Fxyy_CH0_PAHH_VAL	CH0 process alarm high-high limit setting	Read/Write	PUT/GET
_Fxyy_CH0_PAH_VAL	CH0 process alarm high limit setting	Read/Write	PUT/GET
_Fxyy_CH0_PAL_VAL	CH0 process alarm low limit setting		
_Fxyy_CH0_PALL_VAL	CH0 process alarm low-low limit setting		
_Fxyy_CH1_PAHH_VAL	CH1 process alarm high-high limit setting		
_Fxyy_CH1_PAH_VAL	CH1 process alarm high limit setting		
_Fxyy_CH1_PAL_VAL	CH1 process alarm low limit setting		
_Fxyy_CH1_PALL_VAL	CH1 process alarm low-low limit setting		
_Fxyy_CH2_PAHH_VAL	CH2 process alarm high-high limit setting		
_Fxyy_CH2_PAH_VAL	CH2 process alarm high limit setting		
_Fxyy_CH2_PAL_VAL	CH2 process alarm low limit setting		
_Fxyy_CH2_PALL_VAL	CH2 process alarm low-low limit setting		
_Fxyy_CH3_PAHH_VAL	CH3 process alarm high-high limit setting		
_Fxyy_CH3_PAH_VAL	CH3 process alarm high limit setting		
_Fxyy_CH3_PAL_VAL	CH3 process alarm low limit setting		
_Fxyy_CH3_PALL_VAL	CH3 process alarm low-low limit setting		
_Fxyy_CH0_PA_HYS	CH0 process alarm hysteresis setting	Read/Write	PUT/GET
_Fxyy_CH1_PA_HYS	CH1 process alarm hysteresis setting	Read/Write	PUT/GET
_Fxyy_CH2_PA_HYS	CH2 process alarm hysteresis setting		
_Fxyy_CH3_PA_HYS	CH3 process alarm hysteresis setting		
_Fxyy_RA_TYPE	Setting type of change rate alarm		
_Fxyy_CH0_RAH_VAL	CH0 change rate alarm high limit setting	Read/Write	PUT/GET
_Fxyy_CH0_RAL_VAL	CH0 change rate alarm low limit setting	Read/Write	PUT/GET
_Fxyy_CH1_RAH_VAL	CH1 change rate alarm high limit setting		
_Fxyy_CH1_RAL_VAL	CH1 change rate alarm low limit setting		
_Fxyy_CH2_RAH_VAL	CH2 change rate alarm high limit setting		
_Fxyy_CH2_RAL_VAL	CH2 change rate alarm low limit setting		
_Fxyy_CH3_RAH_VAL	CH3 change rate alarm high limit setting		
_Fxyy_CH3_RAL_VAL	CH3 change rate alarm low limit setting		
_Fxyy_CH0_RA_PERIOD	CH0 change rate alarm detection period setting	Read/Write	PUT/GET
_Fxyy_CH1_RA_PERIOD	CH1 change rate alarm detection period setting	Read/Write	PUT/GET
_Fxyy_CH2_RA_PERIOD	CH2 change rate alarm detection period setting		
_Fxyy_CH3_RA_PERIOD	CH3 change rate alarm detection period setting		

(2) Other data monitor area (Using GET/GETP)

Global Variable	Contents	Read/Write	Instruction
_Fxyy_CH0_ERR_CODE	CH0 setting error information (flag)	Read	GET
_Fxyy_CH1_ERR_CODE	CH1 setting error information (flag)		
_Fxyy_CH2_ERR_CODE	CH2 setting error information (flag)		
_Fxyy_CH3_ERR_CODE	CH3 setting error information (flag)		
_Fxyy_CH0_RAVAL	CH0 input change value (change rate alarm function data)	Read	GET
_Fxyy_CH1_RAVAL	CH1 input change value (change rate alarm function data)		
_Fxyy_CH2_RAVAL	CH2 input change value (change rate alarm function data)		
_Fxyy_CH3_RAVAL	CH3 input change value (change rate alarm function data)		
_Fxyy_CH0_BOUT_CODE	CH0 disconnection information (code)	Read	GET
_Fxyy_CH1_BOUT_CODE	CH1 disconnection information (code)		
_Fxyy_CH2_BOUT_CODE	CH2 disconnection information (code)		
_Fxyy_CH3_BOUT_CODE	CH3 disconnection information (code)		

(3) PUT/GET instruction

(a) PUT instruction

<h1>PUT</h1>
Writing data to special module

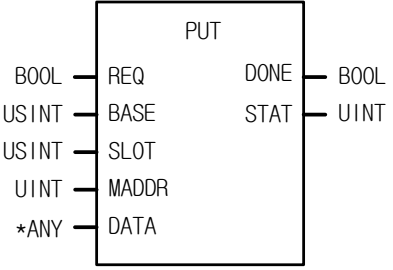
Function Block	Description
	<p>INPUT</p> <p>REQ: When it's 1, function is executed BASE : Base location SLOT : Slot location MADDR : Module address DATA : Data to save at module</p> <p>OUTPUT</p> <p>DONE : If normally executed, 1 is outputted STAT : Error information</p>

*ANY: WORD, DWORD, INT, USINT, DINT, UDINT are available among ANY type

■ **Function**

Reads data from the designated special module

Function Block	Input (ANY) type	Operation description
PUT_WORD	WORD	Saves WORD data at the designated module address (MADDR)
PUT_DWORD	DWORD	Saves DWORD data at the designated module address (MADDR)
PUT_INT	INT	Saves INT data at the designated module address (MADDR)
PUT_UINT	UINT	Saves UINT data at the designated module address (MADDR)
PUT_DINT	DINT	Saves DINT data at the designated module address (MADDR)
PUT_UDINT	UDINT	Saves UDINT data at the designated module address (MADDR)

(b) GET instruction

GET
Reading data from special module

Function Block	Description
	<p>INPUT</p> <p>REQ: When it's 1, function is executed BASE : Base location SLOT : Slot location MADDR : Nodule address 512(0x200) ~ 1023(0x3FF)</p> <p>OUTPUT</p> <p>DONE : If normally executed, 1 is outputted STAT : Error information DATA : Data read from module</p>

*ANY: WORD, DWORD, INT, UINT, DINT, UDINT are available among ANY type

■ **Function**

Reads data from the designated special module

Function Block	Output (ANY) type	Operation description
GET_WORD	WORD	Reads WORD data from the designated module address (MADDR)
GET_DWORD	DWORD	Reads DWORD data from the designated module address (MADDR)
GET_INT	INT	Reads INT data from the designated module address (MADDR)
GET_UINT	UINT	Reads UINT data from the designated module address (MADDR)
GET_DINT	DINT	Reads DINT data from the designated module address (MADDR)
GET_UDINT	UDINT	Reads UDINT data from the designated module address (MADDR)

(4) Example of PUT/GET instruction

(a) Enable channel

- 1) You can enable/disable every channel respectively.
- 2) Disable the unused channel to reduce the conversion period.
- 3) Default is all channels are disabled.
- 4) Enable/Disable of temp. conversion is as follows.

B15	B14	B13	B12	B11	B10	B9	B8	B7	B6	B5	B4	B3	B2	B1	B0
—	—	—	—	—	—	—	—	—	—	—	—	C	C	C	C
												H	H	H	H
												3	2	1	0

Bit	Description
0	Disabled
1	Enabled

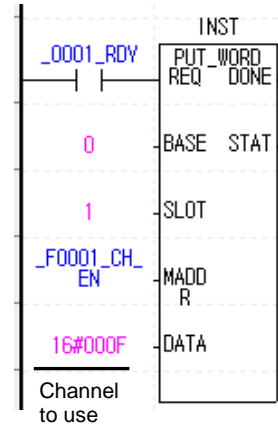
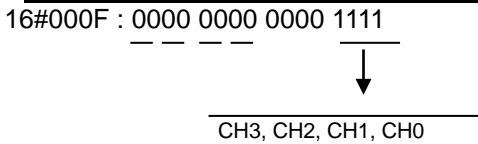

- 5) The values set in B4~B15 are ignored.
- 6) On the right figure, CH0~CH3 of module equipped at slot 1 are enabled.

(b) Sensor type setting

- 1) Sets sensor type about type of input sensor
- 2) If out of set value is inputted, setting error occurs and that is set as "0".

B15	B14	B13	B12	B11	B10	B9	B8	B7	B6	B5	B4	B3	B2	B1	B0
CH# sensor type setting															

Word value	Description
0	PT100
1	JPT100

Word value	Description
0	3-wired PT100
1	3-wired JPT100
2	3-wired PT1000
3	3-wired JI100
4	4-wired PT100
5	4-wired JPT100
6	4-wired PT1000
7	4-wired JI100

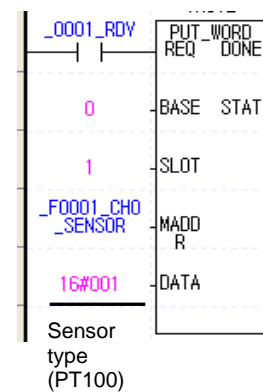

(c) Temperature conversion unit setting

1) Temperature-converted value can be output in °C or °F as specified.

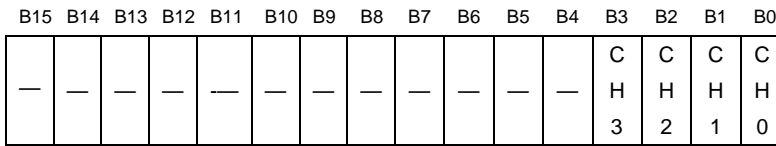

Bit	Description
0	Celsius
1	Fahrenheit

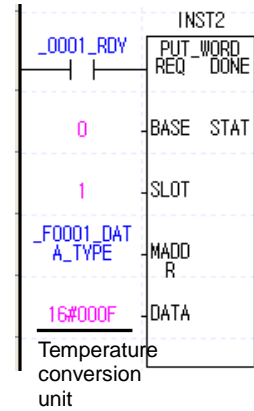
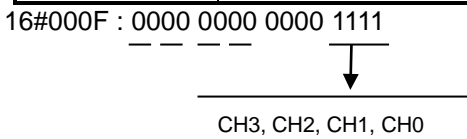

- 2) The values set in B4~B15 are ignored.
- 3) On the right figure, CH0~CH3 of module equipped at slot 1 are set as Fahrenheit.

(d) Filter value setting

- 1) If filter values set "0", designated channels output temperature conversion value not executing filter value but executing sampling value.
- 2) if filter values set 1 to 319 or more than 64001, filter values set to "0" and module occurs to setting error.

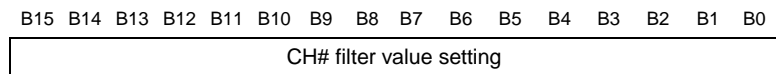

Setting range : 320~64000ms

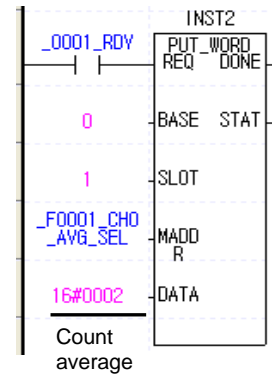

(e) Average method setting

- 1) If average method values set more than 4, average method values set to "0" and module occurs to setting error.
- 2) If input more than 3, it is displayed in a setting error and setting value is set to "0"

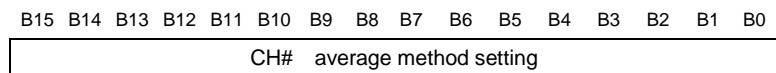

Word	Description
0	Sampling
1	Time averaging
2	Count averaging
3	Moving averaging

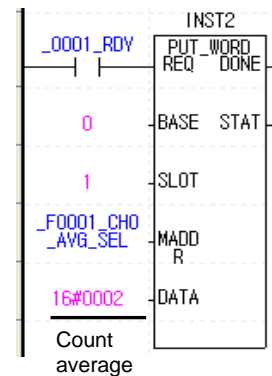

(f) Average value setting

- 1) If averaging method is sampling, this area is ignored.
- 2) If average value is out of setting range, error occurs and that is set as maximum or minimum value
 Ex) If you select time averaging and set average value as 200, setting error occurs and that is set as 320

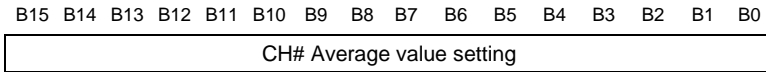

Item	Setting value
Time averaging	320~64000[ms]
Count averaging	2~64000[times]
Moving averaging	2~100[unit]

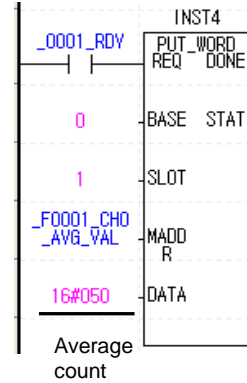

(g) Scale type setting

- 1) If relevant bit is "1", output data range by scaling operation will be "0~65535".
- 2) If relevant bit is "0", output data range by scaling operation will be "-32768~32767"(default)

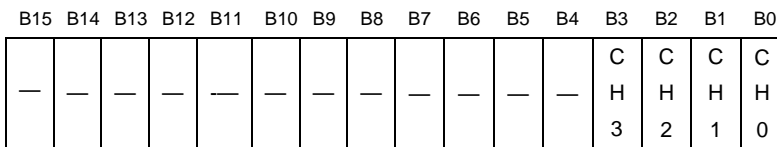

Bit	description
0	Signed scaling range
1	Unsigned scaling range

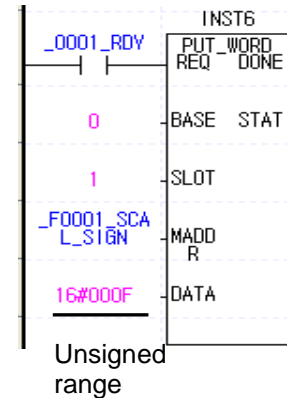
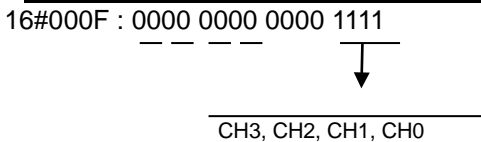

(h) Setting of max/min value of scaling range

- 1) If it is out of range, setting error occurs and it is not changed.

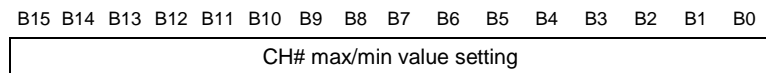

Item	Setting value
Signed type	-32,768 ~ 32,767
Unsigned type	0 ~ 65535

Scaling max/min setting

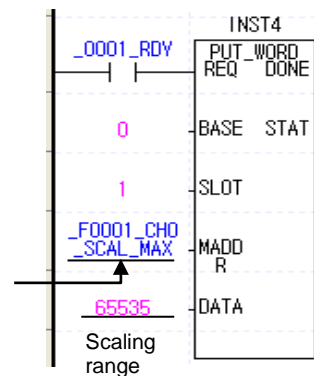

(i) Process alarm boundary value setting

- 1) Setting range can be set according to output temperature type (Celsius/Fahrenheit) and sensor type (Pt100/JPt100) differently.
- 2) If it is out of range, setting error occurs and it is not changed.

B15 B14 B13 B12 B11 B10 B9 B8 B7 B6 B5 B4 B3 B2 B1 B0
 CH# Process alarm boundary value setting

Item		Setting value
PT100	Celsius	-2000 ~ 8500
	Fahrenheit	-3280 ~ 15620
JPT100	Celsius	-2000 ~ 6400
	Fahrenheit	-3280 ~ 11840

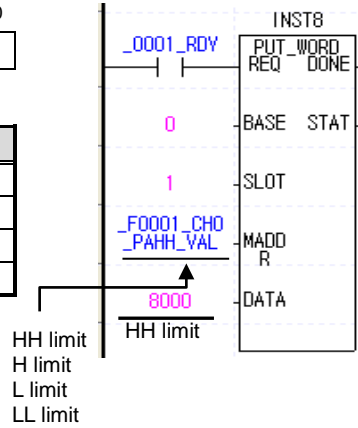

(j) Process alarm hysteresis setting

- 1) If it is out of range, setting error occurs and it is not changed.
- 2) When using process alarm and it meets clear condition of alarm, if it is within the hysteresis setting range, the alarm output keeps

B15 B14 B13 B12 B11 B10 B9 B8 B7 B6 B5 B4 B3 B2 B1 B0
 CH# alarm hysteresis setting

Setting value
0 ~ 1000

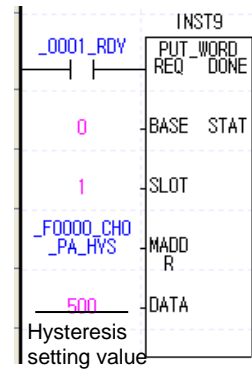

(k) Change rate alarm setting type setting

- 1) Relevant bit is set as "1", change rate alarm is used as standard of alarm output. Change rate means the rate of input range according to sensor type.

Example) change rate in case of PT100

$$\text{Change rate[\%]} = \frac{(\text{Current temp.} - \text{alarm previous temp.}) \times 100}{(8500 - (-2000))}$$

- 2) In case it is set as "0", temp. change value is used as standard of alarm output

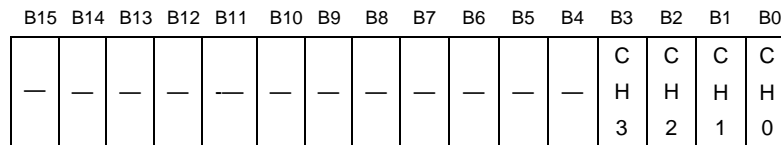

Bit	Description
0	Temp. change value
1	Temp. change rate

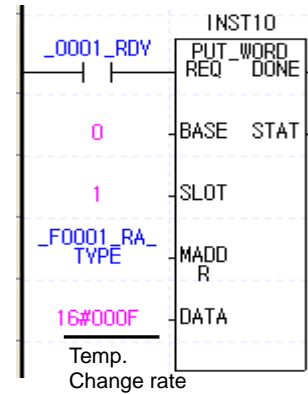
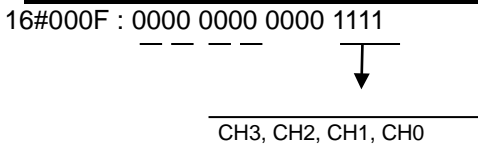

(l) Change rate alarm high limit/low limit boundary value setting

- 1) If it is out of range, setting error occurs and it is set as "0".
- 2) In case of temp. change rate, it becomes percent value indicating first decimal point
- 3) In case alarm setting value type of change rate alarm is temp. change value, unit of this value is temp.

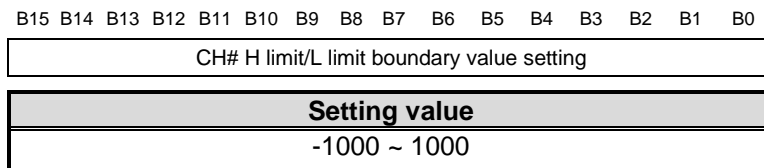

H limit
L limit
setting

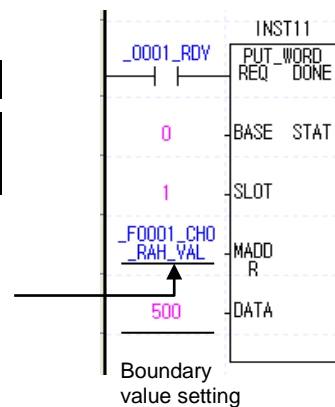

(m) Change rate alarm detection period setting

- 1) Setting period to detecting change rate when using change rate alarm function.
- 2) If it is out of range, setting error occurs and it is set as "40".

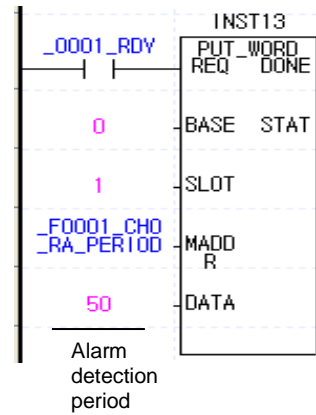
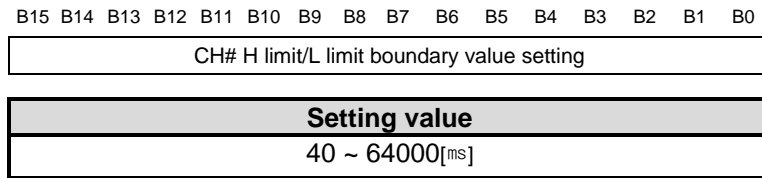

(n) Channel error information output

- 1) If it is out of range (in case of setting by program), relevant bit becomes "1"
- 2) Setting error is clear off when you set the value again to be in the range.
- 3) In case of setting error, there is no LEC indication. When bits of Uxy.01.08~Uxy.01.0B are on, check the relevant setting.
- 4) Relevant setting address and error contents for each bit
 - Bit 0: Channel sensor type setting error
 - Bit 1: Channel filter value setting error
 - Bit 2: Channel average type setting error
 - Bit 3: Channel average value setting error
 - Bit 4: Channel scale min. range setting error
 - Bit 5: Channel scale max. range setting error
 - Bit 6: Channel process alarm HH limit setting error
 - Bit 7: Channel process alarm H limit setting error
 - Bit 8: Channel process alarm L limit setting error
 - Bit 9: Channel process alarm LL limit setting error
 - Bit A: Channel process alarm hysteresis setting error
 - Bit B: Channel change rate alarm setting error
 - Bit C: Channel change rate alarm L limit setting error
 - Bit D: Channel change rate alarm detection period setting error

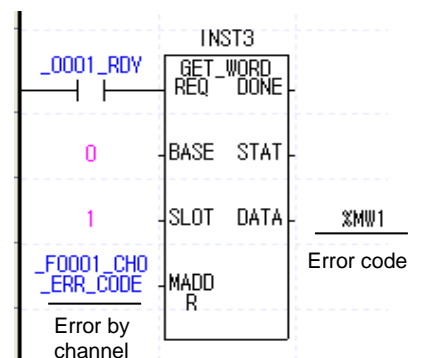
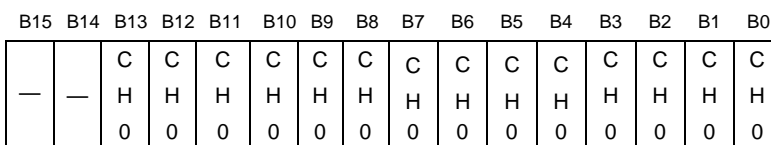

(o) Change rate alarm conversion value output

- 1) During the designated detection period, it outputs changed input (temp. value) or change rate (percentage according to sensor range)

Output range		
Change rate		-1023 ~ 1023
Change value	PT100	-10700 ~ 10700
	JPT	-8600 ~ 8600

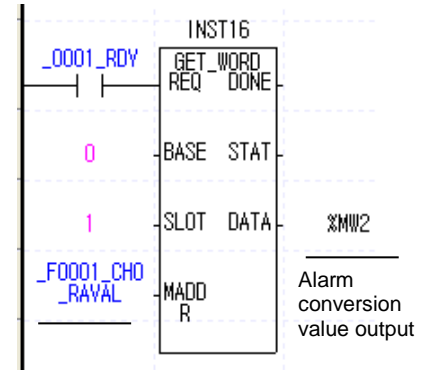

Indication by channel

(p) Sensor disconnection information output

- 1) Area outputting disconnection detection information

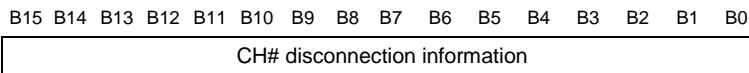

2) Setting value

- XGF-RD4A

(0:normal, 1:sensor A disconnection, 2:sensor B disconnection)

- XGF-RD4S

(0:normal, 1:sensor disconnection)

-

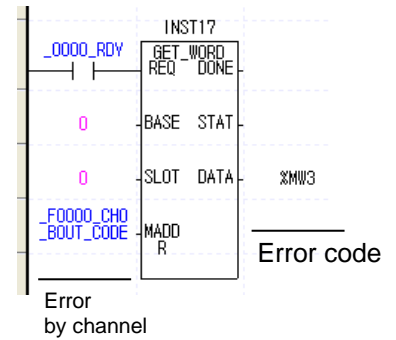

7.2 XGF-RD8A

7.2.1 Global variable (Data area)

(1) Conversion data I/O area

Temperature conversion data I/O area is indicated at table 7.4

[Table 7. 4] conversion data I/O area

Global variable	Memory assignment	Contents	Read/write
_xxyy_CH0_ADJERR	%UXxx.yy.0	CH 0 offset/gain adjustment error	Read
_xxyy_CH1_ADJERR	%UXxx.yy.1	CH 1 offset/gain adjustment error	
_xxyy_CH2_ADJERR	%UXxx.yy.2	CH 2 offset/gain adjustment error	
_xxyy_CH3_ADJERR	%UXxx.yy.3	CH 3 offset/gain adjustment error	
_xxyy_CH4_ADJERR	%UXxx.yy.4	CH 4 offset/gain adjustment error	
_xxyy_CH5_ADJERR	%UXxx.yy.5	CH 5 offset/gain adjustment error	
_xxyy_CH6_ADJERR	%UXxx.yy.6	CH 6 offset/gain adjustment error	
_xxyy_CH7_ADJERR	%UXxx.yy.7	CH 7 offset/gain adjustment error	
_xxyy_EEPROMERR	%UXxx.yy.13	Offset /Gain backup error	
_xxyy_WDT_ERR	%UXxx.yy.14	Module H/W error	
_xxyy_RDY	%UXxx.yy.15	Module Ready	Read
_xxyy_CH0_ACT	%UXxx.yy.16	CH 0 Operating	
_xxyy_CH1_ACT	%UXxx.yy.17	CH 1 Operating	
_xxyy_CH2_ACT	%UXxx.yy.18	CH 2 Operating	
_xxyy_CH3_ACT	%UXxx.yy.19	CH 3 Operating	
_xxyy_CH4_ACT	%UXxx.yy.20	CH 4 Operating	
_xxyy_CH5_ACT	%UXxx.yy.21	CH 5 Operating	
_xxyy_CH6_ACT	%UXxx.yy.22	CH 6 Operating	
_xxyy_CH7_ACT	%UXxx.yy.23	CH 7 Operating	Read
_xxyy_CH0_BOUT	%UXxx.yy.24	CH 0 disconnection	
_xxyy_CH1_BOUT	%UXxx.yy.25	CH 1 disconnection	
_xxyy_CH2_BOUT	%UXxx.yy.26	CH 2 disconnection	
_xxyy_CH3_BOUT	%UXxx.yy.27	CH 3 disconnection	
_xxyy_CH4_BOUT	%UXxx.yy.28	CH 4 disconnection	
_xxyy_CH5_BOUT	%UXxx.yy.29	CH 5 disconnection	
_xxyy_CH6_BOUT	%UXxx.yy.30	CH 6 disconnection	
_xxyy_CH7_BOUT	%UXxx.yy.31	CH 7 disconnection	Read
_xxyy_CH0_SETERR	%UXxx.yy.32	CH 0 setting error	
_xxyy_CH1_SETERR	%UXxx.yy.33	CH 1 setting error	
_xxyy_CH2_SETERR	%UXxx.yy.34	CH 2 setting error	
_xxyy_CH3_SETERR	%UXxx.yy.35	CH 3 setting error	
_xxyy_CH4_SETERR	%UXxx.yy.36	CH 4 setting error	
_xxyy_CH5_SETERR	%UXxx.yy.37	CH 5 setting error	
_xxyy_CH6_SETERR	%UXxx.yy.38	CH 6 setting error	
_xxyy_CH7_SETERR	%UXxx.yy.39	CH 7 setting error	

[Table 7. 4] conversion data I/O area

Global variable	Memory assignment	Contents	Read/write
_xxyy_CH0_RALL	%UXxx.yy.48	CH0 process alarm low-low limit flag	Read
_xxyy_CH0_RAL	%UXxx.yy.49	CH0 process alarm low limit flag	
_xxyy_CH0_RAH	%UXxx.yy.50	CH0 process alarm high limit flag	
_xxyy_CH0_RAHH	%UXxx.yy.51	CH0 process alarm high-high limit flag	
_xxyy_CH1_RALL	%UXxx.yy.52	CH1 process alarm low-low limit flag	
_xxyy_CH1_RAL	%UXxx.yy.53	CH1 process alarm low limit flag	
_xxyy_CH1_RAH	%UXxx.yy.54	CH1 process alarm high limit flag	
_xxyy_CH1_RAHH	%UXxx.yy.55	CH1 process alarm high-high limit flag	
_xxyy_CH2_RALL	%UXxx.yy.56	CH2 process alarm low-low limit flag	
_xxyy_CH2_RAL	%UXxx.yy.57	CH2 process alarm low limit flag	
_xxyy_CH2_RAH	%UXxx.yy.58	CH2 process alarm high limit flag	
_xxyy_CH2_RAHH	%UXxx.yy.59	CH2 process alarm high-high limit flag	
_xxyy_CH3_RALL	%UXxx.yy.60	CH3 process alarm low-low limit flag	
_xxyy_CH3_RAL	%UXxx.yy.61	CH3 process alarm low limit flag	
_xxyy_CH3_RAH	%UXxx.yy.62	CH3 process alarm high limit flag	
_xxyy_CH3_RAHH	%UXxx.yy.63	CH3 process alarm high-high limit flag	
_xxyy_CH4_RALL	%UXxx.yy.64	CH4 process alarm low-low limit flag	
_xxyy_CH4_RAL	%UXxx.yy.65	CH4 process alarm low limit flag	
_xxyy_CH4_RAH	%UXxx.yy.66	CH4 process alarm high limit flag	
_xxyy_CH4_RAHH	%UXxx.yy.67	CH4 process alarm high-high limit flag	
_xxyy_CH5_RALL	%UXxx.yy.68	CH5 process alarm low-low limit flag	
_xxyy_CH5_RAL	%UXxx.yy.69	CH5 process alarm low limit flag	
_xxyy_CH5_RAH	%UXxx.yy.70	CH5 process alarm high limit flag	
_xxyy_CH5_RAHH	%UXxx.yy.71	CH5 process alarm high-high limit flag	
_xxyy_CH6_RALL	%UXxx.yy.72	CH6 process alarm low-low limit flag	
_xxyy_CH6_RAL	%UXxx.yy.73	CH6 process alarm low limit flag	
_xxyy_CH6_RAH	%UXxx.yy.74	CH6 process alarm high limit flag	
_xxyy_CH6_RAHH	%UXxx.yy.75	CH6 process alarm high-high limit flag	
_xxyy_CH7_RALL	%UXxx.yy.76	CH7 process alarm low-low limit flag	
_xxyy_CH7_RAL	%UXxx.yy.77	CH7 process alarm low limit flag	
_xxyy_CH7_RAH	%UXxx.yy.78	CH7 process alarm high limit flag	
_xxyy_CH7_RAHH	%UXxx.yy.79	CH7 process alarm high-high limit flag	

[Table 7. 4] conversion data I/O area

Global variable	Memory assignment	Contents	Read/write
_xxyy_CH0_RAL	%UXxx.yy.80	CH0 change rate alarm low limit flag	Read
_xxyy_CH0_RAH	%UXxx.yy.81	CH0 change rate alarm high limit flag	
_xxyy_CH1_RAL	%UXxx.yy.82	CH1 change rate alarm low limit flag	
_xxyy_CH1_RAH	%UXxx.yy.83	CH1 change rate alarm high limit flag	
_xxyy_CH2_RAL	%UXxx.yy.84	CH2 change rate alarm low limit flag	
_xxyy_CH2_RAH	%UXxx.yy.85	CH2 change rate alarm high limit flag	
_xxyy_CH3_RAL	%UXxx.yy.86	CH3 change rate alarm low limit flag	
_xxyy_CH3_RAH	%UXxx.yy.87	CH3 change rate alarm high limit flag	
_xxyy_CH4_RAL	%UXxx.yy.88	CH4 change rate alarm low limit flag	
_xxyy_CH4_RAH	%UXxx.yy.89	CH4 change rate alarm high limit flag	
_xxyy_CH5_RAL	%UXxx.yy.90	CH5 change rate alarm low limit flag	
_xxyy_CH5_RAH	%UXxx.yy.91	CH5 change rate alarm high limit flag	
_xxyy_CH6_RAL	%UXxx.yy.92	CH6 change rate alarm low limit flag	
_xxyy_CH6_RAH	%UXxx.yy.93	CH6 change rate alarm high limit flag	
_xxyy_CH7_RAL	%UXxx.yy.93	CH7 change rate alarm low limit flag	
_xxyy_CH7_RAH	%UXxx.yy.95	CH7 change rate alarm high limit flag	
_xxyy_CH0_TEMP	%UWxx.yy.6	CH0 temperature conversion value	
_xxyy_CH1_TEMP	%UWxx.yy.7	CH1 temperature conversion value	
_xxyy_CH2_TEMP	%UWxx.yy.8	CH2 temperature conversion value	
_xxyy_CH3_TEMP	%UWxx.yy.9	CH3 temperature conversion value	
_xxyy_CH4_TEMP	%UWxx.yy.10	CH4 temperature conversion value	
_xxyy_CH5_TEMP	%UWxx.yy.11	CH5 temperature conversion value	
_xxyy_CH6_TEMP	%UWxx.yy.12	CH6 temperature conversion value	
_xxyy_CH7_TEMP	%UWxx.yy.13	CH7 temperature conversion value	
_xxyy_CH0_SCAL	%UWxx.yy.14	CH0 scaling operation value	
_xxyy_CH1_SCAL	%UWxx.yy.15	CH1 scaling operation value	
_xxyy_CH2_SCAL	%UWxx.yy.16	CH2 scaling operation value	
_xxyy_CH3_SCAL	%UWxx.yy.17	CH3 scaling operation value	
_xxyy_CH4_SCAL	%UWxx.yy.18	CH4 scaling operation value	
_xxyy_CH5_SCAL	%UWxx.yy.19	CH5 scaling operation value	
_xxyy_CH6_SCAL	%UWxx.yy.20	CH6 scaling operation value	
_xxyy_CH7_SCAL	%UWxx.yy.21	CH7 scaling operation value	

[Table 7. 5] Command transferred from XGI/XGR PLC to module (XGI/XGR PLC output area)

Global variable	Memory assignment	Contents	Read/write
_xxyy_CH0_FINDEN	%UXxx.yy.352	CH0 max./min search function enable/disable	Read /Write
_xxyy_CH1_FINDEN	%UXxx.yy.353	CH1 max./min search function enable/disable	
_xxyy_CH2_FINDEN	%UXxx.yy.354	CH2 max./min search function enable/disable	
_xxyy_CH3_FINDEN	%UXxx.yy.355	CH3 max./min search function enable/disable	
_xxyy_CH4_FINDEN	%UXxx.yy.356	CH4 max./min search function enable/disable	
_xxyy_CH5_FINDEN	%UXxx.yy.357	CH5 max./min search function enable/disable	
_xxyy_CH6_FINDEN	%UXxx.yy.358	CH6 max./min search function enable/disable	
_xxyy_CH7_FINDEN	%UXxx.yy.359	CH7 max./min search function enable/disable	
_xxyy_CH0_FINDEN	%UXxx.yy.360	CH0 alarm function (process alarm/change rate alarm) enable/disable	
_xxyy_CH1_FINDEN	%UXxx.yy.361	CH1 alarm function (process alarm/change rate alarm) enable/disable	
_xxyy_CH2_FINDEN	%UXxx.yy.362	CH2 alarm function (process alarm/change rate alarm) enable/disable	
_xxyy_CH3_FINDEN	%UXxx.yy.363	CH3 alarm function (process alarm/change rate alarm) enable/disable	
_xxyy_CH4_FINDEN	%UXxx.yy.364	CH4 alarm function (process alarm/change rate alarm) enable/disable	
_xxyy_CH5_FINDEN	%UXxx.yy.365	CH5 alarm function (process alarm/change rate alarm) enable/disable	
_xxyy_CH6_FINDEN	%UXxx.yy.366	CH6 alarm function (process alarm/change rate alarm) enable/disable	
_xxyy_CH7_FINDEN	%UXxx.yy.367	CH7 alarm function (process alarm/change rate alarm) enable/disable	

※ In device assignment, xx means base number module is equipped and yy means slot number module is equipped.

(2) How to use Global variable

There are two methods to register global variable. Automatic registration after I/O parameter setting at project window and batch registration after I/O parameter setting

(a) I/O parameter registration

- Registers the module at I/O parameter

1) Double-click I/O parameter of project window.

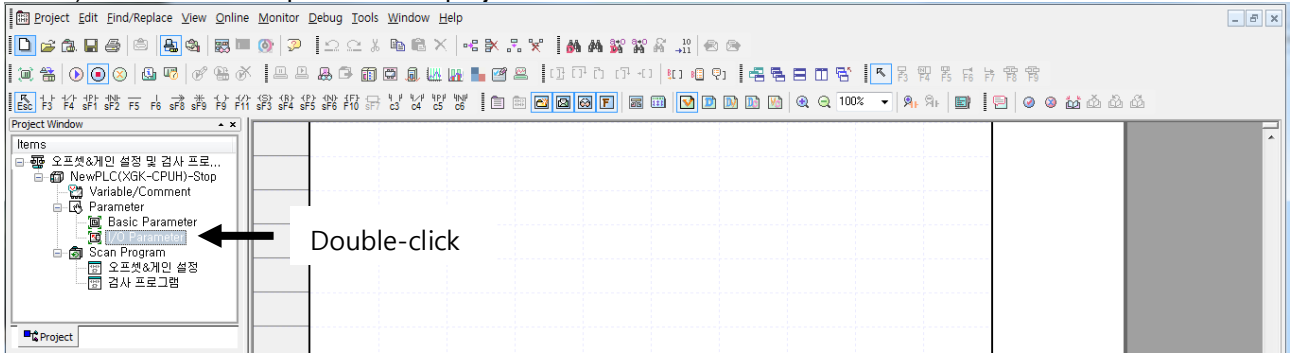

2) Select XGF-RD4A at I/O parameter window.

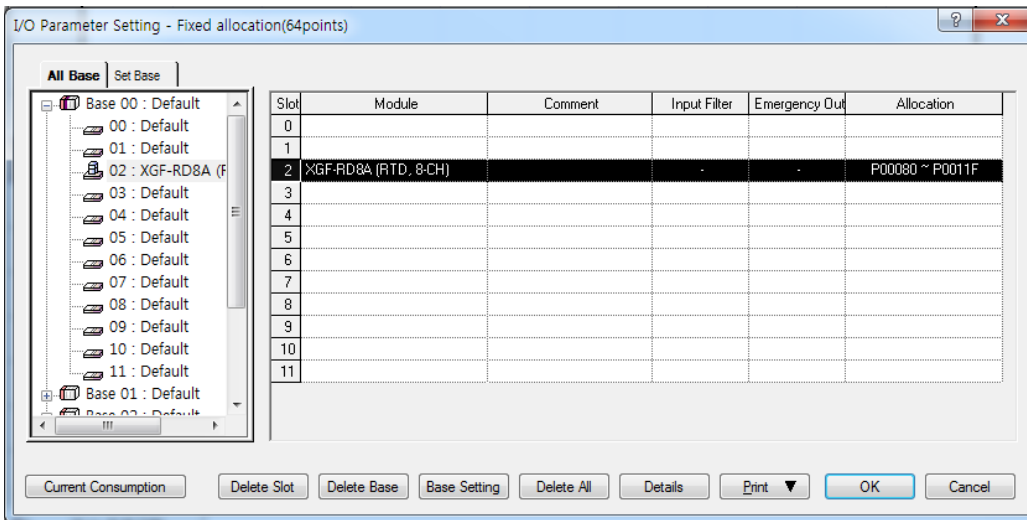

3) Set parameter by pressing [Detail]

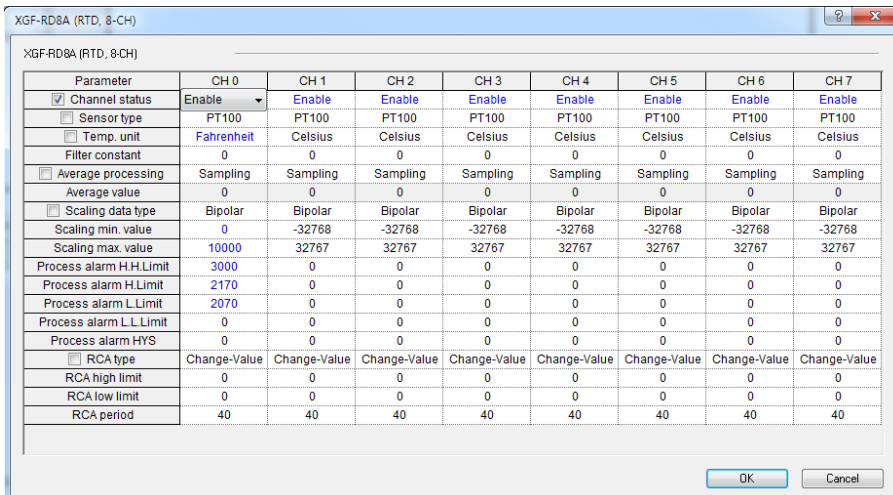

- 4) Select [Yes].
- Registers global variable of module set in I/O parameter

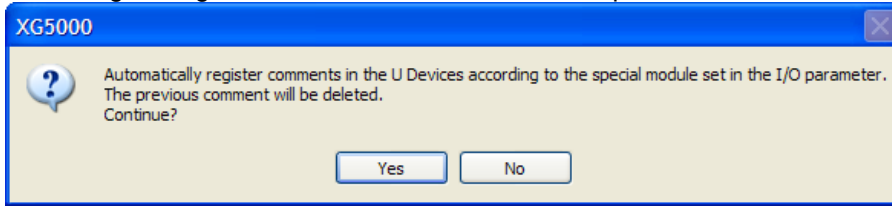

- 5) Checking automatic registration of global variable

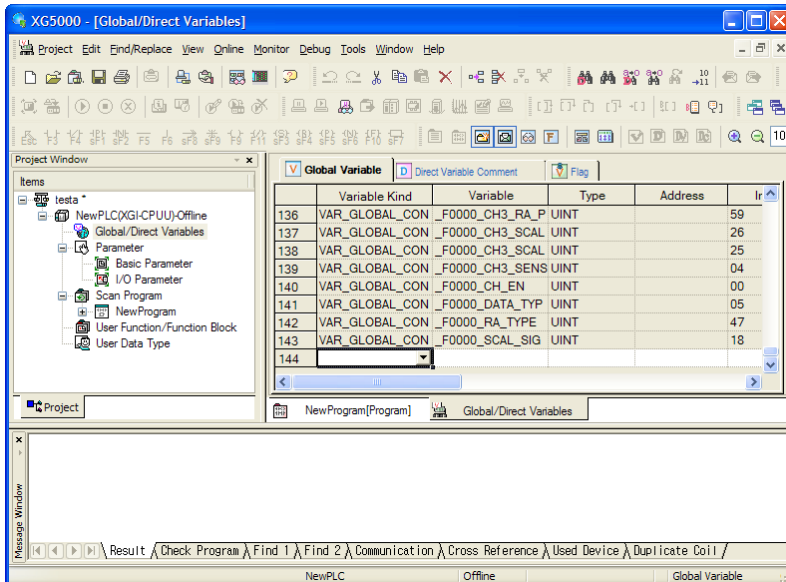
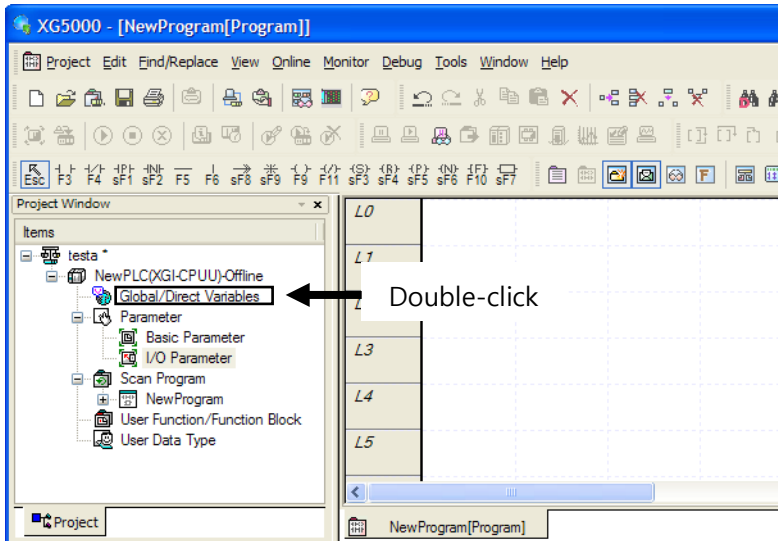

(b) Global variable batch registration

- Registers global variable set in I/O parameter automatically

1) Double-click Global/Direct of project window

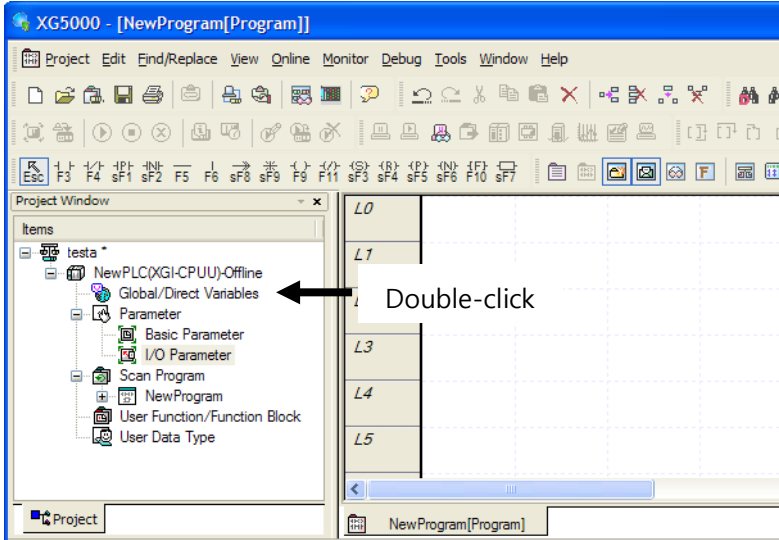

2) Select [Register Special Module Variables] on [Edit].

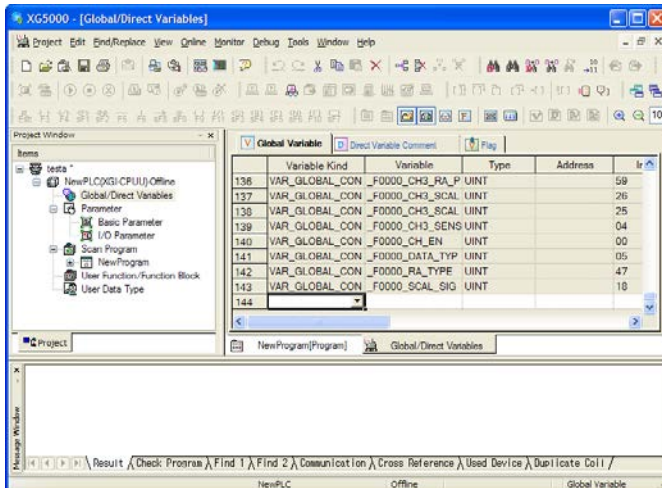
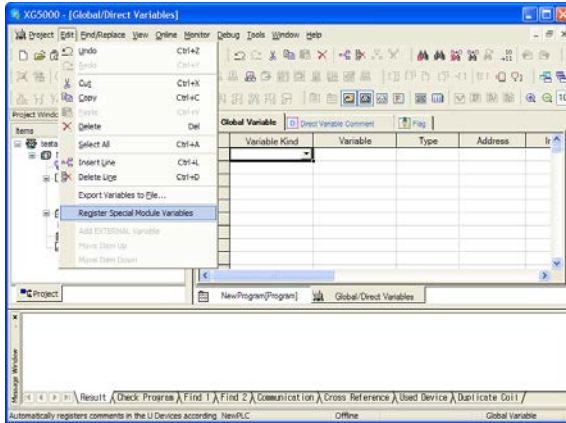

(c) Local variable registration

- Registers variable you want to use among global variables registered at 2) as local variable

1) At the following scan program, double-click local variable of program to use global variable

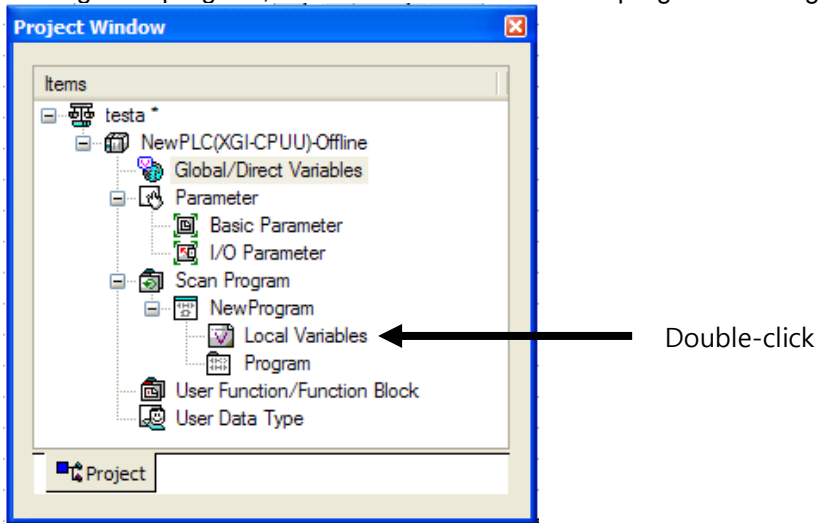

2) Click right button of mouse on the right local variable window and select “Add EXTERNAL variable”

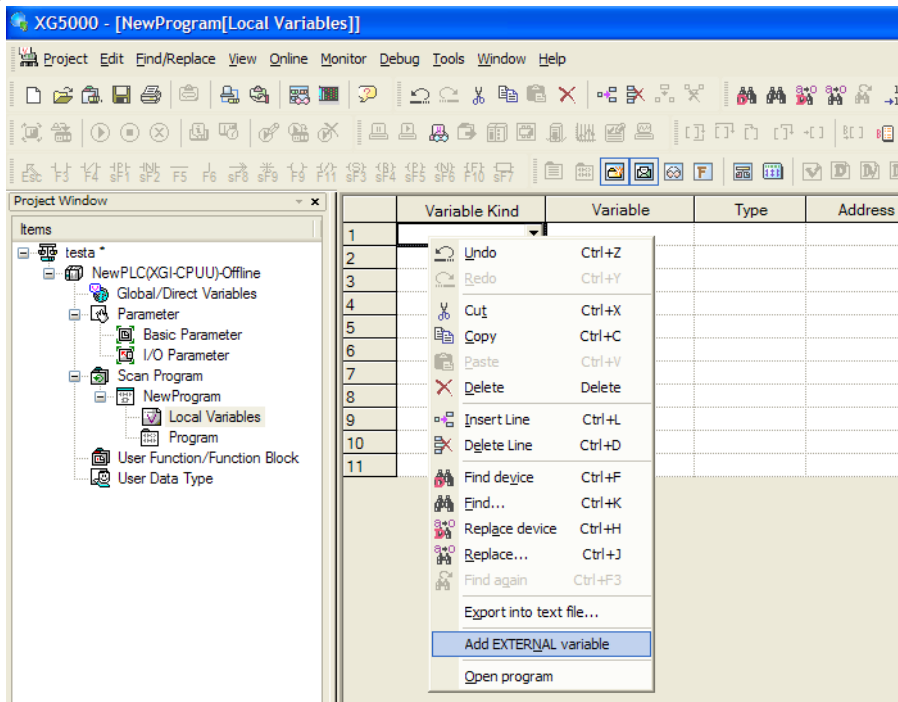

- 3) On the following “Add External Variable” window, select List of Global View as “All” or “Base xx, Slot yy”.
- All

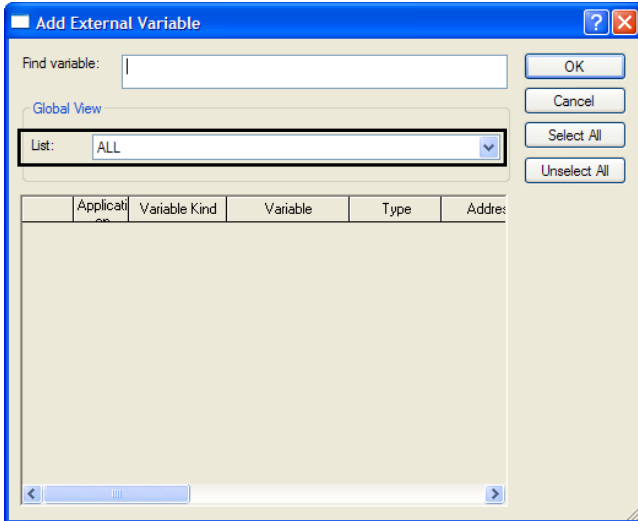

- Base xx, slot yy

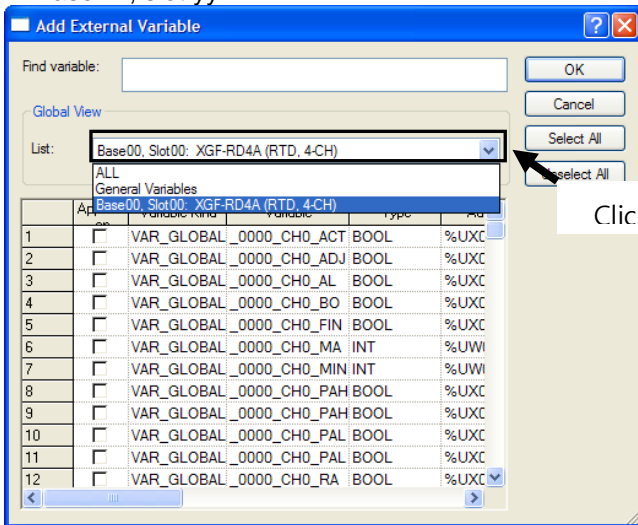

- 4) The following figure is an example when selecting CH 0 Temp. conversion value (_0000_CH0_TEMP) of Base 00, slot 00

	Variable Kind	Variable	Type	Address	Initial Value	Retain	Used	
17	VAR_EXTERNAL	_0000_CH0_MAX	INT	%UW0.0.13		<input type="checkbox"/>	<input type="checkbox"/>	Temp. Measu
18	VAR_EXTERNAL	_0000_CH0_MIN	INT	%UW0.0.12		<input type="checkbox"/>	<input type="checkbox"/>	Temp. Measu
19	VAR_EXTERNAL	_0000_CH0_PAH	BOOL	%UX0.0.34		<input type="checkbox"/>	<input type="checkbox"/>	Temp. Measu
20	VAR_EXTERNAL	_0000_CH0_PAHH	BOOL	%UX0.0.35		<input type="checkbox"/>	<input type="checkbox"/>	Temp. Measu
21	VAR_EXTERNAL	_0000_CH0_PAL	BOOL	%UX0.0.33		<input type="checkbox"/>	<input type="checkbox"/>	Temp. Measu
22	VAR_EXTERNAL	_0000_CH0_PALL	BOOL	%UX0.0.32		<input type="checkbox"/>	<input type="checkbox"/>	Temp. Measu
23	VAR_EXTERNAL	_0000_CH0_RAH	BOOL	%UX0.0.49		<input type="checkbox"/>	<input type="checkbox"/>	Temp. Measu
24	VAR_EXTERNAL	_0000_CH0_RAL	BOOL	%UX0.0.48		<input type="checkbox"/>	<input type="checkbox"/>	Temp. Measu
25	VAR_EXTERNAL	_0000_CH0_SCAL	INT	%UW0.0.8		<input type="checkbox"/>	<input type="checkbox"/>	Temp. Measu
26	VAR_EXTERNAL	_0000_CH0_SETER	BOOL	%UX0.0.24		<input type="checkbox"/>	<input type="checkbox"/>	Temp. Measu
27	VAR_EXTERNAL	_0000_CH0_TEMP	INT	%UW0.0.4		<input type="checkbox"/>	<input type="checkbox"/>	Temp. Measu
28	VAR_EXTERNAL	_0000_CH0_TIME	UDINT	%UD0.0.10		<input type="checkbox"/>	<input type="checkbox"/>	Temp. Measu
29	VAR_EXTERNAL	_0000_CH1_ACT	BOOL	%UX0.0.17		<input type="checkbox"/>	<input type="checkbox"/>	Temp. Measu
30	VAR_EXTERNAL	_0000_CH1_ADJER	BOOL	%UX0.0.1		<input type="checkbox"/>	<input type="checkbox"/>	Temp. Measu
31	VAR_EXTERNAL	_0000_CH1_ALME	BOOL	%UX0.0.469		<input type="checkbox"/>	<input type="checkbox"/>	Temp. Measu

(d) How to use local variable at program

- Here describes how to use added global variable at local program.
- The following is example saving CH0 temp. conversion value in %MW0 area.

1) Double-click variable part in front of IN and open “Select Variable” window by using the following MOVE function

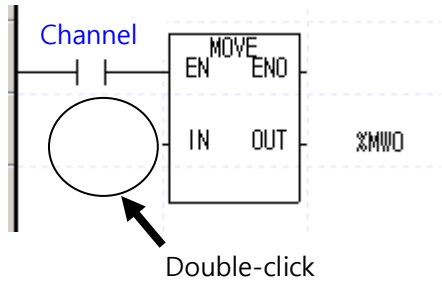

2) On the “Variable List”, select “Global Variable” and on the “List”, select relevant base (Base 0, Slot 0).

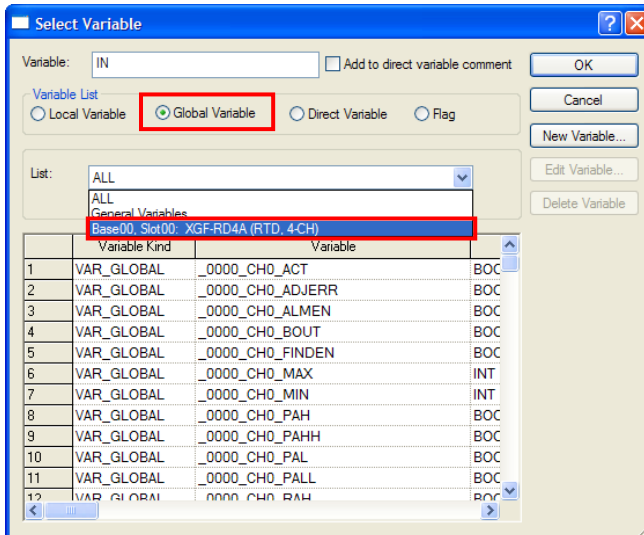

3) Double-click or select _0000_CH0_TEMP relevant to CH0 Temp. conversion value and press [OK].

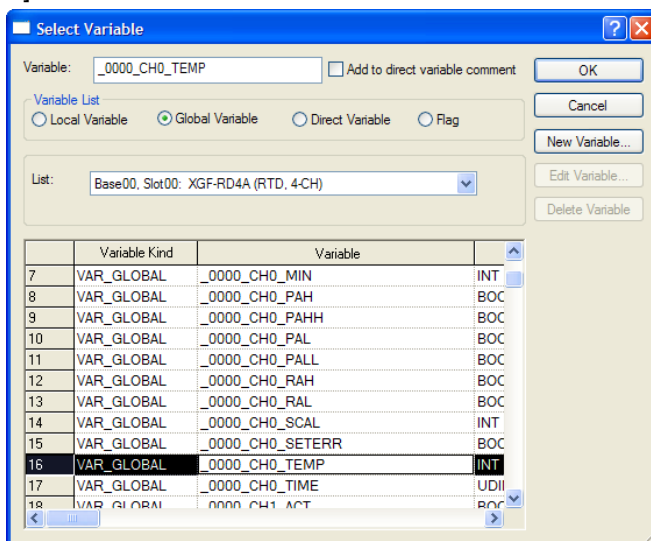

4) The following figure is the result of adding a global variable relevant to CH0 Temp. Conversion value.

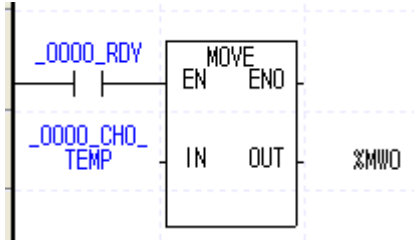

7.2.2 Area using PUTE/GETE Function Block (Parameter Area)

- (1) Area using PUT/GETE_WORD Function Block (Parameter Area)

Operation parameter setting area of D/A conversion module is displayed at Table 7.6

[Table 7. 6] Operation parameter setting area

Global Variable	Contents	Read/Write	Instruction
_Fxyy_CH_EN	Enable channel	Read/Write	PUTE/ GETE_WORD
_Fxyy_CH0_SENSOR	CH 0 sensor type setting	Read/Write	PUTE/ GETE_WORD
_Fxyy_CH1_SENSOR	CH 1 sensor type setting		
_Fxyy_CH2_SENSOR	CH 2 sensor type setting		
_Fxyy_CH3_SENSOR	CH 3 sensor type setting		
_Fxyy_CH4_SENSOR	CH 4 sensor type setting		
_Fxyy_CH5_SENSOR	CH 5 sensor type setting		
_Fxyy_CH6_SENSOR	CH 6 sensor type setting		
_Fxyy_CH7_SENSOR	CH 7 sensor type setting		
_Fxyy_DATA_TYPE	Temp. unit setting	Read/Write	PUTE/ GETE_WORD
_Fxyy_CH0_FILT_CONST	CH0 filter value setting	Read/Write	PUTE/ GETE_WORD
_Fxyy_CH1_FILT_CONST	CH1 filter value setting		
_Fxyy_CH2_FILT_CONST	CH2 filter value setting		
_Fxyy_CH3_FILT_CONST	CH3 filter value setting		
_Fxyy_CH4_FILT_CONST	CH4 filter value setting		
_Fxyy_CH5_FILT_CONST	CH5 filter value setting		
_Fxyy_CH6_FILT_CONST	CH6 filter value setting		
_Fxyy_CH7_FILT_CONST	CH7 filter value setting		
_Fxyy_CH0_AVG_SEL	CH0 average method setting	Read/Write	PUTE/ GETE_WORD
_Fxyy_CH1_AVG_SEL	CH1 average method setting		
_Fxyy_CH2_AVG_SEL	CH2 average method setting		
_Fxyy_CH3_AVG_SEL	CH3 average method setting		
_Fxyy_CH4_AVG_SEL	CH4 average method setting		
_Fxyy_CH5_AVG_SEL	CH5 average method setting		
_Fxyy_CH6_AVG_SEL	CH6 average method setting		
_Fxyy_CH7_AVG_SEL	CH7 average method setting		
_Fxyy_CH0_AVG_VAL	CH0 average value setting	Read/Write	PUTE/ GETE_WORD
_Fxyy_CH1_AVG_VAL	CH1 average value setting		
_Fxyy_CH2_AVG_VAL	CH2 average value setting		
_Fxyy_CH3_AVG_VAL	CH3 average value setting		
_Fxyy_CH4_AVG_VAL	CH4 average value setting		
_Fxyy_CH5_AVG_VAL	CH5 average value setting		
_Fxyy_CH6_AVG_VAL	CH6 average value setting		
_Fxyy_CH7_AVG_VAL	CH7 average value setting		

※In device assignment, xx means base number module is equipped and yy means slot number module is equipped.

[Table 7. 6] Operation parameter setting area

Global Variable	Contents	Read/Write	Instruction
_Fxyy_SCAL_SIGN	Scaling type setting	Read/Write	PUTE/ GETE_WORD
_Fxyy_CH0_SCAL_MIN	CH0 scaling min. value setting	Read/Write	PUTE/ GETE_WORD
_Fxyy_CH0_SCAL_MAX	CH0 scaling max. value setting		
_Fxyy_CH1_SCAL_MIN	CH1 scaling min. value setting		
_Fxyy_CH1_SCAL_MAX	CH1 scaling max. value setting		
_Fxyy_CH2_SCAL_MIN	CH2 scaling min. value setting		
_Fxyy_CH2_SCAL_MAX	CH2 scaling max. value setting		
_Fxyy_CH3_SCAL_MIN	CH3 scaling min. value setting		
_Fxyy_CH3_SCAL_MAX	CH3 scaling max. value setting		
_Fxyy_CH4_SCAL_MIN	CH4 scaling min. value setting		
_Fxyy_CH4_SCAL_MAX	CH4 scaling max. value setting		
_Fxyy_CH5_SCAL_MIN	CH5 scaling min. value setting		
_Fxyy_CH5_SCAL_MAX	CH5 scaling max. value setting		
_Fxyy_CH6_SCAL_MIN	CH6 scaling min. value setting		
_Fxyy_CH6_SCAL_MAX	CH6 scaling max. value setting		
_Fxyy_CH7_SCAL_MIN	CH7 scaling min. value setting	Read/Write	PUTE/ GETE_WORD
_Fxyy_CH7_SCAL_MAX	CH7 scaling max. value setting		
_Fxyy_CH0_PAHH_VAL	CH0 process alarm high-high limit setting		
_Fxyy_CH0_PAH_VAL	CH0 process alarm high limit setting		
_Fxyy_CH0_PAL_VAL	CH0 process alarm low limit setting		
_Fxyy_CH0_PALL_VAL	CH0 process alarm low-low limit setting		
_Fxyy_CH1_PAHH_VAL	CH1 process alarm high-high limit setting		
_Fxyy_CH1_PAH_VAL	CH1 process alarm high limit setting		
_Fxyy_CH1_PAL_VAL	CH1 process alarm low limit setting		
_Fxyy_CH1_PALL_VAL	CH1 process alarm low-low limit setting		
_Fxyy_CH2_PAHH_VAL	CH2 process alarm high-high limit setting		
_Fxyy_CH2_PAH_VAL	CH2 process alarm high limit setting		
_Fxyy_CH2_PAL_VAL	CH2 process alarm low limit setting		
_Fxyy_CH2_PALL_VAL	CH2 process alarm low-low limit setting		
_Fxyy_CH3_PAHH_VAL	CH3 process alarm high-high limit setting		
_Fxyy_CH3_PAH_VAL	CH3 process alarm high limit setting		
_Fxyy_CH3_PAL_VAL	CH3 process alarm low limit setting		
_Fxyy_CH3_PALL_VAL	CH3 process alarm low-low limit setting		
_Fxyy_CH4_PAHH_VAL	CH4 process alarm high-high limit setting		
_Fxyy_CH4_PAH_VAL	CH4 process alarm high limit setting		
_Fxyy_CH4_PAL_VAL	CH4 process alarm low limit setting		
_Fxyy_CH4_PALL_VAL	CH4 process alarm low-low limit setting		
_Fxyy_CH5_PAHH_VAL	CH5 process alarm high-high limit setting		
_Fxyy_CH5_PAH_VAL	CH5 process alarm high limit setting		
_Fxyy_CH5_PAL_VAL	CH5 process alarm low limit setting		
_Fxyy_CH5_PALL_VAL	CH5 process alarm low-low limit setting		

Global Variable	Contents	Read/Write	Instruction
_Fxyy_CH6_PAHH_VAL	CH6 process alarm high-high limit setting	Read/Write	PUTE/ GETE_WORD
_Fxyy_CH6_PAH_VAL	CH6 process alarm high limit setting		
_Fxyy_CH6_PAL_VAL	CH6 process alarm low limit setting		
_Fxyy_CH6_PALL_VAL	CH6 process alarm low-low limit setting		
_Fxyy_CH7_PAHH_VAL	CH7 process alarm high-high limit setting		
_Fxyy_CH7_PAH_VAL	CH7 process alarm high limit setting		
_Fxyy_CH7_PAL_VAL	CH7 process alarm low limit setting		
_Fxyy_CH7_PALL_VAL	CH7 process alarm low-low limit setting		
_Fxyy_CH0_PA_HYS	CH0 process alarm hysteresis setting	Read/Write	PUTE/ GETE_WORD
_Fxyy_CH1_PA_HYS	CH1 process alarm hysteresis setting		
_Fxyy_CH2_PA_HYS	CH2 process alarm hysteresis setting		
_Fxyy_CH3_PA_HYS	CH3 process alarm hysteresis setting		
_Fxyy_CH4_PA_HYS	CH4 process alarm hysteresis setting		
_Fxyy_CH5_PA_HYS	CH5 process alarm hysteresis setting		
_Fxyy_CH6_PA_HYS	CH6 process alarm hysteresis setting		
_Fxyy_CH7_PA_HYS	CH7 process alarm hysteresis setting		
_Fxyy_RA_TYPE	Setting type of change rate alarm	Read/Write	PUTE/ GETE_WORD
_Fxyy_CH0_RAH_VAL	CH0 change rate alarm high limit setting	Read/Write	PUTE/ GETE_WORD
_Fxyy_CH0_RAL_VAL	CH0 change rate alarm low limit setting	Read/Write	PUTE/ GETE_WORD
_Fxyy_CH1_RAH_VAL	CH1 change rate alarm high limit setting		
_Fxyy_CH1_RAL_VAL	CH1 change rate alarm low limit setting		
_Fxyy_CH2_RAH_VAL	CH2 change rate alarm high limit setting		
_Fxyy_CH2_RAL_VAL	CH2 change rate alarm low limit setting		
_Fxyy_CH3_RAH_VAL	CH3 change rate alarm high limit setting		
_Fxyy_CH3_RAL_VAL	CH3 change rate alarm low limit setting		
_Fxyy_CH4_RAH_VAL	CH4 change rate alarm high limit setting		
_Fxyy_CH4_RAL_VAL	CH4 change rate alarm low limit setting		
_Fxyy_CH5_RAH_VAL	CH5 change rate alarm high limit setting		
_Fxyy_CH5_RAL_VAL	CH5 change rate alarm low limit setting		
_Fxyy_CH6_RAH_VAL	CH6 change rate alarm high limit setting		
_Fxyy_CH6_RAL_VAL	CH6 change rate alarm low limit setting		
_Fxyy_CH7_RAH_VAL	CH7 change rate alarm high limit setting		
_Fxyy_CH7_RAL_VAL	CH7 change rate alarm low limit setting		
_Fxyy_CH0_RA_PERIOD	CH0 change rate alarm detection period setting	Read/Write	PUTE/ GETE_WORD
_Fxyy_CH1_RA_PERIOD	CH1 change rate alarm detection period setting		
_Fxyy_CH2_RA_PERIOD	CH2 change rate alarm detection period setting		
_Fxyy_CH3_RA_PERIOD	CH3 change rate alarm detection period setting		
_Fxyy_CH4_RA_PERIOD	CH4 change rate alarm detection period setting		
_Fxyy_CH5_RA_PERIOD	CH5 change rate alarm detection period setting		
_Fxyy_CH6_RA_PERIOD	CH6 change rate alarm detection period setting		
_Fxyy_CH6_RA_PERIOD	CH7 change rate alarm detection period setting		

(2) Other data monitor area (Using GET/GETP)

Global Variable	Contents	Read/Write	Instruction
_Fxyy_CH0_ERR_CODE	CH0 setting error information (flag)	Read	GETE_WORD
_Fxyy_CH1_ERR_CODE	CH1 setting error information (flag)		
_Fxyy_CH2_ERR_CODE	CH2 setting error information (flag)		
_Fxyy_CH3_ERR_CODE	CH3 setting error information (flag)		
_Fxyy_CH4_ERR_CODE	CH4 setting error information (flag)		
_Fxyy_CH5_ERR_CODE	CH5 setting error information (flag)		
_Fxyy_CH6_ERR_CODE	CH6 setting error information (flag)		
_Fxyy_CH7_ERR_CODE	CH7 setting error information (flag)		
_Fxyy_CH0_RAVL	CH0 input change value (change rate alarm function data)	Read	GETE_WORD
_Fxyy_CH1_RAVL	CH1 input change value (change rate alarm function data)		
_Fxyy_CH2_RAVL	CH2 input change value (change rate alarm function data)		
_Fxyy_CH3_RAVL	CH3 input change value (change rate alarm function data)		
_Fxyy_CH4_RAVL	CH4 input change value (change rate alarm function data)		
_Fxyy_CH5_RAVL	CH5 input change value (change rate alarm function data)		
_Fxyy_CH6_RAVL	CH6 input change value (change rate alarm function data)		
_Fxyy_CH7_RAVL	CH7 input change value (change rate alarm function data)		
_Fxyy_CH0_BOUT_CODE	CH0 disconnection information (code)	Read	GETE_WORD
_Fxyy_CH1_BOUT_CODE	CH1 disconnection information (code)		
_Fxyy_CH2_BOUT_CODE	CH2 disconnection information (code)		
_Fxyy_CH3_BOUT_CODE	CH3 disconnection information (code)		
_Fxyy_CH4_BOUT_CODE	CH4 disconnection information (code)		
_Fxyy_CH5_BOUT_CODE	CH5 disconnection information (code)		
_Fxyy_CH6_BOUT_CODE	CH6 disconnection information (code)		
_Fxyy_CH7_BOUT_CODE	CH7 disconnection information (code)		

(3) PUTE/GETE instruction

(a) PUTE instruction

PUTE_WORD/_DWORD
Writing data to special module(Access upper word)

Function Block	Description
	<p>INPUT</p> <p>REQ: When it's 1, function is executed BASE : Base location SLOT : Slot location MADDR : Module address (0 to 1023) MASK : Select word location 0: lower word, 1: upper word DATA : Data to save at module (WORD or DWORD type)</p> <p>OUTPUT</p> <p>DONE : If normally executed, 1 is outputted STAT : Error information</p>

■ **Function**

- 1) Write data from the designated special module
- 2) Sort WORD and DWORD depending on the data type, use it.
- 3) Depending on the state in which it is set to MASK, select the location to save the data.
 - 0=> Low word of the address of the module specified in the MADDR
 - 1=> High word of the address of the module specified in the MADDR

(b) ARY_PUT instruction

ARY_PUT_WORD/_DWORD
Writing data to special module

Function Block	Description																																																																																																																																
<table style="width: 100%; border-collapse: collapse;"> <tr> <td style="width: 20%;"></td> <td style="width: 10%; text-align: center; border: 1px solid black;">ARY_PUT_W ORD</td> <td style="width: 10%;"></td> <td style="width: 10%;"></td> <td style="width: 10%;"></td> <td style="width: 10%;"></td> <td style="width: 10%;"></td> <td style="width: 10%;"></td> </tr> <tr> <td>BOOL</td> <td style="text-align: center;">-REQ</td> <td style="text-align: center;">DONE-</td> <td>BOOL</td> <td></td> <td></td> <td></td> <td></td> </tr> <tr> <td>USINT</td> <td style="text-align: center;">-BASE</td> <td style="text-align: center;">STAT-</td> <td>UINT</td> <td></td> <td></td> <td></td> <td></td> </tr> <tr> <td>USINT</td> <td style="text-align: center;">-SLOT</td> <td></td> <td></td> <td></td> <td></td> <td></td> <td></td> </tr> <tr> <td>UINT</td> <td style="text-align: center;">-MADDR</td> <td></td> <td></td> <td></td> <td></td> <td></td> <td></td> </tr> <tr> <td>UINT</td> <td style="text-align: center;">-MASK</td> <td></td> <td></td> <td></td> <td></td> <td></td> <td></td> </tr> <tr> <td>ARRAY[64] OF WORD</td> <td style="text-align: center;">-DATA</td> <td></td> <td></td> <td></td> <td></td> <td></td> <td></td> </tr> <tr> <td>UINT</td> <td style="text-align: center;">-SIZE</td> <td></td> <td></td> <td></td> <td></td> <td></td> <td></td> </tr> </table> <table style="width: 100%; border-collapse: collapse;"> <tr> <td style="width: 20%;"></td> <td style="width: 10%; text-align: center; border: 1px solid black;">ARY_PUT_D WORD</td> <td style="width: 10%;"></td> <td style="width: 10%;"></td> <td style="width: 10%;"></td> <td style="width: 10%;"></td> <td style="width: 10%;"></td> <td style="width: 10%;"></td> </tr> <tr> <td>BOOL</td> <td style="text-align: center;">-REQ</td> <td style="text-align: center;">DONE-</td> <td>BOOL</td> <td></td> <td></td> <td></td> <td></td> </tr> <tr> <td>USINT</td> <td style="text-align: center;">-BASE</td> <td style="text-align: center;">STAT-</td> <td>UINT</td> <td></td> <td></td> <td></td> <td></td> </tr> <tr> <td>USINT</td> <td style="text-align: center;">-SLOT</td> <td></td> <td></td> <td></td> <td></td> <td></td> <td></td> </tr> <tr> <td>UINT</td> <td style="text-align: center;">-MADDR</td> <td></td> <td></td> <td></td> <td></td> <td></td> <td></td> </tr> <tr> <td>UINT</td> <td style="text-align: center;">-MASK</td> <td></td> <td></td> <td></td> <td></td> <td></td> <td></td> </tr> <tr> <td>ARRAY[64] OF DWORD</td> <td style="text-align: center;">-DATA</td> <td></td> <td></td> <td></td> <td></td> <td></td> <td></td> </tr> <tr> <td>UINT</td> <td style="text-align: center;">-SIZE</td> <td></td> <td></td> <td></td> <td></td> <td></td> <td></td> </tr> </table>		ARY_PUT_W ORD							BOOL	-REQ	DONE-	BOOL					USINT	-BASE	STAT-	UINT					USINT	-SLOT							UINT	-MADDR							UINT	-MASK							ARRAY[64] OF WORD	-DATA							UINT	-SIZE								ARY_PUT_D WORD							BOOL	-REQ	DONE-	BOOL					USINT	-BASE	STAT-	UINT					USINT	-SLOT							UINT	-MADDR							UINT	-MASK							ARRAY[64] OF DWORD	-DATA							UINT	-SIZE							<p>INPUT</p> <p>REQ: When it's 1, function is executed BASE : Base location SLOT : Slot location MADDR : Module address (0 to 1023) MASK : Select word location 0: lower word, 1: upper word DATA : Data to save at module (WORD or DWORD type) SIZE : Write data number (WORD type: 1 to 64, DWORD type: 1 to 32)</p> <p>OUTPUT</p> <p>DONE : If normally executed, 1 is outputted STAT : Error information</p>
	ARY_PUT_W ORD																																																																																																																																
BOOL	-REQ	DONE-	BOOL																																																																																																																														
USINT	-BASE	STAT-	UINT																																																																																																																														
USINT	-SLOT																																																																																																																																
UINT	-MADDR																																																																																																																																
UINT	-MASK																																																																																																																																
ARRAY[64] OF WORD	-DATA																																																																																																																																
UINT	-SIZE																																																																																																																																
	ARY_PUT_D WORD																																																																																																																																
BOOL	-REQ	DONE-	BOOL																																																																																																																														
USINT	-BASE	STAT-	UINT																																																																																																																														
USINT	-SLOT																																																																																																																																
UINT	-MADDR																																																																																																																																
UINT	-MASK																																																																																																																																
ARRAY[64] OF DWORD	-DATA																																																																																																																																
UINT	-SIZE																																																																																																																																

Function

- 1) Write data from the designated special module
- 2) Sort WORD and DWORD depending on the data type, use it.
- 3) Depending on the state in which it is set to MASK, select the location to save the data.
 - 0=> Low word of the address of the module specified in the MADDR
 - 1=> High word of the address of the module specified in the MADDR

Notes

- 1) In XGR system, when using PUTE command to the same upper and lower address with one contact, PUTE command runs abnormal, So separate contacts of the same upper and lower address each other.

3) GETE instruction

GETE_WORD/_DWORD
Reading data from special module

Function Block	Description																																								
<table border="1" style="margin-left: auto; margin-right: auto;"> <tr> <td style="text-align: center;">BOOL</td> <td style="text-align: center;">GETE_WORD REQ</td> <td style="text-align: center;">DONE</td> <td style="text-align: center;">BOOL</td> </tr> <tr> <td style="text-align: center;">USINT</td> <td style="text-align: center;">BASE</td> <td style="text-align: center;">STAT</td> <td style="text-align: center;">UINT</td> </tr> <tr> <td style="text-align: center;">USINT</td> <td style="text-align: center;">SLOT</td> <td style="text-align: center;">DATA</td> <td style="text-align: center;">WORD</td> </tr> <tr> <td style="text-align: center;">UINT</td> <td colspan="3" style="text-align: center;">MADDR</td> </tr> <tr> <td style="text-align: center;">UINT</td> <td colspan="3" style="text-align: center;">MASK</td> </tr> </table> <table border="1" style="margin-left: auto; margin-right: auto;"> <tr> <td style="text-align: center;">BOOL</td> <td style="text-align: center;">GETE_DWORD REQ</td> <td style="text-align: center;">DONE</td> <td style="text-align: center;">BOOL</td> </tr> <tr> <td style="text-align: center;">USINT</td> <td style="text-align: center;">BASE</td> <td style="text-align: center;">STAT</td> <td style="text-align: center;">UINT</td> </tr> <tr> <td style="text-align: center;">USINT</td> <td style="text-align: center;">SLOT</td> <td style="text-align: center;">DATA</td> <td style="text-align: center;">DWORD</td> </tr> <tr> <td style="text-align: center;">UINT</td> <td colspan="3" style="text-align: center;">MADDR</td> </tr> <tr> <td style="text-align: center;">UINT</td> <td colspan="3" style="text-align: center;">MASK</td> </tr> </table>	BOOL	GETE_WORD REQ	DONE	BOOL	USINT	BASE	STAT	UINT	USINT	SLOT	DATA	WORD	UINT	MADDR			UINT	MASK			BOOL	GETE_DWORD REQ	DONE	BOOL	USINT	BASE	STAT	UINT	USINT	SLOT	DATA	DWORD	UINT	MADDR			UINT	MASK			<p>INPUT</p> <p>REQ: When it's 1, function is executed BASE : Base location SLOT : Slot location MADDR : Nodule address (0 to 1023) MASK : Select word location 0: lower word, 1: upper word</p> <p>OUTPUT</p> <p>DONE : If normally executed, 1 is outputted STAT : Error information DATA : Data read from module</p>
BOOL	GETE_WORD REQ	DONE	BOOL																																						
USINT	BASE	STAT	UINT																																						
USINT	SLOT	DATA	WORD																																						
UINT	MADDR																																								
UINT	MASK																																								
BOOL	GETE_DWORD REQ	DONE	BOOL																																						
USINT	BASE	STAT	UINT																																						
USINT	SLOT	DATA	DWORD																																						
UINT	MADDR																																								
UINT	MASK																																								

■ **Function**

- 1) Write data from the designated special module
- 2) Sort WORD and DWORD depending on the data type, use it.
- 3) Depending on the state in which it is set to MASK, select the location to save the data.
 - 0=> Low word of the address of the module specified in the MADDR
 - 1=> High word of the address of the module specified in the MADDR

(d) ARY_GETE instruction

ARY_GETE_WORD/_DWORD

Reading data from special module

Function Block	Description																																																		
<table style="width: 100%; border-collapse: collapse;"> <tr> <td style="width: 15%; text-align: right;">BOOL</td> <td style="width: 15%; border: 1px solid black; padding: 2px;">GETE_WORD</td> <td style="width: 15%; text-align: left;">REQ</td> <td style="width: 15%; border: 1px solid black; padding: 2px;">DONE</td> <td style="width: 15%; text-align: left;">BOOL</td> </tr> <tr> <td style="text-align: right;">USINT</td> <td style="border: 1px solid black; padding: 2px;">BASE</td> <td style="border: 1px solid black; padding: 2px;">STAT</td> <td></td> <td style="text-align: left;">UINT</td> </tr> <tr> <td style="text-align: right;">USINT</td> <td style="border: 1px solid black; padding: 2px;">SLOT</td> <td style="border: 1px solid black; padding: 2px;">DATA</td> <td></td> <td style="text-align: left;">WORD</td> </tr> <tr> <td style="text-align: right;">UINT</td> <td style="border: 1px solid black; padding: 2px;">MADDR</td> <td></td> <td></td> <td></td> </tr> <tr> <td style="text-align: right;">UINT</td> <td style="border: 1px solid black; padding: 2px;">MASK</td> <td></td> <td></td> <td></td> </tr> </table> <table style="width: 100%; border-collapse: collapse;"> <tr> <td style="width: 15%; text-align: right;">BOOL</td> <td style="width: 15%; border: 1px solid black; padding: 2px;">GETE_DWORD</td> <td style="width: 15%; text-align: left;">REQ</td> <td style="width: 15%; border: 1px solid black; padding: 2px;">DONE</td> <td style="width: 15%; text-align: left;">BOOL</td> </tr> <tr> <td style="text-align: right;">USINT</td> <td style="border: 1px solid black; padding: 2px;">BASE</td> <td style="border: 1px solid black; padding: 2px;">STAT</td> <td></td> <td style="text-align: left;">UINT</td> </tr> <tr> <td style="text-align: right;">USINT</td> <td style="border: 1px solid black; padding: 2px;">SLOT</td> <td style="border: 1px solid black; padding: 2px;">DATA</td> <td></td> <td style="text-align: left;">DWORD</td> </tr> <tr> <td style="text-align: right;">UINT</td> <td style="border: 1px solid black; padding: 2px;">MADDR</td> <td></td> <td></td> <td></td> </tr> <tr> <td style="text-align: right;">UINT</td> <td style="border: 1px solid black; padding: 2px;">MASK</td> <td></td> <td></td> <td></td> </tr> </table>	BOOL	GETE_WORD	REQ	DONE	BOOL	USINT	BASE	STAT		UINT	USINT	SLOT	DATA		WORD	UINT	MADDR				UINT	MASK				BOOL	GETE_DWORD	REQ	DONE	BOOL	USINT	BASE	STAT		UINT	USINT	SLOT	DATA		DWORD	UINT	MADDR				UINT	MASK				<p>INPUT</p> <p>REQ: When it's 1, function is executed BASE : Base location SLOT : Slot location MADDR : Nodule address (0 to 1023) MASK : Select word location 0: lower word, 1: upper word</p> <p>OUTPUT</p> <p>DONE : If normally executed, 1 is outputted STAT : Error information DATA : Data read from module</p>
BOOL	GETE_WORD	REQ	DONE	BOOL																																															
USINT	BASE	STAT		UINT																																															
USINT	SLOT	DATA		WORD																																															
UINT	MADDR																																																		
UINT	MASK																																																		
BOOL	GETE_DWORD	REQ	DONE	BOOL																																															
USINT	BASE	STAT		UINT																																															
USINT	SLOT	DATA		DWORD																																															
UINT	MADDR																																																		
UINT	MASK																																																		

*ANY: WORD, DWORD, INT, UINT, DINT, UDINT are available among ANY type

■ **Function**

- 1) Write data from the designated special module
- 2) Sort WORD and DWORD depending on the data type, use it.
- 3) Depending on the state in which it is set to MASK, select the location to save the data.
 - 0=> Low word of the address of the module specified in the MADDR
 - 1=> High word of the address of the module specified in the MADDR

(4) Example of PUTE/GETE instruction

(a) Enable channel

- 1) You can enable/disable every channel respectively.
- 2) Disable the unused channel to reduce the conversion period.
- 3) Default is all channels are disabled.
- 4) Enable/Disable of temp. conversion is as follows.

B15	B14	B13	B12	B11	B10	B9	B8	B7	B6	B5	B4	B3	B2	B1	B0
—	—	—	—	—	—	—	—	C	C	C	C	C	C	C	C
								H	H	H	H	H	H	H	H
								7	6	5	4	3	2	1	0

Bit	Description
0	Disabled
1	Enabled

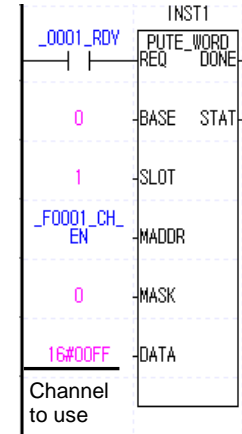
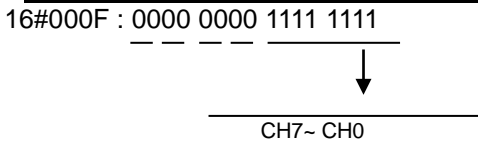

- 5) The values set in B8~B15 are ignored.
- 6) On the right figure, CH0~CH7 of module equipped at slot 1 are enabled.

(b) Sensor type setting

- 1) Sets sensor type about type of input sensor
- 2) If out of set value is inputted, setting error occurs and that is set as "0".

B31	B30	B29	B28	B27	B26	B25	B24	B23	B22	B21	B20	B19	B18	B17	B16
CH 4~7 Sensor type setting															

B15	B14	B13	B12	B11	B10	B9	B8	B7	B6	B5	B4	B3	B2	B1	B0
CH 0~3 Sensor type setting															

Word value	Description
0	PT100
1	JPT100

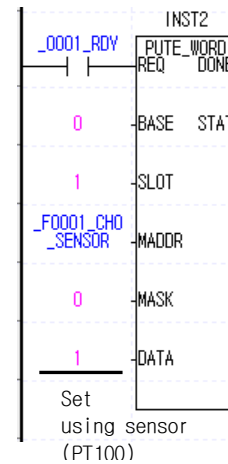

(c) Temperature conversion unit setting

1) Temperature-converted value can be output in °C or °F as specified.

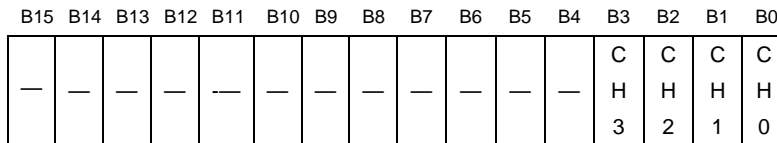
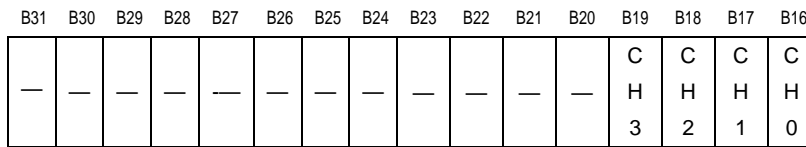

Bit	Description
0	Celsius
1	Fahrenheit

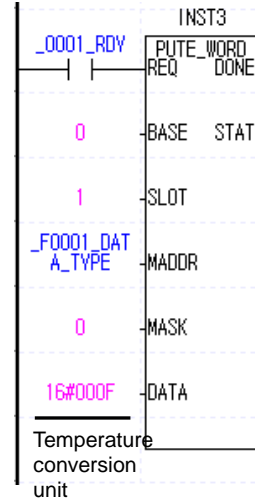
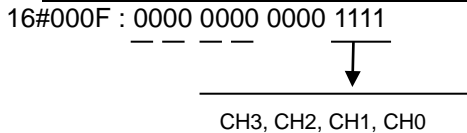

- 2) The values set in B4~B15 and B20~B31 are ignored.
- 3) On the right figure, CH0~CH3 of module equipped at slot 1 are set as Fahrenheit.

(d) Filter value setting

- 1) If filter values set "0", designated channels output temperature conversion value not executing filter value but executing sampling value.
- 2) if filter values set 1 to 319 or more than 64001, filter values set to "0" and module occurs to setting error.

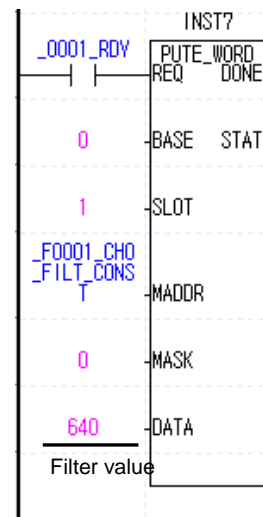
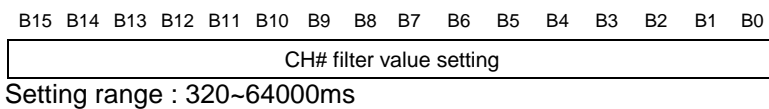

(e) Average method setting

- 1) If average method values set more than 4, average method values set to "0" and module occurs to setting error.
- 2) If input more than 3, it displays setting error and setting value is designated "0".

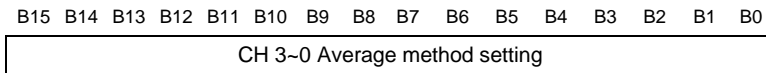
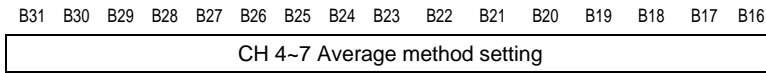

Word	Description
0	Sampling
1	Time averaging
2	Count averaging
3	Moving averaging

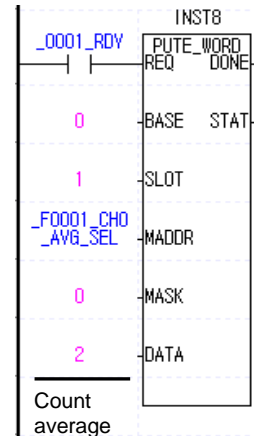

(f) Average value setting

- 1) If averaging method is sampling, this area is ignored.
 - 2) If average value is out of setting range, error occurs and that is set as maximum or minimum value
- Ex) If you select time averaging and set average value as 200, setting error occurs and that is set as 640

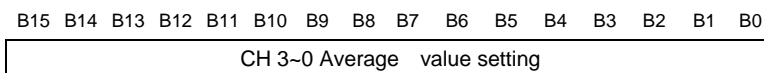
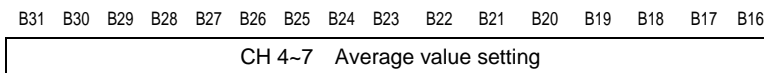

Item	Setting value
Time averaging	640~64000[ms]
Count averaging	2~64000[times]
Moving averaging	2~100[unit]

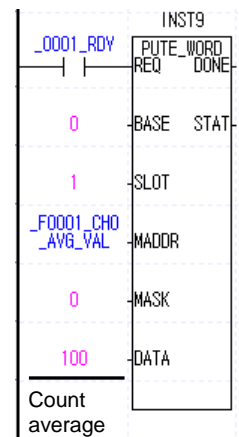

(g) Scale type setting

- 1) If relevant bit is "1", output data range by scaling operation will be "0~65535".
- 2) If relevant bit is "0", output data range by scaling operation will be "-32768~32767"(default)

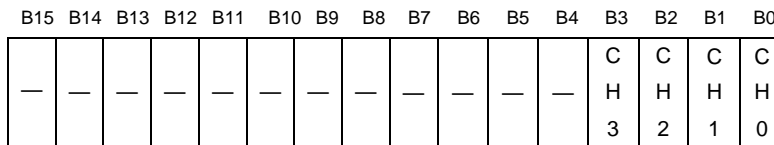
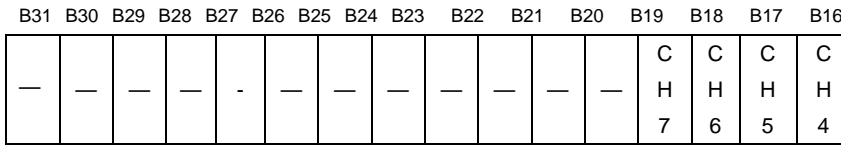

Bit	description
0	Signed scaling range
1	Unsigned scaling range

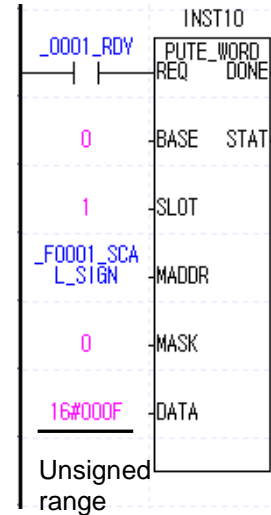
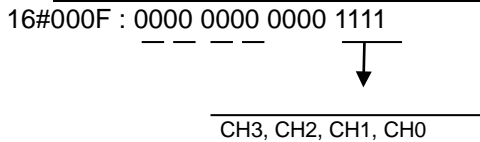

(h) Setting of max/min value of scaling range

- 1) If it is out of range, setting error occurs and it is not changed.

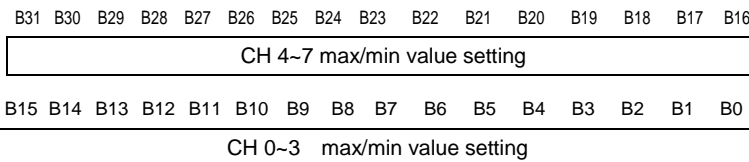

Item	Setting value
Signed type	-32,768 ~ 32,767
Unsigned type	0 ~ 65535

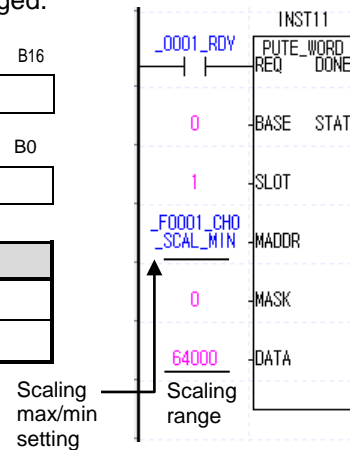

(i) Process alarm boundary value setting

- 1) Setting range can be set according to output temperature type (Celsius/Fahrenheit) and sensor type (Pt100/JPt100) differently.
- 2) If it is out of range, setting error occurs and it is not changed.

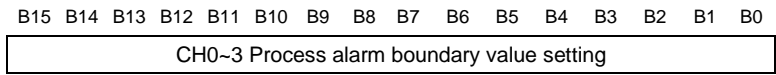
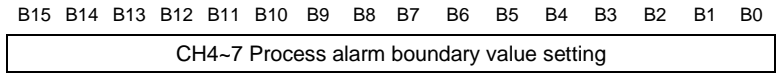

Item		Setting value
PT100	Celsius	-2000 ~ 8500
	Fahrenheit	-3280 ~ 15620
JPT100	Celsius	-2000 ~ 6400
	Fahrenheit	-3280 ~ 11840

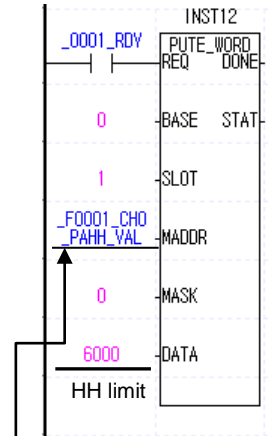

HH limit
H limit
L limit
LL limit

(j) Process alarm hysteresis setting

- 1) If it is out of range, setting error occurs and it is not changed.
- 2) When using process alarm and it meets clear condition of alarm, if is within the hysteresis setting range, the alarm output keeps

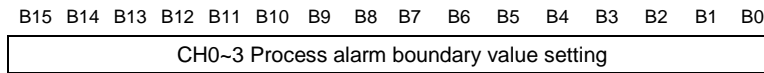
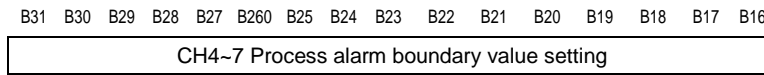

Setting value
0 ~ 1000

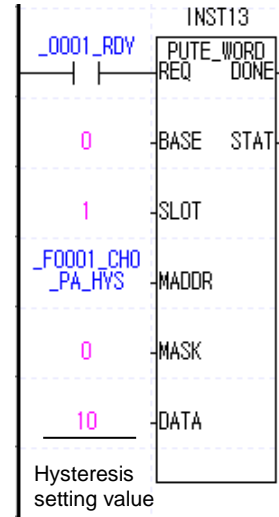

(k) Change rate alarm setting type setting

- 1) Relevant bit is set as "1", change rate alarm is used as standard of alarm output. Change rate means the rate of input range according to sensor type.

Example) change rate in case of PT100

$$\text{Change rate[\%]} = \frac{(\text{Current temp.} - \text{alarm previous temp.}) \times 100}{(8500 - (-2000))}$$

- 2) In case it is set as "0", temp. change value is used as standard of alarm output

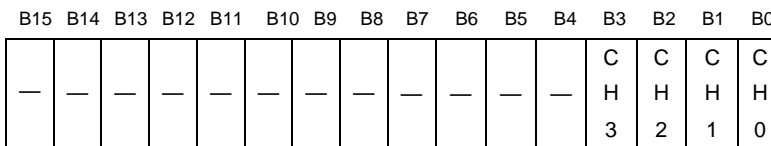
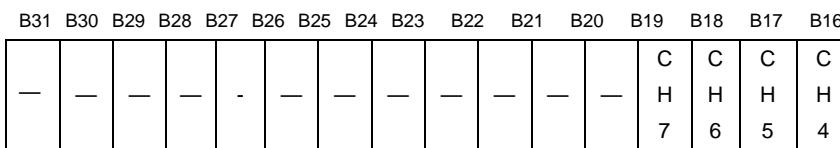

Bit	Description
0	Temp. change value
1	Temp. change rate

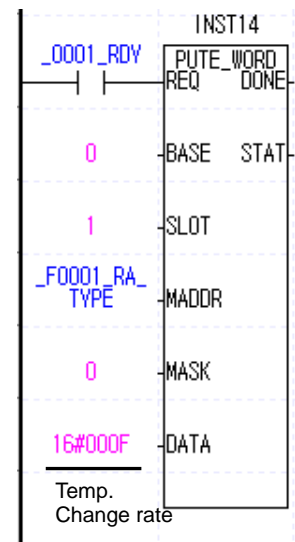
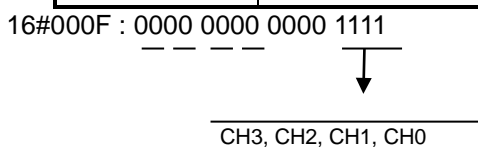

(l) Change rate alarm high limit/low limit boundary value setting

- 1) If it is out of range, setting error occurs and it is set as "0".
- 2) In case of temp. change rate, it becomes percent value indicating first decimal point
- 3) In case alarm setting value type of change rate alarm is temp. change value, unit of this value is temp.

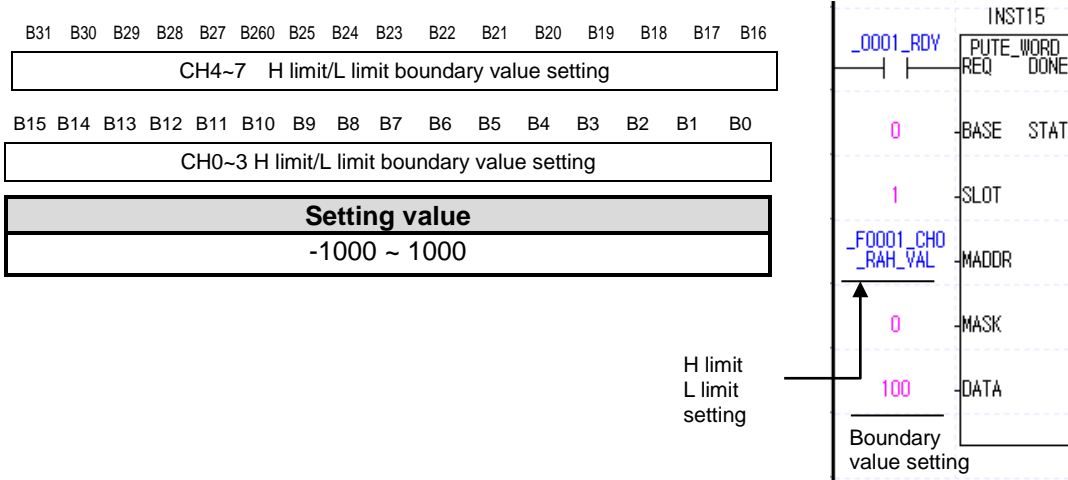

(m) Change rate alarm detection period setting

- 1) Setting period to detecting change rate when using change rate alarm function.
- 2) If it is out of range, setting error occurs and it is set as "40".

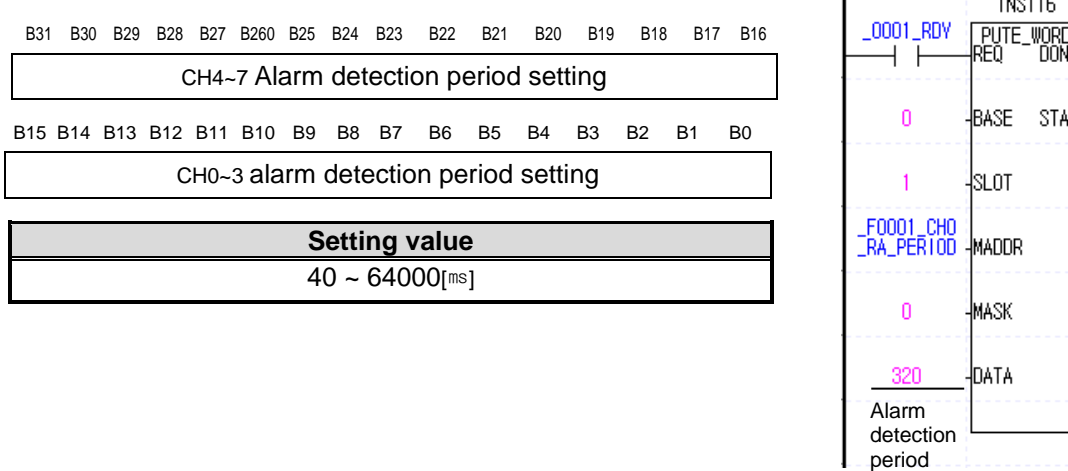

(n) Channel setting error information (flag)

- 1) If it is out of range (in case of setting by program), relevant bit becomes "1"
- 2) Setting error is clear off when you set the value again to be in the range.
- 3) In case of setting error, there is no LEC indication. When bits of Uxy.01.08~Uxy.01.0B are on, check the relevant setting.
- 4) Relevant setting address and error contents for each bit
 - Bit 0: Channel sensor type setting error
 - Bit 1: Channel filter value setting error
 - Bit 2: Channel average type setting error
 - Bit 3: Channel average value setting error
 - Bit 4: Channel scale min. range setting error
 - Bit 5: Channel scale max. range setting error
 - Bit 6: Channel process alarm HH limit setting error
 - Bit 7: Channel process alarm H limit setting error
 - Bit 8: Channel process alarm L limit setting error
 - Bit 9: Channel process alarm LL limit setting error
 - Bit A: Channel process alarm hysteresis setting error
 - Bit B: Channel change rate alarm setting error
 - Bit C: Channel change rate alarm L limit setting error
 - Bit D: Channel change rate alarm detection period setting error

B31	B30	B29	B28	B27	B26	B25	B24	B23	B22	B21	B20	B19	B18	B17	B16
—	—	C	C	C	C	C	C	C	C	C	C	C	C	C	C
		H	H	H	H	H	H	H	H	H	H	H	H	H	H
		4	4	4	4	4	4	4	4	4	4	4	4	4	4

B15	B14	B13	B12	B11	B10	B9	B8	B7	B6	B5	B4	B3	B2	B1	B0
—	—	C	C	C	C	C	C	C	C	C	C	C	C	C	C
		H	H	H	H	H	H	H	H	H	H	H	H	H	H
		0	0	0	0	0	0	0	0	0	0	0	0	0	0

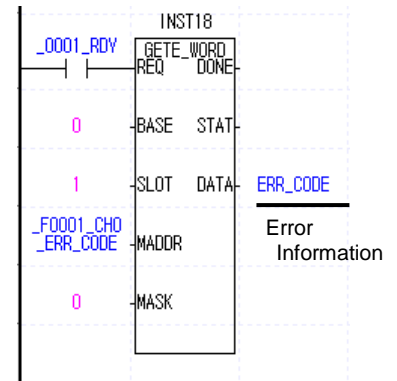

(o) Change rate alarm conversion value output

- 1) During the designated detection period, it outputs changed input (temp. value) or change rate (percentage according to sensor range)

Output range		
Change rate		-1023 ~ 1023
Change value	PT100	-10700 ~ 10700
	JPT	-8600 ~ 8600

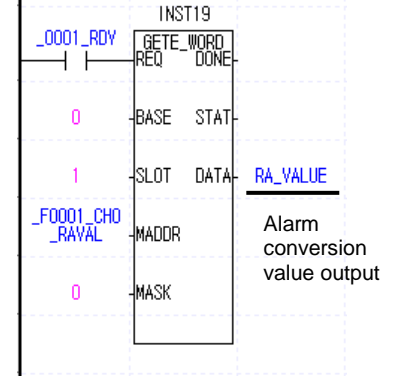

(p) Sensor disconnection information output

- 1) Area outputting disconnection detection information

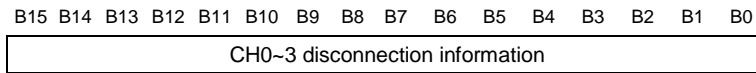
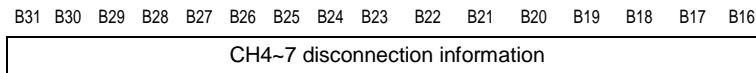

Output range	
0	normal
1	sensor A disconnection
2	sensor B disconnection

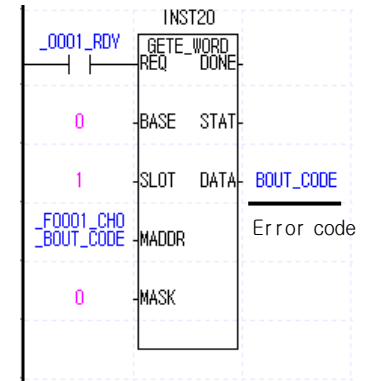

Chapter 8 Programming (For XGI/XGR)

8.1 XGF-RD4A/XGF-RD4S

8.1.1 Basic Program

- Describes about how to set operation condition of internal memory of RTC input module
- RTC input module is equipped at slot 2.
- I/O occupation points of RTC input module is 16 points (flexible type)

System configuration

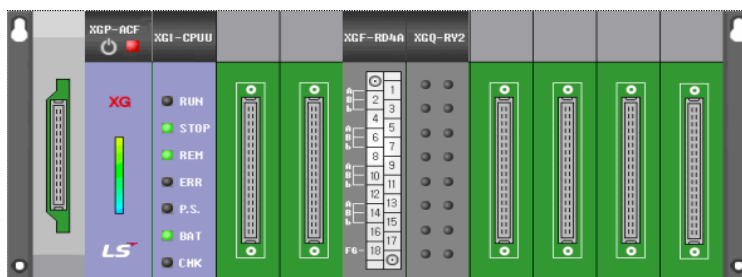

(1) Program example using [I/O parameter]

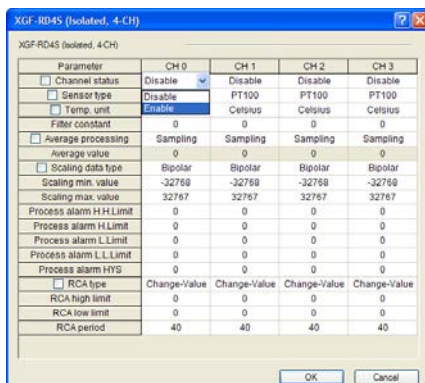
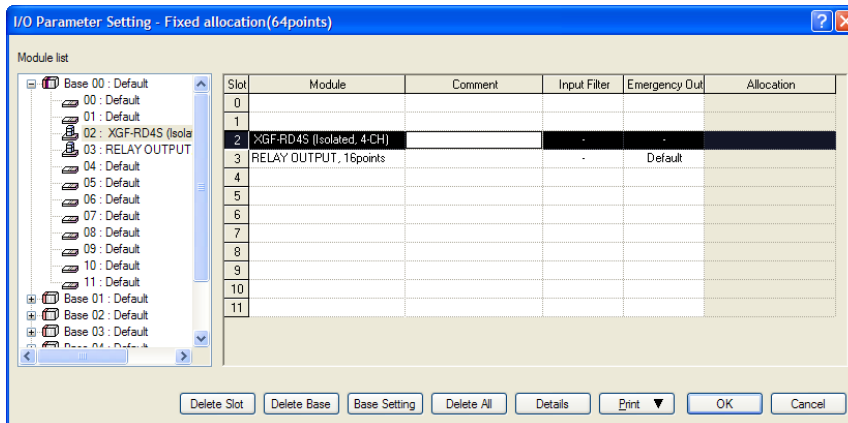

► Register module and after setting the operation parameter, download it to PLC.

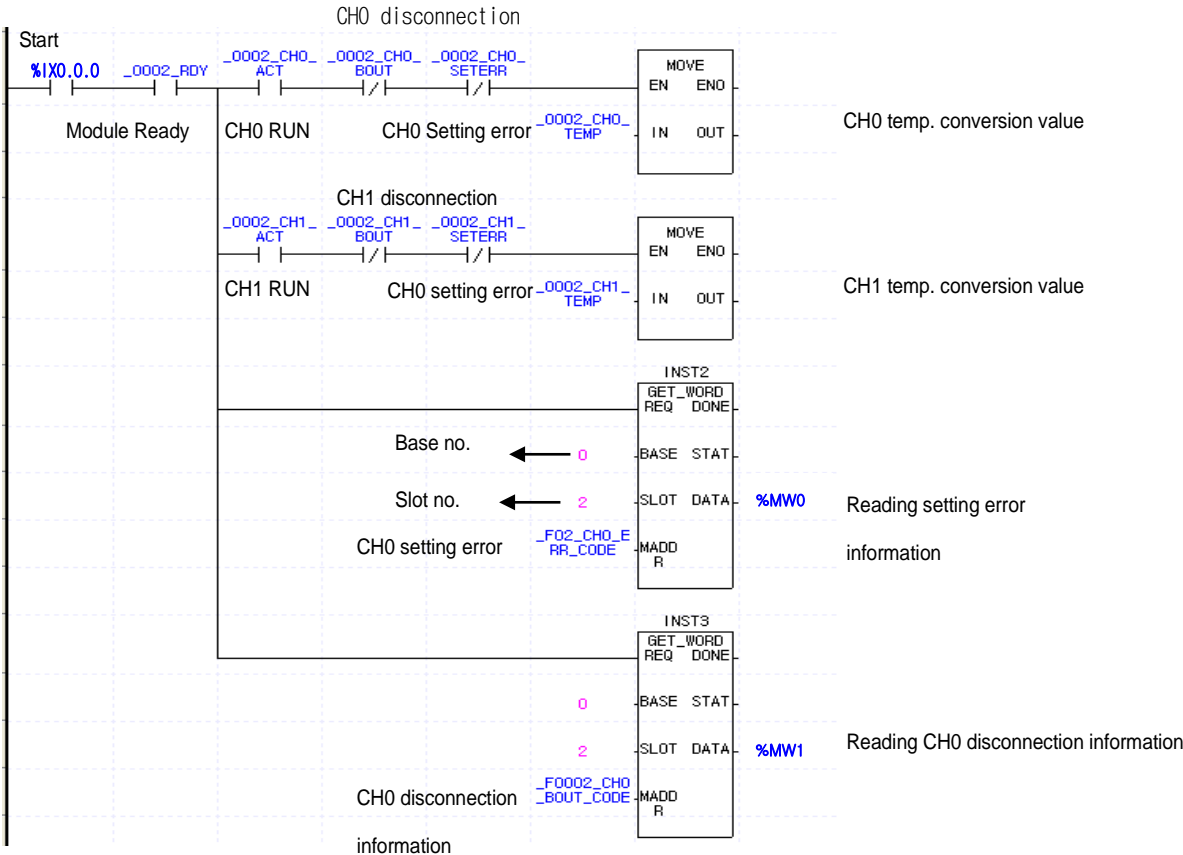

(2) Program example using PUT/GET instruction

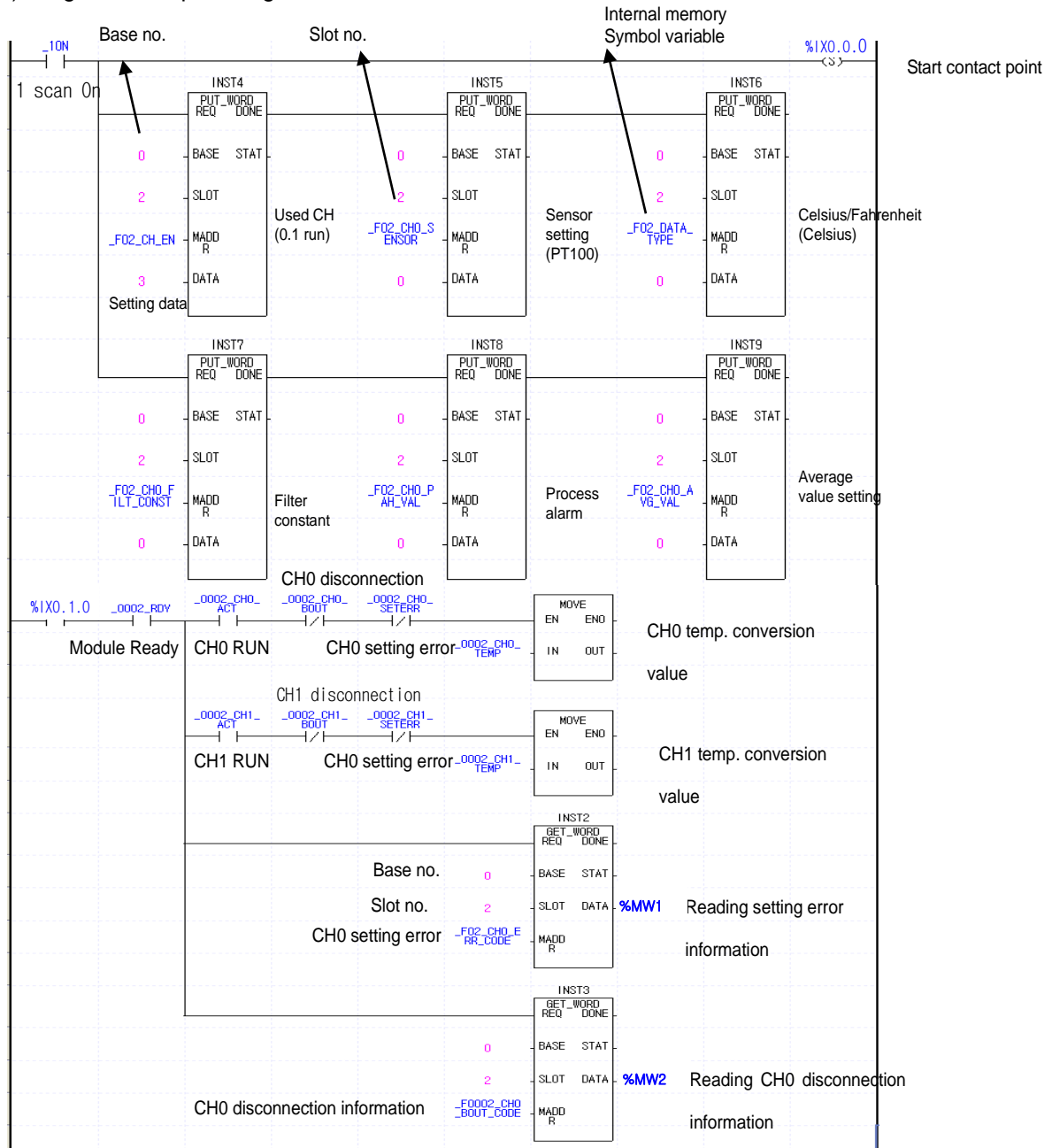

8.1.2 Application Program

(1) Program monitoring Celsius conversion value and scaling operation value

(a) System configuration

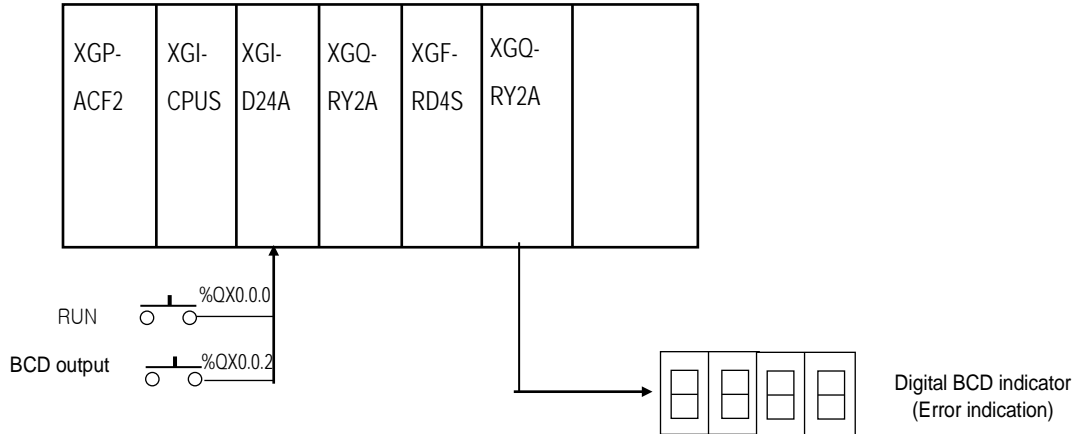

(b) Initial setting contents

No.	Item	Initial setting contents	Value to write at internal memory
1	Used CH	CH 0, CH 1	'h003' or '3'
2	Sensor type	PT100(0)	'h0000' or '0'
3	Temp. unit	Celsius (0)	'h0000' or '0'
4	Filter value	0	'h00C8' or '200'
5	Scaling type	0	'h0000' or '0'
6	Scaling range max./min.	Max.: 32767 Min.: -32768	Max.: 'h2710' or '10000' Min.: 'h0000' or '0'

(c) Program description

1) Outputs temp. conversion value of CH 0, 1 to D0, D1 and scaling operation value to D10, D11 by operation start contact point (%QX0.0.0). At this time, scaling operation value means value converting temp. conversion value -200 ~ 850 °C to 0 ~ 10000.

Operation expression is as follows

- Scaling operation:
$$Y = \frac{10000}{10500}(X + 2000)$$

Y : Scaling operation value, X : Temp.

(But, temp. value is 10 times of real temperature value)

2) Filter value of CH 0, 1 is set as "200" to change the temperature change gradually about rapid temperature change.

3) Outputs setting error information and disconnection information to variable M0, M10. Outputs setting error information to %QW0.3.0 with BCD by P00002.

(d) Program

1) Program example using [I/O Parameter]

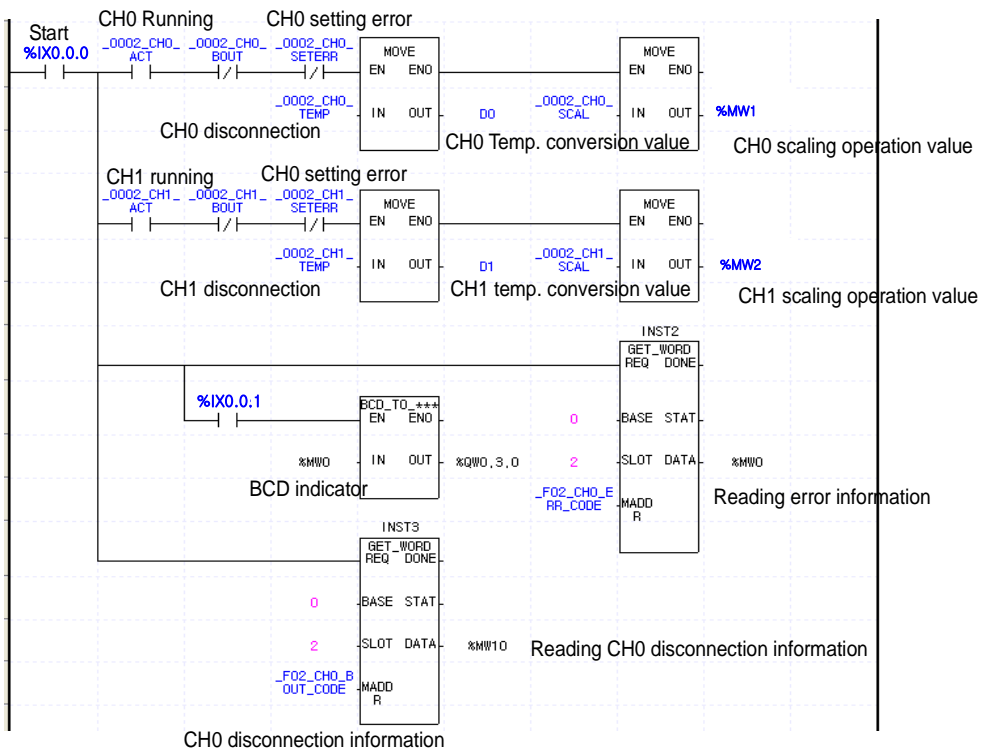
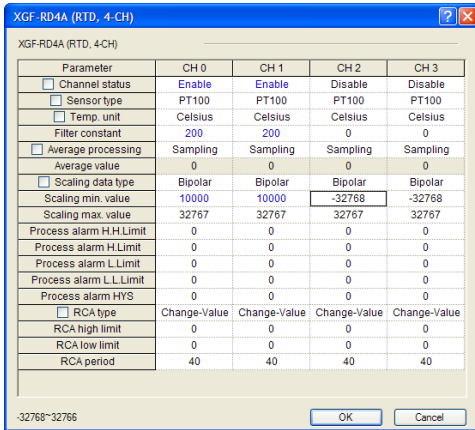
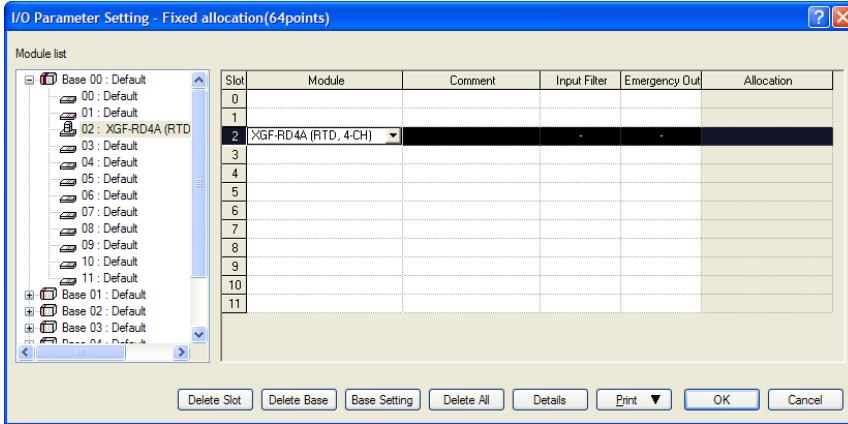

2) Program example using PUT/GET_WORD instruction

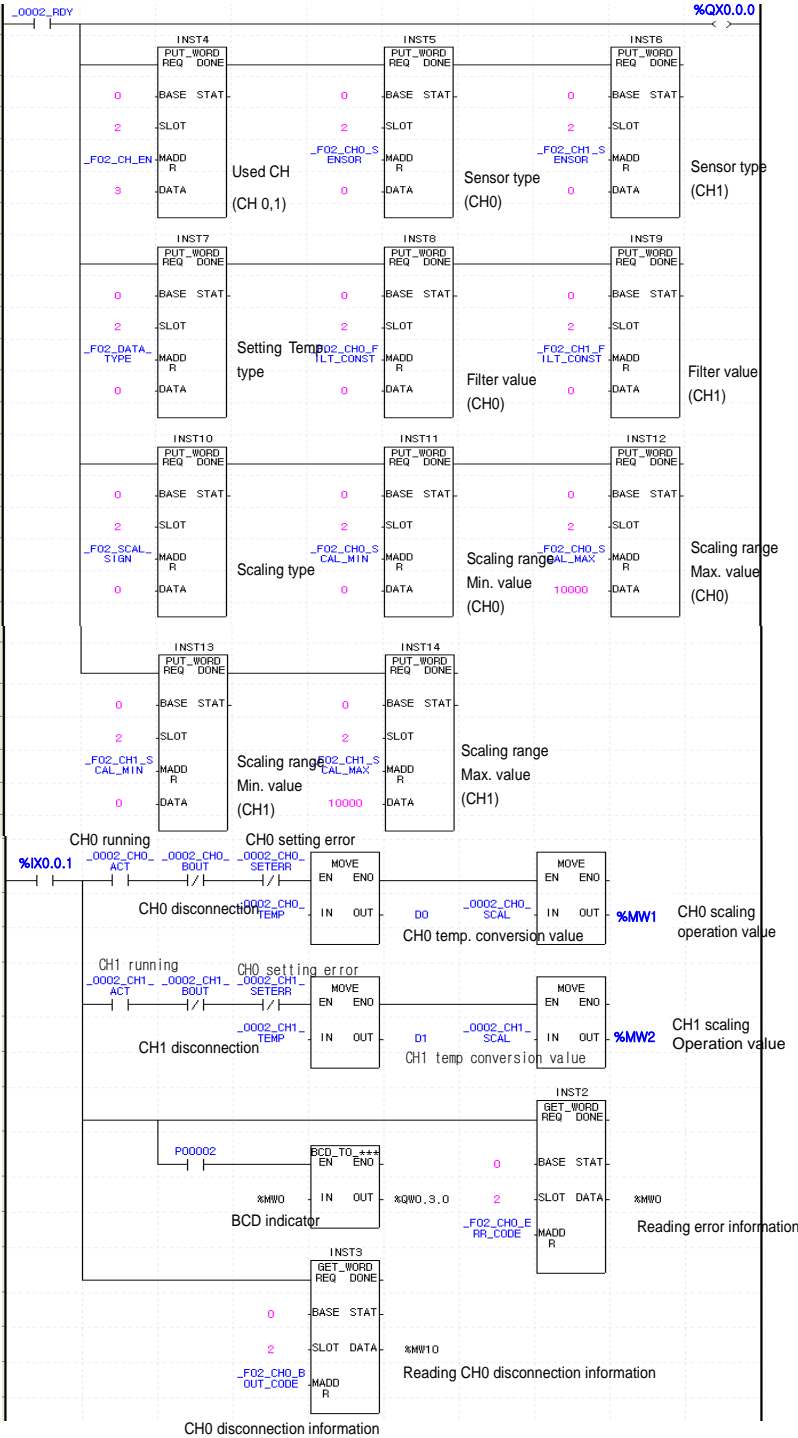

8.2 XGF-RD8A

8.2.1 Basic Program

- Describes about how to set operation condition of internal memory of RTC input module
- RTC input module is equipped at slot 2.
- I/O occupation points of RTC input module is 16 points (flexible type)

System configuration

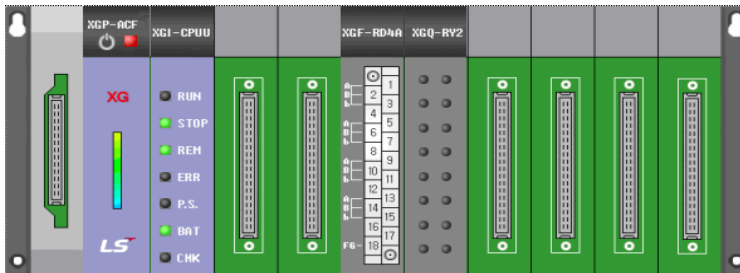

(1) Program example using [I/O parameter]

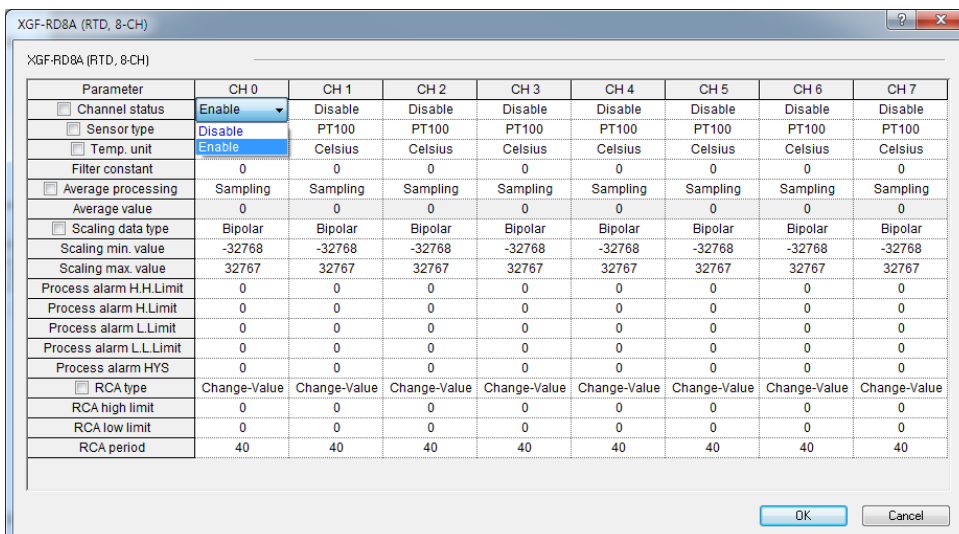
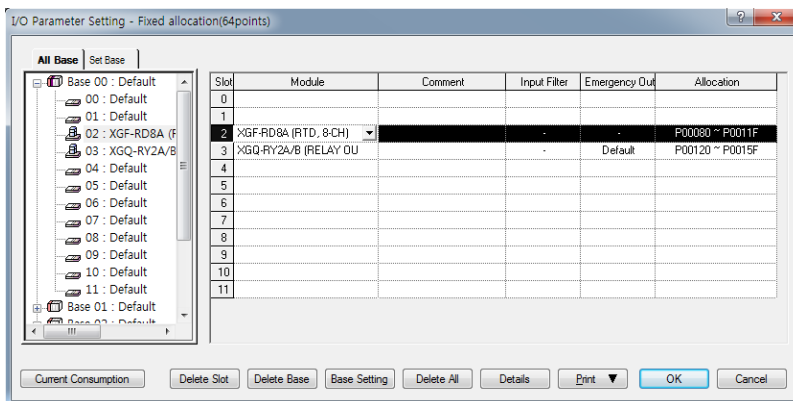

▶ Register module and after setting the operation parameter, download it to PLC.

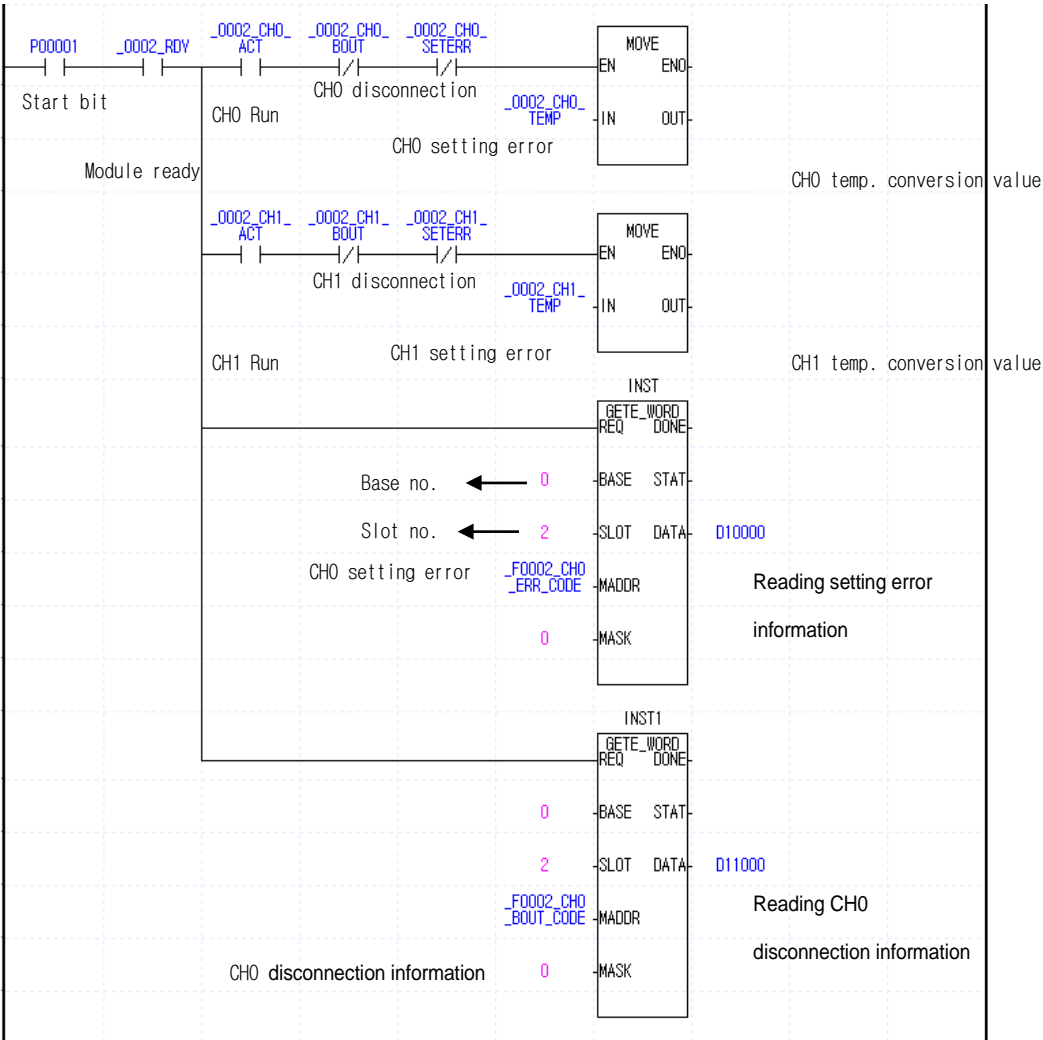

(2) Program example using PUT/GET instruction

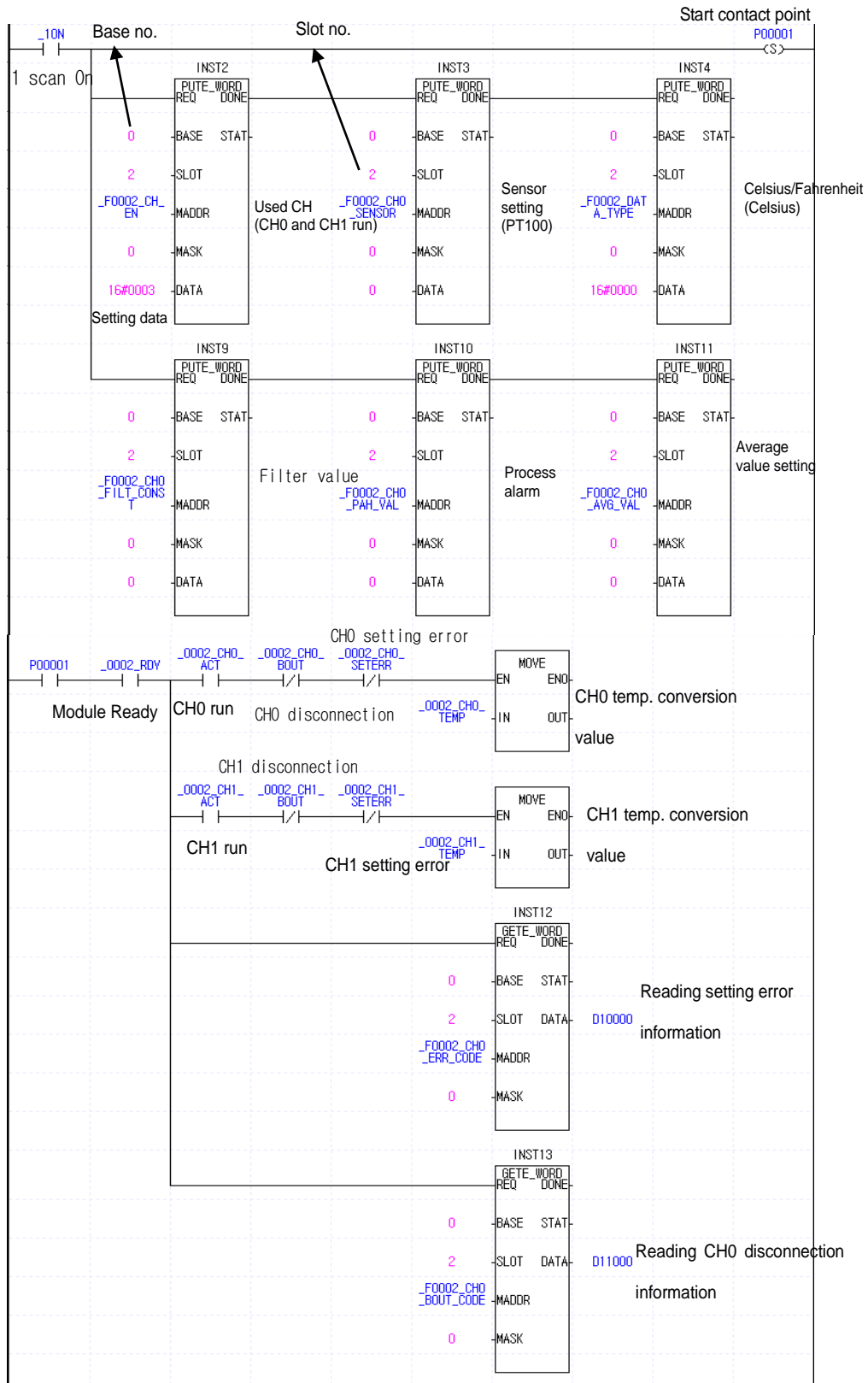

8.2.2 Application Program

(1) Program monitoring Celsius conversion value and scaling operation value

(a) System configuration

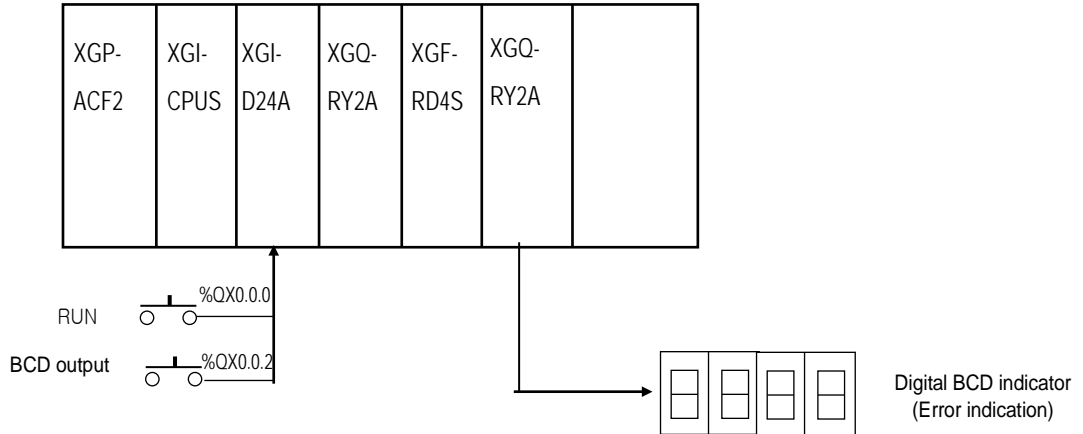

(b) Initial setting contents

No.	Item	Initial setting contents	Value to write at internal memory
1	Used CH	CH 0, CH 1	'h003' or '3'
2	Sensor type	PT100(0)	'h0000' or '0'
3	Temp. unit	Celsius (0)	'h0000' or '0'
4	Filter value	0	'h00C8' or '200'
5	Scaling type	0	'h0000' or '0'
6	Scaling range max./min.	Max.: 32767 Min.: -32768	Max.: 'h2710' or '10000' Min.: 'h0000' or '0'

(c) Program description

- 1) Outputs temp. conversion value of CH 0, 1 to D0, D1 and scaling operation value to D10, D11 by operation start contact point (%QX0.0.0). At this time, scaling operation value means value converting temp. conversion value -200 ~ 850°C 세 0 ~ 10000.

Operation expression is as follows

$$\bullet \text{ Scaling operation: } Y = \frac{10000}{10500} (X + 2000)$$

Y : Scaling operation value, X : Temp.

(But, temp. value is 10 times of real temperature value)

- 2) Filter value of CH 0, 1 is set as "200" to change the temperature change gradually about rapid temperature change.
- 3) Outputs setting error information and disconnection information to variable M0, M10. Outputs setting error information to %QW0.3.0 with BCD by P00002.

(d) Program

1) Program example using [I/O Parameter]

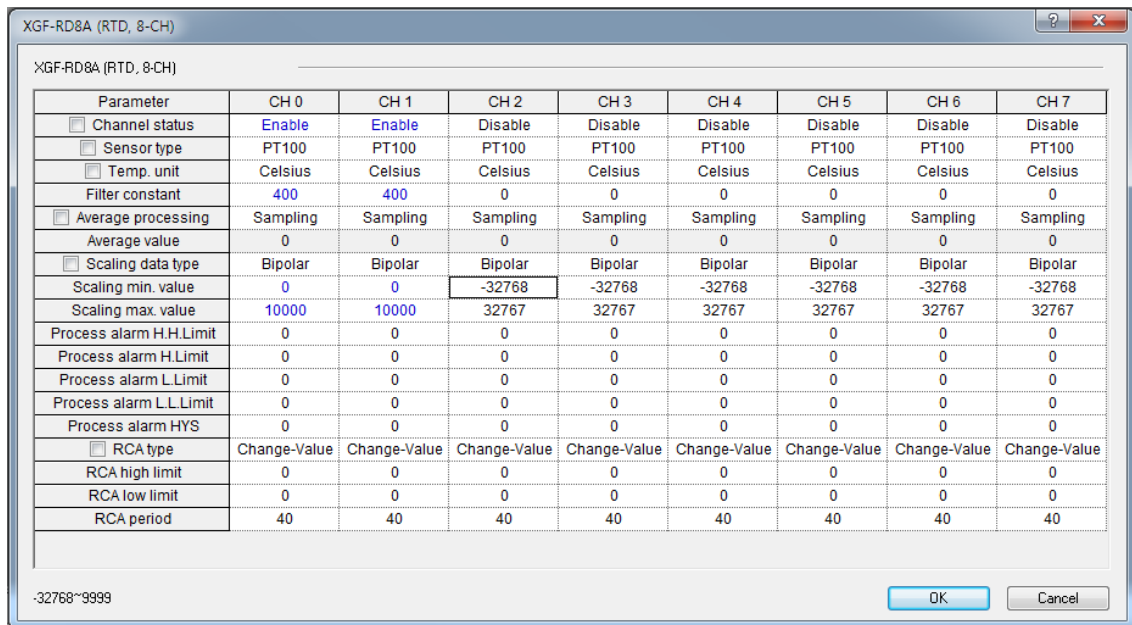
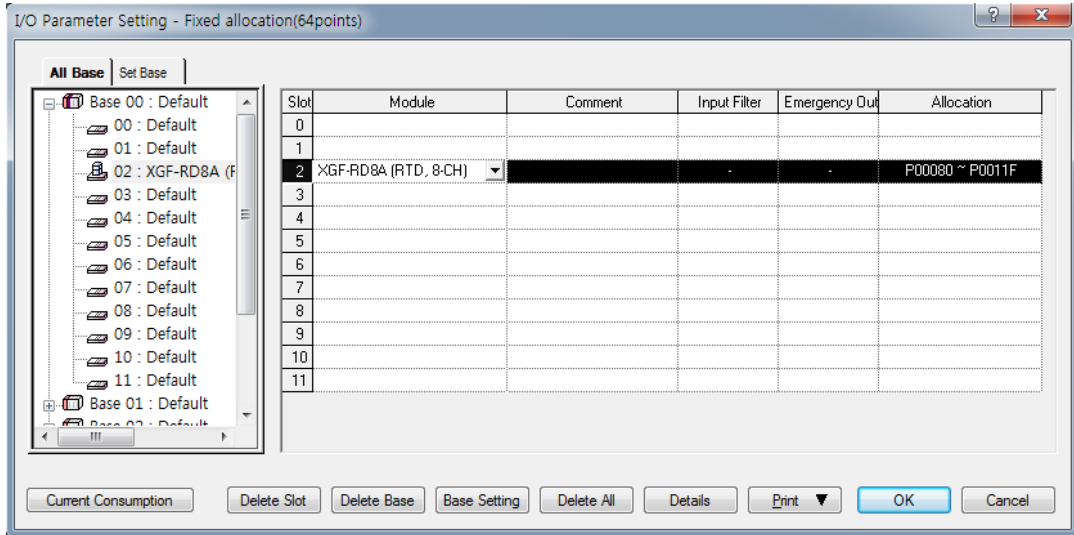

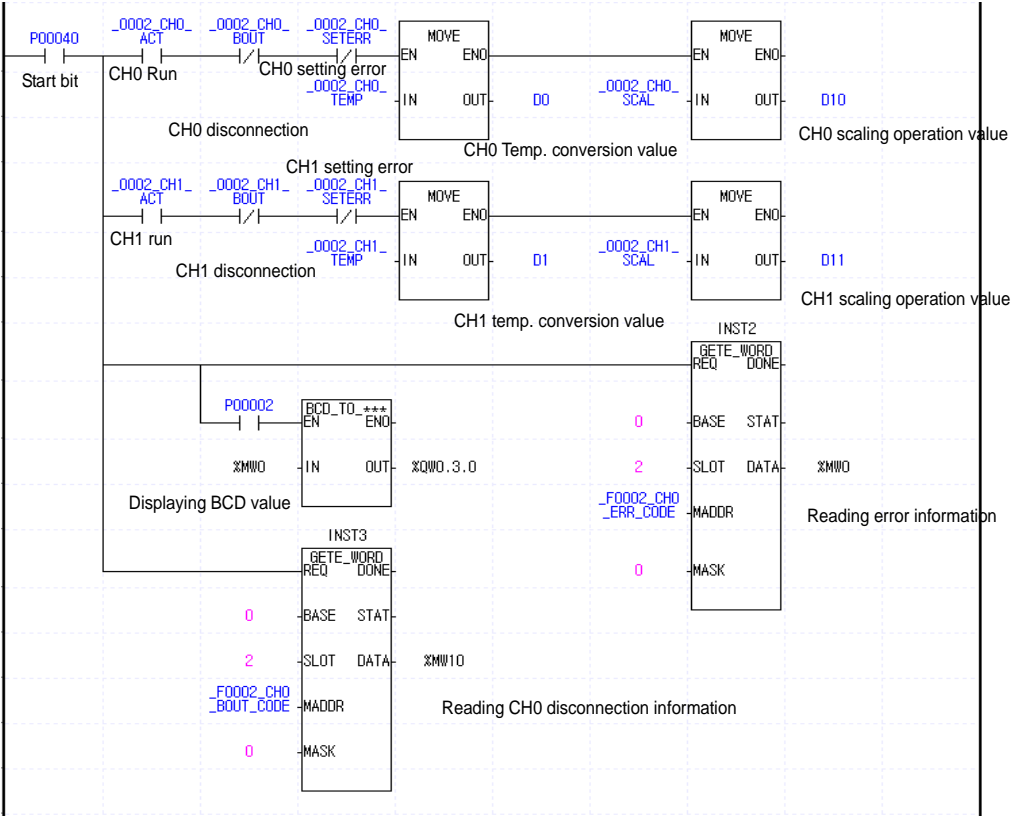

2) Program example using PUT/GET instruction

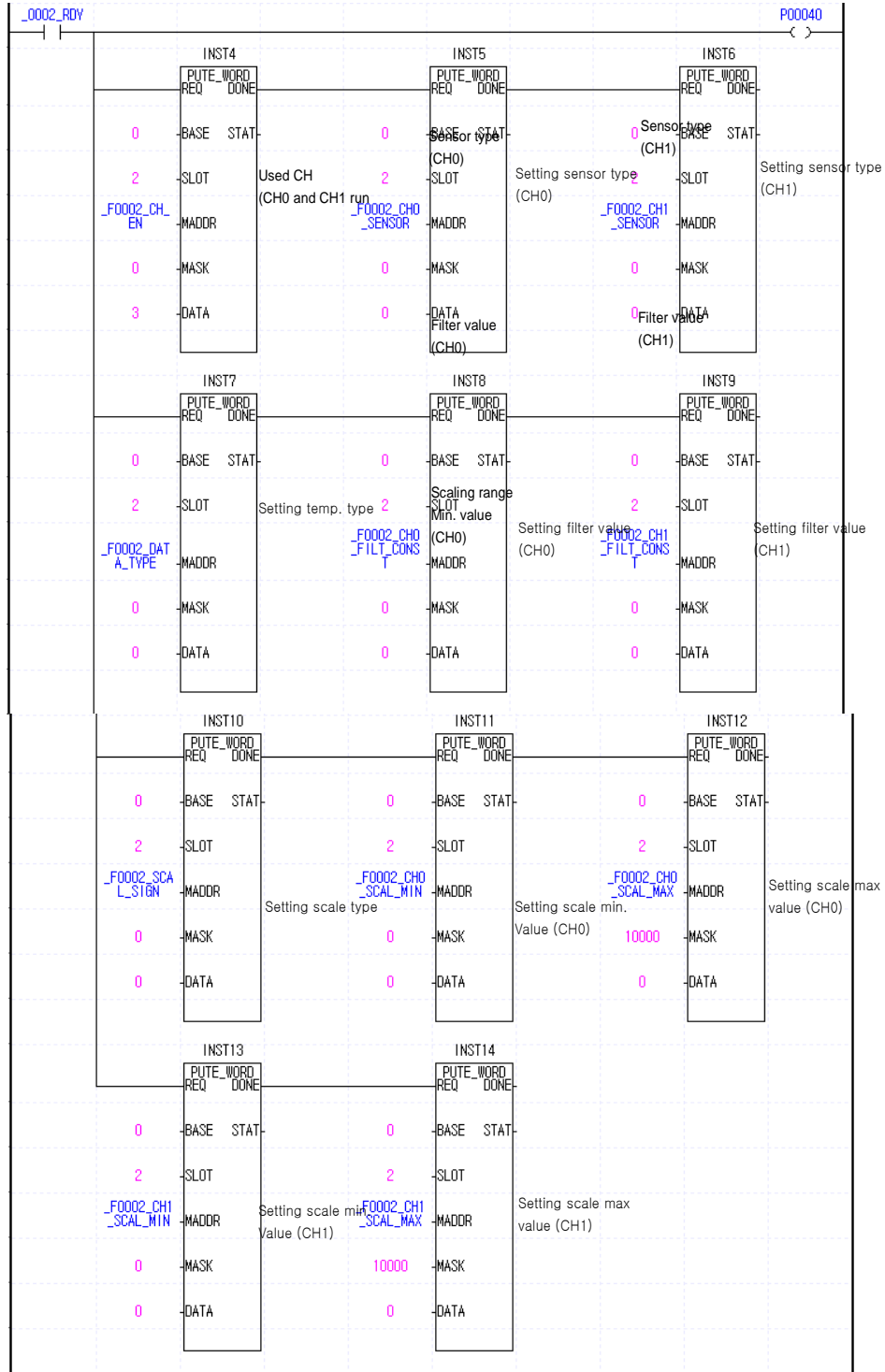

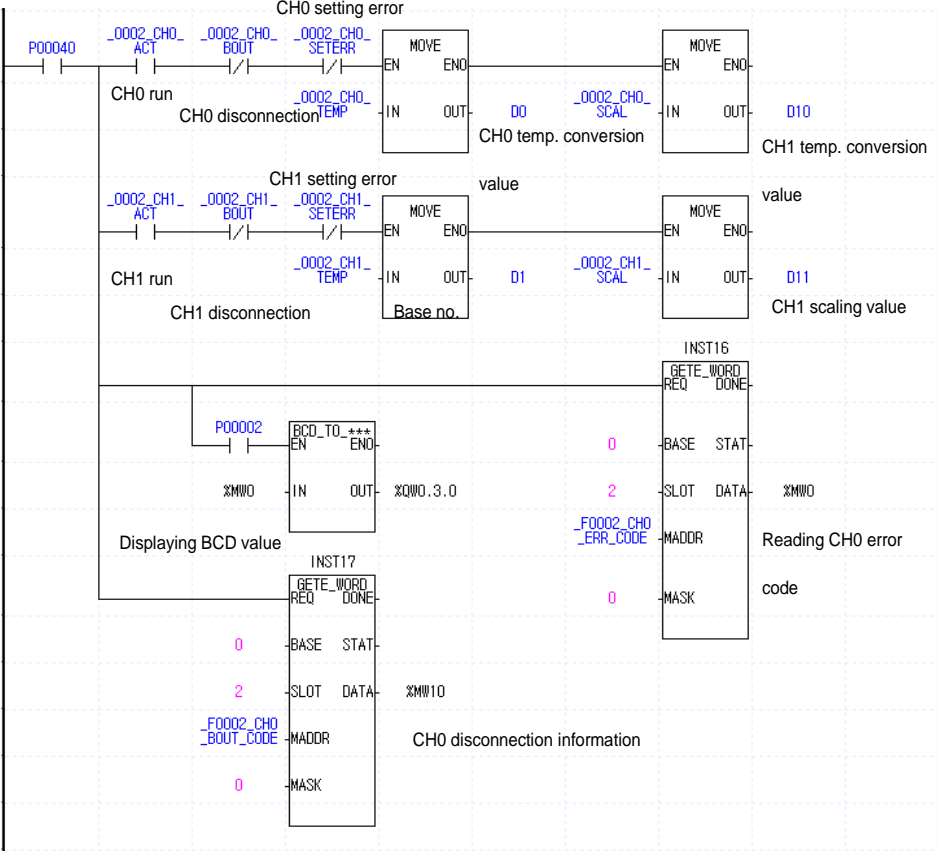

Chapter 9 Troubleshooting

The followings explain errors that could occur during operating the RTD module and their troubleshooting.

9.1 Error Code

Errors indicated by the flickering RUN LED/ALM LED input module are given below.

Error Code (Decimal)	Description	LED	
		RUN	ALM
10	Module error (ASIC Reset Error)	Flickering (0.2sec. cycle)	Off
11	Module error (ASIC RAM)		
12	Module error (Register Error)		
30	Module error (Module Refresh Area Writing Error)		
32	Module error (Module Refresh Area Read Error)		
40	Offset/gain error (EEPROM Check Error)	Flickering (5sec. cycle)	Off

[Table 9. 1] Error code list when hardware error occurs

Error Code (Decimal)	Description	Internal memory address (Operation parameter)	LED	
			RUN	ALM
0	Normal	68 ~ 71	On	Flickering (1s)
1	Sensor A disconnection		On	Flickering (1s)
2	Sensor B disconnection		On	Flickering (1s)

[Table 9. 2] Error code list when disconnection occurs(XGF-RD4A)

Error Code (Decimal)	Description	Internal memory address (Operation parameter)	LED	
			RUN	ALM
0	Normal	68 ~ 71	On	Flickering (1s)
1	Sensor A disconnection		On	Flickering (1s)

[Table 9. 3] Error code list when disconnection occurs(XGF-RD4S)

Error Code (Decimal)	Description	Internal memory address (Operation parameter)	LED	
			RUN	ALM
0	Normal	156~159	On	Off
1	User offset/gain setting expectation lower temperature setting value +10 is less than expectation upper temperature setting value		On	Off
2	User offset/gain setting expectation upper temperature setting value +10 is greater than expectation lower temperature setting value		On	Off
3	Disconnection		On	Flickering

[Table 9. 4] Error code list in case of user offset/gain setting (XGF-RD8A)

9.2 Troubleshooting Procedure

9.2.1 RUN LED flickering

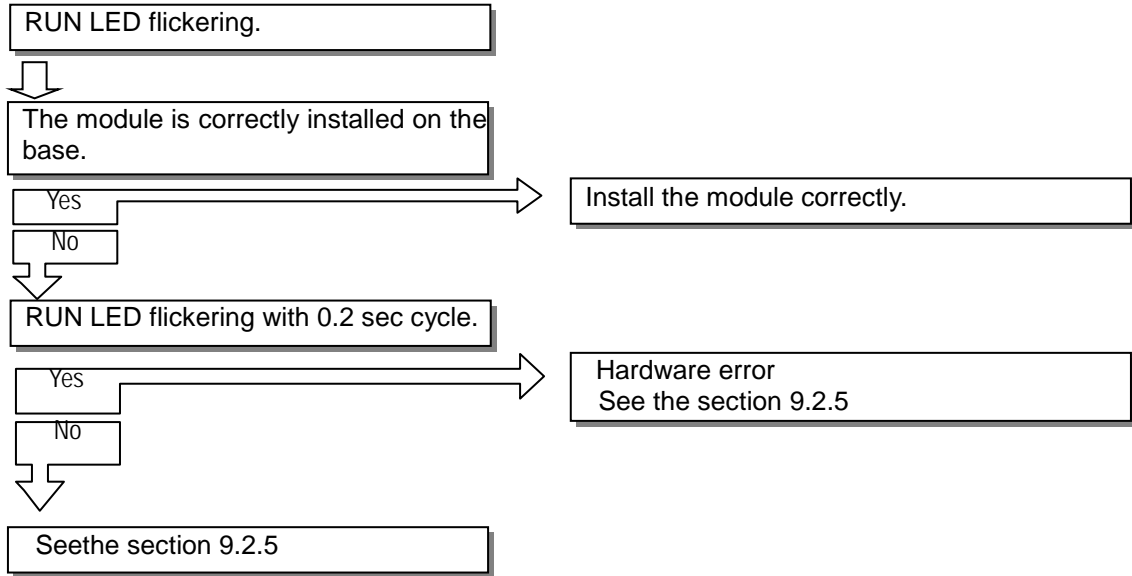

9.2.2 RUN LED off

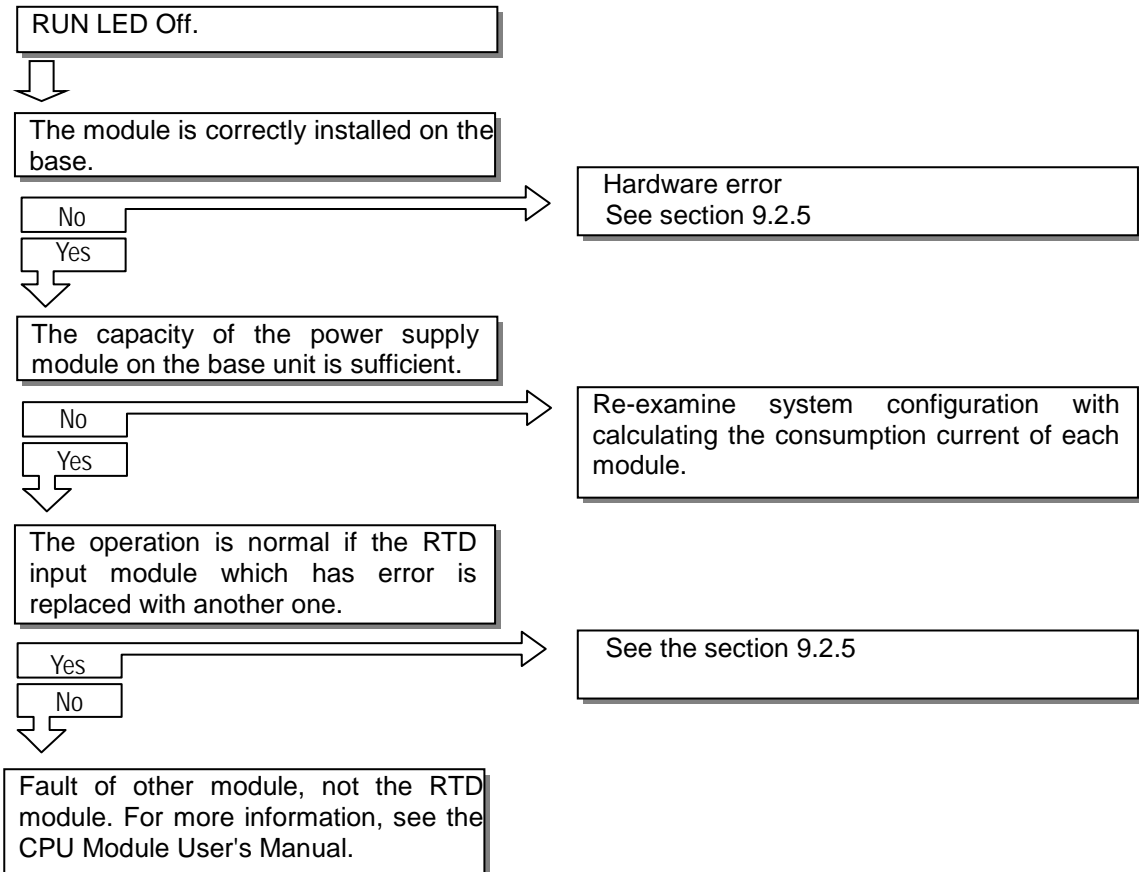

9.2.3 CPU cannot read Temperature conversion value

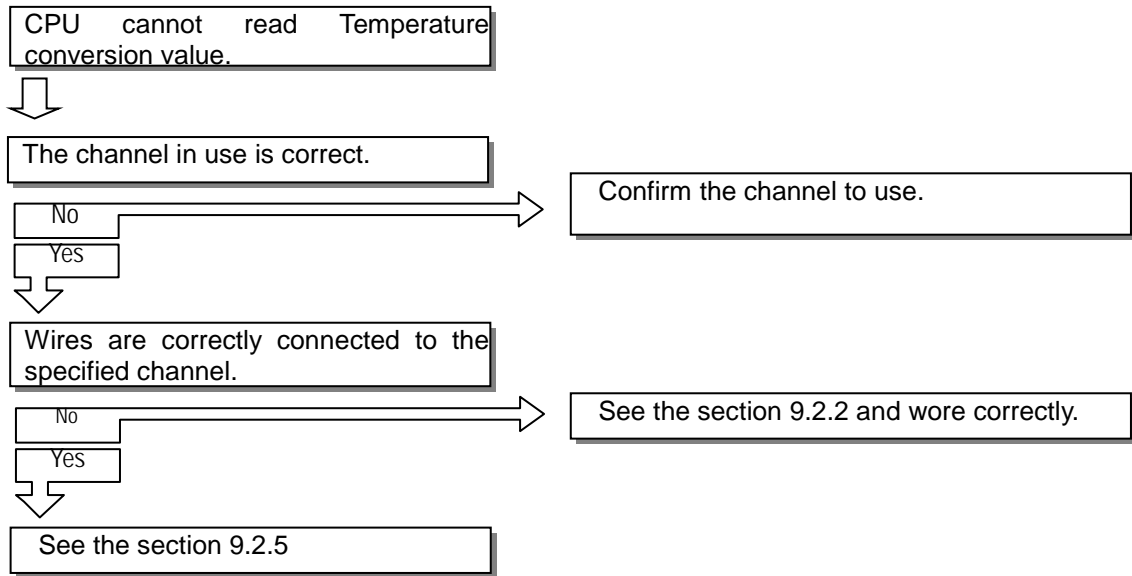

9.2.4 RTD input value and the detected value is not consistent

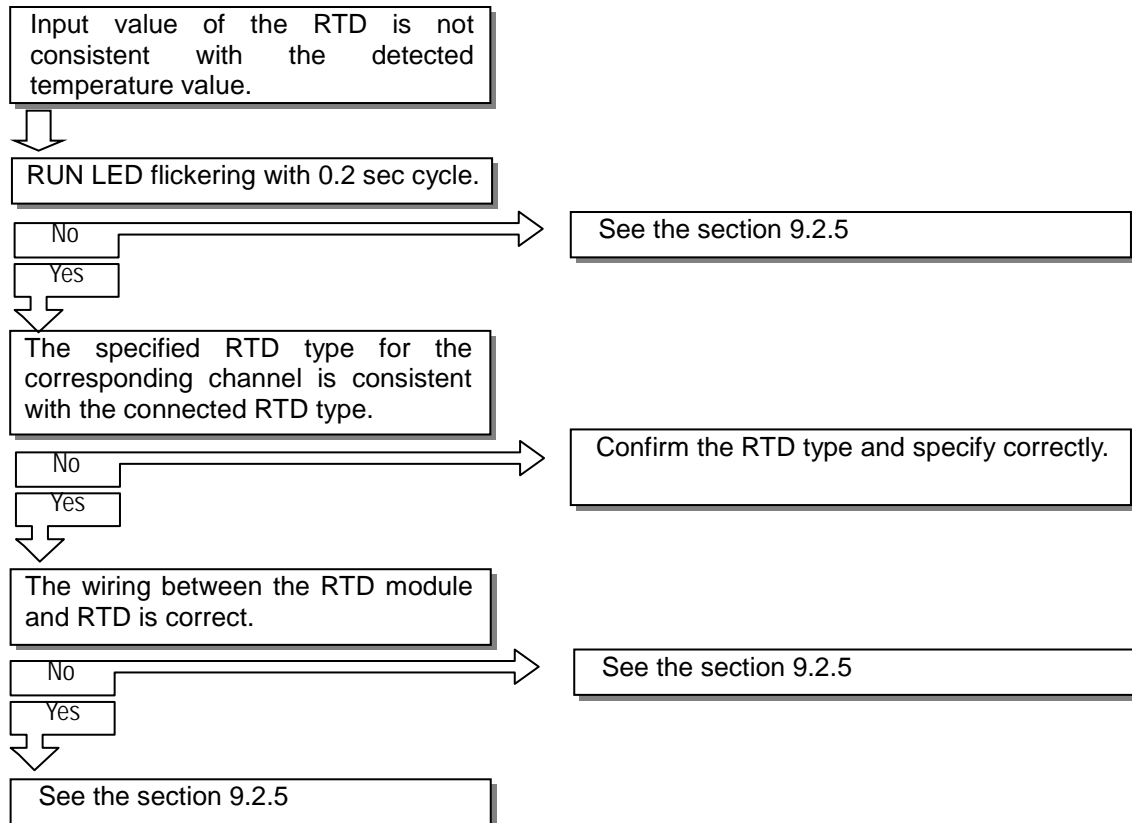

9.2.5 RTD module hardware error

When Hardware error occurs in RTD module, contact the nearest agency or service center of LS Industrial Systems Co. Ltd.,

9.2.6 RTD module status check through XG5000 system monitoring

Module type, module information, O/S version and module status of RTD module can be checked through XG5000 system monitoring function.

1) Execution sequence

Two routes are available for the execution.

- (1) [Monitor] -> [System Monitoring] -> and on the module screen, click the right mouse button to display [Module Information].
- (2) [Monitor] -> [System Monitoring] -> and Double-click the module screen.

2) Module information

- (1) Module Info: shows the information of the module presently installed.
- (2) OS version: shows the O/S version information of RTD module.
- (3) OS date: shows the O/S prepared date of RTD module.
- (4) Module status: shows the present error code. (Refer to 7.1 for detailed error codes)

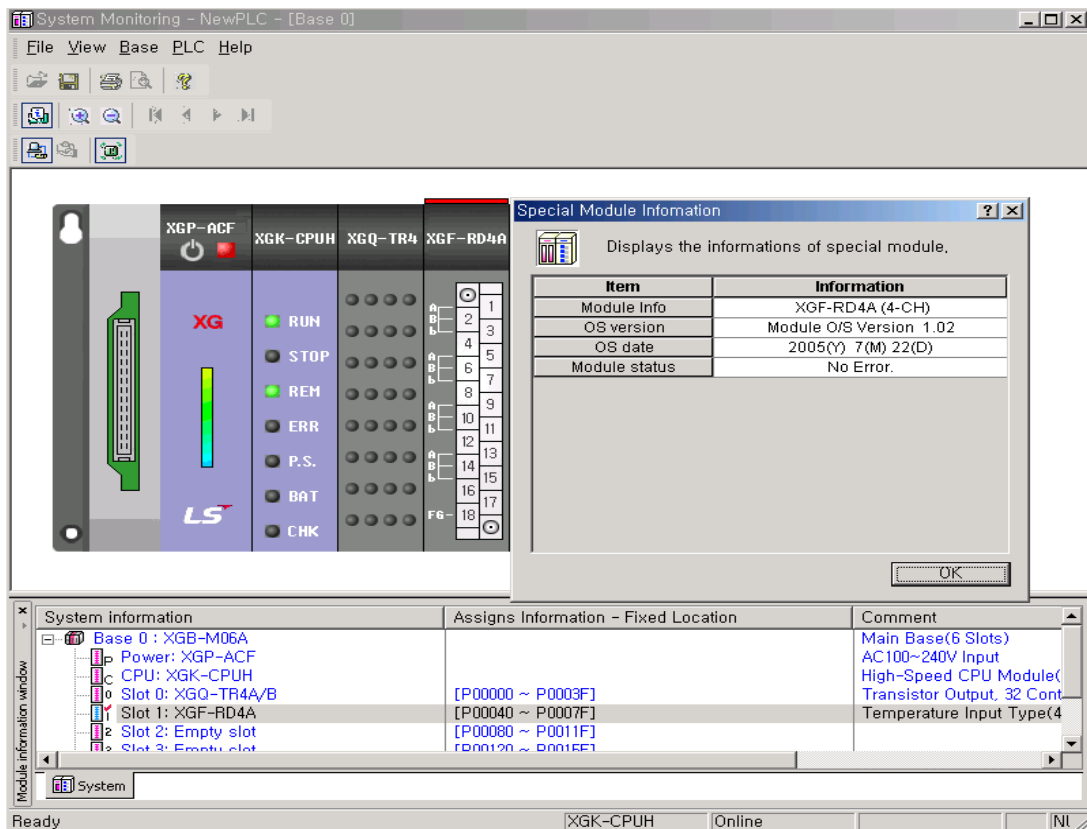

Appendix 1 Standard Resistance Value

Pt100Ω										
-200	18.52									
-100	60.26	56.19	52.11	48.00	43.88	39.72	35.54	31.34	27.10	22.83
0	100.00	96.09	92.55	88.22	84.27	80.31	76.33	72.33	68.33	64.30
Temp.(°C)	0	10	20	30	40	50	60	70	80	90
0	100.00	103.90	107.79	111.67	115.54	119.40	123.24	127.08	130.90	134.71
100	138.51	142.29	146.07	149.83	153.58	157.33	161.05	164.77	168.48	172.17
200	175.86	179.53	183.19	186.84	190.47	194.10	197.71	201.31	204.90	208.48
300	212.05	215.61	219.86	222.68	226.21	229.72	233.21	236.70	240.18	243.64
400	247.09	250.53	253.96	257.38	260.78	264.18	267.56	270.93	274.29	277.64
500	280.98	284.30	287.62	290.92	294.21	297.49	300.75	304.01	307.25	310.49
600	313.71	316.92	320.12	323.30	326.48	329.64	332.79	335.93	339.06	342.18
700	345.28	348.38	351.46	354.53	357.59	360.64	363.67	366.70	369.71	372.71
800	375.70	378.68	381.65	384.60	387.55					
850	390.48									
JPt100Ω										
-200	17.14									
-100	59.57	55.44	51.29	47.11	42.91	38.68	34.42	30.12	25.80	21.46
0	100.00	96.02	92.02	88.01	83.99	79.96	75.91	71.85	67.77	63.68
Temp. (°C)	0	10	20	30	40	50	60	70	80	90
0	100.00	103.97	107.93	111.88	115.81	119.73	123.64	127.54	131.42	135.3
100	139.16	143.01	146.85	150.67	154.49	158.29	162.08	165.86	169.63	173.38
200	177.13	180.86	184.58	188.29	191.99	195.67	199.35	203.01	206.66	210.3
300	213.93	217.51	221.15	224.74	228.32	231.89	235.45	238.99	242.53	246.05
400	249.56	253.06	256.55	260.02	263.49	266.94	270.38	273.8	277.22	280.63
500	284.02	287.4	290.77	294.12	297.47	300.8	304.12	307.43	310.72	314.01
600	317.28	320.54	323.78	327.02	330.24					
649	333.13									

Pt1000Ω										
-200	185.201									
-100	602.558	561.93	521.098	480.048	438.764	397.232	355.433	313.35	270.964	228.255
0	1000	960.859	921.599	882.217	842.707	803.063	763.278	723.345	683.254	642.996
Temp.(°C)	0	10	20	30	40	50	60	70	80	90
0	1000	1039.025	1077.935	1116.729	1155.408	1193.971	1232.419	1270.751	1308.968	1347.069
100	1385.055	1422.925	1460.68	1498.319	1535.843	1573.251	1610.544	1647.721	1684.783	1721.729
200	1758.56	1795.275	1831.875	1868.359	1904.728	1940.981	1977.119	2013.141	2049.048	2084.839
300	2120.515	2156.075	2191.52	2226.849	2262.063	2297.161	2332.144	2367.011	2401.763	2436.399
400	2470.92	2505.325	2539.615	2573.789	2607.848	2641.791	2675.619	2709.331	2742.928	2776.409
500	2809.775	2843.025	2876.16	2909.179	2942.083	2974.871	3007.544	3040.101	3072.543	3104.869
600	3137.08	3169.175	3201.155	3233.019	3264.768	3296.401	3327.919	3359.321	3390.608	3421.779
700	3452.835	3483.775	3514.6	3545.309	3575.903	3606.381	3636.744	3666.991	3697.123	3727.139
800	3757.04	3786.825	3816.495	3846.049	3875.488					
850	3904.811									
Ni100Ω										
-60	69,5									
0	100	94.6	89.3	84.1	79.1	73.8				
Temp.(°C)	0	10	20	30	40	50	60	70	80	90
0	100	105.6	111.2	117.1	123	129.1	135.3	141.7	148.3	154.9
100	161.8	168.8	176	183.3	190.9	198.6	206.6	214.8		
180	223.2									

Appendix 2 Dimension

1) Dimensions of XGF-RD4A

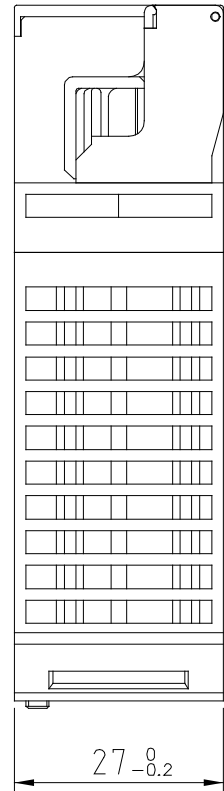
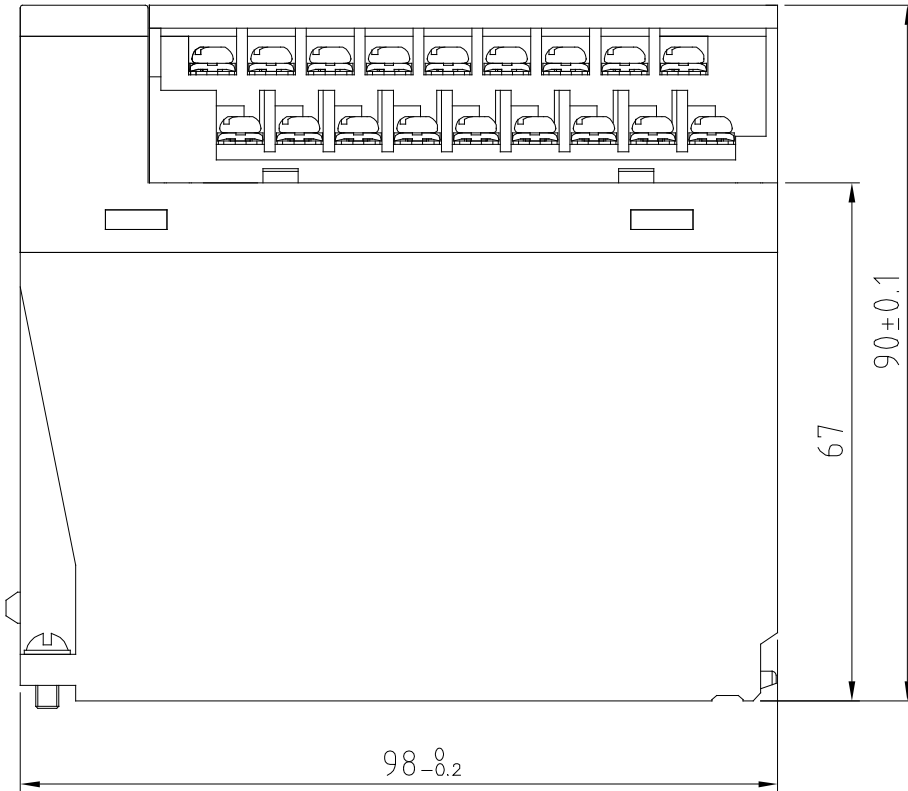
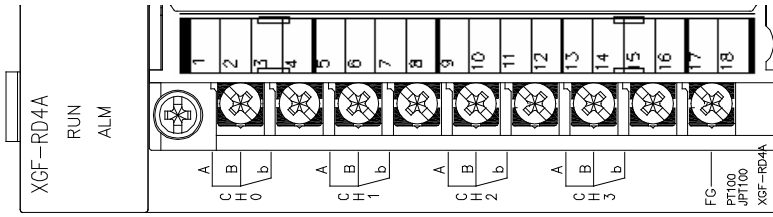

2) Dimensions of XGF-RD4S

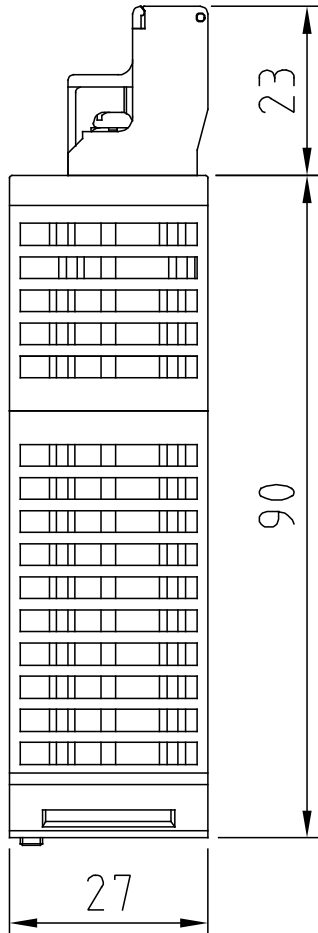
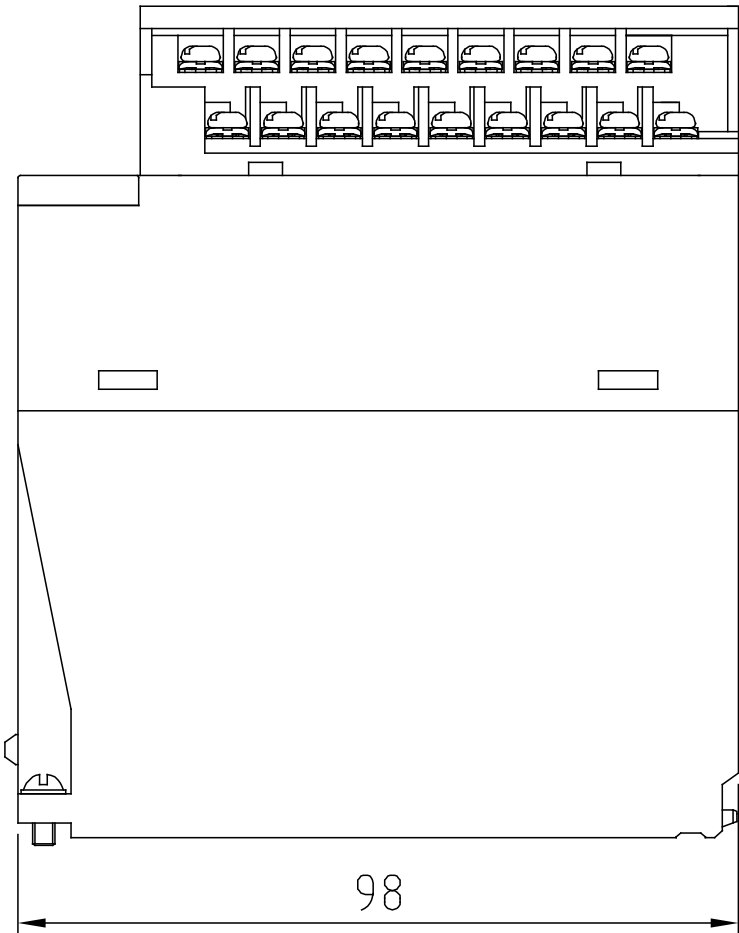
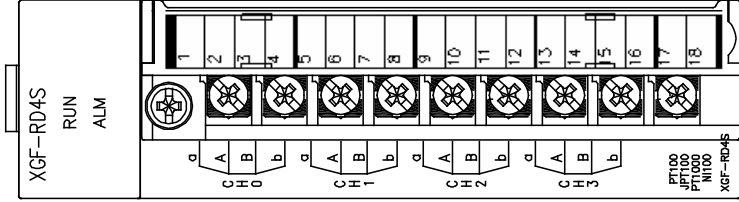

3) Dimensions of XGF-RD8A

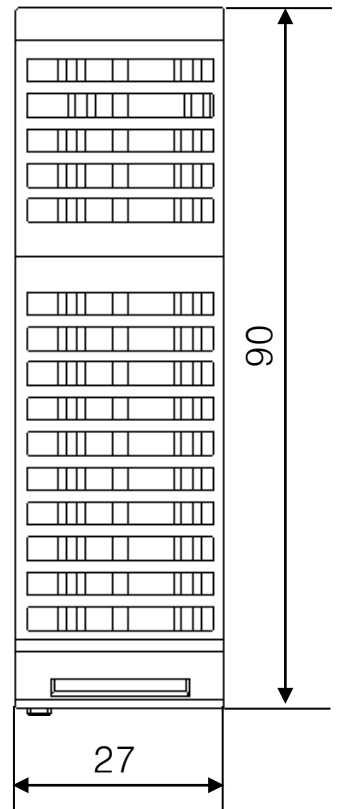
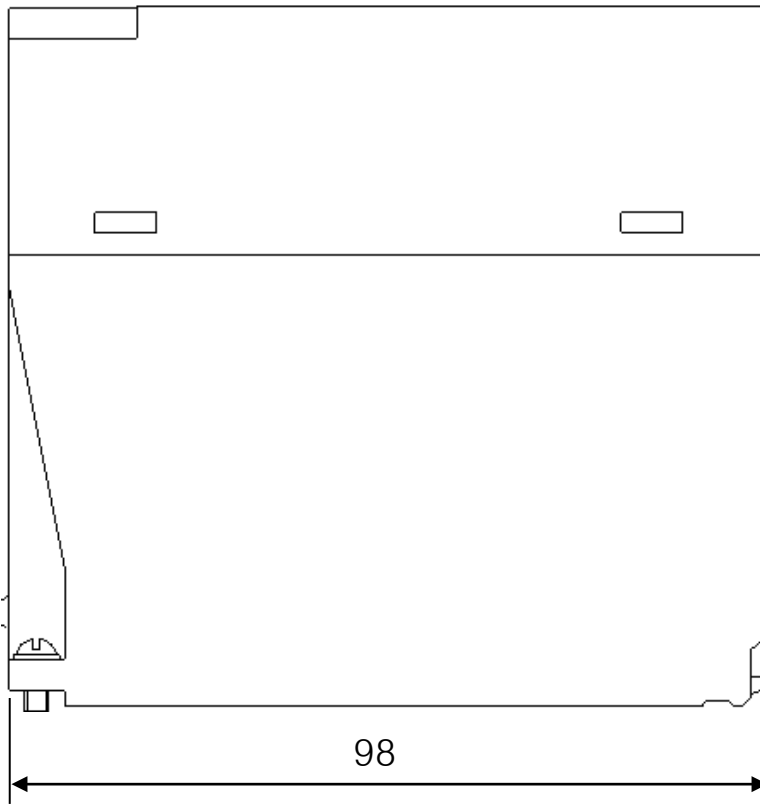
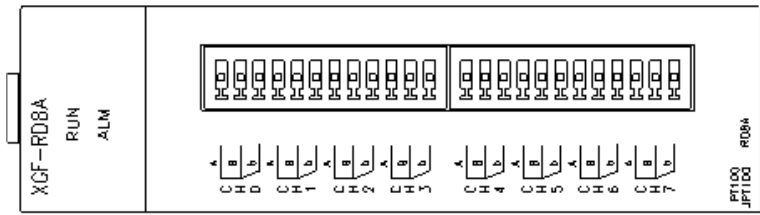

Appendix 3 User Offset and Gain Setting Function

1. User offset and gain setting function

To reduce deviation of temperature conversion value of RTD module, This function provides for user changing temperature conversion value with offset and gain setting function.

In case of changing temperature conversion value with offset and gain setting function, factory setting offset and gain remain without changing.

If using a offset and gain setting function, the range of accuracy satisfy precision only in the offset available lower temperature value ~ available upper temperature value which is set by the user.

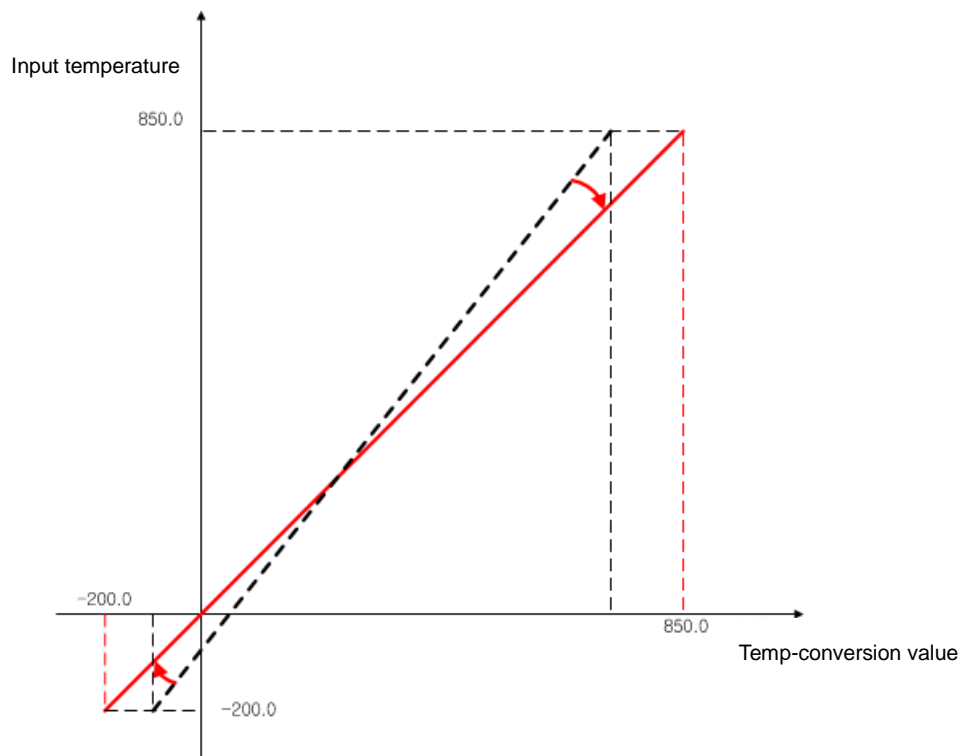

2. Program examples using user offset and gain setting function

In case of setting user offset and gain function, It needs 2-point temperature input device; the gap of 2-point temperature values must be larger than at least 1°C.

Explain the way to set user offset and gain setting function at ch0

2.1 Setting I/O parameter

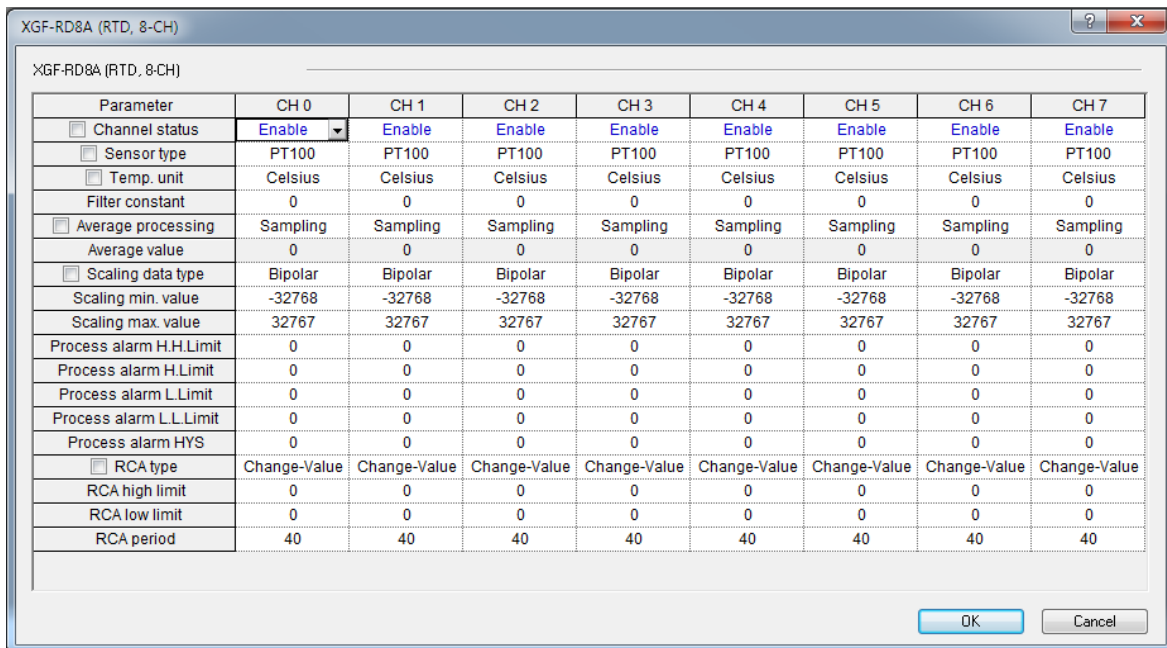
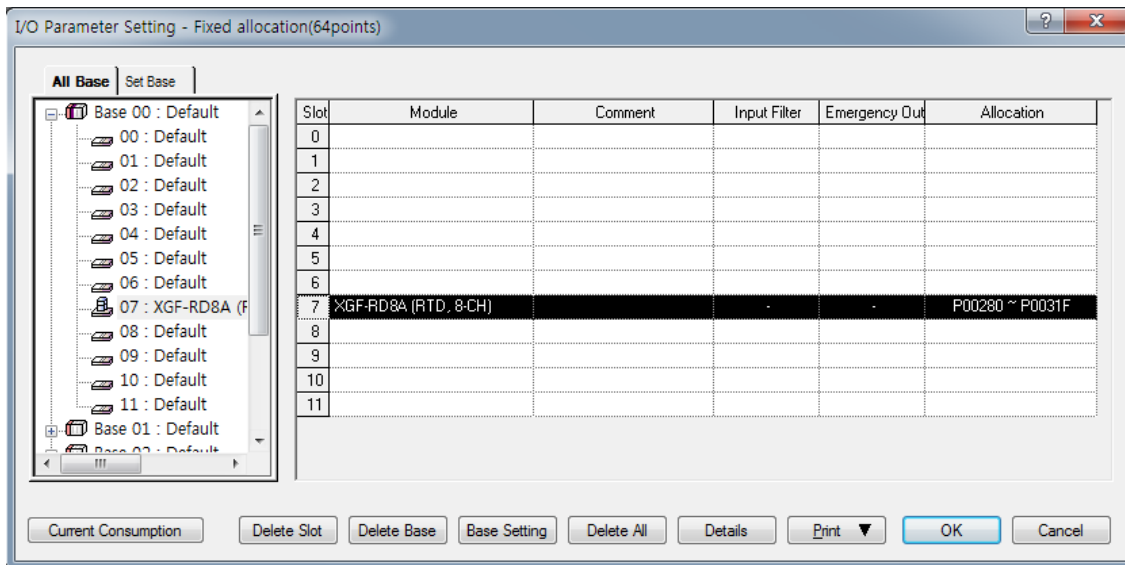

After registering RTD module at installed slot and setting the operation channels, sensor types, and so on in parameter, download program it to PLC.

Appendix3 User Offset and Gain Setting Function

2.2 Using scan program, setting the following order.

(1) In case of using the user offset and gain setting function at channel 0, set to 1 at M0000 bit to start user offset and gain setting function mode.

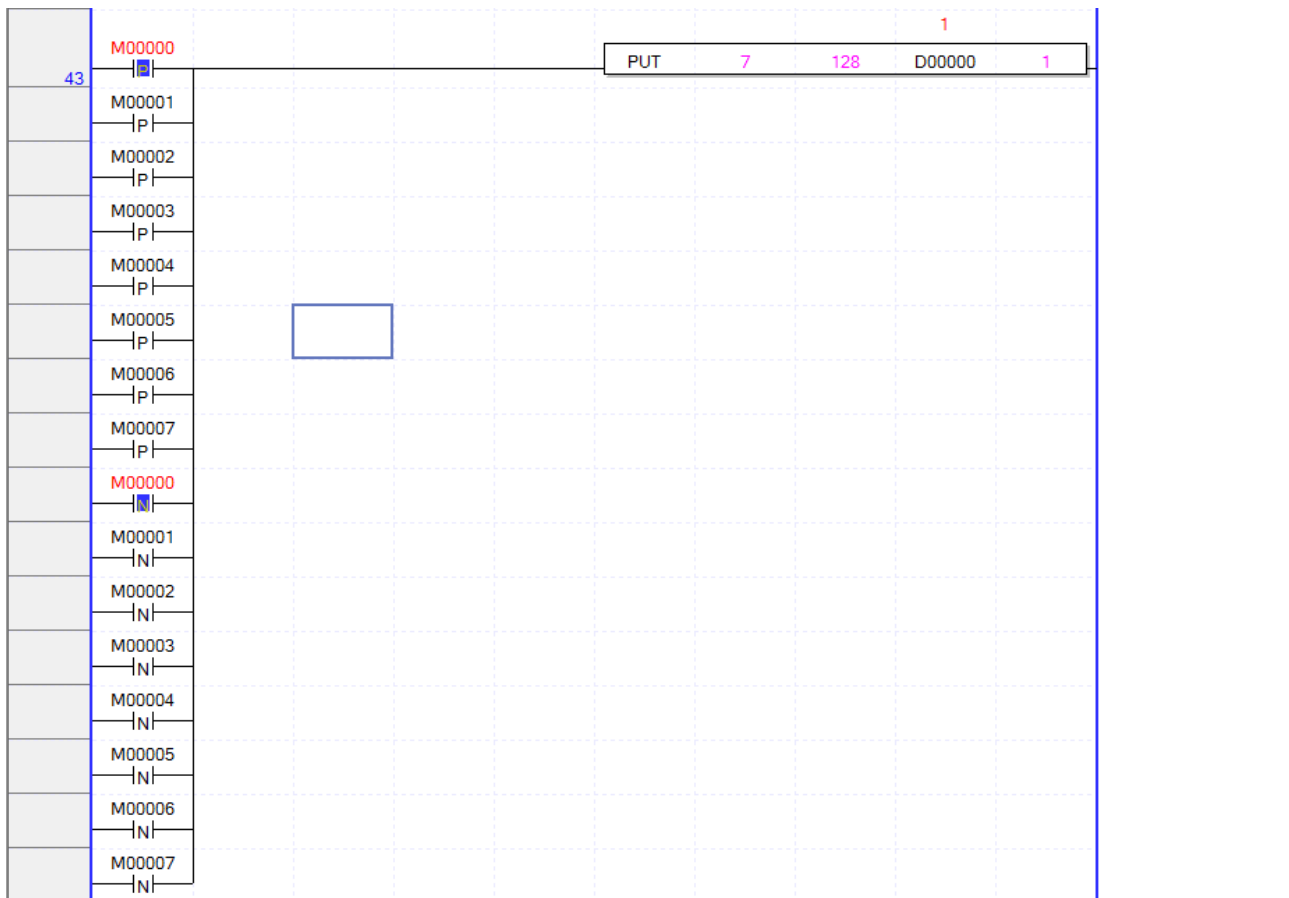

(2) Set to Off at M0010 in order to setting user offset values

Appendix3 User Offset and Gain Setting Function

Comment		The current setting is selected ETU is (set to contact off) ETL or not (contact on setting) when user setoffset gain	
Comment		Depending on the states of the bits and select the channel ETL (off) / ETU and (on)	
67	M00010	D00001.0	Select Ch0 user offset gain setting type
70	M00011	D00001.1	Select Ch1 user offset gain setting type
73	M00012	D00001.2	Select Ch2 user offset gain setting type
76	M00013	D00001.3	Select Ch3 user offset gain setting type
79	M00014	D00001.4	Select Ch4 user offset gain setting type
82	M00015	D00001.5	Select Ch5 user offset gain setting type
85	M00016	D00001.6	Select Ch6 user offset gain setting type
88	M00017	D00001.7	Select Ch7 user offset gain setting type

Comment		Command to change the configuration running on the pulse type	
Comment		Using the PUT command to use only the lower word of memory	
93	M00010	PUT	7 129 D00001 1
	M00011		
	M00012		
	M00013		
	M00014		
	M00015		
	M00016		
	M00017		
	M00010		
	M00011		
	M00012		
	M00013		
	M00014		
	M00015		
	M00016		
	M00017		

(3) After inputting offset values at channel 0, set to 1 at M00040 in order to write offset values of

Appendix3 User Offset and Gain Setting Function

D0004, to RTD module.

For example, if displaying 200°C by input device, input 2000 into D00004

Comment	3. Need to set the (expected) temperature value and the input of the channel according to the type of setting that to offset gain adjustment when the user has set in the configuration / "2" corresponding to the input of the current (expected) temperature value									
Comment	***When you set the bit, it is the channel set									
Comment	***Bit is set, the command, run on the pulse time									
Comment	***In order to use both on / low word of memory, you can use (PUTEP, pulse type) special commands									
Comment	SET ETL									
Comment	- ETL Setting enable range : -2000 ~ 8500(PT100 Type), -2000 ~ 6400(JPT100)									
Comment	-ETL<ETU <input type="text"/>									
150	D00001.0	M00040	PUTE	7	132	0	D00004	1	2000	Set Ch0 ETL value(expectation lower temperature value)
159	D00001.1	M00041	PUTE	7	133	0	D00007	1	0	Set Ch1 ETL value(expectation lower temperature value)
168	D00001.2	M00042	PUTE	7	134	0	D00010	1	0	Set Ch2 ETL value(expectation lower temperature value)
177	D00001.3	M00043	PUTE	7	135	0	D00013	1	0	Set Ch3 ETL value(expectation lower temperature value)
186	D00001.4	M00044	PUTE	7	132	1	D00016	1	0	Set Ch4 ETL value(expectation lower temperature value)
195	D00001.5	M00045	PUTE	7	133	1	D00019	1	0	Set Ch5 ETL value(expectation lower temperature value)
204	D00001.6	M00046	PUTE	7	134	1	D00022	1	0	Set Ch6 ETL value(expectation lower temperature value)
213	D00001.7	M00047	PUTE	7	135	1	D00025	1	0	Set Ch7 ETL value(expectation lower temperature value)

(4) First of all, set to 1 at M00020 in order to set designated bits for offset setting channels and then set to 1 at M00500 in order to set user offset values.

If setting completed, D00003.0 set to 1 and D00076 of setting count device will increase to 1.

When completed previous step, set M00020 and M00500 to 0

Normal user offset values are saves unless error code should not occur in D00084.

If occur to error code in D00084, user offset values keep previous values.

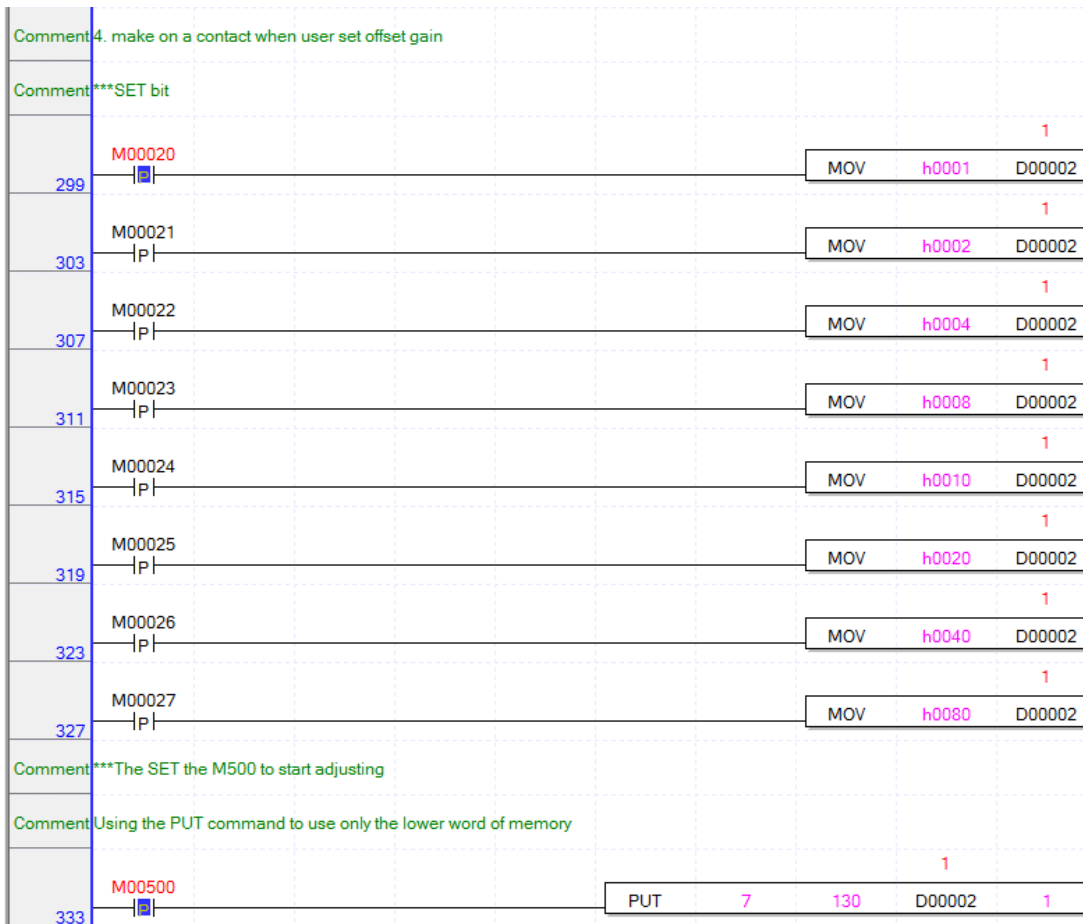

Appendix3 User Offset and Gain Setting Function

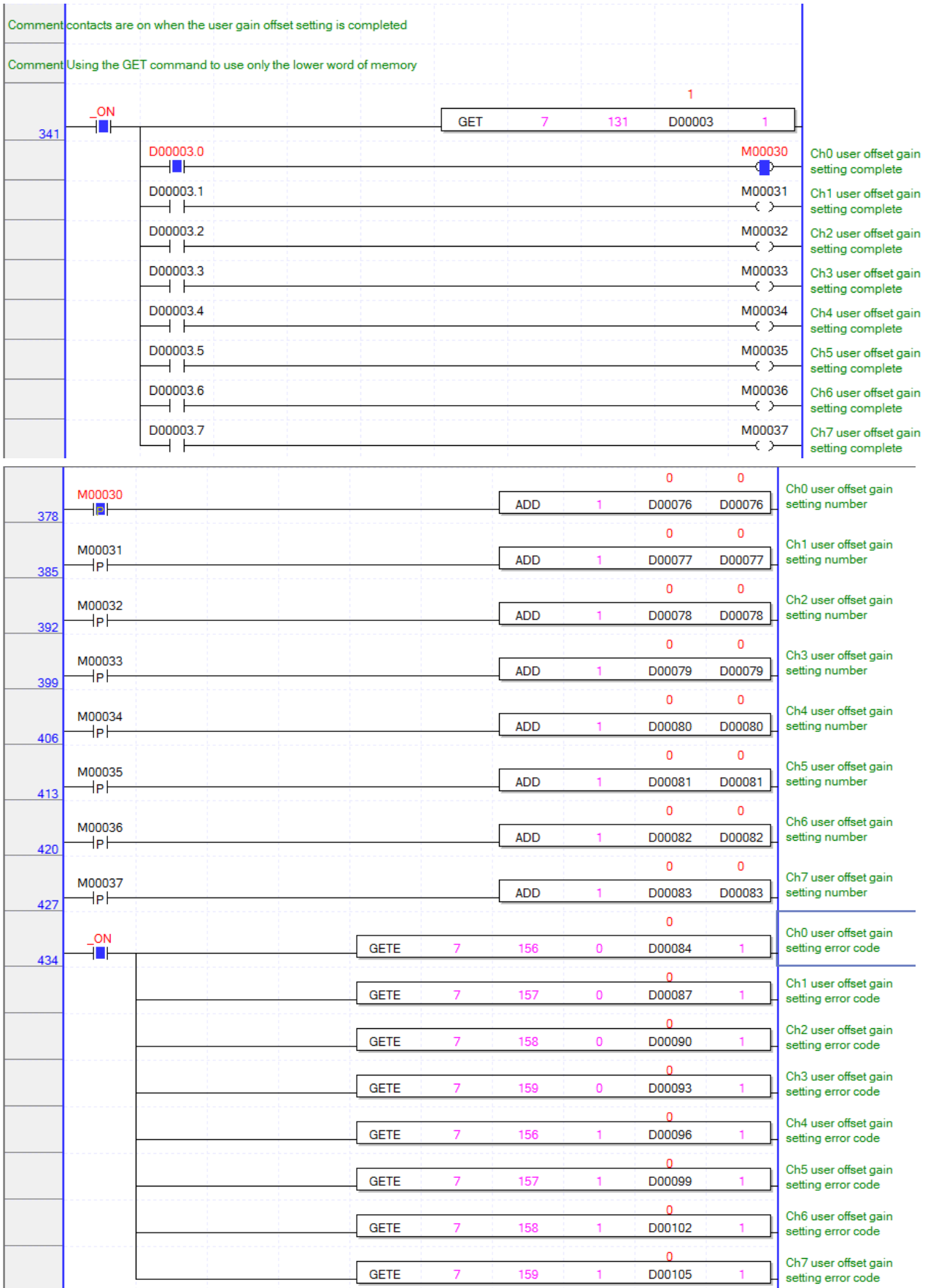

(5) In order to set user gain values, set M00000 to 1 for selecting user offset and gain setting mode.

Set M00010 to 1 with a view to setting user gain values

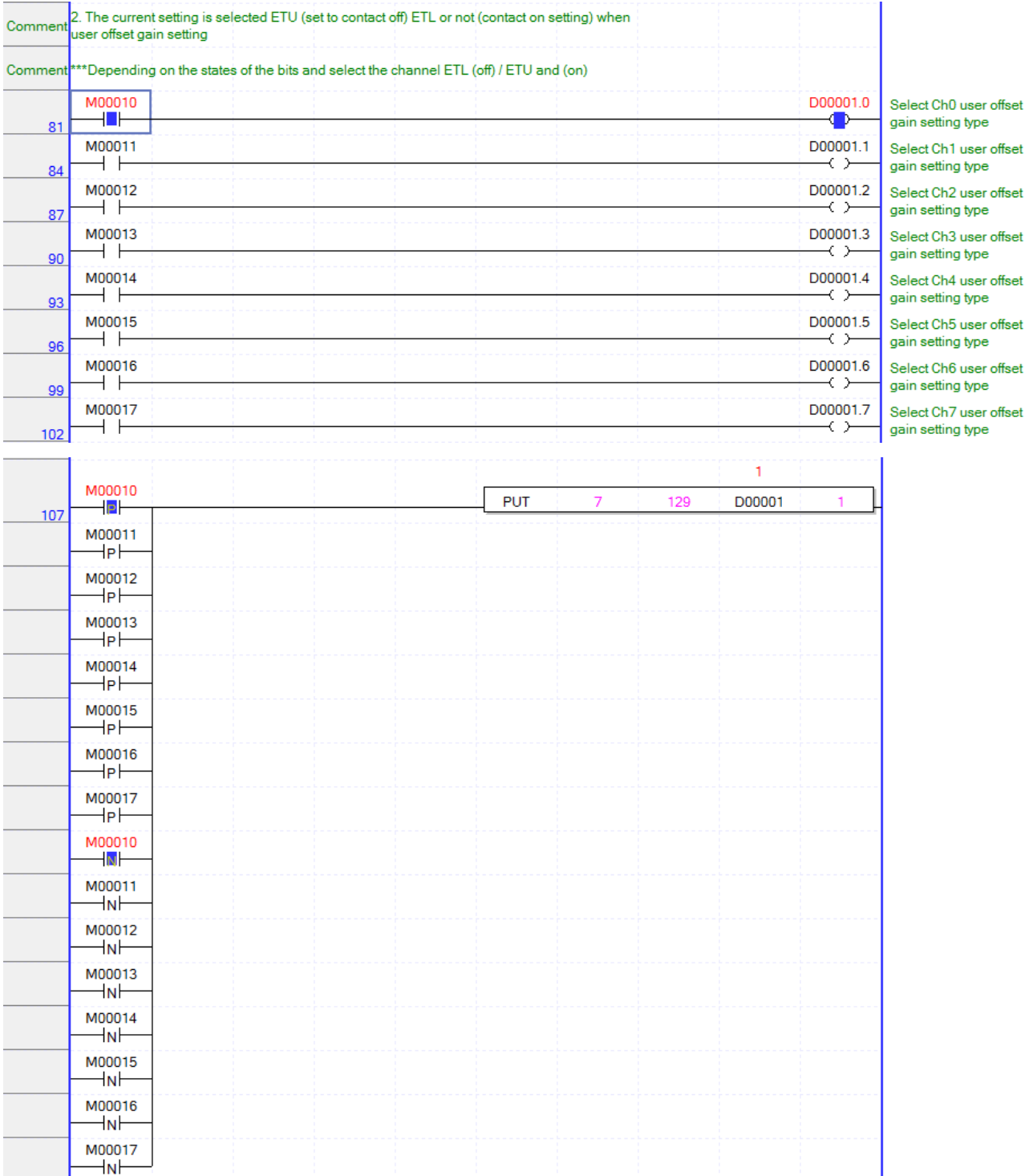

Appendix3 User Offset and Gain Setting Function

(6) After inputting gain values at channel 0, set to 1 at M00050 in order to write gain values of D00028 to RTD module.

For example, if displaying 350°C by input device, input 3500 into D00004

The value of user gain must be larger than user offset value at least 1°C unless do not occur error



(7) First of all, set to 1 at M00020 in order to set designated bits for gain setting channels and then set to 1 at M00500 in order to set user gain values.

If setting completed, D00003.0 set to 1 and D00076 of setting count device will increase to 1.

When completed previous step, set M00020 and M00500 to 0

Normal user gain values are saves unless error code should not occur in D00084.

If occur to error code in D00084, user gain values keep previous values.

Appendix3 User Offset and Gain Setting Function

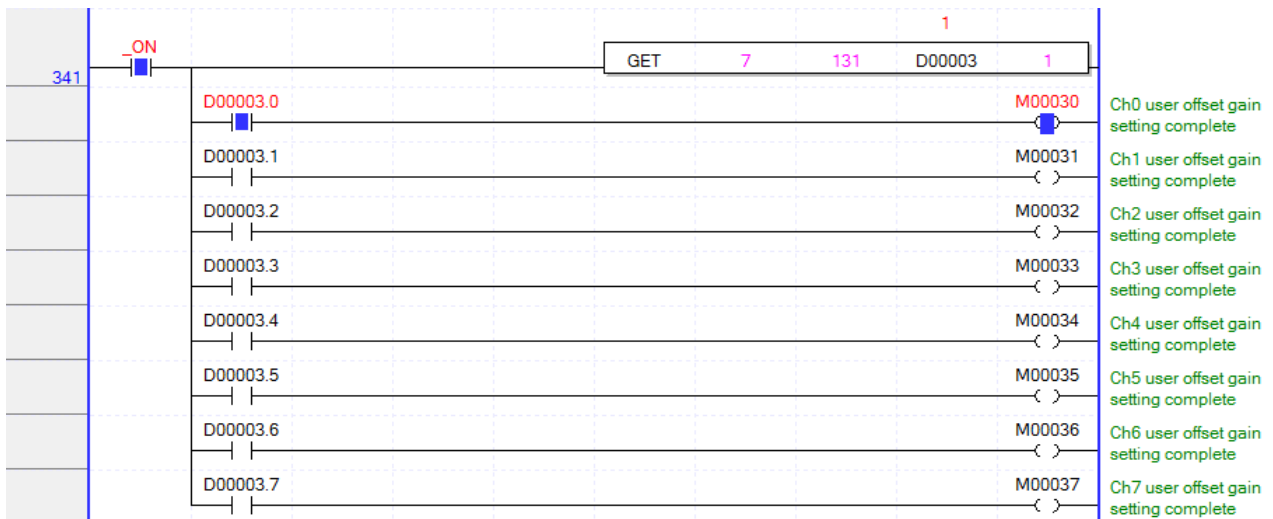
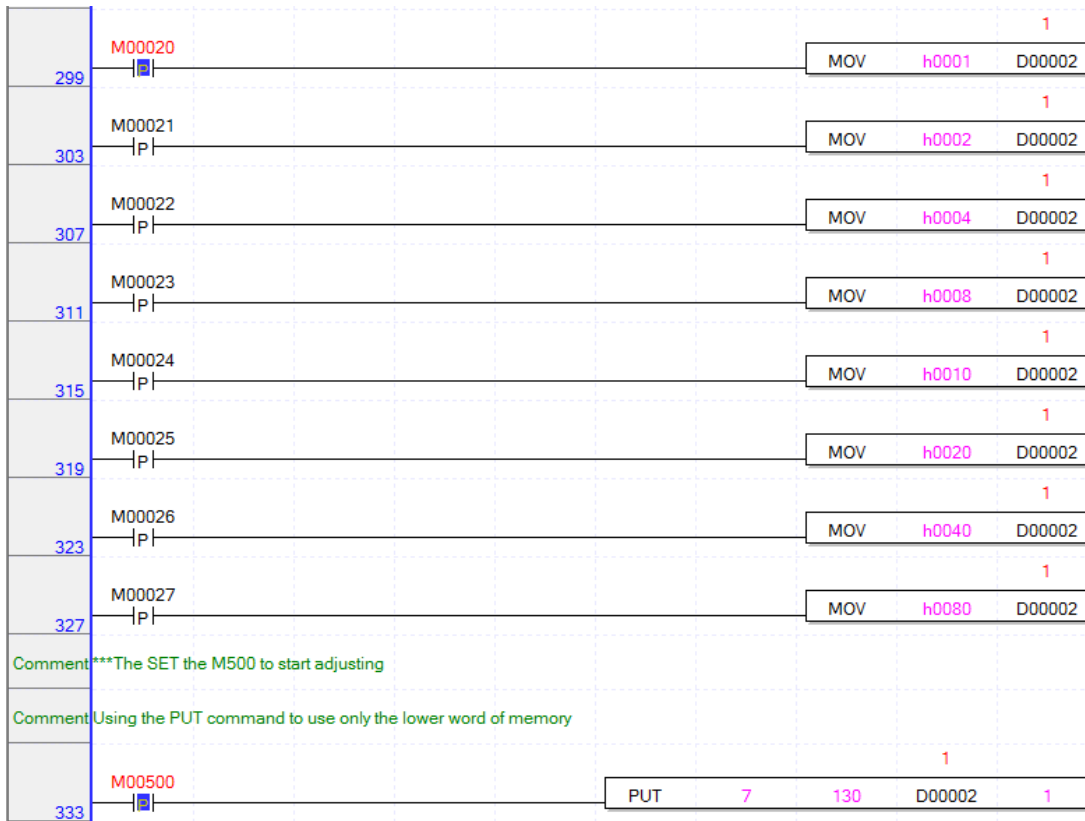

Appendix3 User Offset and Gain Setting Function

378	M00030						2	2	Ch0 user offset gain setting number
		ADD	1	D00076	D00076				
385	M00031						0	0	Ch1 user offset gain setting number
		ADD	1	D00077	D00077				
392	M00032						0	0	Ch2 user offset gain setting number
		ADD	1	D00078	D00078				
399	M00033						0	0	Ch3 user offset gain setting number
		ADD	1	D00079	D00079				
406	M00034						0	0	Ch4 user offset gain setting number
		ADD	1	D00080	D00080				
413	M00035						0	0	Ch5 user offset gain setting number
		ADD	1	D00081	D00081				
420	M00036						0	0	Ch6 user offset gain setting number
		ADD	1	D00082	D00082				
427	M00037						0	0	Ch7 user offset gain setting number
		ADD	1	D00083	D00083				
434	-ON						0		Ch0 user offset gain setting error code
		GETE	7	156	0	D00084	1		
		GETE	7	157	0	D00087	1		Ch1 user offset gain setting error code
		GETE	7	158	0	D00090	1		Ch2 user offset gain setting error code
		GETE	7	159	0	D00093	1		Ch3 user offset gain setting error code
		GETE	7	156	1	D00096	1		Ch4 user offset gain setting error code
		GETE	7	157	1	D00099	1		Ch5 user offset gain setting error code
		GETE	7	158	1	D00102	1		Ch6 user offset gain setting error code
		GETE	7	159	1	D00105	1		Ch7 user offset gain setting error code

(8) In order to save setting values into user offset and gain values, set M00060 to 1.

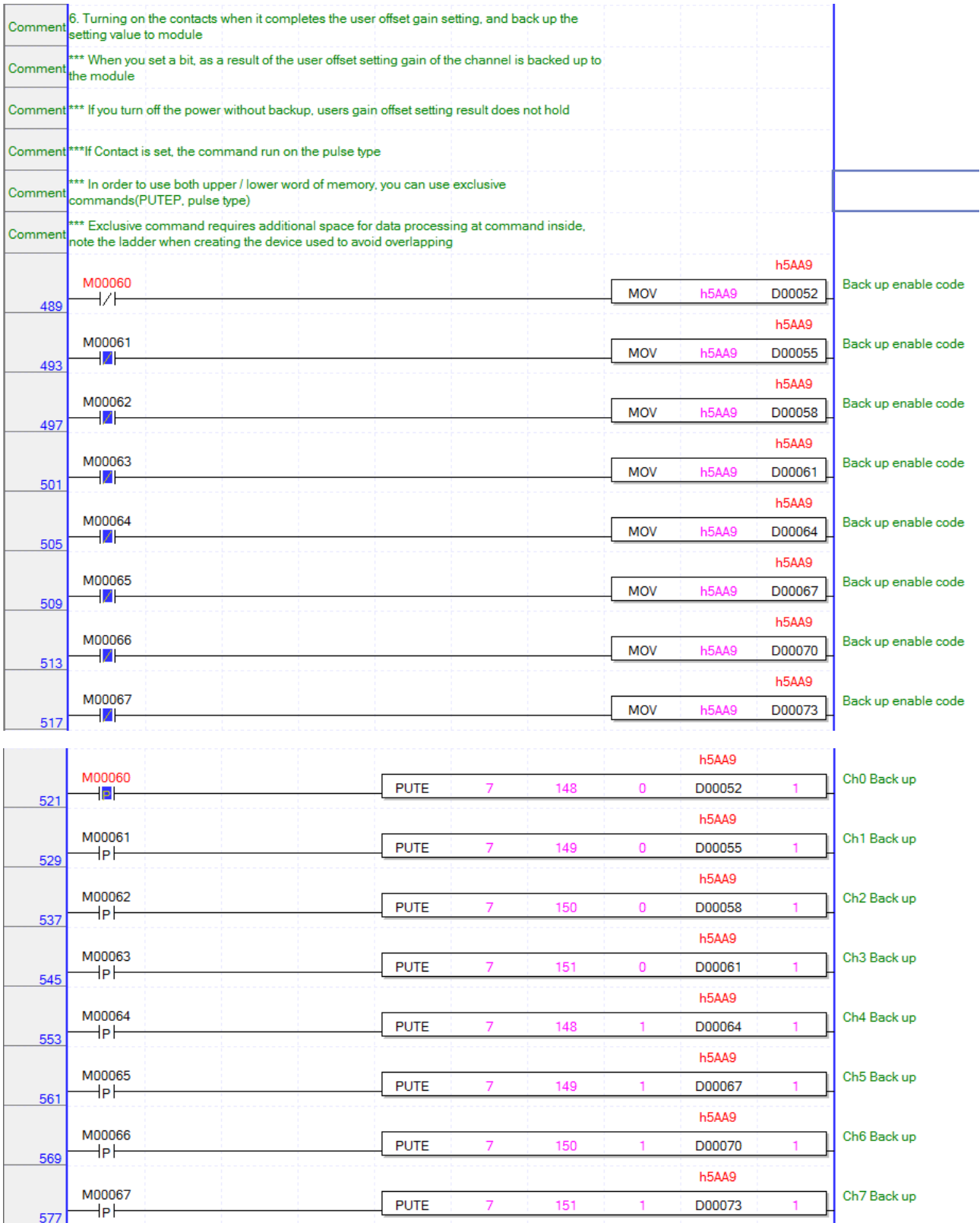

Appendix3 User Offset and Gain Setting Function

- (9) In case of setting the user offset and gain value, if user offset value is larger than the first setting of user gain value or if user gain value is smaller than the first setting of user offset value, setting error occur and do not save the setting value.

Error code list of user offset and gain setting in XGF-RD8A

Error code (decimal)	Description	Internal memory address (operation parameter)	LED status	
			RUN	ALM
0	Normal run	156 ~ 159	On	Off
1	User offset/gain setting expectation lower temperature setting value +10 is less than expectation upper temperature setting value		On	Off
2	User offset/gain setting expectation upper temperature setting value +10 is greater than expectation lower temperature setting value		On	Off
3	Disconnection		On	Flickering

3. User offset and gain setting function by online module change

User offset and gain setting function by online module change move user offset and gain values of RTD module which already has completed setting to another RTD modules.

4. Program examples using user offset and gain setting function by online module change with XGK CPU

Explain Program examples to move user offset and gain values of one RTD module to those of another RTD module. This function is useful for setting offset and gain values of several RTD module at the same user offset and gain values.

- (1) Download program after installed RTD Module at slot no. 7 which finished user offset and gain setting.
- (2) If M00000 set to 1, Read upload offset and gain values of RTD module which already finished user Offset and gain setting.

Comment		Confirm user scaling module change function						
Comment		Process that transfers module B the value of the A module user scaling value is set						
Comment		1. Read user scaling UP value of the previous module(A) and save						
Comment		Device that stores the data read must be set in the latch region						
Comment		Contact M0 : Manual trigger						
883	M00000	GETE	7	h00E6	0	D00000	4	CH0 UP ETL ~ CH3 UP ETL
		GETE	7	h00E6	1	D00014	4	CH4 UP ETL ~ CH7 UP ETL
		GETE	7	h00EA	0	D00030	4	CH0 UP ETU ~ CH3 UP ETL
		GETE	7	h00EA	1	D00044	4	CH4 UP ETU ~ CH7 UP ETL
		GETE	7	h00EE	0	D00060	4	CH0 UP SCNTL ~ CH3 UP SCNTL
		GETE	7	h00EE	1	D00084	4	CH4 UP SCNTL ~ CH7 UP SCNTL
		GETE	7	h00F6	0	D00110	4	CH0 UP SCNTU ~ CH3 UP SCNTU
		GETE	7	h00F6	1	D00134	4	CH4 UP SCNTU ~ CH7 UP SCNTU

A module	1	2	3	4	5	6	7	8	9	
	00000	00010	00020	00030	00040	00050	00060	00070	00080	00090
	00000	00010	00020	00030	00040	00050	00060	00070	00080	00090
	00000	00010	00020	00030	00040	00050	00060	00070	00080	00090
	00000	00010	00020	00030	00040	00050	00060	00070	00080	00090
	00000	00010	00020	00030	00040	00050	00060	00070	00080	00090
	00000	00010	00020	00030	00040	00050	00060	00070	00080	00090
	00000	00010	00020	00030	00040	00050	00060	00070	00080	00090
	00000	00010	00020	00030	00040	00050	00060	00070	00080	00090
	00000	00010	00020	00030	00040	00050	00060	00070	00080	00090
	00000	00010	00020	00030	00040	00050	00060	00070	00080	00090

Offset / gain count lower limit for uploading online module replacement
 Offset / gain count upper limit for uploading online module replacement
 Offset / gain count lower limit for downloading online module replacement
 Offset / gain count upper limit for downloading online module replacement

- (3) Select Module Changing Wizard on the online window.
- (4) After selecting the removing module, click next button.

Appendix3 User Offset and Gain Setting Function

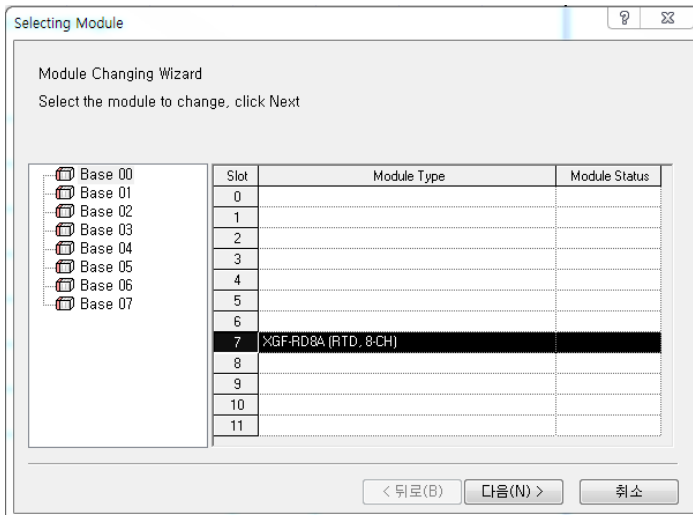

(5) After confirming the module, Click next button.

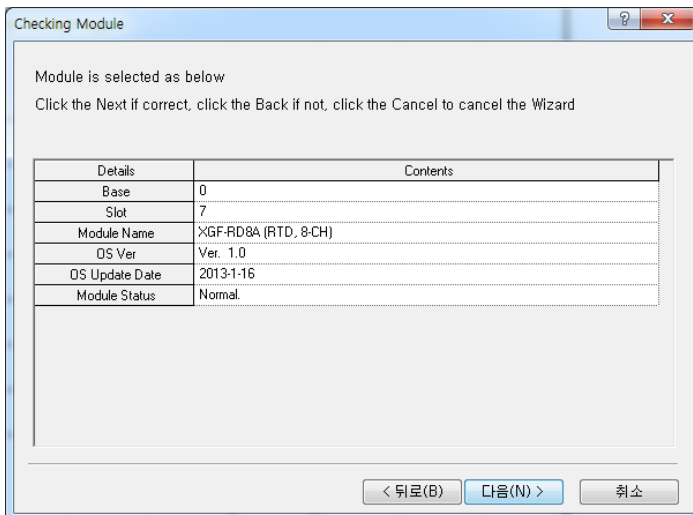

(6) After removing the module, Click next button.



(7) After stalling the changed module, Click next button.

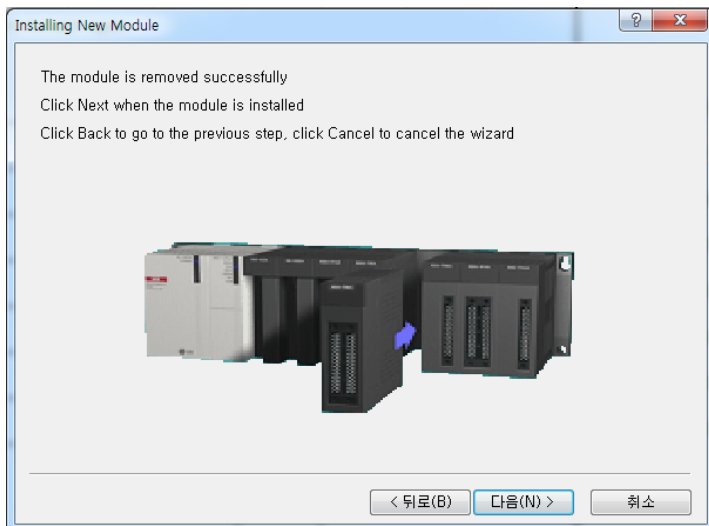

(8) Click the finish button.



(9) In case of using the user offset and gain setting function by online module change, set to 1 at M0001 bit to start user offset and gain setting function mode.

If M0002 set to 1, start to save user offset and gain value and when M0003 set to 1, read saved data of changed module.

Appendix3 User Offset and Gain Setting Function

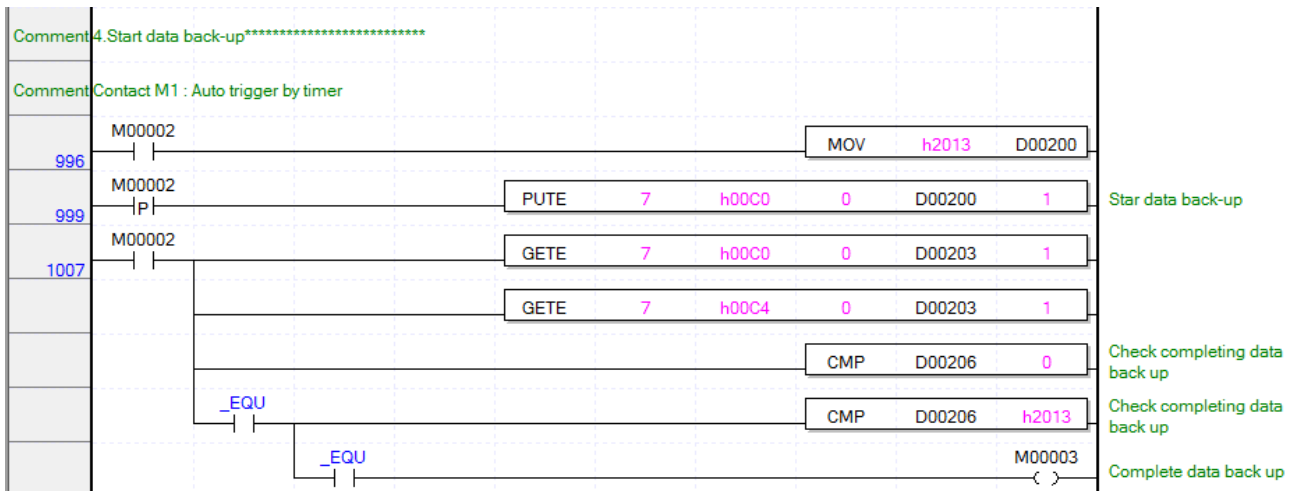

Appendix3 User Offset and Gain Setting Function

Comment5. Read UP region data of changing module(B)									
1029	M00003 P	GETE	7	h00E6	0	D01000	4	CH0 UP ETL ~ CH3 UP ETL	
		GETE	7	h00E6	1	D01014	4	CH4 UP ETL ~ CH7 UP ETL	
		GETE	7	h00EA	0	D01030	4	CH0 UP ETU ~ CH3 UP ETL	
		GETE	7	h00EA	1	D01044	4	CH4 UP ETU ~ CH7 UP ETL	
		GETE	7	h00EE	0	D01060	8	CH0 UP ETL ~ CH3 UP ETL	
		GETE	7	h00EE	1	D01084	8	CH4 UP ETL ~ CH7 UP ETL	
		GETE	7	h00F6	0	D01110	8	CH0 UP ETU ~ CH3 UP ETL	
		GETE	7	h00F6	1	D01134	8	CH4 UP ETU ~ CH7 UP ETL	
Comment6. Read DN region data of changing module(B)									
1080	M00003 P	GETE	7	h00C8	0	D02000	4	CH0 DN ETL ~ CH3 DN ETL	
		GETE	7	h00C8	1	D02014	4	CH4 DN ETL ~ CH7 DN ETL	
		GETE	7	h00CC	0	D02030	4	CH0 DN ETU ~ CH3 DN ETL	
		GETE	7	h00CC	1	D02044	4	CH4 DN ETU ~ CH7 DN ETL	
		GETE	7	h0000	0	D02060	8	CH0 DN SCNTL ~ CH3 DN SCNTL	
		GETE	7	h0000	1	D02084	8	CH4 DN SCNTL ~ CH7 DN SCNTL	
		GETE	7	h0008	0	D02110	8	CH0 DN SCNTU ~ CH3 DN SCNTU	
		GETE	7	h0008	1	D02134	8	CH4 DN SCNTU ~ CH7 DN SCNTU	
1130		END							

Result after Module change(A-->B)

1	00000	h0000	00001	130041	00002	113045	00003	130649	00004	207301	00005	157022	00006	630029	00007	709041	Offset / gain count lower limit for uploading of online module A module replacement
2	00010	h0050	00011	154206	00012	126452	00013	130447	00014	157042	00015	630179	00016	712025	00017	709076	Offset / gain count upper limit for uploading of online module A module replacement
3	00020	h0050	00021	130043	00022	113045	00023	126646	00024	207301	00025	157022	00026	630029	00027	709041	Offset / gain count lower limit for downloading of online module A module replacement
4	00030	h0050	00031	154206	00032	126452	00033	130447	00034	157042	00035	630179	00036	712025	00037	709076	Offset / gain count upper limit for downloading of online module A module replacement
5	00020	h0050	00021	130043	00022	113045	00023	126646	00024	207301	00025	157022	00026	630029	00027	709041	After replacing the B module, offset / gain count lower limit for uploading online module replacement
6	00030	h0050	00031	154206	00032	126452	00033	130447	00034	157042	00035	630179	00036	712025	00037	709076	After replacing the B module, offset / gain count upper limit for uploading online module replacement
7	00040	h0000	00041	130041	00042	113045	00043	126646	00044	207301	00045	157022	00046	630029	00047	709041	After replacing the B module, offset / gain count lower limit for downloading online module replacement
8	00050	h0050	00051	154206	00052	126452	00053	130447	00054	157042	00055	630179	00056	712025	00057	709076	After replacing the B module, offset / gain count upper limit for downloading online module replacement

5. Program examples using user offset and gain setting function by online module change with XGI CPU

5.1 Download program after installed RTD Module at slot no. 7 which finished user offset and gain setting

5.2 If %MX0 set to 1, Read upload offset and gain values of RTD module which already finished user Offset and gain setting.

- Using Array GETE function block, save upload offset and gain values into DATA areas.

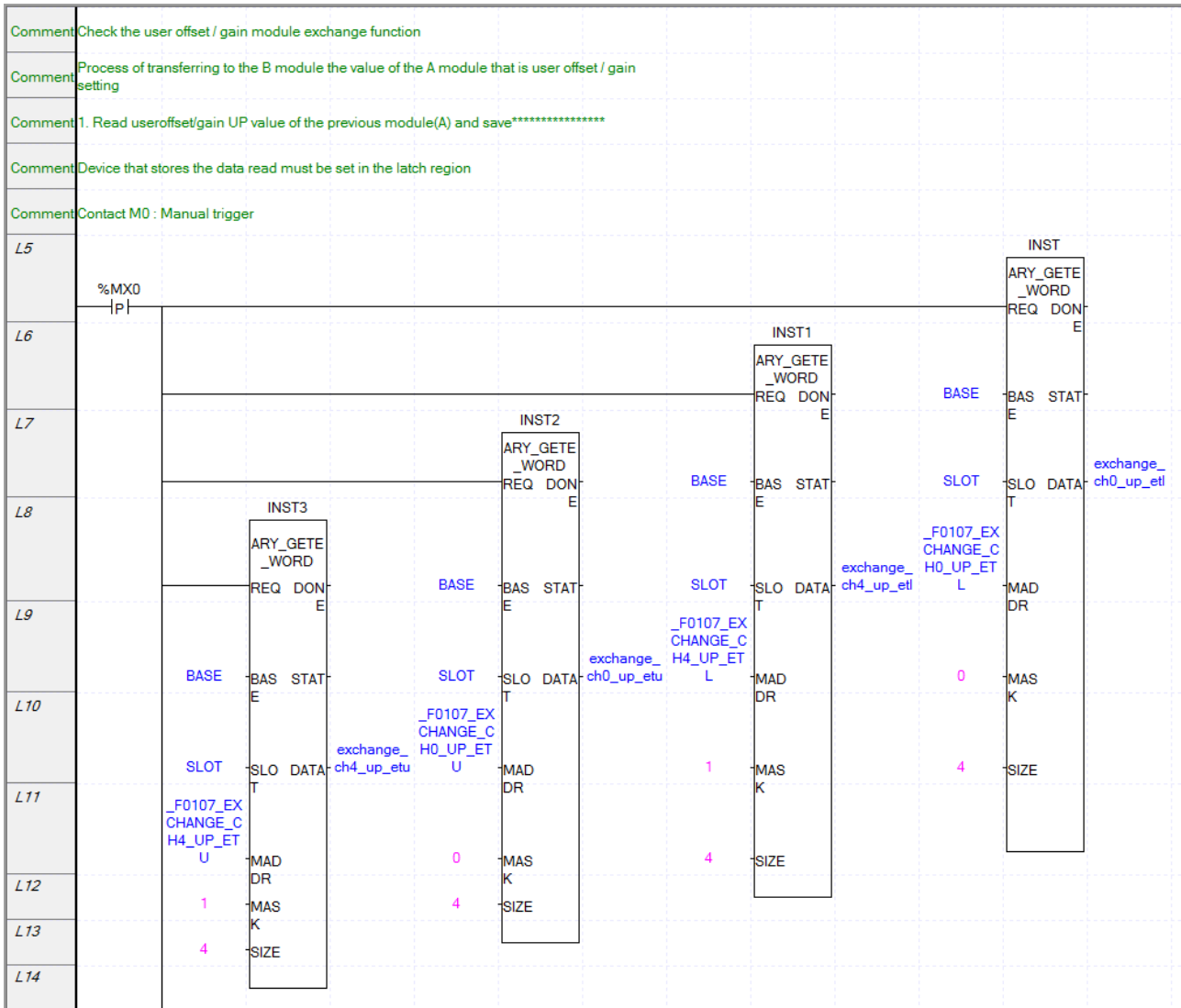

Appendix3 User Offset and Gain Setting Function

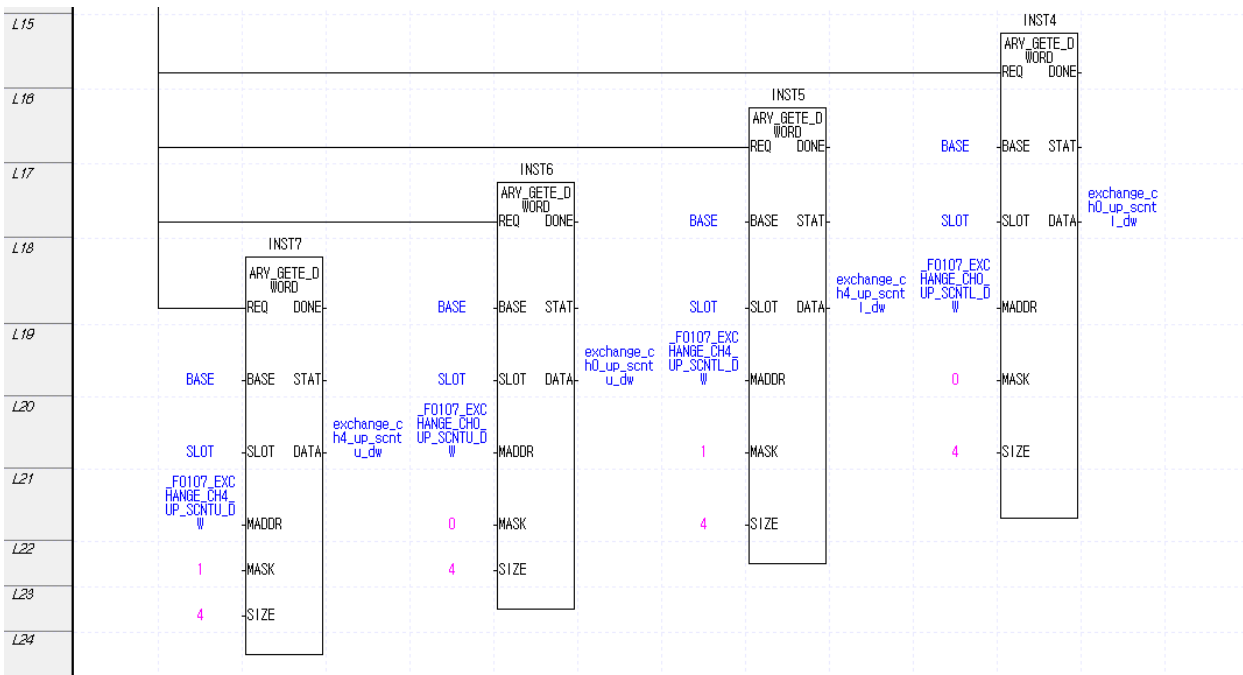

Appendix3 User Offset and Gain Setting Function

5.3 After changing module by Module Changing Wizard on the online window.

Using the user offset and gain setting function by online module change, set to 1 at %MX1 bit to start user offset and gain setting function mode.

If %MX2 set to 1, start to save user offset and gain value and when %MX3 set to 1, read saved data of changed module.

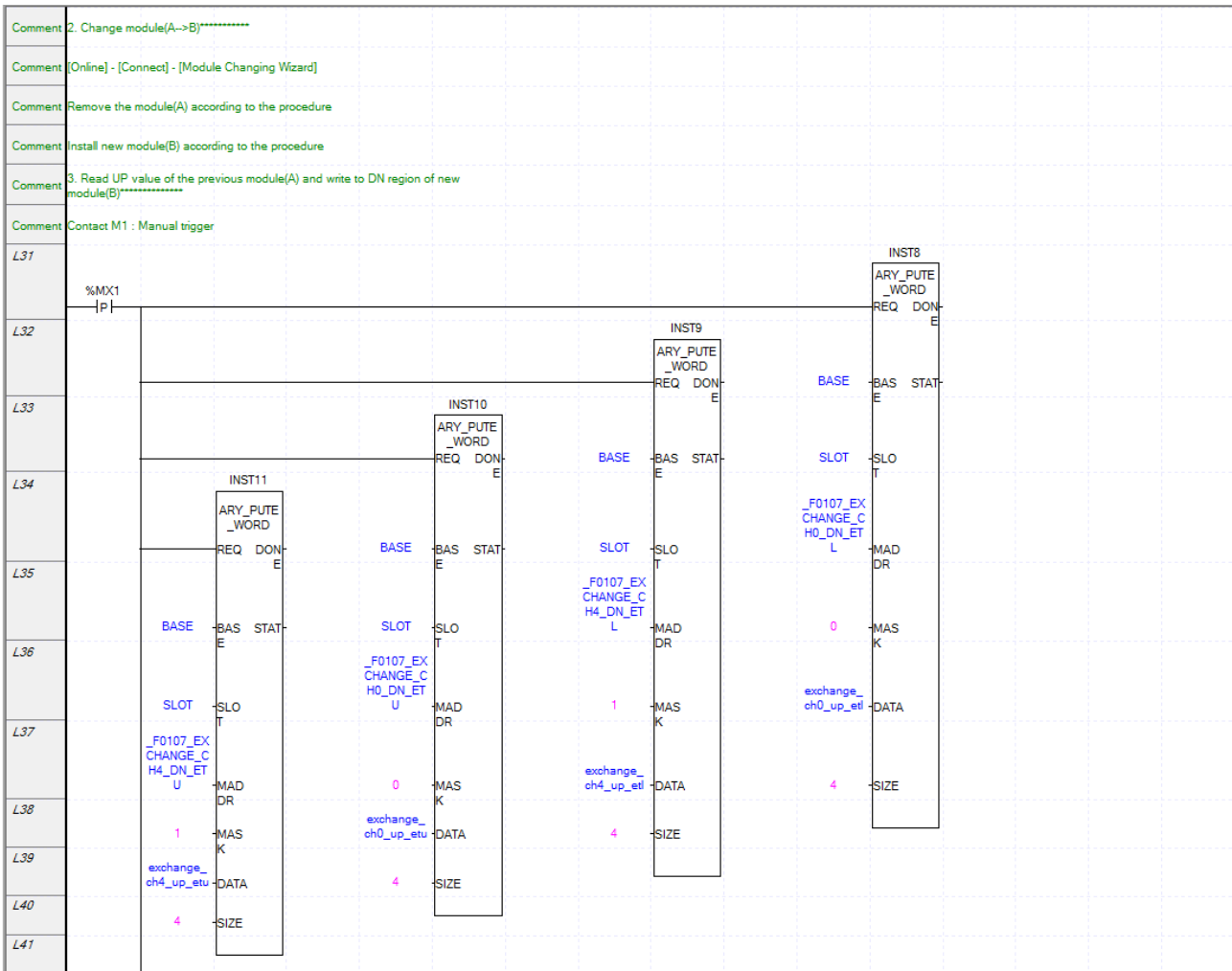

Appendix3 User Offset and Gain Setting Function

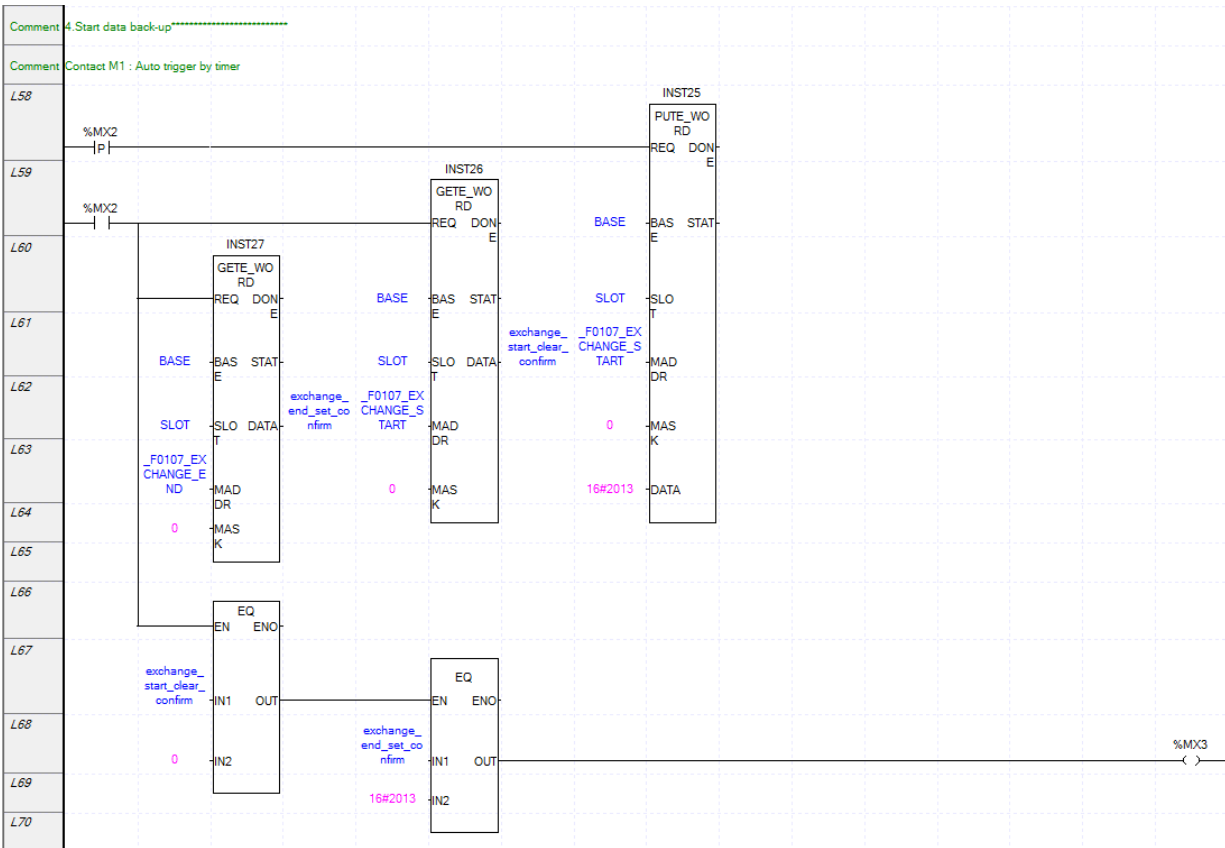
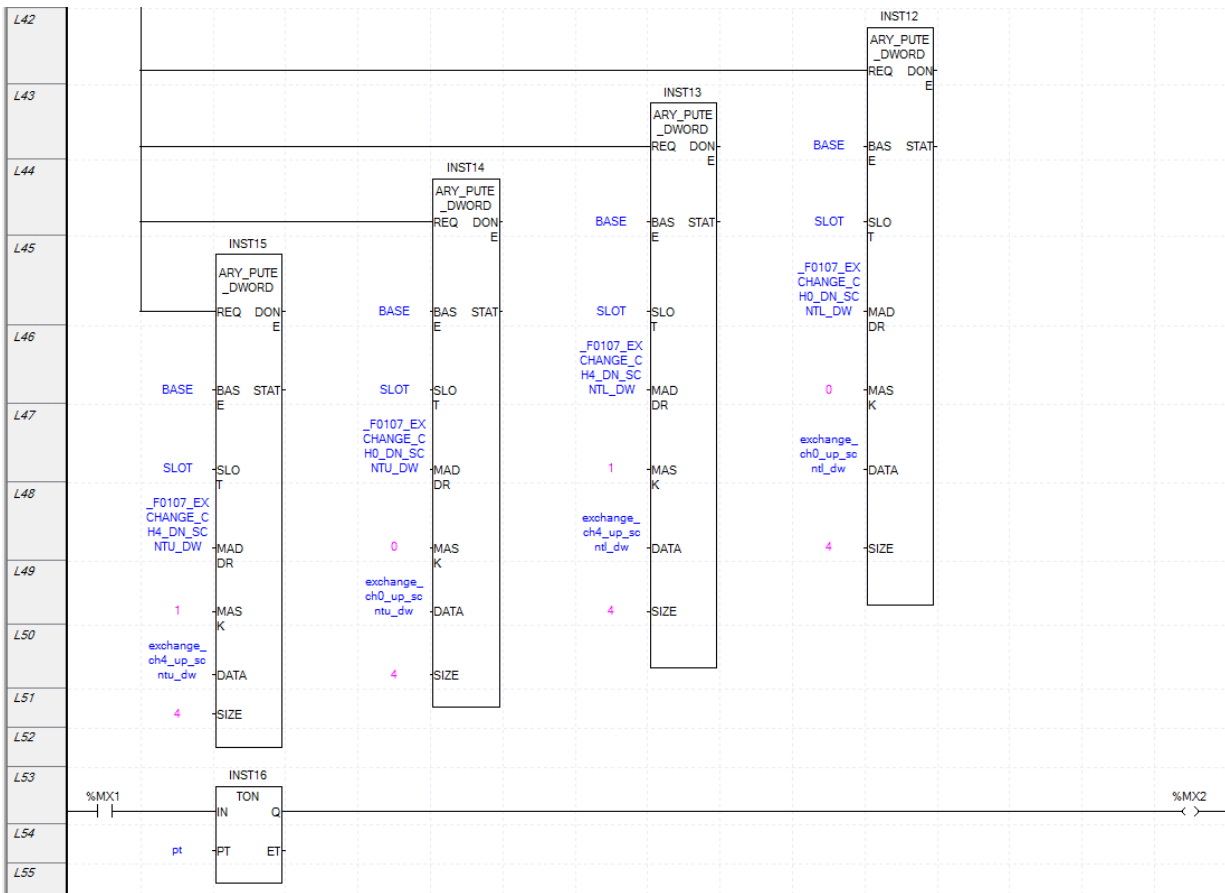

Appendix3 User Offset and Gain Setting Function

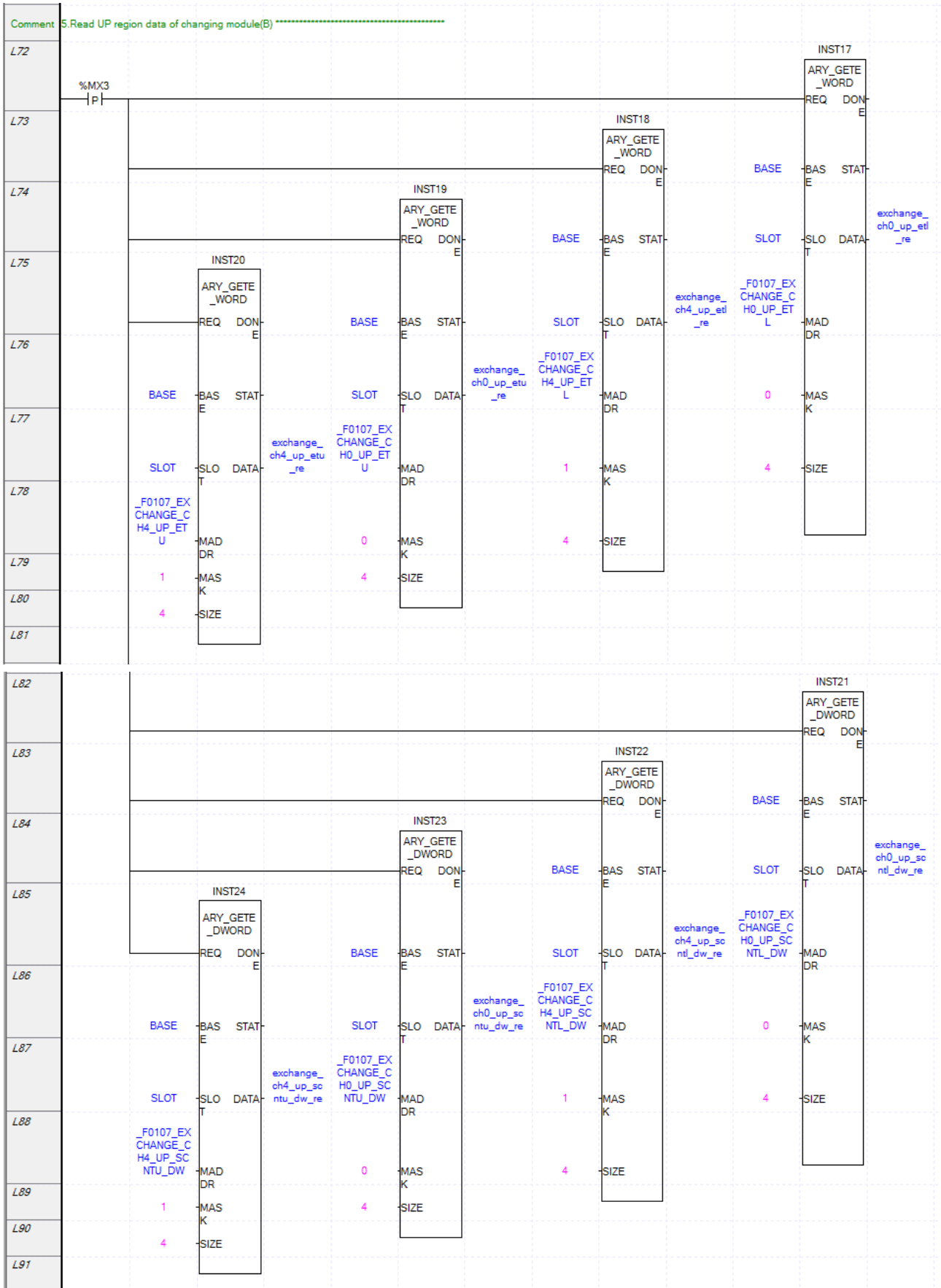

Appendix3 User Offset and Gain Setting Function

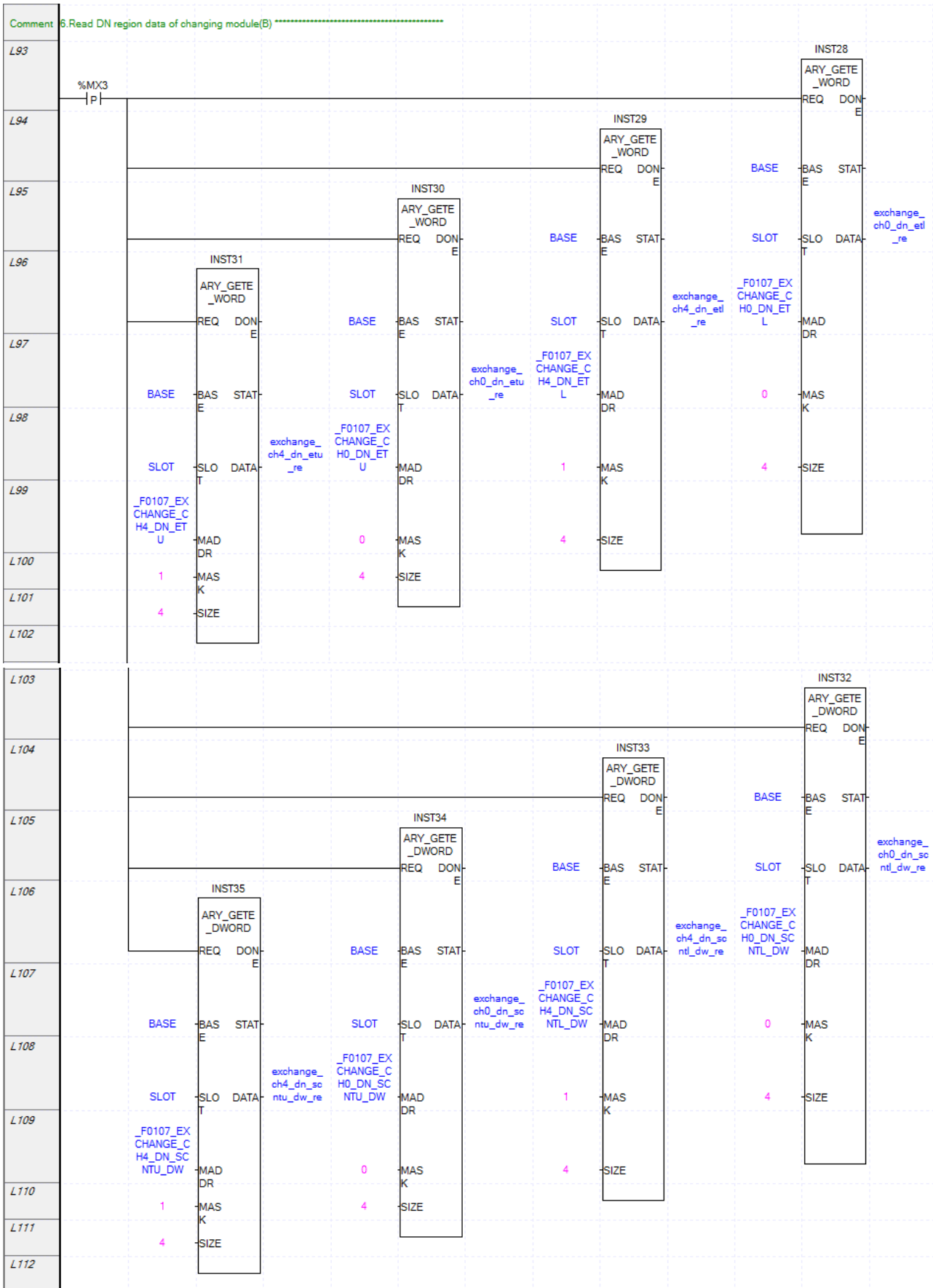

6. Program examples using user offset and gain setting function by online module change with XGR CPU

6.1 There are two ways, module changing wizard and hot swap, by online module change of XGR

In order to hot swap option, select hot swap option on redundancy parameter setting window.

6.2 Download program after installed RTD Module at slot no. 7 which finished user offset and gain setting

6.3 If %MX0 set to 1, Read upload offset and gain values of RTD module which already finished user Offset and gain setting.

- Using Array GETE function block, save upload offset and gain values into DATA areas.

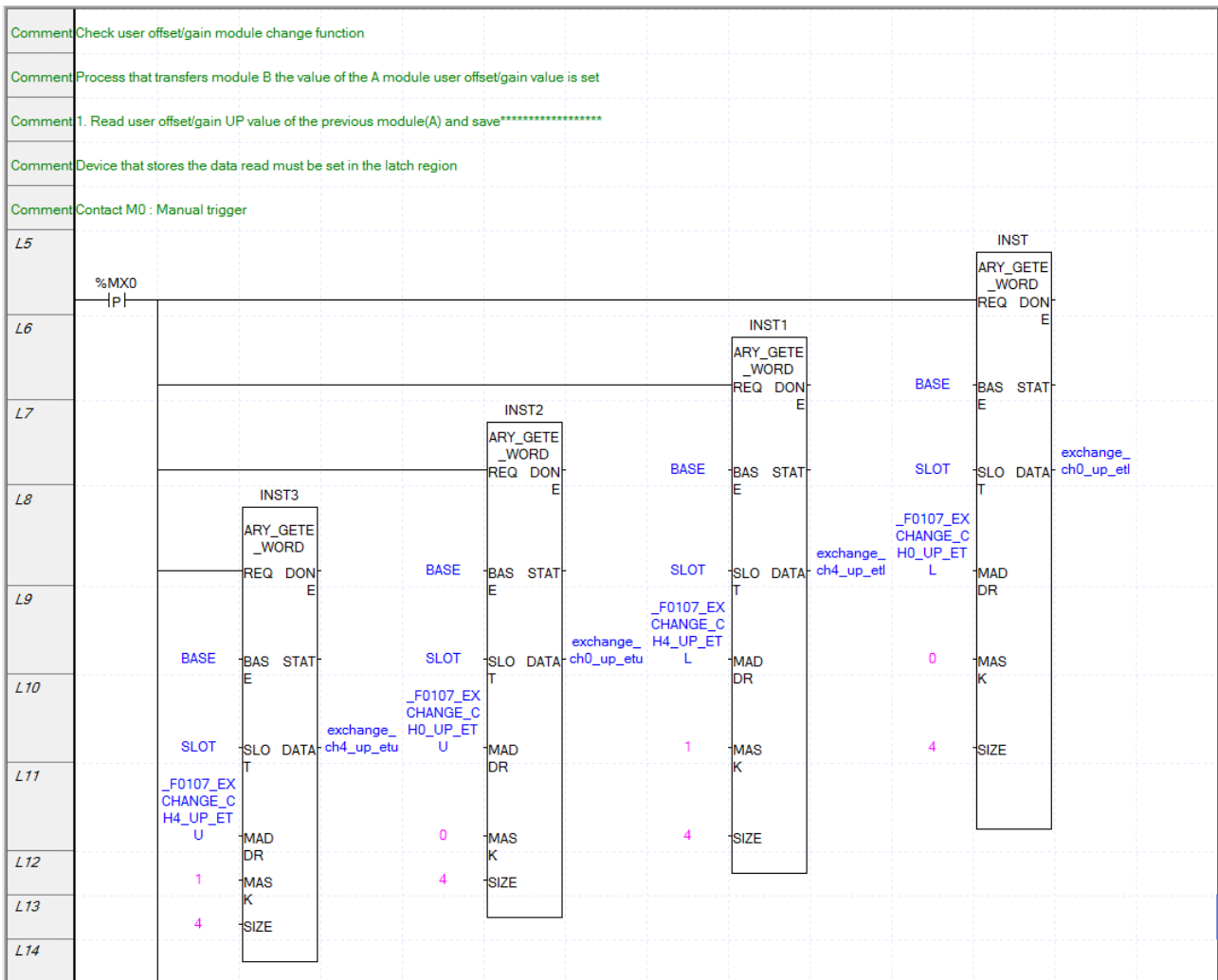

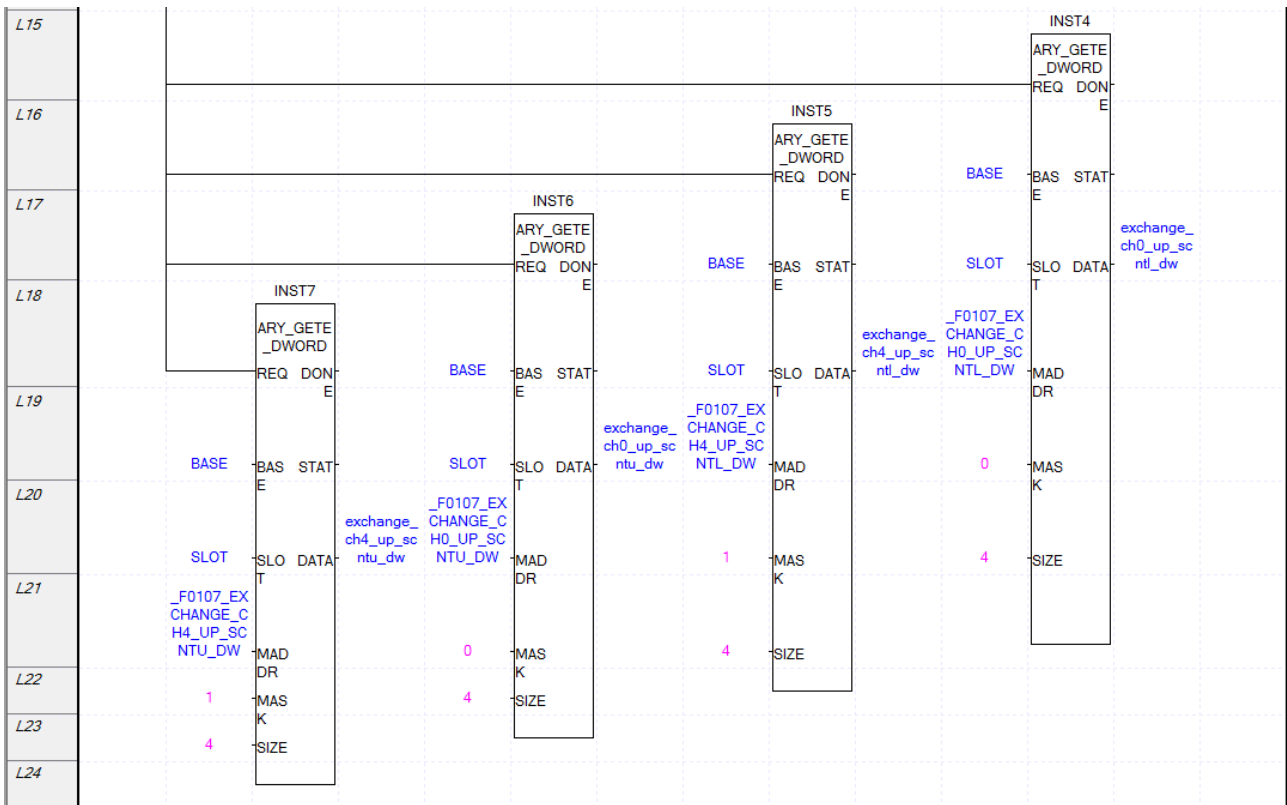

6.4 After changing module by Module Changing Wizard on the online window.

Using the user offset and gain setting function by online module change, set to 1 at %MX1 bit to start user offset and gain setting function mode.

If %MX2 set to 1, start to save user offset and gain value and when %MX3 set to 1, read saved data of changed module.

6.5 In XGR system, when using PUTE command to the same upper and lower address with one contact, PUTE command runs abnormal, So separate contacts of the same upper and lower address each other. At following program, using %MX3 contact and %MX5 contact at the same address.

Appendix3 User Offset and Gain Setting Function

Comment	2. Change module(A->B)*****
Comment	[Online] - [Connect] - [Module Changing Wizard] or use Hot swap function
Comment	Remove the module(A) according to the procedure
Comment	Install new module(B) according to the procedure
Comment	3. Read UP value of the previous module(A) and write to DN region of new module(B)
Comment	Contact M1 : Manual trigger

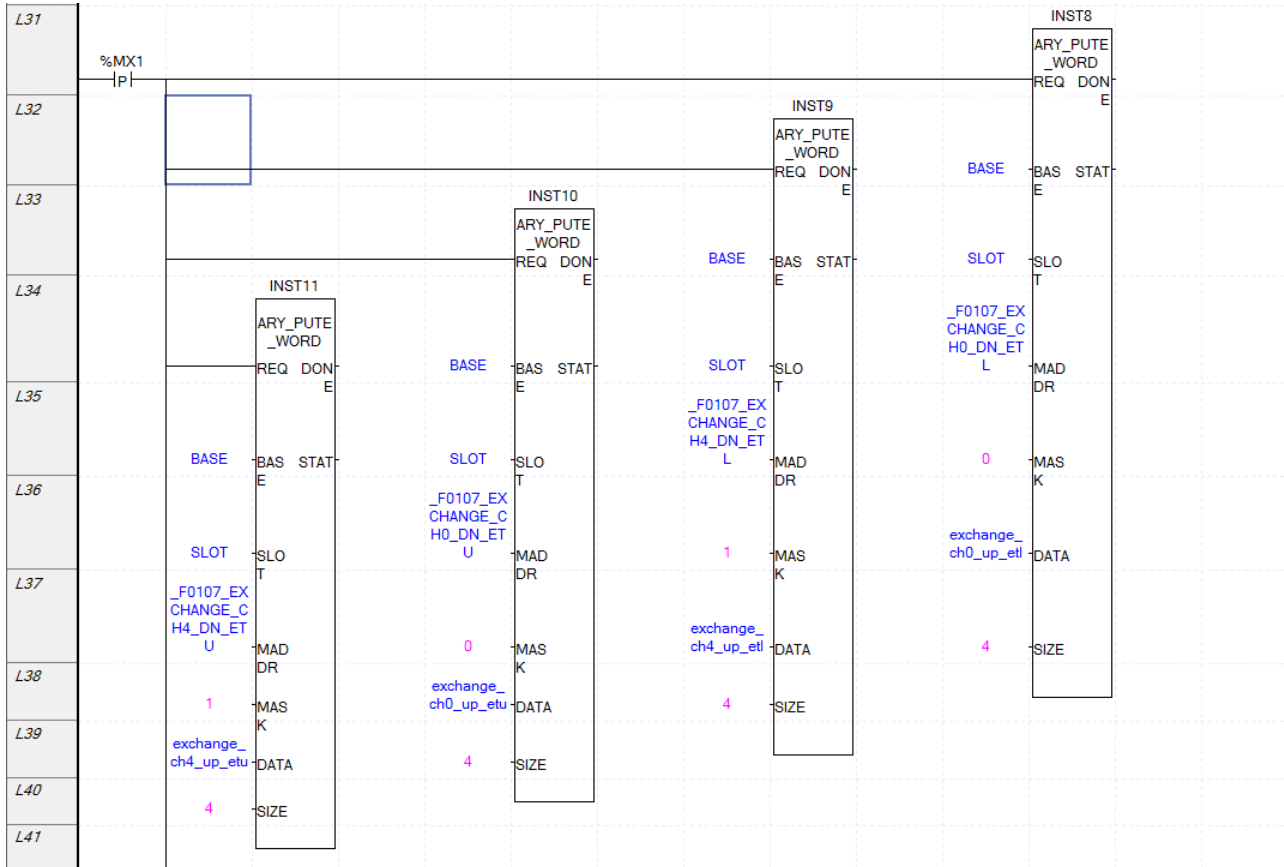

Appendix3 User Offset and Gain Setting Function

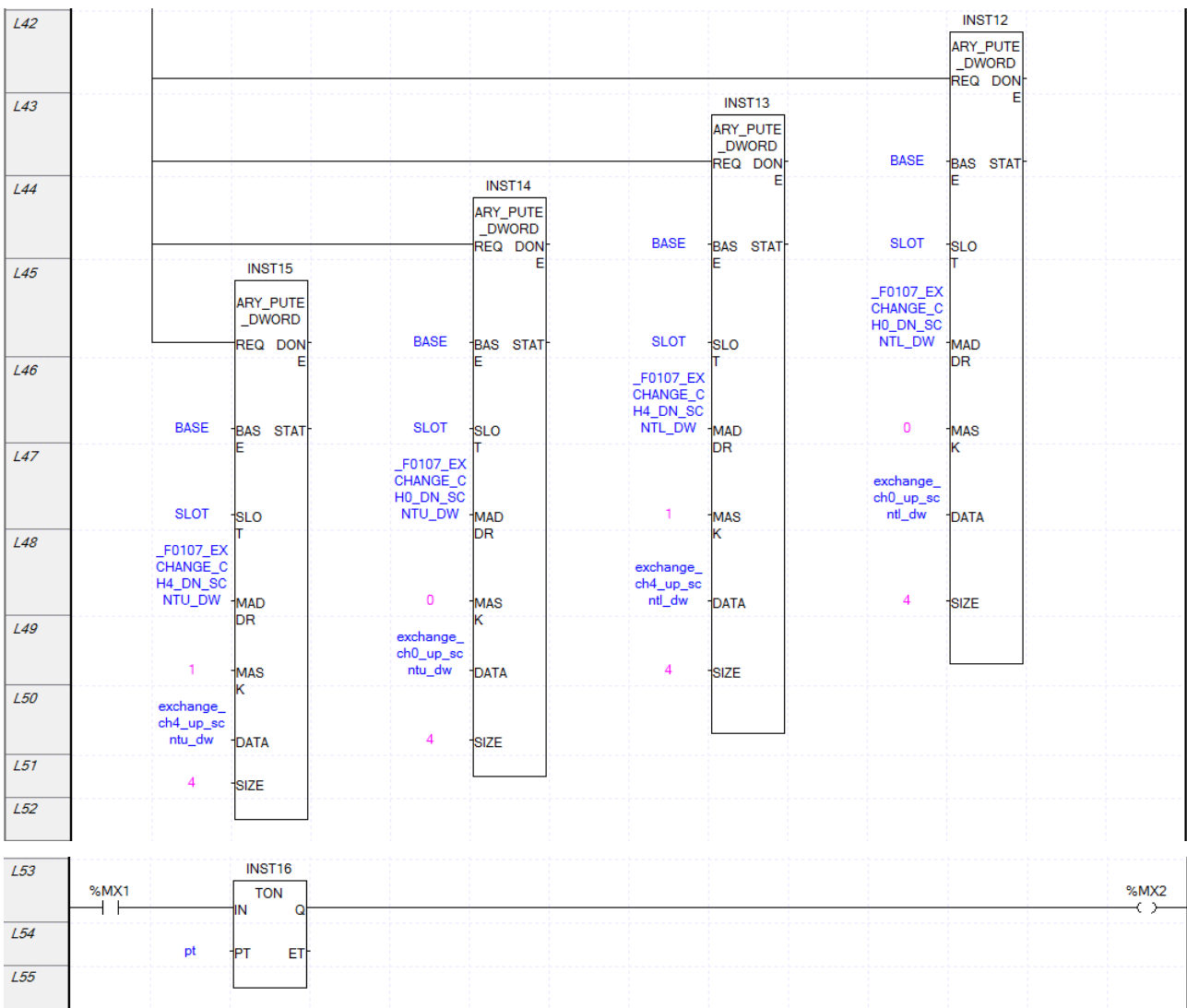

Appendix3 User Offset and Gain Setting Function

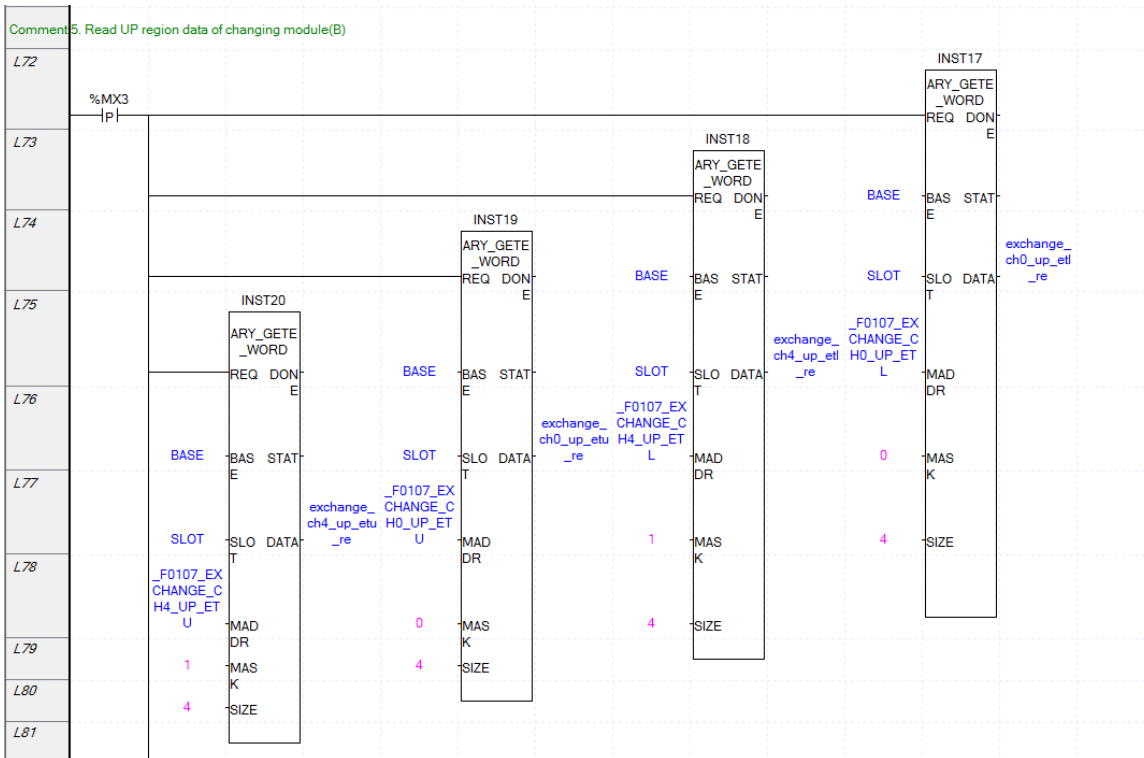
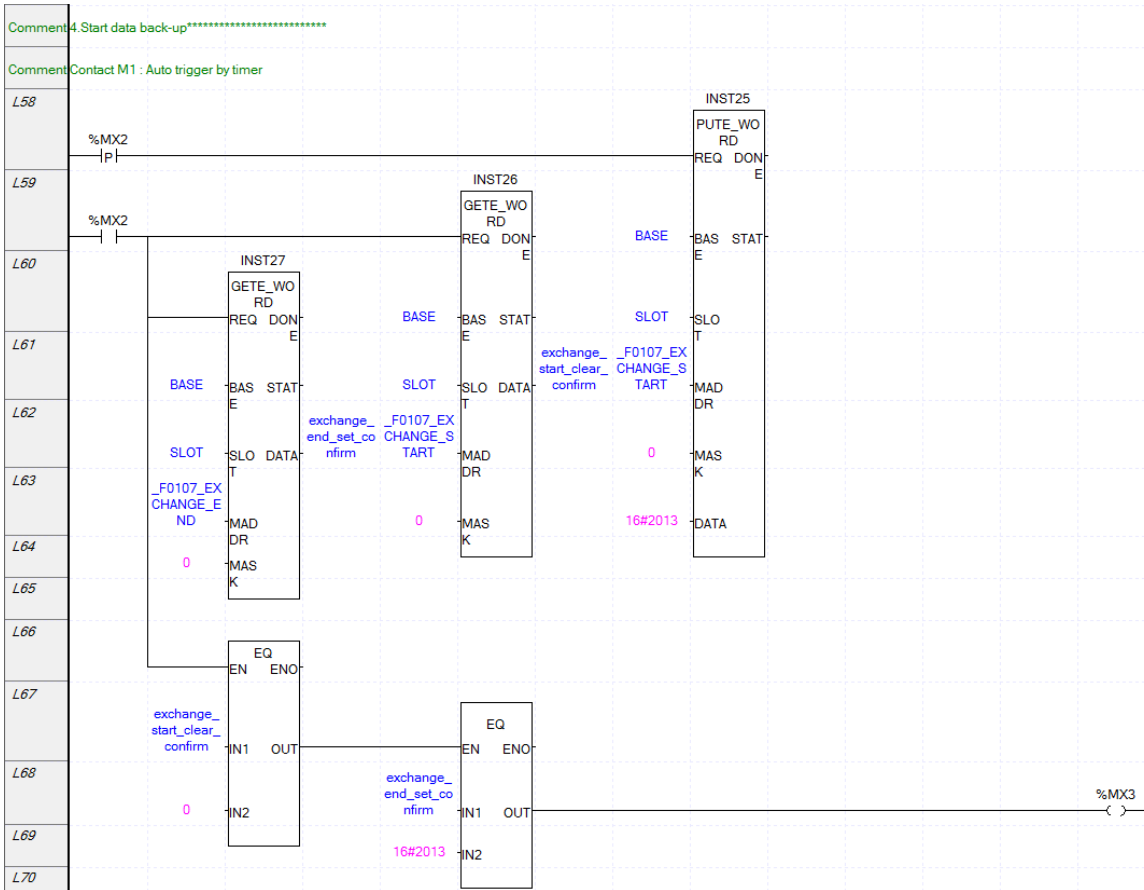

Appendix3 User Offset and Gain Setting Function

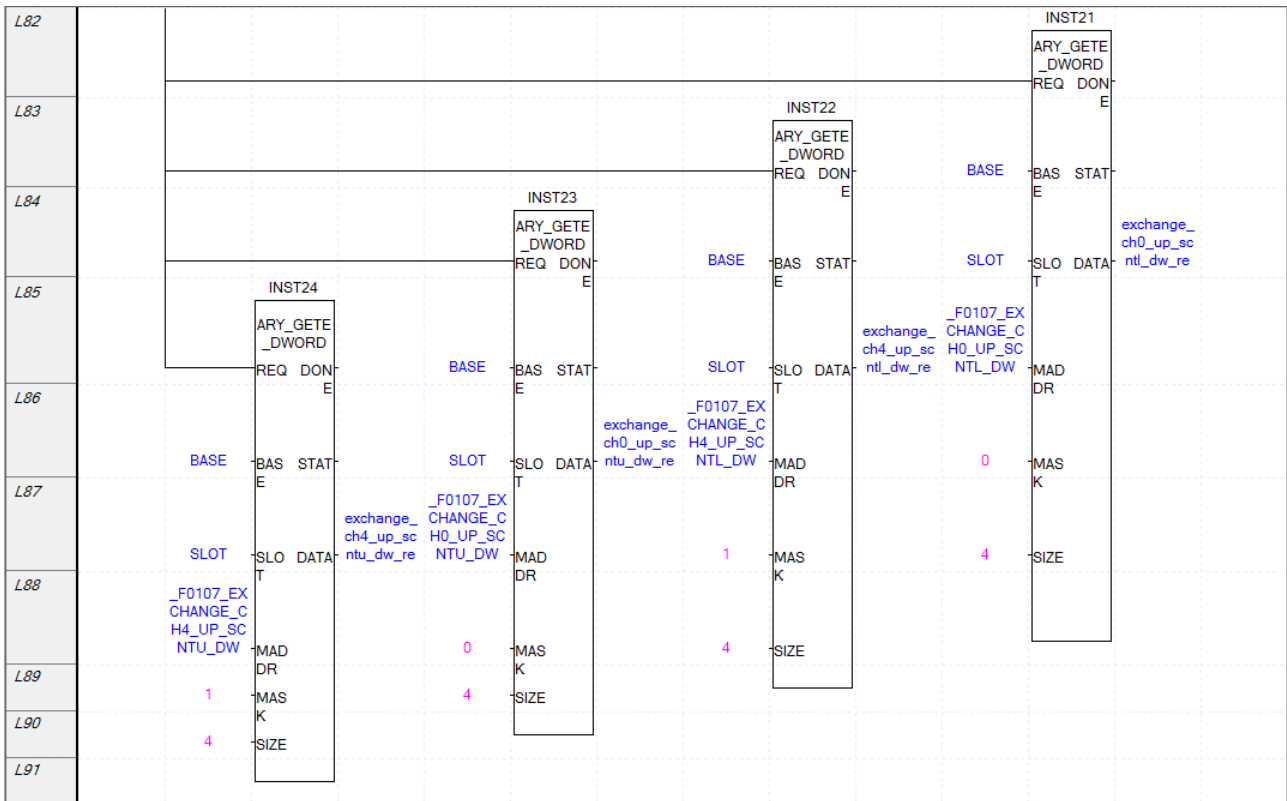

Comment 6. Read DN region data of changing module(B)

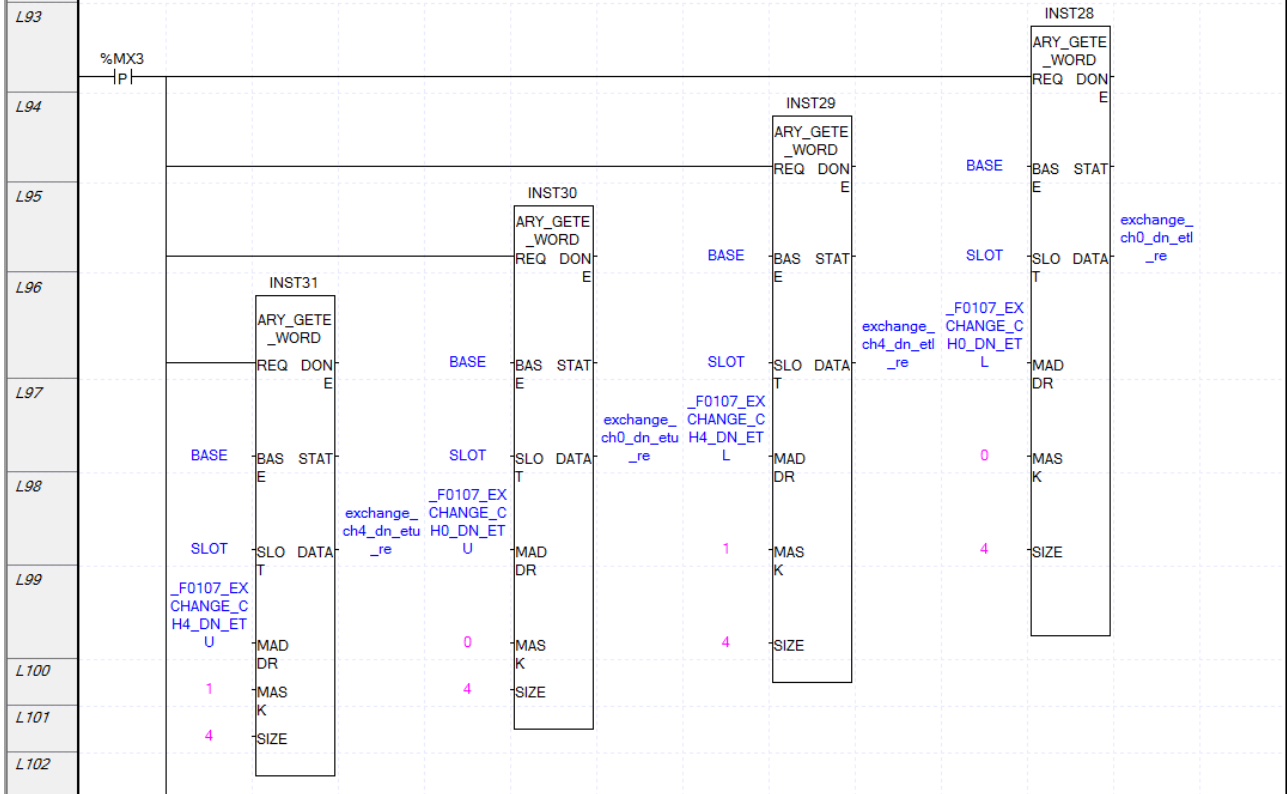

Appendix3 User Offset and Gain Setting Function

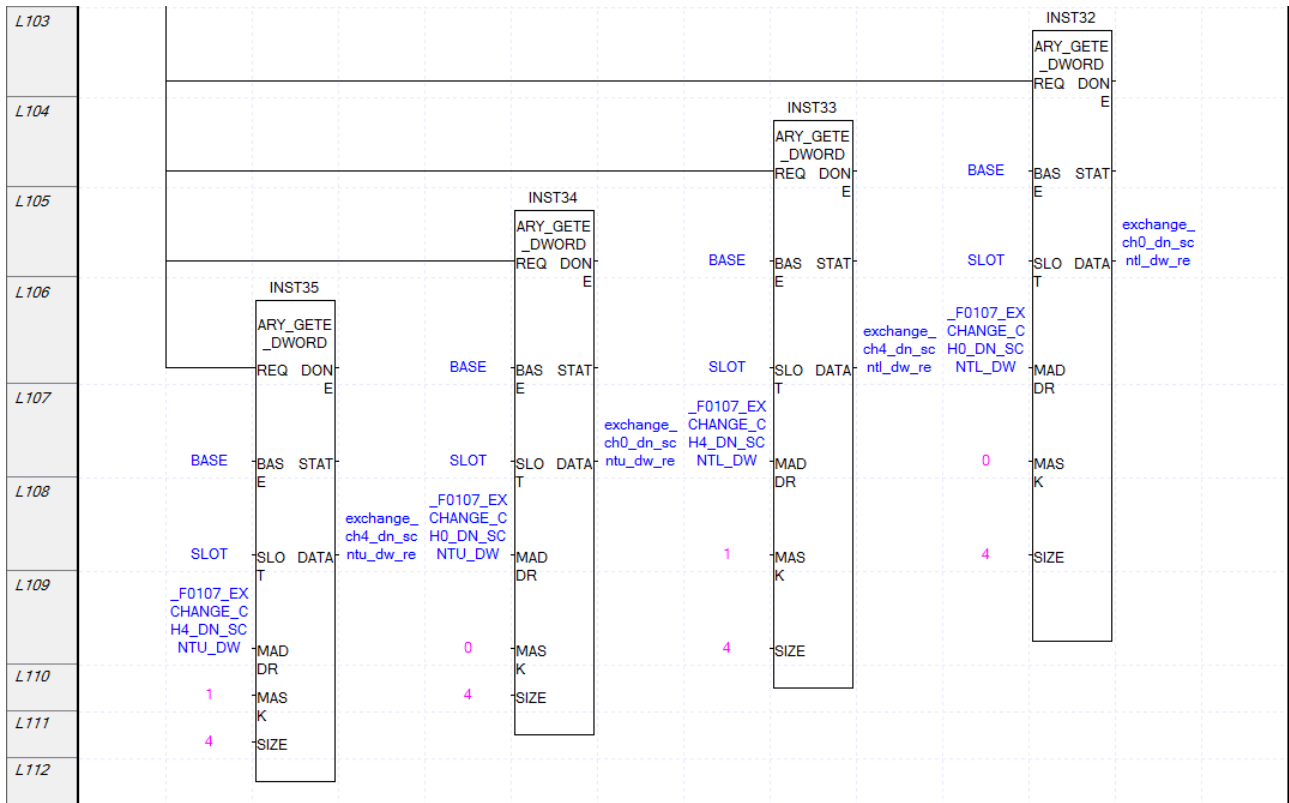

Warranty

1. Warranty Period

The product you purchased will be guaranteed for 18 months from the date of manufacturing.

2. Scope of Warranty

Any trouble or defect occurring for the above-mentioned period will be partially replaced or repaired. However, please note the following cases will be excluded from the scope of warranty.

- (1) Any trouble attributable to unreasonable condition, environment or handling otherwise specified in the manual,
- (2) Any trouble attributable to others' products,
- (3) If the product is modified or repaired in any other place not designated by the company,
- (4) Due to unintended purposes
- (5) Owing to the reasons unexpected at the level of the contemporary science and technology when delivered.
- (6) Not attributable to the company; for instance, natural disasters or fire

3. Since the above warranty is limited to PLC unit only, make sure to use the product considering the safety for system configuration or applications.

Environmental Policy

LS ELECTRIC Co., Ltd supports and observes the environmental policy as below.

Environmental Management

LS ELECTRIC considers the environmental preservation as the preferential management subject and every staff of LS ELECTRIC use the reasonable endeavors for the pleasurable environmental preservation of the earth.

About Disposal

LS ELECTRIC' PLC unit is designed to protect the environment. For the disposal, separate aluminum, iron and synthetic resin (cover) from the product as they are reusable.



www.lselectric.co.kr

LS ELECTRIC Co., Ltd.

■ Headquarter

LS-ro 127(Hogye-dong) Dongan-gu, Anyang-si, Gyeonggi-Do, 14119, Korea

■ Seoul Office

LS Yongsan Tower, 92, Hangang-daero, Yongsan-gu, Seoul, 04386, Korea
Tel: 82-2-2034-4033, 4888, 4703 Fax: 82-2-2034-4588
E-mail: automation@lselectric.co.kr

■ Factory

56, Samseong 4-gil, Mokcheon-eup, Dongnam-gu, Cheonan-si, Chungcheongnam-do, 31226, Korea

■ Overseas Subsidiaries

- **LS ELECTRIC Japan Co., Ltd. (Tokyo, Japan)**
Tel: 81-3-6268-8241 E-Mail: jschuna@lselectric.biz
- **LS ELECTRIC (Dalian) Co., Ltd. (Dalian, China)**
Tel: 86-411-8730-6495 E-Mail: jiheo@lselectric.com.cn
- **LS ELECTRIC (Wuxi) Co., Ltd. (Wuxi, China)**
Tel: 86-510-6851-6666 E-Mail: sblee@lselectric.co.kr
- **LS ELECTRIC Shanghai Office (China)**
Tel: 86-21-5237-9977 E-Mail: tsjun@lselectric.com.cn
- **LS ELECTRIC Vietnam Co., Ltd.**
Tel: 84-93-631-4099 E-Mail: jhchoi4@lselectric.biz (Hanoi)
Tel: 84-28-3823-7890 E-Mail: sjbaik@lselectric.biz (Hochiminh)
- **LS ELECTRIC Middle East FZE (Dubai, U.A.E.)**
Tel: 971-4-886-5360 E-Mail: salesme@lselectric.biz
- **LS ELECTRIC Europe B.V. (Hoofddorf, Netherlands)**
Tel: 31-20-654-1424 E-Mail: europartner@lselectric.biz
- **LS ELECTRIC America Inc. (Chicago, USA)**
Tel: 1-800-891-2941 E-Mail: sales.us@lselectricamerica.com

LS ELECTRIC  Technical Question or After-sales Service
Customer Center - Quick Responsive Service, Excellent technical support
TEL. 82-1644-5481 | www.lselectric.co.kr
Specifications in this instruction manual are subject to change without notice due to continuous products development and improvement.