

# T3 / T4 Series

## Thumbwheel Switch Setting Type Temperature Controller

### ■ Features

- Various size as DIN specifications  
(W48×H48, W48×H96, W72×H72, W96×H96mm)
- Various control output (Relay/SSR drive/current)
- Dual setting for simultaneous control for heater and cooler (T4LP)



**⚠ Please read "Safety Considerations" in the instruction manual before using.**

### ■ Ordering Information

T	3	S	-	B	4	R	P	4	C	-	N	
Item	Digit	Size	Alarm/Sub output <sup>※3</sup>	Control method	Power supply	Control output <sup>※3</sup>	Input type <sup>※4</sup>	Temperature range <sup>※4</sup>	Temperature unit	New <sup>※1</sup>	<b>N</b>	New type
											<b>C</b>	°C
											<b>F</b>	°F
											<b>0</b>	-99 to 199°C, -99.9 to 199.9°C
											<b>1</b>	0 to 99.9°C
											<b>2</b>	0 to 200°C, 0 to 200.0°C
											<b>4</b>	0 to 400°C
											<b>8</b>	0 to 800°C/°F
											<b>A</b>	0 to 999°C
											<b>C</b>	0 to 1200°C
<b>F</b>	600 to 1600°C											
<b>P</b>	DPt100Ω											
<b>J</b>	J(IC)											
<b>K</b>	K(CA)											
<b>R</b>	R(PR)											
<b>R</b>	Relay output											
<b>S</b>	SSR drive output											
<b>C</b>	Current output											
<b>4</b>	100-240VAC 50/60Hz											
<b>B</b>	ON/OFF control, Proportional control											
<b>No-mark</b>	None											
<b>A</b>	Alarm output											
<b>S</b>	Sub output											
<b>P</b>	Dual setting output											
<b>S</b>	DIN W48×H48mm (8-pin plug type) <sup>※2</sup>											
<b>M</b>	DIN W72×H72mm											
<b>H</b>	DIN W48×H96mm											
<b>L</b>	DIN W96×H96mm											
<b>3</b>	999 (3-digit)											
<b>4</b>	9999 (4-digit)											
<b>T</b>	Temperature Controller											

※1: Name plate and connections are different from previous T3/T4 Series.

※2: Sockets (PG-08, PS-08(N)) are sold separately.

※3: Output by Series

Series	T3S	T3H	T3HA	T3HS	T4M	T4MA	T4L	T4LA	T4LP
Control output	●	●	-	-	●	-	●	-	-
Control output+Alarm/Sub output	-	-	●	●	-	●	-	●	-
Dual setting output	-	-	-	-	-	-	-	-	●

# Thumbwheel Switch Setting Type

※4: Input type and temperature range by Series

Input type		Model	Series							
			T3S	T3H	T3HA	T3HS	T4M T4MA	T4L T4LA	T4LP	
Thermocouples	K(CA)	0 to 400°C	4	●	●	●	●	●	●	●
		0 to 800°C	8	●	●	●	-	●	●	●
		0 to 999°C	A	-	●	●	-	-	-	-
		0 to 1200°C	C	-	-	-	-	●	●	●
	J(IC)	0 to 200°C	2	●	-	-	-	-	-	-
		0 to 400°C	4	●	●	●	●	●	●	●
		0 to 800°F	8	-	●	-	-	-	-	-
R(PR)	600 to 1600°C	F	-	-	-	-	●	●	●	
RTD	Dpt 100Ω	-99.9 to 199.9°C	0	-	-	-	-	●	●	-
		-99 to 199°C	0	-	●	●	-	-	-	-
		0 to 99.9°C	1	●	●	-	-	-	-	-
		0 to 200.0°C	2	-	-	-	-	-	-	●
		0 to 200°C	2	●	-	-	-	-	-	-
		0 to 400°C	4	●	●	●	●	●	●	●

※Please contact us for temperature unit °F model.

## Specifications

Series	T3S	T3H	T3HA	T3HS	T4M	T4MA	T4L	T4LA	T4LP
Power supply	100-240VAC~ 50/60Hz								
Allowable voltage range	90 to 110% of rated voltage								
Power consumption	Max. 5VA								
Display method	7-segment (red) LED method								
Character size (W×H)	3.8×7.6mm			6.0×10.0mm			8.0×14.2mm		
Input type	RTD	DPT100Ω (Allowable line resistance max. 5Ω per a wire)							
	TC	K(CA), J(IC)				K(CA), J(IC), R(PR)			
Display accuracy <sup>※1</sup>	RTD	●At room temperature (23°C ± 5°C): (PV ± 0.5% or ± 1°C, select the higher one) ± 1-digit							
	TC	●Out of room temperature range: (PV ± 0.5% or ± 2°C, select the higher one) ± 1-digit							
Control output	Relay	OUT1: 250VAC~ 5A, 30VDC= 5A, 1c, OUT2: 250VAC~ 2A, 30VDC= 2A, 1c <sup>※2</sup>							
	SSR	Max. 12VDC= ±2V 20mA							
	Current	DC4-20mA (resistive load max. 500Ω)							
Alarm/Sub/ Dual setting output	—		250VAC~ 2A 1c		—		250VAC~ 2A 1a		—
Sampling period	100ms								
Control method	ON/OFF, Proportional control								
Hysteresis	F.S. 0.5%		F.S. 0.2 to 3% variable						
Proportional band	F.S. 3%		F.S. 1 to 10% variable						
Proportional cycle	20 sec								
RESET range	F.S. -3 to 3% variable								
Relay life cycle	Mechanical	Over 5,000,000 times							
	Electrical	OUT1: Over 100,000 times, OUT2: Over 200,000 times							
Dielectric strength	2,000VAC 50/60Hz for 1min (between input terminal and power terminal)								
Vibration	0.75mm amplitude at frequency of 10 to 55Hz (for 1 min) in each X, Y, Z direction for 2 hours								
Insulation resistance	Over 100MΩ (at 500VDC megger)								
Noise immunity	Square-wave noise by noise simulator (pulse width 1μs) ±2kV R-phase and S-phase								
Memory retention	Approx. 10 years (when using non-volatile semiconductor memory type)								
Environment	Ambient temperature	-10 to 50°C, Storage: -20 to 60°C							
	Ambient humidity	35 to 85% RH, Storage: 35 to 85% RH							
Weight <sup>※3</sup>	Approx. 135g (approx. 95g)	Approx. 239g (approx. 176g)			Approx. 246g (approx. 180g)		Approx. 310g (approx. 222g)		

※1: In case of the T3S Series and the decimal point display models

At room temperature (23°C±5°C): (PV ±0.5% or ±2°C, select the higher one)±1-digit

Out of room temperature range: (PV ±0.5% or ±3°C, select the higher one)±1-digit

※2: Dual setting output of the T4LP is fixed as relay output and, it is also available as alarm output.

※3: The weight includes packaging. The weight in parenthesis is for unit only.

※Environment resistance is rated at no freezing or condensation.

SENSORS

FIELD INSTRUMENTS

CONTROLLERS

MOTION DEVICES

SOFTWARE

(A) Temperature Controllers

(B) SSRs

(C) Power Controllers

(D) Counters

(E) Timers

(F) Digital Panel Meters

(G) Indicators

(H) Converters

(I) Digital Display Units

(J) Sensor Controllers

(K) Switching Mode Power Supplies

(L) Recorders

(M) HMI's

(N) Industrial PC

(O) Field Network Devices

# T3 / T4 Series

## Unit Description

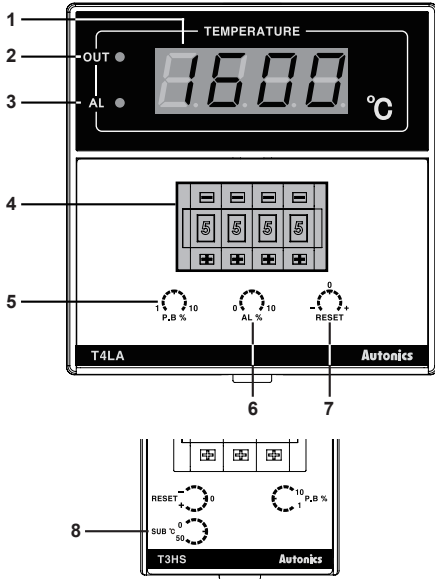

### 1. Present temperature (PV) display

It displays present temperature.

### 2. Control output (OUT) indicator

It turns ON when control output is ON.

※In case of the T3S, the upper DOT of last digit flashes.



### 3. Alarm output (AL) indicator

It turns ON when alarm output is ON. (only for alarm output model)

In case of the sub output model (T3HS), the sub (SUB) indicator turns ON when sub output is ON.

### 4. Set value (SV) thumbwheel switch

Switch for setting temperature.

(-) button: Decreases number, (+) button: Increases number

If the setting is out of the temperature range of temperature sensor, the present temperature (PV) display part flashes 5.u.E.r and the present value in turn.

※The models which temperature range is 0 (-99.9 to 199.9°C, -99 to 199°C) of temperature sensor DPT100Ω are only set 1↔0↔(-).

※The dual setting output model (T4LP) has two thumbwheel switches.

LO SET

(low set output)

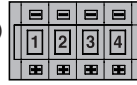

HI SET

(high set output)

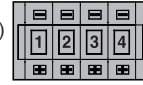

LO SET (low set output) heating control, HI SET (high set output): cooling control

### 5. Hysteresis/Proportional width volume switch (except T3S)

ON/OFF control: Setting for hysteresis. [Setting range] F.S. 0.2 to 3% (For T3S, F.S. 0.5% fixed)

Proportional control: Setting for proportional width. [Setting range] F.S. 1 to 10% (For T3S, F.S. 3% fixed)

Proportional cycle: 20 sec fixed

### 6. Alarm output value volume switch (only for alarm output model)

It sets alarm output value. [Setting range] F.S. 0 to 10%

### 7. RESET volume switch

In case of proportional control, it sets offset. [Setting range] F.S. -3 to 3%

### 8. Temperature setting of sub output volume switch (only for T3HS)

It sets temperature of the sub output. This output operates as deviation low-limit alarm based on the set sub-output temperature (SV). Setting range: 0 to 50°C

## Connections

※Use terminals of size specified below.

	<Round>	<Forked>
a	Min. 3.5mm	Min. 3.5mm
b	Max. 7.2mm	Max. 7.2mm

### ● T3S

SSR OUT: 12VDC±2V  
20mA Max.  
CURRENT OUT: DC4-20mA  
Load 500Ω Max.

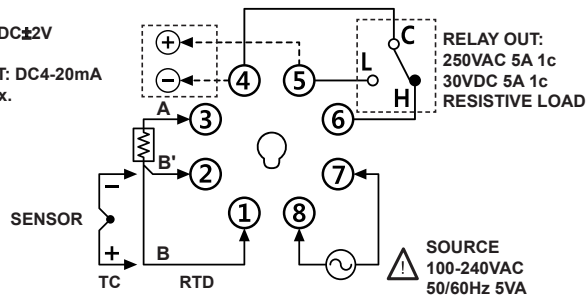

# Thumbwheel Switch Setting Type

## ● T4M/T4MA

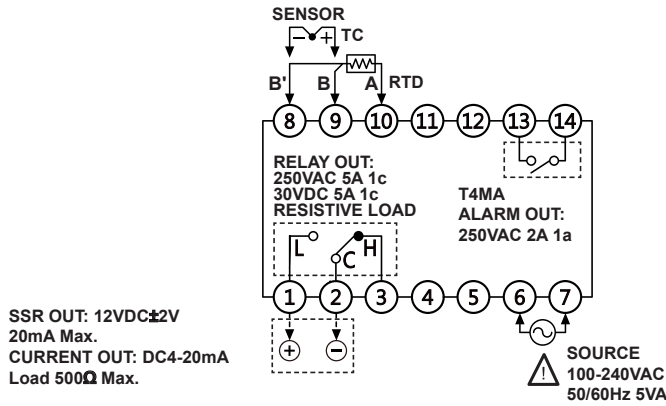

## ● T3H/T3HA/T3HS

SSR OUT: 12VDC $\pm$ 2V  
20mA Max.  
CURRENT OUT: DC4-20mA  
Load 500 $\Omega$  Max.

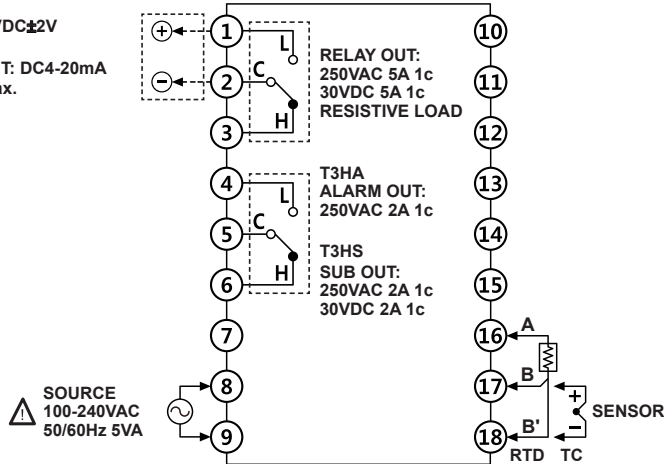

## ● T4L/T4LA/T4LP

SSR OUT: 12VDC $\pm$ 2V  
20mA Max.  
CURRENT OUT: DC4-20mA  
Load 500 $\Omega$  Max.

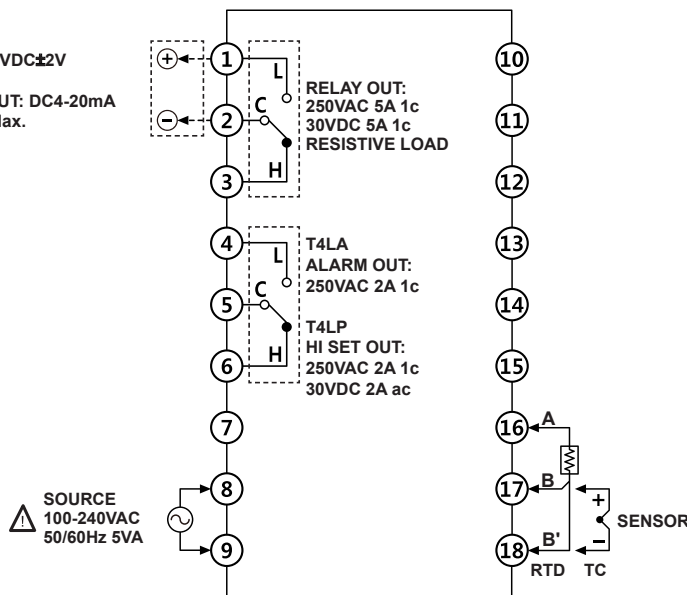

SENSORS
FIELD INSTRUMENTS
CONTROLLERS
MOTION DEVICES
SOFTWARE

(A) Temperature Controllers
(B) SSRs
(C) Power Controllers
(D) Counters
(E) Timers
(F) Digital Panel Meters
(G) Indicators
(H) Converters
(I) Digital Display Units
(J) Sensor Controllers
(K) Switching Mode Power Supplies
(L) Recorders
(M) HMIs
(N) Industrial PC
(O) Field Network Devices

# T3 / T4 Series

## ■ Dimensions

(unit: mm)

### ● T3S

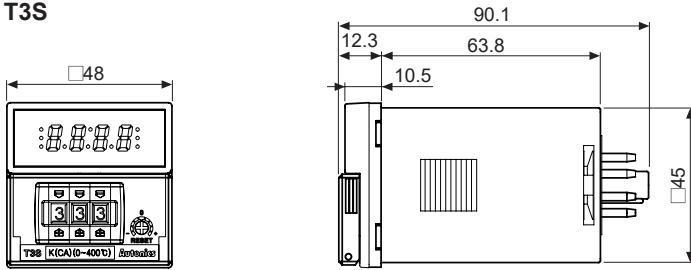

### ● T3H

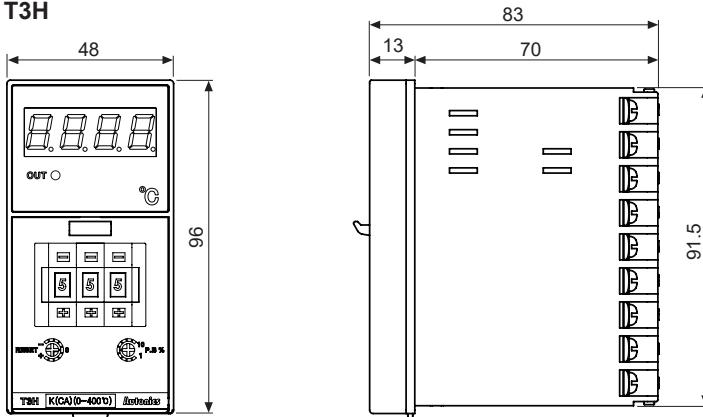

※T3HA, alarm output model, has the alarm output value volume switch.  
 ※T3HS, sub output model, has the temperature setting of sub output volume switch.

### ● T4M

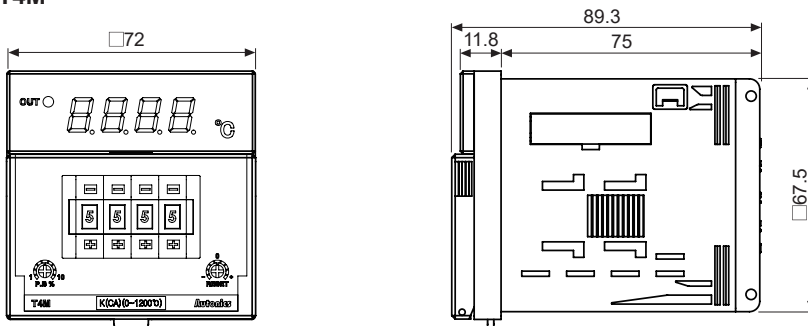

※T4MA, alarm output model, has the alarm output value volume switch.

### ● T4L

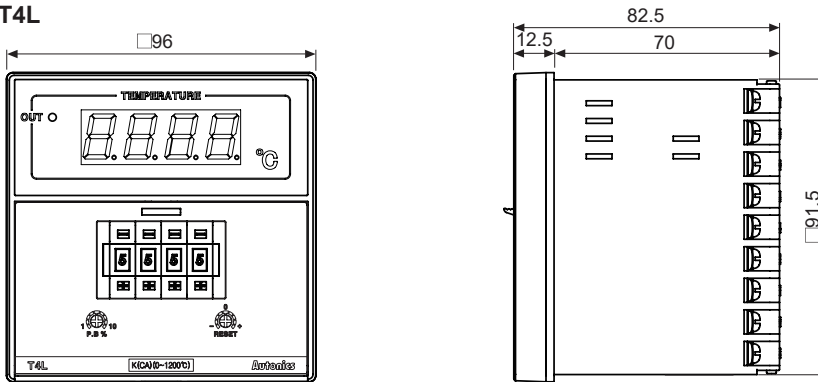

※T4LA, alarm output model, has the alarm output value volume switch.  
 ※T4LP, dual setting output model, has the two thumbwheel switches.

# Thumbwheel Switch Setting Type

## ● Bracket

### ●T3S

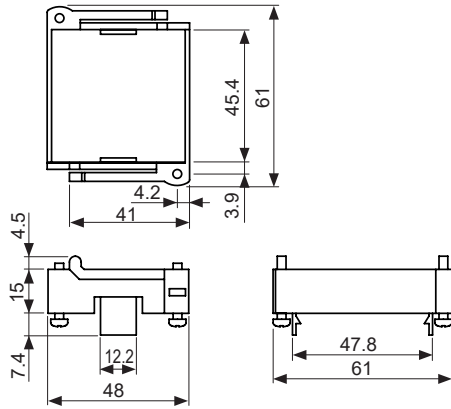

### ●T3H/T4M/T4L

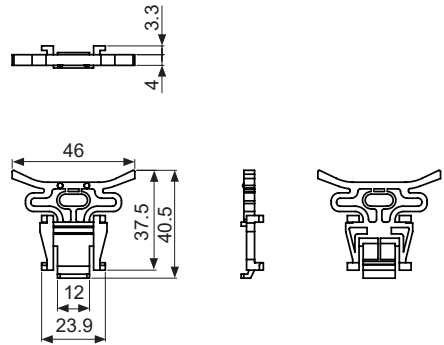

## ● Terminal cover (sold separately)

### ●RMA-COVER (72×72mm)

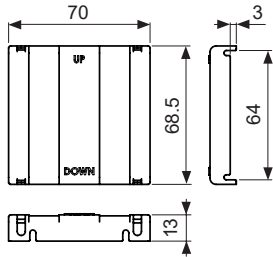

### ●RLA-COVER (96×96mm)

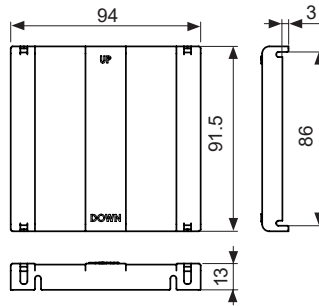

### ●RHA-COVER (48×96mm)

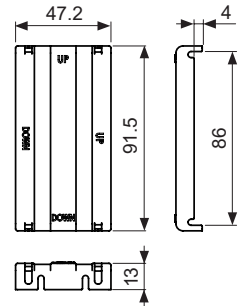

## ● Panel cut-out

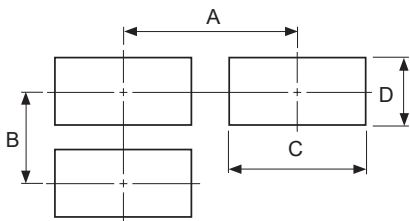

Series	Size	A	B	C	D
T3S		Min. 65	Min. 65	45 <sup>+0.6</sup> <sub>0</sub>	45 <sup>+0.6</sup> <sub>0</sub>
T3H		Min. 65	Min. 115	45 <sup>+0.6</sup> <sub>0</sub>	92 <sup>+0.8</sup> <sub>0</sub>
T4M		Min. 90	Min. 90	68 <sup>+0.7</sup> <sub>0</sub>	68 <sup>+0.7</sup> <sub>0</sub>
T4L		Min. 115	Min. 115	92 <sup>+0.8</sup> <sub>0</sub>	92 <sup>+0.8</sup> <sub>0</sub>

SENSORS
FIELD INSTRUMENTS
<b>CONTROLLERS</b>
MOTION DEVICES
SOFTWARE
(A) Temperature Controllers
(B) SSRs
(C) Power Controllers
(D) Counters
(E) Timers
(F) Digital Panel Meters
(G) Indicators
(H) Converters
(I) Digital Display Units
(J) Sensor Controllers
(K) Switching Mode Power Supplies
(L) Recorders
(M) HMIs
(N) Industrial PC
(O) Field Network Devices

# T3 / T4 Series

## Function

### 1. Control method

#### 1) ON/OFF control

Comparing the present measured temperature and the set temperature, the temperature controller turns ON/OFF of the load power. Interval between ON and OFF of control output is set by the set hysteresis. When hysteresis of control output is too narrow, hunting (overshoot, chattering) may occur by external noise.

[Setting range of Hysteresis] F.S. 0.2 to 3%  
(In case of T3S, F.S. 0.5% fixed)

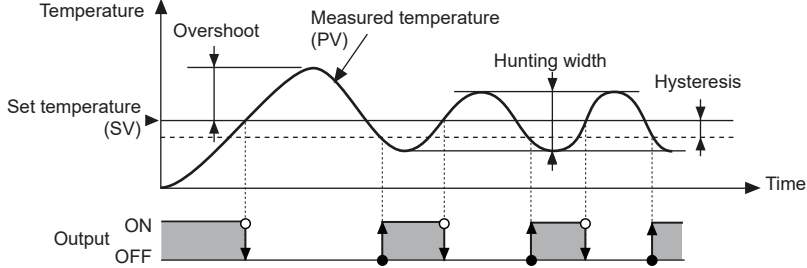

※Control method setting switch

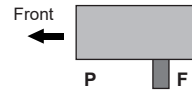

#### 2) Proportional control

Proportional control has control output which is proportional to deviation from the present temperature to the set temperature in the proportional band to the set temperature.

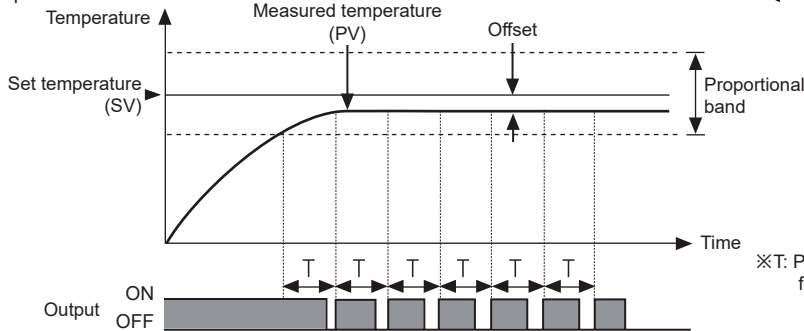

※Control method setting switch

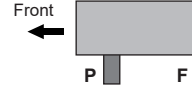

※T: Proportional band is fixed as 20 sec.

It is available to control without overshoot or hunting comparing ON/OFF control but it may cause offset. Correct the offset with the RESET volume switch.

[Setting range of Proportional band] F.S. 1 to 10% (In case of T3S, F.S. 3% fixed)

[Setting range of RESET] F.S. -3 to 3%

### 2. Alarm output

Alarm temperature is applied to the high/low-limit based on the set temperature. Alarm output operates deviation high/low-limit.

Setting range of Alarm temperature: F.S. 0 to 10%

E.g.) When F.S. is 400°C and max. alarm temperature (F.S. 10%) is 40°C.

When the set temperature is set as 100°C, alarm output operation range is 140°C to 60°C.

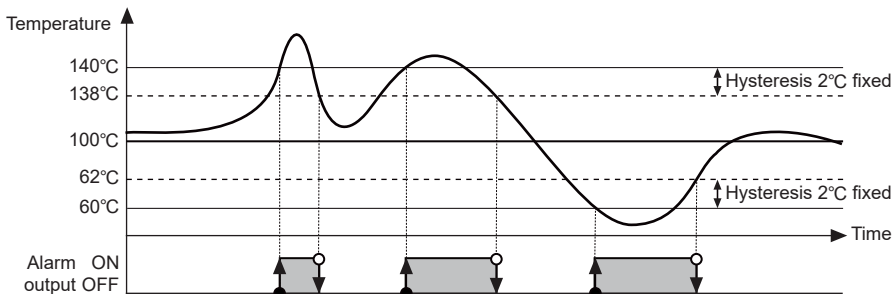

# Thumbwheel Switch Setting Type

## 3. Sub output (Only for T3HS)

Only the T3HS model has sub output. This output operates as deviation low-limit alarm.  
 [Setting range of Sub output]: 0 to 50°C  
 E.g.) Set temperature is set as 100°C and sub-output is set as 20°C

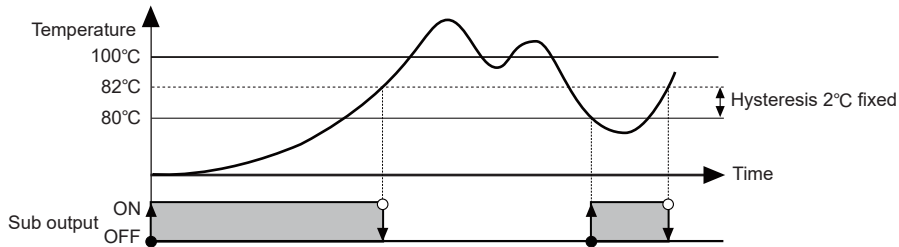

## 4. Dual setting output (Only for T4LP)

Only the T4LP model has dual setting output.  
 -LO SET (low set output: ON/OFF control (Hysteresis: F.S. 0.2 to 3%),  
 Proportional control (Proportional band: F.S. 1 to 10%)  
 -HI SET (high set output): Absolute value high-limit alarm output (Hysteresis: 2°C fixed)  
 E.g.) T4LP, temperature sensor: DPT100, temperature range: 0 to 400°C

Type	Set temperature	Output	Hysteresis
LO SET (low set output)	80°C	ON/OFF control	0.5% (400×0.5%=2°C)
HI SET (High set output)	120°C	Absolute value high-limit alarm output	2°C (fixed)

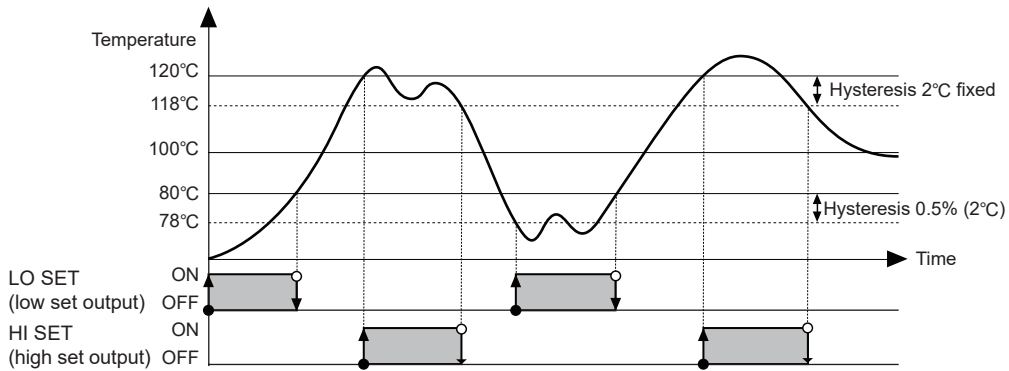

## ■ Display When Power Is ON

When power is supplied, whole display parts turn ON for 1 sec. It displays model type (digits, size, alarm/sub output and control output, sensor, temp. range, unit). Afterward, it returns to RUN mode.

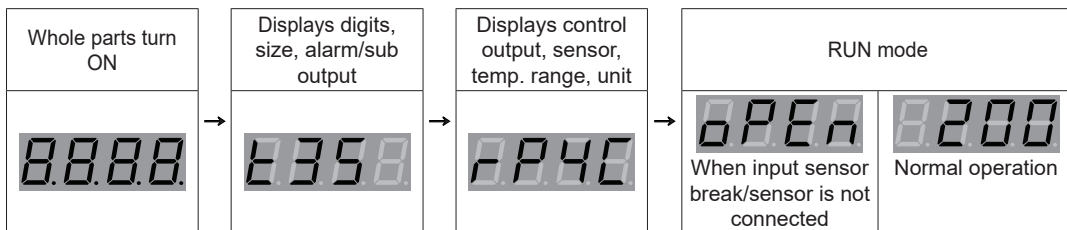

When input sensor break/sensor is not connected, it displays [0PE n]. In case of normal operation, it displays the present input temperature and controls temperature.

※During displaying model type, control output does not operate.

SENSORS
FIELD INSTRUMENTS
CONTROLLERS
MOTION DEVICES
SOFTWARE
(A) Temperature Controllers
(B) SSRs
(C) Power Controllers
(D) Counters
(E) Timers
(F) Digital Panel Meters
(G) Indicators
(H) Converters
(I) Digital Display Units
(J) Sensor Controllers
(K) Switching Mode Power Supplies
(L) Recorders
(M) HMIs
(N) Industrial PC
(O) Field Network Devices



# T3 / T4 Series

## ■ Control Method (ON/OFF, Proportional Control) Setting

Before supplying power, remove the case and set the control method by the control method setting switch.

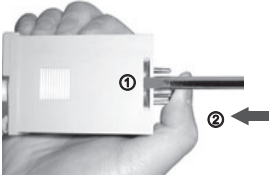
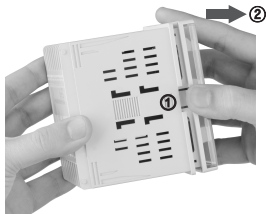
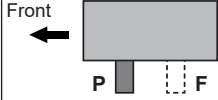
T3S	Other Series	Control method setting switch
 <p>Press the 8-pin plug with your thumb. Insert a flat head driver to the ① groove and uplift the case (same as the other side). Push it to the ② direction and the case is removed.</p>	 <p>Press the ① with your thumb. Pull the case to the ② direction and it is removed.</p>	 <p>P: Proportional control (default) F: ON/OFF control</p>

## ■ Error Display and Output Operation

●: ON  
○: OFF

Display	Description	Control output <sup>※1</sup>	Alarm output	Sub output	Dual output	Troubleshooting
$\alpha P E n$	Flashes when a temperature sensor is broken or not connected.	○	●	○	●	Check the status of the temperature sensor. When the sensor is connected correctly, it is clear.  When the measured temperature is within the temperature range of the sensor, it is clear.
$H H H H$	Flashes when the measured input value is higher than the temperature range of the sensor.	○	●	○	●	
$L L L L$	Flashes when the measured input value is lower than the temperature range of the sensor.	●	●	●	○	
$S u E r$ <sup>※2</sup>	Flashes with the present value when the set value is out of the temperature range of the sensor.	○	○	○	○	The set value should be within the temperature range of the sensor.

※1: T4LP (Dual setting output) is the single output.

※2: When  $S u E r$  and  $\alpha P E n / H H H H / L L L L$  occur at the same time,  $S u E r$  and  $\alpha P E n / H H H H / L L L L$  flash in turn and all output turns OFF.