

③ Spiral Pointed Tap Series for through hole

| Overall length | Thread length | Thread + Neck length | Shank length | Shank dia. | Size of square | Length of square |
|----------------|---------------|----------------------|--------------|------------|----------------|------------------|
| L | ℓ | ℓn | ℓs | Ds | K | ℓk |

JIS

① Spiral Fluted Taps (for blind hole)

② Spiral Fluted Taps (for through hole)

③ Spiral Pointed Taps (for through hole)

④ Hand Taps

⑤ Cemented Carbide Taps

⑥ Roll Taps

⑦ Special Thread Taps Simple inspection tools

⑧ Pipe Taps

⑨ Thread Mills

⑩ Dies

⑪ Center Drills Centering Tools

JIS

SU+PO/SU-PO



Spiral Pointed Taps for Stainless Steels

Specification



• Product Name and Size.

| | |
|-------|-------------------|
| SU+PO | ~ M2.6 |
| SU-PO | M3~, all U, all W |

Recommended Tapping Speeds depending on Materials

| | | | | |
|---------------------------|------------------------------|----------------------------|---------------------|------------------------------------|
| Low carbon steels 低炭素鋼 | Medium carbon steels 中炭素鋼 | High carbon steels 高炭素鋼 | Alloy steels 合金鋼 | Stainless steels ステンレス鋼 |
| ~10 (m/min) | ~10 (m/min) | ~10 (m/min) | ~10 (m/min) | ~10 (m/min) |

For icon explanation, refer to icon-1

Product features

- The SU+PO/SU-PO taps are designed for stainless steel that causes work harden easily. The cutting geometry is also suited for tapping through holes in chromium steel and molybdenum steel.
- To prevent chip welding, the tap's surface is oxidized.

Comparison chart

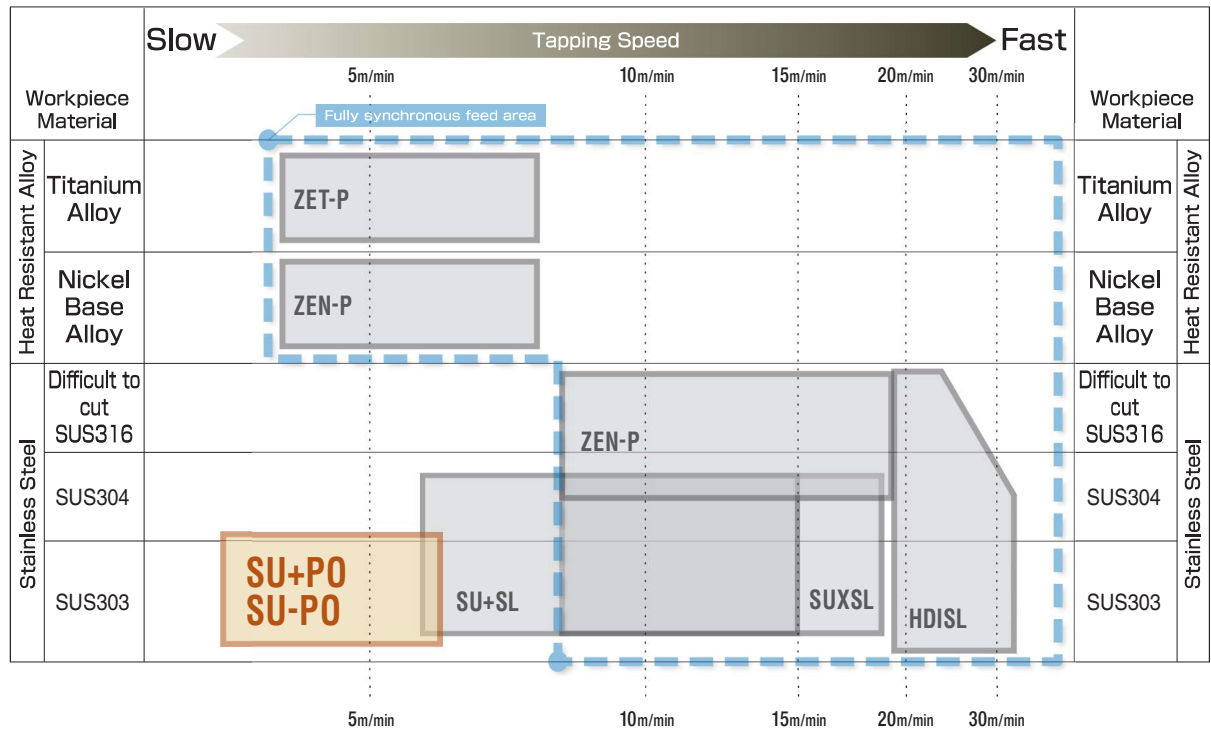

Speed range for the SU+PO/SU-PO taps.

JIS

③-55

Think threads with
YAMAWA

For improvement, spec may change without advance notice.

| Overall length | Thread length | Thread + Neck length | Shank length | Shank dia. | Size of square | Length of square |
|----------------|---------------|----------------------|--------------|------------|----------------|------------------|
| L | l | ln | ls | Ds | K | lk |

3

JIS

Spiral Fluted Taps
(for blind hole) ①

Spiral Fluted Taps
(for through hole) ②

Spiral Pointed Taps
(for through hole) ③

Hand Taps ④

Cemented Carbide Taps ⑤

Roll Taps ⑥

Special Thread Taps
Simple Inspection Tools ⑦

Pipe Taps ⑧

Thread Mills ⑨

Dies ⑩

Center Drills
Centering Tools ⑪

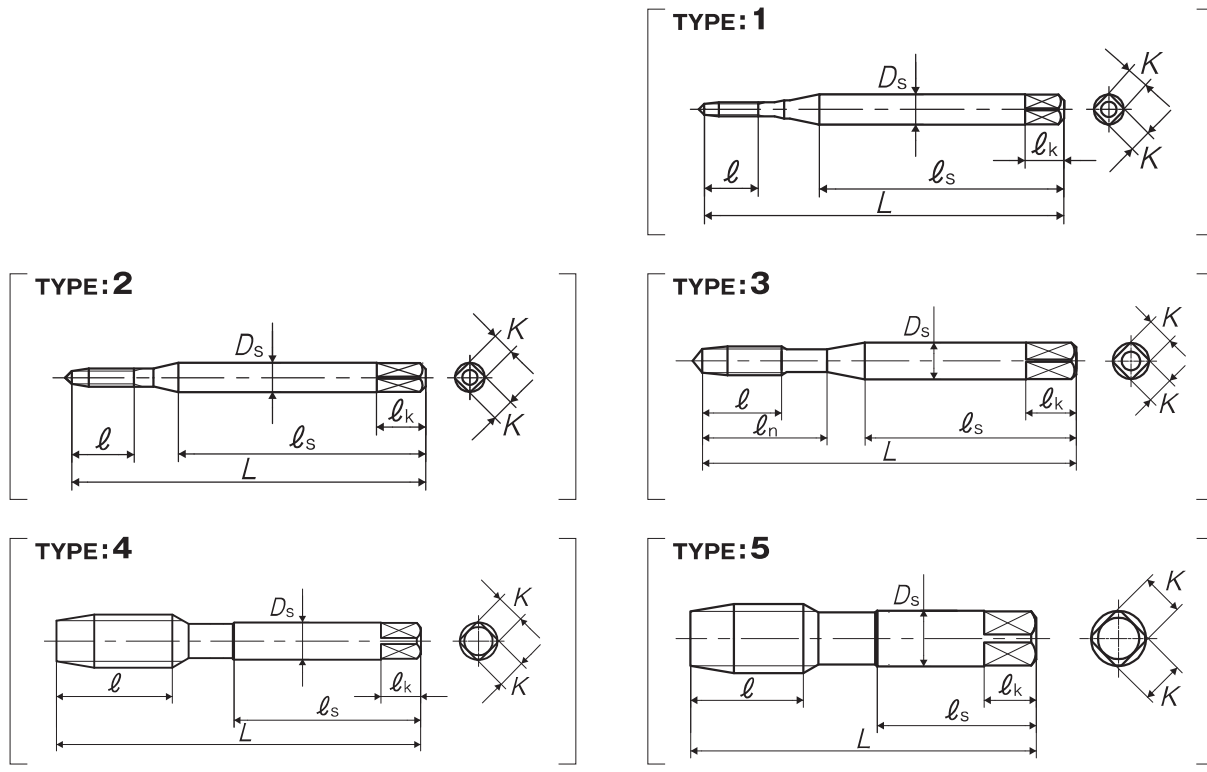

Oversize
Segment : 1E

| Size | Class | Code | Chamfer | L (mm) | l (mm) | ln (mm) | ls (mm) | Ds (mm) | K (mm) | lk (mm) | No. of flutes | TYPE | MSRP |
|--------------------|-------|----------|---------|--------|--------|---------|---------|---------|--------|---------|---------------|------|----------|
| For Metric Threads | | | | | | | | | | | | | |
| M1.4 × 0.3 | P1 | PUPP1.4C | 5P | 36 | 5.4 | - | 24 | 3 | 2.5 | 5 | 2 | 1 | ¥ 3,250* |
| M1.6 × 0.35 | P2 | PUPQ1.6D | 5P | 36 | 6.3 | - | 24 | 3 | 2.5 | 5 | 2 | 2 | ¥ 3,100* |
| M1.7 × 0.35 | P2 | PUPQ1.7D | 5P | 36 | 6.3 | - | 24 | 3 | 2.5 | 5 | 2 | 2 | ¥ 3,100* |
| M2 × 0.4 | P2 | PUPQ2.0E | 5P | 42 | 7.2 | 12 | 27 | 3 | 2.5 | 5 | 2 | 3 | ¥ 2,480 |
| M2 × 0.4 | P3 | PUPR2.0E | 5P | 42 | 7.2 | 12 | 27 | 3 | 2.5 | 5 | 2 | 3 | ¥ 2,480* |
| M2.3 × 0.4 | P2 | PUPQ2.3E | 5P | 42 | 7.2 | 12 | 27 | 3 | 2.5 | 5 | 2 | 3 | ¥ 2,260 |
| M2.3 × 0.4 | P3 | PUPR2.3E | 5P | 42 | 7.2 | 12 | 27 | 3 | 2.5 | 5 | 2 | 3 | ¥ 2,260* |
| M2.5 × 0.45 | P2 | PUPQ2.5F | 5P | 46 | 8.1 | 14 | 29 | 3 | 2.5 | 5 | 2 | 3 | ¥ 1,900 |
| M2.5 × 0.45 | P3 | PUPR2.5F | 5P | 46 | 8.1 | 14 | 29 | 3 | 2.5 | 5 | 2 | 3 | ¥ 1,900* |
| M2.6 × 0.45 | P2 | PUPQ2.6F | 5P | 46 | 8.1 | 14 | 29 | 3 | 2.5 | 5 | 2 | 3 | ¥ 1,900 |
| M2.6 × 0.45 | P3 | PUPR2.6F | 5P | 46 | 8.1 | 14 | 29 | 3 | 2.5 | 5 | 2 | 3 | ¥ 1,900* |
| M3 × 0.5 | P2 | PUMQ3.0G | 5P | 46 | 9 | 14 | 26 | 4 | 3.2 | 6 | 3 | 3 | ¥ 1,330 |
| M3 × 0.5 | P3 | PUMR3.0G | 5P | 46 | 9 | 14 | 26 | 4 | 3.2 | 6 | 3 | 3 | ¥ 1,330* |
| M3 × 0.5 | P4 | PUMS3.0G | 5P | 46 | 9 | 14 | 26 | 4 | 3.2 | 6 | 3 | 3 | ¥ 1,330* |
| 3M0.6 | P2 | PUMQ3.0H | 5P | 46 | 9 | 14 | 26 | 4 | 3.2 | 6 | 3 | 3 | ¥ 1,330* |
| M3.5 × 0.6 | P2 | PUMQ3.5H | 5P | 52 | 11 | 16 | 29 | 5 | 4 | 7 | 3 | 3 | ¥ 1,330 |
| M4 × 0.7 | P2 | PUMQ4.0I | 5P | 52 | 11 | 17 | 29 | 5 | 4 | 7 | 3 | 3 | ¥ 1,330 |
| M4 × 0.7 | P3 | PUMR4.0I | 5P | 52 | 11 | 17 | 29 | 5 | 4 | 7 | 3 | 3 | ¥ 1,330* |
| M4 × 0.7 | P4 | PUMS4.0I | 5P | 52 | 11 | 17 | 29 | 5 | 4 | 7 | 3 | 3 | ¥ 1,330* |
| 4M0.75 | P2 | PUMQ4.0J | 5P | 52 | 11 | 17 | 29 | 5 | 4 | 7 | 3 | 3 | ¥ 1,330* |
| M5 × 0.8 | P2 | PUMQ5.0K | 5P | 60 | 13 | 22 | 33 | 5.5 | 4.5 | 7 | 3 | 3 | ¥ 1,340 |
| M5 × 0.8 | P3 | PUMR5.0K | 5P | 60 | 13 | 22 | 33 | 5.5 | 4.5 | 7 | 3 | 3 | ¥ 1,340* |
| M5 × 0.8 | P4 | PUMS5.0K | 5P | 60 | 13 | 22 | 33 | 5.5 | 4.5 | 7 | 3 | 3 | ¥ 1,340* |
| 5M0.9 | P2 | PUMQ5.0L | 5P | 60 | 13 | 22 | 33 | 5.5 | 4.5 | 7 | 3 | 3 | ¥ 1,340* |

JIS

③-56

3 Spiral Pointed Tap Series for through hole

| Overall length | Thread length | Thread + Neck length | Shank length | Shank dia. | Size of square | Length of square |
|----------------|---------------|----------------------|--------------|------------|----------------|------------------|
| L | ℓ | ℓn | ℓs | Ds | K | ℓk |

JIS

SU+PO/SU-PO Spiral Pointed Taps for Stainless Steels

① Spiral Fluted Taps (for blind hole)

② Spiral Fluted Taps (for through hole)

③ Spiral Pointed Taps (for through hole)

④ Hand Taps

⑤ Cemented Carbide Taps

⑥ Roll Taps

⑦ Special Thread Taps Simple inspection tools

⑧ Pipe Taps

⑨ Thread Mills

⑩ Dies

⑪ Center Drills Centering Tools

| Size | Class | Code | Chamfer | L (mm) | ℓ (mm) | ℓn (mm) | ℓs (mm) | Ds (mm) | K (mm) | ℓk (mm) | No. of flutes | TYPE | MSRP |
|------------|-------|----------|---------|--------|--------|---------|---------|---------|--------|---------|---------------|------|------------|
| M6 × 1 | P2 | PUMQ6.0M | 5P | 62 | 15 | 26 | 33 | 6 | 4.5 | 7 | 3 | 3 | ¥ 1,480 |
| M6 × 1 | P3 | PUMR6.0M | 5P | 62 | 15 | 26 | 33 | 6 | 4.5 | 7 | 3 | 3 | ¥ 1,480** |
| M6 × 1 | P4 | PUMS6.0M | 5P | 62 | 15 | 26 | 33 | 6 | 4.5 | 7 | 3 | 3 | ¥ 1,480** |
| M6 × 0.75 | P2 | PUMQ6.0J | 5P | 62 | 15 | 26 | 33 | 6 | 4.5 | 7 | 3 | 3 | ¥ 2,070** |
| M7 × 1 | P2 | PUMQ7.0M | 5P | 70 | 19 | - | 36 | 6.2 | 5 | 8 | 3 | 4 | ¥ 1,800** |
| M8 × 1.25 | P3 | PUMR8.0N | 5P | 70 | 19 | - | 36 | 6.2 | 5 | 8 | 3 | 4 | ¥ 2,060** |
| M8 × 1.25 | P4 | PUMS8.0N | 5P | 70 | 19 | - | 36 | 6.2 | 5 | 8 | 3 | 4 | ¥ 2,060** |
| M8 × 1.25 | P5 | PUMT8.0N | 5P | 70 | 19 | - | 36 | 6.2 | 5 | 8 | 3 | 4 | ¥ 2,060** |
| M8 × 1 | P3 | PUMR8.0M | 5P | 70 | 19 | - | 36 | 6.2 | 5 | 8 | 3 | 4 | ¥ 2,340 |
| M10 × 1.5 | P3 | PUMR0100 | 5P | 75 | 23 | - | 38 | 7 | 5.5 | 8 | 3 | 4 | ¥ 2,630** |
| M10 × 1.5 | P4 | PUMS0100 | 5P | 75 | 23 | - | 38 | 7 | 5.5 | 8 | 3 | 4 | ¥ 2,630** |
| M10 × 1.5 | P5 | PUMT0100 | 5P | 75 | 23 | - | 38 | 7 | 5.5 | 8 | 3 | 4 | ¥ 2,630** |
| M10 × 1.25 | P3 | PUMR010N | 5P | 75 | 23 | - | 38 | 7 | 5.5 | 8 | 3 | 4 | ¥ 2,630** |
| M10 × 1.25 | P4 | PUMS010N | 5P | 75 | 23 | - | 38 | 7 | 5.5 | 8 | 3 | 4 | ¥ 2,630** |
| M10 × 1 | P3 | PUMR010M | 5P | 75 | 23 | - | 38 | 7 | 5.5 | 8 | 3 | 4 | ¥ 3,120** |
| M12 × 1.75 | P4 | PUMS012P | 5P | 82 | 26 | - | 42 | 8.5 | 6.5 | 9 | 3 | 4 | ¥ 3,720** |
| M12 × 1.75 | P5 | PUMT012P | 5P | 82 | 26 | - | 42 | 8.5 | 6.5 | 9 | 3 | 4 | ¥ 3,720** |
| M12 × 1.5 | P3 | PUMR0120 | 5P | 82 | 26 | - | 42 | 8.5 | 6.5 | 9 | 3 | 4 | ¥ 3,720** |
| M12 × 1.5 | P5 | PUMT0120 | 5P | 82 | 26 | - | 42 | 8.5 | 6.5 | 9 | 3 | 4 | ¥ 3,720** |
| M12 × 1.25 | P4 | PUMS012N | 5P | 82 | 26 | - | 42 | 8.5 | 6.5 | 9 | 3 | 4 | ¥ 3,720** |
| M12 × 1.25 | P5 | PUMT012N | 5P | 82 | 26 | - | 42 | 8.5 | 6.5 | 9 | 3 | 4 | ¥ 3,720** |
| M12 × 1 | P3 | PUMR012M | 5P | 82 | 26 | - | 42 | 8.5 | 6.5 | 9 | 3 | 4 | ¥ 4,370** |
| M14 × 2 | P4 | PUMS014Q | 5P | 88 | 26 | - | 45 | 10.5 | 8 | 11 | 3 | 4 | ¥ 5,080** |
| M14 × 2 | P5 | PUMT014Q | 5P | 88 | 26 | - | 45 | 10.5 | 8 | 11 | 3 | 4 | ¥ 5,080** |
| M14 × 1.5 | P3 | PUMR0140 | 5P | 88 | 26 | - | 45 | 10.5 | 8 | 11 | 3 | 4 | ¥ 5,080** |
| M14 × 1.5 | P5 | PUMT0140 | 5P | 88 | 26 | - | 45 | 10.5 | 8 | 11 | 3 | 4 | ¥ 5,080** |
| M14 × 1 | P3 | PUMR014M | 5P | 88 | 26 | - | 45 | 10.5 | 8 | 11 | 3 | 4 | ¥ 5,890** |
| M15 × 1.5 | P3 | PUMR0150 | 5P | 95 | 26 | - | 48 | 12.5 | 10 | 13 | 3 | 4 | ¥ 6,780** |
| M15 × 1 | P3 | PUMR015M | 5P | 95 | 26 | - | 48 | 12.5 | 10 | 13 | 3 | 4 | ¥ 8,080** |
| M16 × 2 | P4 | PUMS016Q | 5P | 95 | 26 | - | 48 | 12.5 | 10 | 13 | 3 | 4 | ¥ 6,780** |
| M16 × 2 | P5 | PUMT016Q | 5P | 95 | 26 | - | 48 | 12.5 | 10 | 13 | 3 | 4 | ¥ 6,780** |
| M16 × 2 | P6 | PUMU016Q | 5P | 95 | 26 | - | 48 | 12.5 | 10 | 13 | 3 | 4 | ¥ 6,780** |
| M16 × 1.5 | P3 | PUMR0160 | 5P | 95 | 26 | - | 48 | 12.5 | 10 | 13 | 3 | 4 | ¥ 6,780** |
| M16 × 1.5 | P5 | PUMT0160 | 5P | 95 | 26 | - | 48 | 12.5 | 10 | 13 | 3 | 4 | ¥ 6,780** |
| M16 × 1 | P3 | PUMR016M | 5P | 95 | 26 | - | 48 | 12.5 | 10 | 13 | 3 | 4 | ¥ 8,080** |
| M18 × 2.5 | P4 | PUMS018R | 5P | 100 | 33 | - | 51 | 14 | 11 | 14 | 3 | 4 | ¥ 9,060** |
| M18 × 2.5 | P5 | PUMT018R | 5P | 100 | 33 | - | 51 | 14 | 11 | 14 | 3 | 4 | ¥ 9,060** |
| M18 × 2.5 | P6 | PUMU018R | 5P | 100 | 33 | - | 51 | 14 | 11 | 14 | 3 | 4 | ¥ 9,060** |
| M18 × 1.5 | P4 | PUMS0180 | 5P | 100 | 33 | - | 51 | 14 | 11 | 14 | 3 | 4 | ¥ 9,060** |
| M18 × 1.5 | P5 | PUMT0180 | 5P | 100 | 33 | - | 51 | 14 | 11 | 14 | 3 | 4 | ¥ 9,060** |
| M20 × 2.5 | P4 | PUMS020R | 5P | 105 | 33 | - | 50 | 15 | 12 | 15 | 3 | 5 | ¥ 12,400 |
| M20 × 2.5 | P5 | PUMT020R | 5P | 105 | 33 | - | 50 | 15 | 12 | 15 | 3 | 5 | ¥ 12,400** |
| M20 × 2.5 | P6 | PUMU020R | 5P | 105 | 33 | - | 50 | 15 | 12 | 15 | 3 | 5 | ¥ 12,400** |
| M20 × 1.5 | P4 | PUMS0200 | 5P | 105 | 33 | - | 50 | 15 | 12 | 15 | 3 | 5 | ¥ 12,400** |
| M20 × 1.5 | P5 | PUMT0200 | 5P | 105 | 33 | - | 50 | 15 | 12 | 15 | 3 | 5 | ¥ 12,400** |
| M22 × 2.5 | P4 | PUMS022R | 5P | 115 | 33 | - | 55 | 17 | 13 | 16 | 3 | 5 | ¥ 15,800** |
| M22 × 2.5 | P5 | PUMT022R | 5P | 115 | 33 | - | 55 | 17 | 13 | 16 | 3 | 5 | ¥ 15,800** |
| M22 × 2.5 | P6 | PUMU022R | 5P | 115 | 33 | - | 55 | 17 | 13 | 16 | 3 | 5 | ¥ 15,800** |
| M22 × 1.5 | P4 | PUMS0220 | 5P | 115 | 33 | - | 55 | 17 | 13 | 16 | 3 | 5 | ¥ 15,800** |
| M22 × 1.5 | P5 | PUMT0220 | 5P | 115 | 33 | - | 55 | 17 | 13 | 16 | 3 | 5 | ¥ 15,800** |

JIS



** = Specified Distribution Items. Made to order products.
For improvement, spec may change without advance notice.

| | | | | | | |
|----------------|---------------|----------------------|--------------|------------|----------------|------------------|
| Overall length | Thread length | Thread + Neck length | Shank length | Shank dia. | Size of square | Length of square |
| L | ℓ | ℓn | ℓs | Ds | K | ℓk |

3

JIS

SU+PO/SU-PO Spiral Pointed Taps for Stainless Steels

| Size | Class | Code | Chamfer | L (mm) | ℓ (mm) | ℓn (mm) | ℓs (mm) | Ds (mm) | K (mm) | ℓk (mm) | No. of flutes | TYPE | MSRP |
|-----------------------|-------|----------|---------|--------|--------|---------|---------|---------|--------|---------|---------------|------|-----------|
| M24 × 3 | P4 | PUMS024S | 5P | 120 | 39 | - | 55 | 19 | 15 | 18 | 3 | 5 | ¥ 19,700 |
| M24 × 3 | P5 | PUMT024S | 5P | 120 | 39 | - | 55 | 19 | 15 | 18 | 3 | 5 | ¥ 19,700* |
| M24 × 3 | P6 | PUMU024S | 5P | 120 | 39 | - | 55 | 19 | 15 | 18 | 3 | 5 | ¥ 19,700* |
| M24 × 1.5 | P4 | PUMS0240 | 5P | 120 | 39 | - | 55 | 19 | 15 | 18 | 3 | 5 | ¥ 19,700* |
| M27 × 3 | P4 | PUMS027S | 5P | 130 | 39 | - | 60 | 20 | 15 | 18 | 4 | 5 | ¥ 27,900* |
| M27 × 1.5 | P4 | PUMS0270 | 5P | 130 | 39 | - | 60 | 20 | 15 | 18 | 4 | 5 | ¥ 27,900* |
| M30 × 3.5 | P5 | PUMT030T | 5P | 135 | 46 | - | 62 | 23 | 17 | 20 | 4 | 5 | ¥ 35,600* |
| M30 × 1.5 | P4 | PUMS0300 | 5P | 135 | 46 | - | 62 | 23 | 17 | 20 | 4 | 5 | ¥ 35,600* |
| M33 × 3.5 | P5 | PUMT033T | 5P | 145 | 46 | - | 67 | 25 | 19 | 22 | 4 | 5 | ¥ 41,400* |
| M36 × 4 | P5 | PUMT036U | 5P | 155 | 52 | - | 71 | 28 | 21 | 24 | 4 | 5 | ¥ 48,000* |
| M39 × 4 | P5 | PUMT039U | 5P | 165 | 52 | - | 76 | 30 | 23 | 26 | 4 | 5 | ¥ 55,000* |
| M42 × 4.5 | P5 | PUMT042V | 5P | 175 | 59 | - | 81 | 32 | 26 | 30 | 4 | 5 | ¥ 66,900* |
| For Unified Threads | | | | | | | | | | | | | |
| No.2-56UNC | P1 | PUMPUN2E | 5P | 42 | 8.1 | 12 | 27 | 3 | 2.5 | 5 | 2 | 3 | ¥ 2,590* |
| No.4-40UNC | P2 | PUMQUN4H | 5P | 46 | 9 | 14 | 25 | 4 | 3.2 | 6 | 2 | 3 | ¥ 1,670* |
| No.4-48UNF | P1 | PUMPUN4F | 5P | 46 | 9 | 14 | 25 | 4 | 3.2 | 6 | 2 | 3 | ¥ 1,670* |
| No.5-40UNC | P2 | PUMQUN5H | 5P | 52 | 11 | 16 | 28 | 5 | 4 | 7 | 3 | 3 | ¥ 1,560* |
| No.5-44UNF | P1 | PUMPUN5G | 5P | 52 | 11 | 16 | 28 | 5 | 4 | 7 | 3 | 3 | ¥ 1,560* |
| No.6-32UNC | P2 | PUMQUN6J | 5P | 52 | 11 | 17 | 27 | 5 | 4 | 7 | 3 | 3 | ¥ 1,560* |
| No.6-40UNF | P2 | PUMQUN6H | 5P | 52 | 11 | 17 | 27 | 5 | 4 | 7 | 3 | 3 | ¥ 1,560* |
| No.8-32UNC | P2 | PUMQUN8J | 5P | 60 | 13 | 22 | 31 | 5.5 | 4.5 | 7 | 3 | 3 | ¥ 1,570* |
| No.8-36UNF | P2 | PUMQUN8I | 5P | 60 | 13 | 22 | 31 | 5.5 | 4.5 | 7 | 3 | 3 | ¥ 1,600* |
| No.10-24UNC | P2 | PUMQUNAM | 5P | 60 | 13 | 22 | 32 | 5.5 | 4.5 | 7 | 3 | 3 | ¥ 1,600* |
| No.10-32UNF | P2 | PUMQUAJ | 5P | 60 | 13 | 22 | 32 | 5.5 | 4.5 | 7 | 3 | 3 | ¥ 1,600* |
| 1/4-20UNC | P2 | PUMQU04N | 5P | 62 | 15 | 26 | 33 | 6 | 4.5 | 7 | 3 | 3 | ¥ 1,700* |
| 1/4-28UNF | P2 | PUMQU04K | 5P | 62 | 15 | 26 | 33 | 6 | 4.5 | 7 | 3 | 3 | ¥ 1,700* |
| 5/16-18UNC | P3 | PUMRU050 | 5P | 70 | 19 | - | 36 | 6.2 | 5 | 8 | 3 | 4 | ¥ 2,370* |
| 5/16-24UNF | P2 | PUMQU05M | 5P | 70 | 19 | - | 36 | 6.2 | 5 | 8 | 3 | 4 | ¥ 2,370* |
| 3/8-16UNC | P3 | PUMRU06P | 5P | 75 | 23 | - | 38 | 7 | 5.5 | 8 | 3 | 4 | ¥ 3,040* |
| 3/8-24UNF | P2 | PUMQU06M | 5P | 75 | 23 | - | 38 | 7 | 5.5 | 8 | 3 | 4 | ¥ 3,040* |
| 7/16-14UNC | P3 | PUMRU07Q | 5P | 82 | 26 | - | 42 | 8.5 | 6.5 | 9 | 3 | 4 | ¥ 4,280* |
| 7/16-20UNF | P3 | PUMRU07N | 5P | 82 | 26 | - | 42 | 8.5 | 6.5 | 9 | 3 | 4 | ¥ 4,280* |
| 1/2-13UNC | P3 | PUMRU08R | 5P | 88 | 26 | - | 45 | 10.5 | 8 | 11 | 3 | 4 | ¥ 4,550* |
| 1/2-20UNF | P3 | PUMRU08N | 5P | 88 | 26 | - | 45 | 10.5 | 8 | 11 | 3 | 4 | ¥ 4,550* |
| 9/16-18UNF | P3 | PUMRU090 | 5P | 95 | 26 | - | 48 | 12.5 | 10 | 13 | 3 | 4 | ¥ 6,780* |
| 5/8-11UNC | P3 | PUMRU10U | 5P | 95 | 26 | - | 48 | 12.5 | 10 | 13 | 3 | 4 | ¥ 6,780* |
| For Whitworth Threads | | | | | | | | | | | | | |
| 3/16W24 | P2 | PUMQW03M | 5P | 60 | 13 | 21 | 33 | 5.5 | 4.5 | 7 | 3 | 3 | ¥ 1,570* |
| 1/4W20 | P3 | PUMRW04N | 5P | 62 | 15 | 26 | 33 | 6 | 4.5 | 7 | 3 | 3 | ¥ 1,680* |
| 5/16W18 | P3 | PUMRW050 | 5P | 70 | 19 | - | 36 | 6.2 | 5 | 8 | 3 | 4 | ¥ 2,370* |
| 3/8W16 | P3 | PUMRW06P | 5P | 75 | 23 | - | 38 | 7 | 5.5 | 8 | 3 | 4 | ¥ 3,040* |
| 7/16W14 | P3 | PUMRW07Q | 5P | 82 | 26 | - | 42 | 8.5 | 6.5 | 9 | 3 | 4 | ¥ 4,280* |
| 1/2W12 | P3 | PUMRW08S | 5P | 88 | 26 | - | 45 | 10.5 | 8 | 11 | 3 | 4 | ¥ 4,550* |
| 5/8W11 | P3 | PUMRW10U | 5P | 95 | 26 | - | 48 | 12.5 | 10 | 13 | 3 | 4 | ¥ 6,780* |
| 3/4W10 | P4 | PUMSW12V | 5P | 105 | 33 | - | 50 | 15 | 12 | 15 | 3 | 5 | ¥ 12,400* |
| 1 W8 | P4 | PUMSW16X | 5P | 125 | 39 | - | 58 | 19 | 15 | 18 | 3 | 5 | ¥ 25,900* |

Spiral Fluted Taps
(for blind hole) ①Spiral Fluted Taps
(for through hole) ②Spiral Pointed Taps
(for through hole) ③

Hand Taps ④

Cemented Carbide Taps ⑤

Roll Taps ⑥

Special Thread Taps
Simple Inspection Tools ⑦

Pipe Taps ⑧

Thread Mills ⑨

Dies ⑩

Center Drills
Centering Tools ⑪

* = Specified Distribution Items. Made to order products.
For improvement, spec may change without advance notice.

Think threads with
YAMAWA

JIS

③-58