

OPERATION AND MAINTENANCE MANUAL

SKD-BE830L

SKD-BE850L

SKD-BE830LF

SKD-BE830P

SKD-BE850P

SKD-BE830PF

Ver. 4.0

Please scan the following QR code or download
the operation manual from KILEWS website

<https://www.kilews.com.tw/tc/download-list.php>

DC-TYPE Automatic Non-Carbon-Brush with Counter Series

KILEWS INDUSTRIAL CO., LTD.

<http://www.kilews.com>



Y2F055Q-9E-001

NOTICE

Metal Assembly Screwdrivers are designed for installing threaded fasteners in light industrial and appliance manufacturing applications.

KILEWS is not responsible for customer modification of tools for applications on which KILEWS was not consulted.

WARNING

Important safety information enclosed.

Read all these instructions before placing tool in service or operation this tool and save these instructions. It is the responsibility of the employer to place the information in this manual into the hands of the operator. Failure to observe the following warnings could result in injury. When using electric tools, Basic safety precautions should always be followed to reduce the risk of fire, electric shock and personal injury, including the following:

Important Safety Rules

WARNING! Read all instructions Failure to follow all instructions listed below may result in electric shock fire and/or serious injury. The term “power tool” in all of the warning listed below refers to your mains operated (corded) power tool or battery operated (cordless) power tool.

SAVE THESE INSTRUCTIONS

1) Electrical Safety

- a) **Keep work area clean and well lit.** Cluttered and dark areas invite accidents.
- b) **Do not operate power tools in explosive atmosphere, such as in the presence of flammable liquids, gases or dust.** Power tools create sparks which may ignite the dust of fumes.
- c) **Keep children and bystanders away while operating a power tool.** Distractions can cause you to lose control.

2) Electrical Safety

- a) **Power tool plugs must match the outlet. Never modify the plug in any way. Do not use any adapter plugs with earthed (grounded) power tools.** Unmodified plugs and matching outlets will reduce risk of electric shock.
- b) **Avoid body contact with earthed or grounded surfaces such as pipes, radiators, ranges and refrigerators.** There is an increased risk of electric shock if your body is earthed or grounded.
- c) **Don't expose power tools to rain or wet conditions.** Water entering a power tool will increase the risk of electric shock.
- d) **Do not abuse the cord. Never use the cord to carry, pulling or unplugging the power tool. Keep cord away from heat, oil, sharp edges or moving parts.** Damaged or entangled cords increase the risk of electric shock.
- e) **When operating a power tool outdoors, use an extension cord suitable for outdoor use.** Use of cord suitable for outdoor use reduces the risk of electric shock.

3) Personal Safety

- a) **Stay alert, watch what you are doing and use common sense when operating a power tool. Do not use power tool while you are tired or under the influence of drugs, alcohol, or medication.** A moment of inattention while operating power tools may result in serious personal injury.
- b) **Use safety equipment. Always wear eye protection.** Safety equipment such as dust mask, non-skid safety shoes, hard hat, or hearing protection used for appropriate conditions will reduce personal injuries.
Rubber gloves and non-skid footwear are recommended when working outdoors.
- c) **Avoid accidental starting. Ensure the switch is in the off position before plugging in.** Carrying power tools with your finger on the switch or plugging in power tools that have the switch on invites accidents.
- d) **Remove any adjusting keys or wrench before turning the power tool on.** A wrench or a key that is left attached to a rotating part of the power tool may result in personal injury.
- e) **Do not overreach. Keep proper footing and balance at all times.** This enables better control of the power tool in unexpected situations.
- f) **Dress properly. Do not wear loose clothing or jewelry. Keep your hair, clothing, and gloves away from moving parts.** Loose clothes, jewelry, or long hair can be caught in moving parts
- g) **Secure work.** Use clamps or a vice to hold the work. It is safer than using your hand and frees both hands to operate the tool.
- h) **If devices are provided for the connection of dust extraction and collection facilities, ensure these are connected and properly used.** Use of these devices can reduce dust related hazards.
- i) **Use a safety device.** Wear protective earmuffs to reduce personal injury.

Noise:

The typical A-weighted noise level acc. To EN62841-2-2

.Sound pressure level(LpA): 53.6 dB(A)

.Sound power level(LwA): 64.6 dB(A)

Vibration:

The vibration total value acc. EN62841-2-2

.Vibration emission value ah (m/s²): 0.17 m/s²

.Uncertainty K (m/s²): 0.02 m/s²

4) Power tool Use and Care

- a) **Do not force the power tool. Use the correct power tool for your application.** The correct power tool will do the job better and safer at the rate for which it was designed.
- b) **Do not use power tool if switch does not turn it on or off.** Any power tool that cannot be controlled with the switch is dangerous and must be repaired.
- c) **Disconnect the plug from the power source before making any adjustments, changing accessories, or storing the power tools.** Such preventive safety measures reduce the risk of starting the power tool accidentally.

d) **Store idle power tools out of reach of children and do not allow persons unfamiliar with the power tool or these instructions to operate the power tool.** Power tools are dangerous in the hands of untrained users.

Do not let visitors touch the tool or extension cord. All visitors should be kept away from work area.

e) **Maintain power tools. Check for misalignment or binding of moving parts, breakage of parts and any other condition that may affect the power tools operation. If damaged, have the power tool repaired before use.** Many accidents are caused by poorly maintained power tools.

Inspect extension cords periodically and replace, if damaged.

f) **Keep cutting tools sharp and clean,** properly maintained cutting tools with sharp cutting edges are less likely to bind and are easier to control.

g) **Use the power tools, accessories and tool bits etc., in accordance with these instructions and in the manner intended for the particular type of power tool, taking into account the working conditions and the work to be performed.** Use of the power tool for operations different from intended could result in a hazardous situation.

5) SERVICE

a) Have your power tool serviced by qualified repair person using only identical replacement parts, this will ensure that the safety of the power tool is maintained.

Additional information shall be provided

a) Instruction for putting into use

1. Setting-up or fixing power tool in a stable position as appropriate for power tools which can be mounted on a support.
2. Assembly
3. Connection to power supply, cabling, fusing, socket type and earthing requirements.
4. Illustrated description of functions.
5. Limitations on ambient conditions.
6. List of contents.

b) Operating Instructions.

- | | |
|----------------------------------|----------------------------------|
| 1. Setting and testing. | 2. Tool changing. |
| 3. Clamping of work. | 4. Limits on size of work piece. |
| 5. General instructions for use. | |

c) Maintenance and servicing.

1. Regular cleaning, maintenance, and lubrication.
2. Servicing by manufacture or agent, list of addresses.
3. List of user-replaceable parts.
4. Special tools which may be required.

6) Clamp fixed position for 3cm Nylon Fixed-Wire

The clamp fixed position for 3cm Nylon Fixed-Wire is at 235mm start count from the top of the screwdriver flat surface (for direct cable), as shown in Figure 1.

The clamp fixed position for 3cm Nylon Fixed-Wire is at 285mm start count from the top of the screwdriver flat surface (for 15 cm tail cable), as shown in Figure 2.

The clamp fixed position for 3cm Nylon Fixed-Wire is at 390mm start count from the top of the screwdriver flat surface (for Iron ring socket type), as shown in Figure 3.

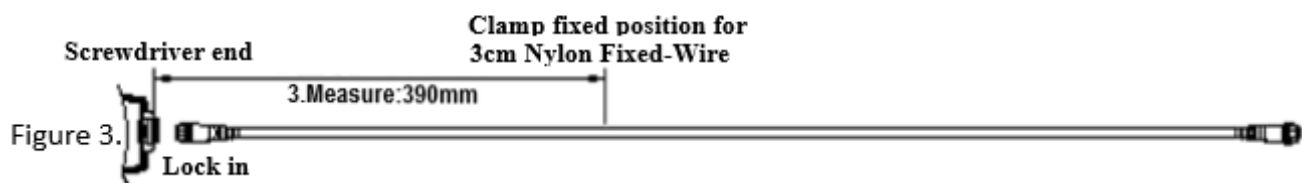
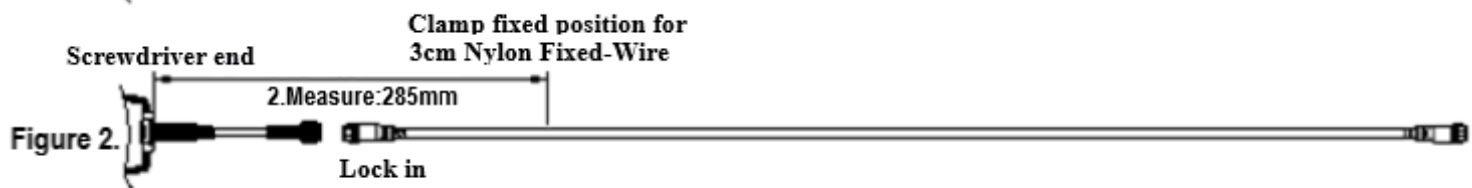
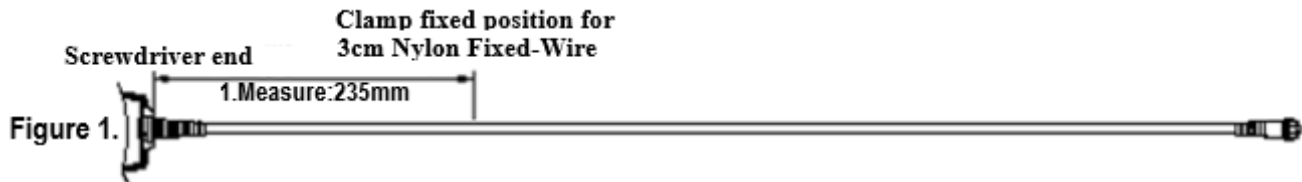

WARNING !

DO NOT OPERATE THIS TOOL WITHOUT PROTECTIVE EARTH CONNECTED

Grounding Instructions

1. This tool should be grounded while in use to protect the operator from electric shock. NOTICE! To ensure the grounding result, the grounding conductor of the power cord must be well connected with the grounding terminal of power facility. This tool is equipped with grounding conductors. The Green (or Green and Yellow) conductor in the Power Cord is the grounding wire. Never connect Green (or Green and Yellow) to a live terminal. The grounding wires in this tool can not only earth the electric leakage safely, but also can eliminate ESD-the electrostatic that tool occurred while in use.
2. The grounding is the most important task a user. Periodically, depends on the working condition and circumstance, for maintaining a good function the user has to check the grounding condition every 3~6 months by an electric meter and following simple steps; Set the Ohm meter to level R*100(Ohm). Touching 2 test rods (“+” & “-”) together and reset the meter to “0”. Using the Red(“+”) rod to touch the Grounding wire on the Plug of controller’s cord, and the Black(“-”) rod to the end of Bit Head. It stands for the grounding is normal if the meter is read as close as to “0”. For getting a normal indication on the meter while in testing, need to press the test rods firmly to the testing objects.
3. The instrument QC of the tool is performed before the tool ex-factory. The grounding continuity test is conducted by input 26A voltage to the end of earth terminal, and subject to the resistance value lower than 0.3Ohm.

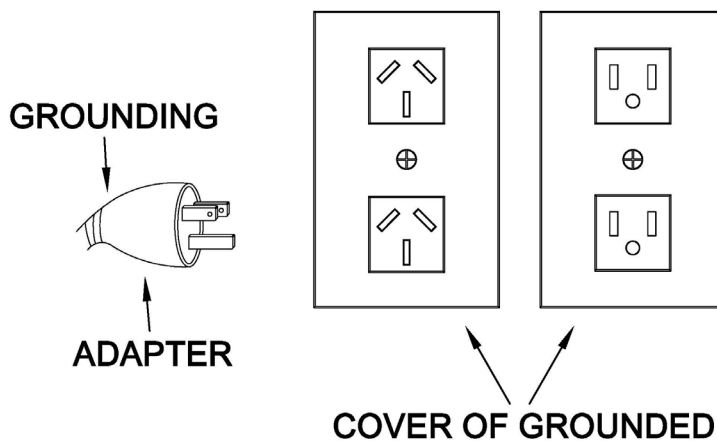

Operations Cautions

- 1) Before changing bits from BE Series screwdriver, make sure the Forward / Reverse switch stays at the “OFF” position
The screwdriver must be unplugged.
- 2) To avoid damaging the housing of screwdriver, do not allow chemicals get in touch with housing of screwdriver. Ex.: Acetone, benzene, thinner, trichloroethylene ketone, and other similar chemicals.
- 3) Use screwdriver carefully, do not drop or abuse. It would be better to use with the spring balancer. If without spring balancer, you can place the screwdriver in the suspension rack.
- 4) Do not adjust the torque setting higher than 8 on the torque scale.
- 4) Assemble / disassemble bits : Only use fingers pull up the bit sleeve to release bits. ; Place back the bit sleeve to lock the bit holder.
Attention : Make sure the power is off, or the Forward / Reverse switch stays at “OFF” position when assemble or disassemble bits.
- 5) Connect the plug to the socket. Attention : It will cause an electric shock if the plug or the hand is wet.
- 6) You can adjust the torque by the torque adjusting ring. The number on the scale is not equal to the real torque, please refer to our torque range chart or test the torque by our torque meter.
Attention : Do not adjust the torque setting higher than 8 on the torque scale.
- 7) BE Series screwdriver : When fasten a screw, please point the bit to left, move down the Forward / Reverse switch to the bottom. (If the screw is reversed-thread screw, move up the Forward / Reverse switch to the top.) Point at the place of the bit and the screw, press the trigger to start; When torque reaches user’s setting, the clutch will shut out automatically, the power will shut off and the motor breaks immediately, the screwdriver stop running.
- 8) Trigger Start Type screwdriver : When loosen a fastened screw, please set Forward / Reverse switch to “Reverse”.
(If the screw is reversed-thread screw, please set Forward / Reverse switch to “Forward”).
Follow the above operation, after loosening the screw, release the trigger to stop.
Push Start Type screwdriver : When loosen a fastened screw, please set Forward / Reverse switch to “Reverse”
(If the screw is reversed-thread screw, please set Forward / Reverse switch to “Forward”).
Follow the above operation, after loosening the screw, stop pushing the screwdriver to stop.
- 9) Operation frequency: The original setting of the frequency is 1 sec on / 3 sec off. The number of screws fastened is about 15 pcs.
Over frequently using makes the motor overheated and damage to screwdriver.
Enough heat-dissipation is good for screwdriver.
Slow speed Duty Cycle Conversion (for reference)
Based on 1000 rpm, 1 second ON/3 seconds OFF. For example, the duty cycle for 350rpm, $1000-350=650$,
 $650/1000\%=65\%$
 $ON= 1*1.65= 1.65$, $OFF =3*1.65 =4.95$ (rounded value) $=2$ seconds ON / 5 seconds OFF
This tool is intended for a duty cycle of 2.0 sec on, 5.0 sec off.

Slow speed (rpm)	operation frequency	Slow speed (rpm)	operation frequency	Slow speed (rpm)	operation frequency
900	1.0 ON 3.0 OFF	600	1.0 ON 3.0 OFF	300	2.0 ON 5.0 OFF
850	1.0 ON 3.0 OFF	550	2.0 ON 5.0 OFF	250	2.0 ON 5.0 OFF
800	1.0 ON 3.0 OFF	500	2.0 ON 5.0 OFF	200	2.0 ON 5.0 OFF
750	1.0 ON 3.0 OFF	450	2.0 ON 5.0 OFF	150	2.0 ON 5.0 OFF
700	1.0 ON 3.0 OFF	400	2.0 ON 5.0 OFF	100	2.0 ON 5.0 OFF
650	1.0 ON 3.0 OFF	350	2.0 ON 5.0 OFF		

- 10) Do not use this screwdriver for tightening wood screws. This is “Metal Assembly Screwdriver”
- 11) Do not operate the Forward / Reverse switch when the motor is running.
- 12) Whenever a screwdriver is not being used, move the Forward / Reverse switch to the “OFF” position and unplug the screwdriver.
- 13) Keep staying aware.
Pay attention on your work, check safety measures and every part is workable before using screwdrivers, to make sure screwdrivers can work under original design function.
- 14) Don't touch Forward & Reverse Switch during operating for keeping system from wrong judgment.

CAUTION

- Do not drop or abuse the tool.
- Whenever a tool is not being used, position the Power Switch to the “OFF” position and unplug the power cord.

Description of Operation

Attaching / detaching bit and bit type

Push up the holder clamp by fingertip, and it will be unlocked. Thus, the bit can be freely attached and detached (single finger notion type) select such a bit whose shank is equal to the size shown below.

- Insert the power plug into a receptacle and set the changeover switch to “F” position.
- Apply the bit to the screw head and press the lever or push main body to, then the switch will be turned ON to start the motor running.
- When the screw is tightened and reach the torque that you had set, the tool will be stopped automatically.
- To reset the tool by releasing the lever to the original position or releasing the bit from the screw head.
- To return the screw, set the changeover switch to “R” position.

Hi/Lo Switch

When the BE Series rotating speed needs to be changed, set up the switch to Hi for the fastest rotation, and set up the switch to Lo for slowest rotation. It's possible that the uncompleted shut-off occurs when the switch is setup to Lo and the presetting torque is more than 50% of torque range. Please refer to the following table.

Lo Switch	BE830L	BE830LF	BE850L	BE830P	BE830PF	BE850P
NG	15(Kgf)↓	15(Kgf)↓	25(Kgf)↓	15(Kgf)↓	15(Kgf)↓	25(Kgf)↓
OK	15(Kgf)↑	15(Kgf)↑	25(Kgf)↑	15(Kgf)↑	15(Kgf)↑	25(Kgf)↑

Servicing

Maintenance and Inspection:

1. The screwdriver must be operated in top condition, one day working hour must be not more than eight hours. according to operating frequency and torque loaded, we suggest adding lubricating oils in clutch per 3-6 months, and kindly contact with distributor when product's maintenance.
2. Please note don't let the motor get over heated, every minute use 10~15 screws to operate.
3. The frequency use of this electric screwdriver is over than eight hours a day, still it needs periodically testing and treatment. Every 5-6 months.
4. Inspect tool cords periodically and if damaged, have them repaired by an authorized service facility. Inspect extension cords periodically and replace if damaged.
5. Do not remove any labels. Replace any damaged label.

CAUTION

1. The use of other than genuine KILEWS replacement parts may Result in decreased tool performance and increased maintenance and may invalidate all warranties.
2. All repairs and maintenance of this tool and its word must be performed by an authorized service center.
3. KILEWS is not responsible for customer modification of tools for applications on which KILEWS was not consulted.
4. Repairs should be made only by authorized, trained personnel. Consult your nearest KILEWS authorized service center.
5. It is the responsibility of the employer to place the information in this manual into the hands of the operator.

**DO NOT ATTEMPT TO REPAIR THIS
ELECTRIC SCREWDRIVER**

CAUTION

**SAVE THESE INSTRUCTIONS
DO NOT DESTROY**

Specifications

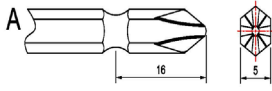
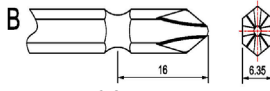
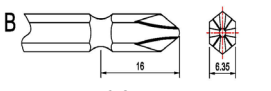
MODEL	SKD-BE830L	SKD-BE830P	SKD-BE830LF	SKD-BE830PF	SKD-BE850L	SKD-BE850P	
Input voltage(DC)	DC 40V						
Power Consumption	90W	90W	90W	90W	120W	120W	
Torque	(kgf.cm)	10-30	10-30	10-30	10-30	20-50	20-50
	(Lbf.in)	8.67-26.02	8.67-26.02	8.67-26.02	8.67-26.02	17.35-43.37	17.35-43.37
	(N.m)	0.98-2.94	0.98-2.94	0.98-2.94	0.98-2.94	1.96-4.90	1.96-4.90
Repeatable Torque Accuracy (%)	±3%						
Torque Adjustment	Stepless						
Unloaded Rotation Speed (r.p.m) ±10%	HI	1000	1000	2000	2000	1000	1000
Screw Size Dia (mm)	Machine screw	2.6~4.0	2.6~4.0	2.6~4.0	2.6~4.0	4.0~5.0	4.0~5.0
	Tapping screw	2.6~3.5	2.6~3.5	2.6~3.5	2.6~3.5	≤4	≤4
Weight (g)	820						
Length (mm)	294						
Model of Torque Fixing Ring	KC-7						
Power controller	SKP-40B						
Model of Suspension Rack	KH-2						
Bit Type							
	HEX 5mm				HEX 6.35mm		
							
	HEX 6.35mm						

* 1N.m=10.2Kgf.cm 1N.m=8.85Lbf.in

Accessories

1. Bit Type : No. 00 . . . Bit use in dia 1.3~1.8mm screw
 No. 0 Bit use in dia 1.8~2.0mm screw
 No. 1 Bit use in dia 2.0~2.6mm screw
 No. 2 Bit use in dia 3.0~4.0mm screw

SKD-BE830 series with BIT 2# 2 Pcs.

2. Suspension rack and Torque fixing ring acceptable for use with the tool are available from KILEWS catalogue.
3. Torque Fixing Ring (KC-6C) 1 Pcs.

Panel Specifications

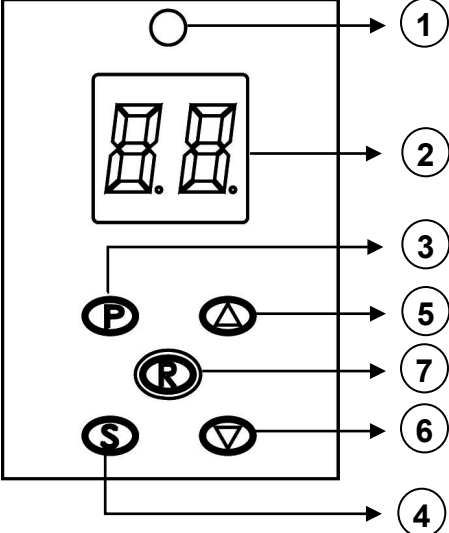
	No	Name	Function
	1	Three-Color Light	To Show operating is OK, N.G or in the mode condition.
	2	Panel	To show set value, set screws number and other value
	3	Power Switch	Push five seconds: to disable COUNTING FUNCTION CLEAR Push three seconds: CLEAR
	4	SELECT Key	Push three seconds: Enter the system
	5	Up Key	When entering the system , these key increases value
	6	Down Key	When entering the system , these key decreases value This key is symbolized to reduce numbers when press it on setting menu from system. This key also will become numbering of tasks if it works under working page.
	7	Reset	Restore to factory settings
	※	S+P	Automatic learning.
	※	UP+P	Set OKALL display mode.
	※	UP+DOWN	Buzzer mode
	※	S+UP	If press together to enable P/R/S button, and then press again to disable P/R/S button.

Counting Set-Up instruction

※ Push three seconds to enter the selection) SL==SC==At==RC==SP==Ht==Lt==LL==Ns==Rn==Rt <Confirm>

Function Name	Set up Time and Value	Description	Buzz Time/ Light	Factory default settings
SL	01-UU	Screw List : Screw List (The tightening process will not count if SC sets as 0 at U1 and screws displayed as 00)	An U1 is the first data set, an U2 is the second data set, and on to UU as cycle. To stop counting in cycle mode, let SC to become 0 to end of cycle. For example, sets SC as 0 at U3, and then sets UU to become cycle mode. The tightening would act cycling between U1 and U2.	U1
SC	0-99	Counting number / count-down only ; The tightening process will not count if SC sets as 0 at U1 and screws displayed as 00.	not cycle count if SC sets as 0 at U1	05
At	0.0-9.9	OKALL Signal output time	---	1.0
RC	0.0-9.9	Slow start time	When RC=0 or SP=L0 the slow start function could not work.	0.0
SP	L0~L9	Slow start RPM level L0:100%, L1~L9 (10%~90%) Rated speed.		L0
Ht	0.1-9.9	Ht time Stop time (Show wrong as screwdriver can't stop at set time after starting, can be used to test stripped screws)	Without release trigger from screwdriver the buzz is on continuously and red LED keeps flashing.	2.0
Lt	0.01-9.9	(1) Lo time : An ERROR happens when the time of screwdriver stopped working from started less than the time has set in Lt setting. (2) "02." is displayed as 0.02. To make a change by press P key for adjusting decimal point. It can be modified as 0.2. (3) The Lt value could not greater than Ht during setting. So, the system will change Lt in 0.1 less than Ht. automatically.	Three buzz and LED red flash	0.00
LL	0.01-9.9	Reconfirm time after fastening. (1) Reconfirm setting time after fastening. (2) "02." is displayed as 0.02. To make a change by press P key for adjusting decimal point. It can be modified as 0.2. (3) There will output an OK signal after time up in LL, and green LED will be on.	Rt & LL setting values could not coexist. So, either make Rt or LL setting alone only.	0.00
Ns	Y or N	Ns : Set the function of stopping the screwdriver when any error message occurs. Y: Stop the screwdriver when any error occurred meanwhile, Reverse is OK; Restore by pressing "S" button Forward locking. N: screwdriver could operate continually when any error occurred.	LCD displays NS" NsHt: 4 beeps NsLt: 3 beeps Red LED is always on	N
Rn	Y or N	Rn : Set the count-up mode for the reversion. Y:taken in count for each reversion ; N:Only count once when reverse, OF: Reversing but no counting down.	---	N
Rt	0.01 - 9.99	(1) Rt : Set auto reverse time after the screwdriver shutting off. (2) "02." is displayed as 0.02. To make a change by press P key for adjusting decimal point. It can be modified as 0.2.	Rt & LL setting values could not coexist. So, either make Rt or LL setting alone only.	0.00

※SELECT (P+UP Enter into Menu) Sr Key

Function Name	Set up Time and Value	Description	Buzz Time/ Light	Factory default settings
Sr	Y or N	OKALL display mode _Y: Small loop ; N: Big loop	---	N

※ Auto learning mode “Ln” (S+P Enter into Menu) SL=SC=At=RC=SP=Ht=P Key

Function Name	Set up Time and Value	Description	Buzz Time/ Light	Factory default settings
SL	U1~UU	Screw List	Select UP/DOWN to change value and then press S to confirm.	U1
SC	0~99	Counting number / count-down only	Select UP/DOWN to change value and then press S to confirm.	05
At	0.0~9.9	OKALL signal and time displayed.	Select UP/DOWN to change value and then press S to confirm.	1.0
RC	0.0~9.9	Slow start time	Select UP/DOWN to change value and then press S to confirm.	0.0
SP	L0~L9	Slow start RPM level L0:100%, L1~L9 (10%~90%) Rated speed.	Select UP/DOWN to change value and then press S to confirm.	L0
Ht	0.1~9.9	Ht time Stop time (Show wrong as screwdriver can't stop at set time after starting, can be used to test stripped screws)	A LED starts flashing as we entered “0.0”. To return to normal working status, needs to escape brake from screwdriver and let screwdriver automatic to record time of lock. And then press P key to save it.	0.0

※LCD Keypad lock/ unlock function (S+UP)

Function Name	Set up Time and Value	Description	Buzz Time/ Light	Factory default settings
LC	---	Keypad LOCK P/S/R button	---	---
UN	---	UNLOCK	---	---

※ Alarm Settings (UP+DOWN)

Function Name	Set up Time and Value	Description	Buzz Time/ Light	Factory default settings
ON	---	When OK, OKALL, or NG happens the alarm will be on to warn operators.	---	---
OFF	---	When NG happens, the alarm will be on to warn operators.	---	---
FF	---	When OKALL or NG happens, the alarm will be on to warn operators.	---	---
EF	---	When OK or OKALL happens, the alarm will be on to warn operators.	---	---

※ Check Firmware & Hardware version (Press and hold DOWN key then press P key)
Name on category F/W version Description Remark Factory setting

Category	Version	Description	Remark	Factory Setting
CCD board	F/W ver.	For example: When panel displays “1.0” the final display would be like “1.000” if “00” comes after press P key. When panel displays “S0” by press DOWN key the final display would be like “S000” if “00” comes after press P key.	Hint: There will have one digit come after decimal when check CCD board, but non on MCB board.	---
	1.000			
	Special Edition			
MCB board	F/W ver.	For example: When panel displays “1” the final display would be like “1.00” if “00” comes after press P key. When panel displays “S0” by press DOWN key the final display would be like “S000” if “00” comes after press P key.		---
	1.00			
	Special Edition			
	S000			

Disable Counter: Press and hold P key for 5 seconds until all digits were disappeared in the meantime, a LED light is on green.
You may return counter function back to original setting by pressing P key for 3 seconds during counter has been accessing.
Press R key to allow system returning to the factory setting.

- ※SKD-BE PCB has three kinds of signal, OKALL、NG、OK and GATE and is an open collector type.
- ※Output users need input voltage to drive the buzzer, the input voltage can't be over DC24V 10mA.
- ※There is a new judgment which is the screwdriver will judge a N.G.in the case of there is a start signal and it is OFF before Lt.
- ※If operator controls these functions from PLC close short circuit will take 500ms at least.

J5 (EXT) PORT	
NO.	Function
1	OKALL
2	NG
3	OK
4	GATE
5	GND

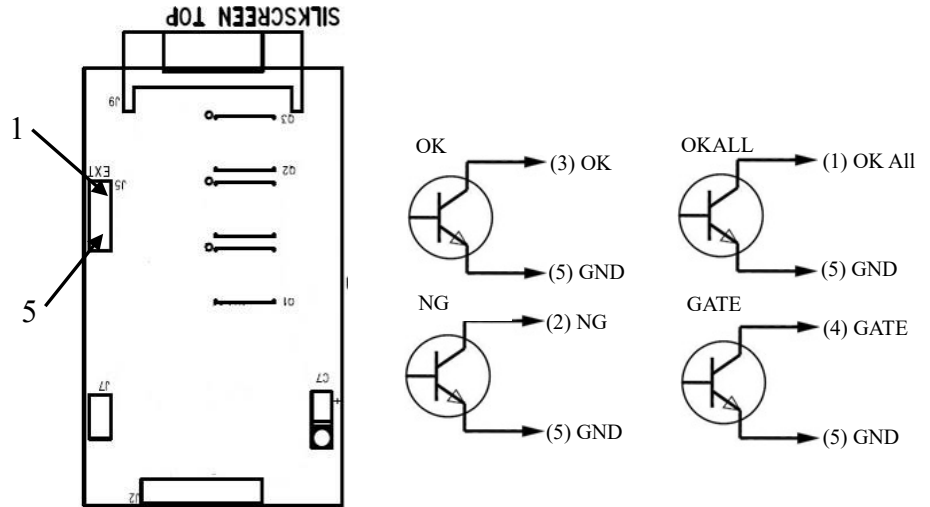

Push both UP + DOWN set up the buzzer :

ON	Fastening a screw, completing work and mistaken operation, buzzer will be on.
OFF	Wrong operation will be buzzed.
FF	Work completed and wrong operation will cause buzz.
EF	As one screw is fastened and work is completed, buzzer will be on; as mistake made has no buzz.

Ht/Lt Description:

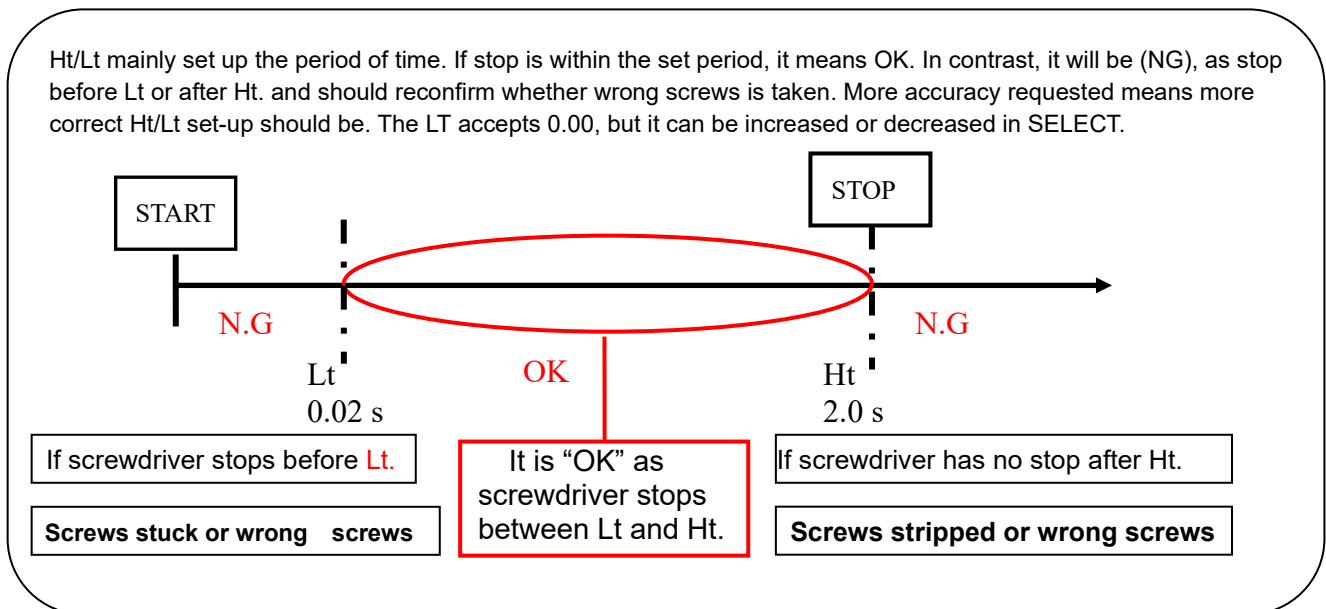

※To shut down the count: If count needs be shut down, push P key for five seconds until no figures on the panel, meanwhile LED 1 will show green light.

※If set value need be reset during counting, just push three seconds.

※Simulate-learning: as electric screwdriver is not used, push S key and then push P key to enter simulate-learning procedure.

SL(S)===SC(S)===At(S)=== Test Data===(P)

- 1) Show SL (Screw List), select UP/DOWN to change number and then push S(confirm)
- 2) Show SC (counting number), select UP/DOWN to change number and then push S(confirm)
- 3) Show At (automatic zero), UP/DOWN to change value; then push P (confirm)
- 4) Enter simulate-learning (LED 1 will keep flash)
- 5) When recording value, push P key and back working condition.

※LED light flash in simulate-learning.(means under simulate- learning condition), push P key to record value after simulate -learning.)

※ As no use of screwdrivers: UP and push P key can set up waiting time.

If three seconds are set, but no starting signal after set time, it will buzz.

※Push R key to restore to factory settings.

General execution of pre-set program:

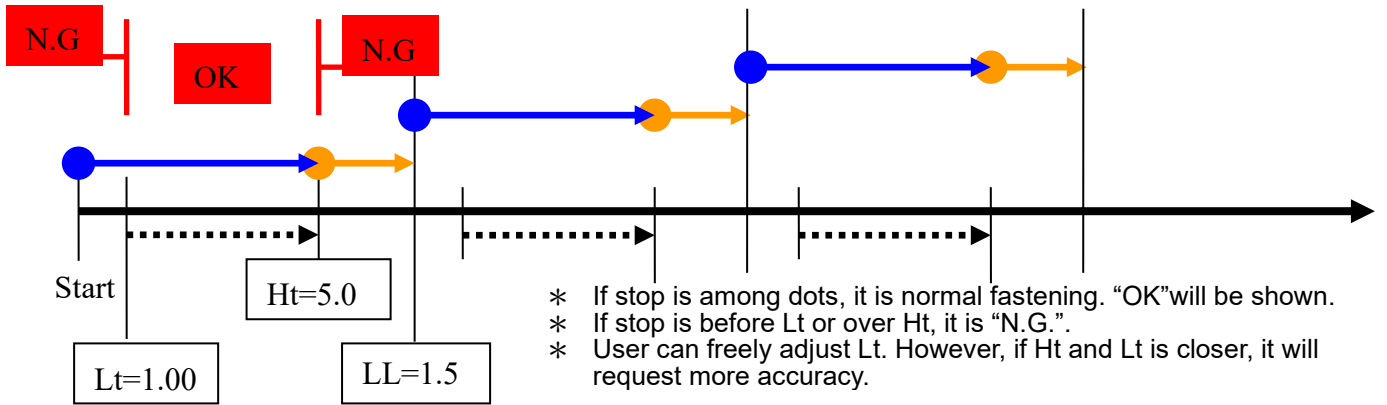

Torque Adjustment Operation

To adjust the torque on these screwdrivers. Proceed as follows :

1. Determine the torque output of the tool by checking a tightened Fastener with a torque wrench.
2. Increase or decrease the torque by rotating the Spring Adjusting Ring. Rotating the Ring clockwise to a higher number on the torque Scale increase torque output while rotating the Ring counterclockwise to a lower number decreases the torque output.
3. Check the adjustment with a torque wrench. A number of factors will affect torque output from one job to another. Final torque adjustment should be made at the job through a series of gradual increase. Always start below the desired torque and work upward.
4. Adjust the bit torque by changing the driving in length of the adjust ring at the end.
5. The relationship between torque scale and bit torque is as shown Ring, in the torque diagram. The figures of torque scale do not indicate bit torque values. However, the clamping torque of screw itself is different form type, size, material of the screw and the material of its mating part. Use it as standard to obtain an appropriate clamping torque.
6. The (Return torque method) in which once-clamped screw is returned with torque wrench or the like is available as one of torque control methods, however, note that the measured values by the return torque method generally appear in 10%~30% lower than the actually clamping torque.
7. The torque checker measures the torque of screwdriver. The clamping torque of screw itself is different from the clamped conditions. Understand the correlation between clamping torque values and the torque checker values perform the torque control properly.

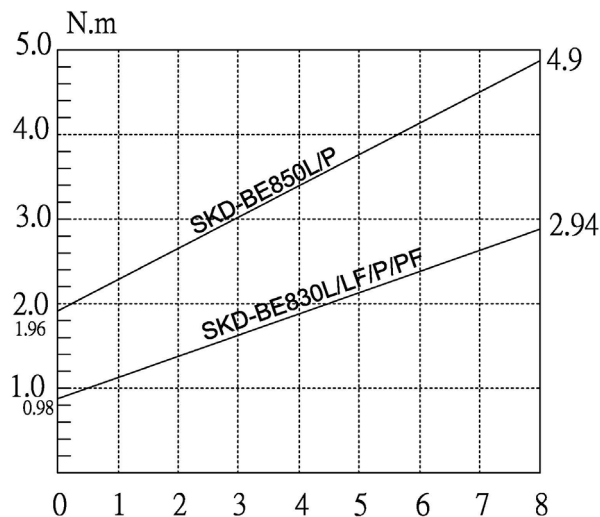

CAUTION

1. Also in reverse rotation, the clutch is turned off in such manner as in normal rotation, stopping the motor running. Accordingly, when the screw tightened at a large torque, set it to a higher torque scale.
2. The number from zero to eight on the Torque Scale is reference number only and not an indication of actual torque output.
3. The power supplier will generate low power when the button of the power controller is switched to "LO." Also, the electric screwdriver's torque output setting value should be adjusted to middle torsion value accordingly.
4. The mechanical wear condition of the electric screwdriver depends on the torque, duration, and the frequency that user used. In the case of using greater torque, the higher frequency and the longer operation, the screwdriver will get worn faster. The new screwdriver uses in the scale of 4 for one month (frequency: 12 pcs/ min; 8 hours / per day) will result in 3% ~ 5% torque decay. (Scale of 8 will result in 5% ~ 7% torque decay). By the growth in use of time, the torque decay level will gradually reduce and stabilize. User could test the torque output of the screwdriver by torque meter periodically and then adjust it to meet user's requirement for the compensation of the torque decay.
5. Please refer to KILEWS website <http://www.kilews.com> for the detail component list.

Our company reserves the right to modify the product without prior notice.