

Specifications

MODEL	SK-205LS	SK-215LS	SK-218LS	SK-2205LS	SK-2215LS	
Input Voltage	AC110V~120V 50HZ/60HZ			AC220V~240V 50HZ/60HZ		
Rated input	48W					
Bit torque	(kgf.cm)	0.5~7	2~15	3~18	0.5~7	2~15
	(Lbf.in)	0.44~ 6.10	1.77~13.00	2.57~15.58	0.44~ 6.10	1.77~13.00
	(N.m)	0.05 ~0.69	0.2~1.47	0.29~1.76	0.05 ~0.69	0.2~1.47
Rev speed at no load	RPM	1200	1200	1000	1000	1000
Torque Accuracy (%)	±5%					
Torque Adjustment	Step less					
Unloaded power Consumption (A)	0.3A	0.3A	0.3A	0.2A	0.2A	
Metal assembly screw Dia(mm)	Machine screw	1.6~3.0	2.0~4.0	2.0~4.0	1.6~3.0	2.0~4.0
	Tapping screw	1.4~2.0	2.0~3.0	2.0~3.0	1.4~2.0	2.0~3.0
Weight (g)	480					
Length (mm)	230					
Model of Torque Fixing Ring	KC-3					
Model of Suspension Rack	KH-2					
Bit Type	 HEX 5mm, HEX 6.35mm Ø4mm, Ø5mm					

* Please use torque meter "KTM-15" to test the low torque range of SK-205LS and SK-2205LS

* 1N.m=10.2Kgf.cm 1N.m=8.85Lbf.in

Accessories

1. BIT Type :
 - NO. 0# Bit for screw dia. 1.8~ 2.0mm
 - NO. 1# Bit for screw dia. 2.0~ 2.6mm
 - NO. 2# Bit for screw dia. 3.0~ 3.5mm

SK-205LS : SK-2205LS with BIT 0# & 1# 1 pcs. Each

SK-215LS : SK-2215LS ; SK-218LS with BIT 1# & 2# 1 pcs. Each

2. Spring (Length: 30cm) 1 pcs.

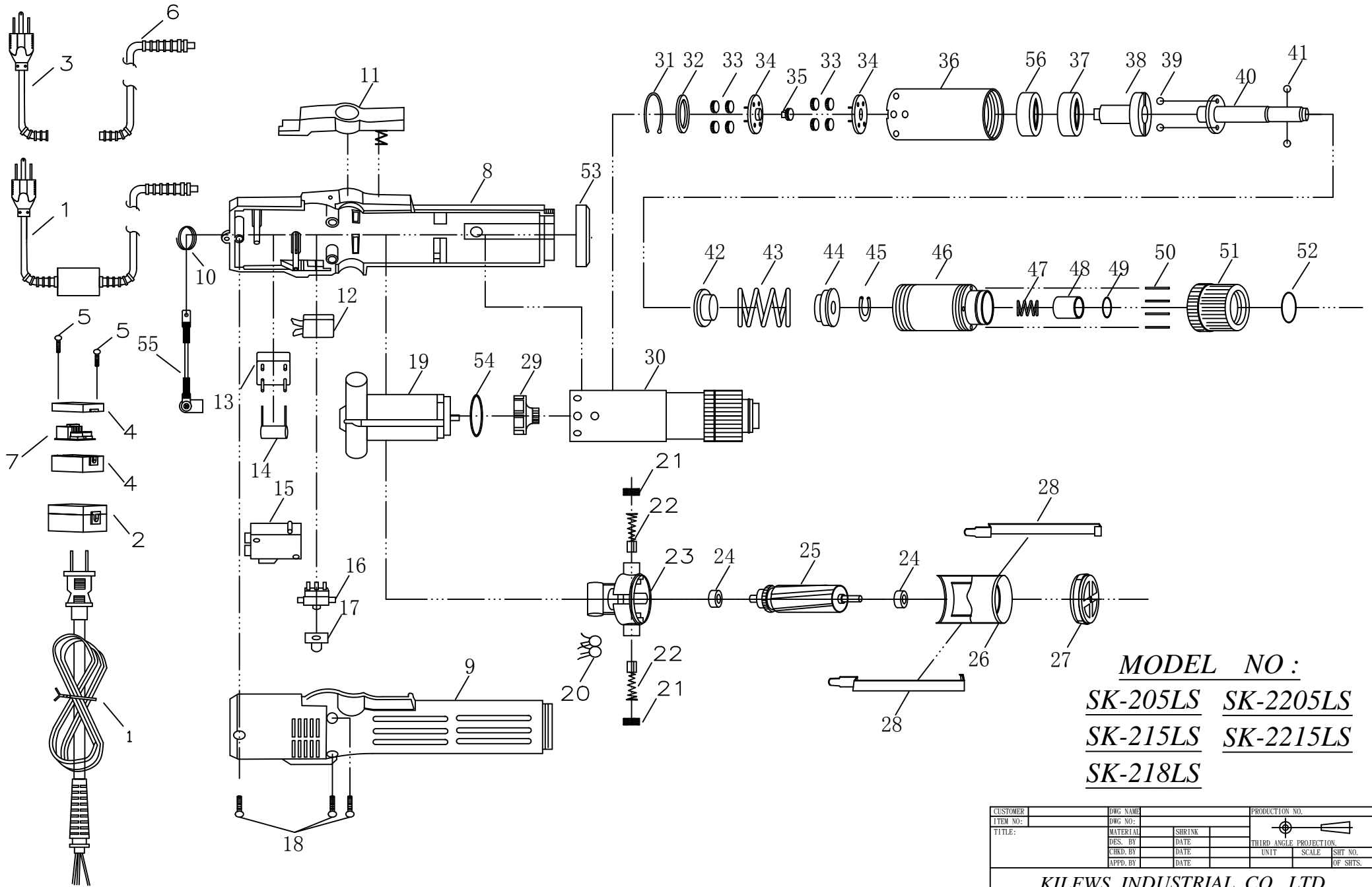

MODEL NO :
SK-205LS SK-2205LS
SK-215LS SK-2215LS
SK-218LS

CUSTOMER	DWG NAME	PRODUCTION NO.		
ITEM NO:	DWG NO:			
TITLE:	MATERIAL	SHRINK		
	DES. BY	DATE	UNIT	SCALE
	CHKD. BY	DATE	SCALE	SHT NO.
	APPD. BY	DATE		OF SHTS.

KILEWS INDUSTRIAL CO., LTD.

No	PARTS NO	PARTS NAME-E	PARTS NAME-C	Qty	No	PARTS NO	PARTS NAME-E	PARTS NAME-C	Qty
1	AA20001	CORD 10FT-110V	電源線整組 平插10FT-110V	1	29	MK20131-1	FAN-110V	風扇連主齒-110V	1
	A10102	CORD American 10FT-110V	電源線整組 美規10FT-110V	1		MK33091	FAN-220V	風扇連主齒-220V	1
	A10104	CORD UK 10FT-110V	電源線整組 英規10FT-110V	1	30	GZ22141-1A	CLUTCH ASSY-205LA	離合器整組-205LA	1
	AD30001-A	CORD American-CE Box	電源線整組 美規-CE盒	1		GZ22141-1B	CLUTCH ASSY-205LB	離合器整組-205LB	1
	AD30001-D	CORD Australia-CE Box	電源線整組 澳規-CE盒	1		GZ22141-1C	CLUTCH ASSY-205LC	離合器整組-205LC	1
	AD30001-F	CORD Europe-CE Box	電源線整組 歐規-CE盒	1		GZ22141-1D	CLUTCH ASSY-205LD	離合器整組-205LD	1
	AA30001-G	CORD UK-CE Box	電源線整組 英規-CE盒	1		GZ22141-1DA	CLUTCH ASSY-205LAD	離合器整組-205LAD	1
	AD30001-J	CORD India-CE Box	電源線整組 印規-CE盒	1		GZ22141-2A	CLUTCH ASSY-215LA	離合器整組-215LA	1
2	EJ30002-3	CE Box Ass'y	CE盒成品	1		GZ22141-2B	CLUTCH ASSY-215LB	離合器整組-215LB	1
3	AA30007-1	CORD American 1Ft-CE Box	電源線美規 1呎-CE盒	1		GZ22141-2C	CLUTCH ASSY-215LC	離合器整組-215LC	1
	AA30007-1D	CORD Australia 1Ft-CE Box	電源線澳規 1呎-CE盒	1		GZ22141-2D	CLUTCH ASSY-215LD	離合器整組-215LD	1
	AA30007-2	CORD Europe 1Ft-CE Box	電源線歐規 1呎-CE盒	1		GZ22141-2AD	CLUTCH ASSY-215LAD	離合器整組-215LAD	1
	AA30007-5	CORD UK 1Ft-CE Box	電源線英規 1呎-CE盒	1		GZ20141-3A	CLUTCH ASSY-218LA	離合器整組-218LA	1
	AA30007-5E	CORD India 1Ft-CE Box	電源線印規 1呎-CE盒	1		GZ20141-3B	CLUTCH ASSY-218LB	離合器整組-218LB	1
4	EC30006	EMC-BOX CASE ONLY-CE Box	EMC盒上下蓋-CE盒	1		GZ20141-3AD	CLUTCH ASSY-218LAD	離合器整組-218LAD	1
5	CH90152-1F	SCREW-CE Box	螺絲 -CE盒	2	31	GK20231-1	"C" RING	齒輪固定C環	1
6	AA30009-3T	CORD 9Ft-CE Box	9呎電源線-CE盒	1	32	GI20251-1	IRON WASHER	齒輪固定片	1
7	EG30005-4	PCB-CE Box	PC板-CE盒	1	33	GH20241	GEAR PLANET	游星齒輪	8
8	CB20021	HOUSING UNDERSIDE-110V	外殼下蓋-110V	1	34	GG20271	GEAR SEAT	齒盤	2
	CB22021	HOUSING UNDERSIDE-220V	外殼下蓋-220V	1	35	G20101	GEAR OF CENTER	中心齒	1
9	CA20101	HOUSING UPSIDE-110V	外殼上蓋-110V	1	36	GA30311-5	GEAR CASE	上筒	1
	CA22101	HOUSING UPSIDE-220V	外殼上蓋-220V	1	37	GN30321	MAIN BEARING	離合器主軸承	1
10	CI20011	SUSPENSION RING	起子吊環	1	38	GC20301	CAM	上離合器頭	1
11	CC20031	TRIGGER	手按開關桿	1	39	GP30351	STEEL BALL-4MM	跳脫鋼珠-4mm	2
12	CF20061	BREAKER-110V	保護器-110V	1	40	GD30381A	SHAFT A-TYPE	傳動軸-A頭	1
13	E31203-1	BIRDGE DIODE	橋式整流器	1		GD20321-3	SHAFT B-TYPE	傳動軸-B頭	1
14	E30206	CAPACITOR-110V	電容器-110V	1		GD20321-2	SHAFT C-TYPE	傳動軸-C頭	1
15	HB50071	START SWITCH	啟動開關半成品	1		GD20321-1	SHAFT D-TYPE	傳動軸-D頭	1
16	HA15091F	CHANGEVER SWITCH	正反開關	1		GD20321	SHAFT AD-TYPE	傳動軸-AD頭	1
17	CI33211-2	SWITCH CAP-205L	正反開關帽蓋-205L	1	41	GP20331	STEEL BALLS FOR "A&D" TYPE	起子頭帽鋼珠(A&D用)	2
	CI30211	SWITCH CAP-215L	正反開關帽蓋-215L	1		GP21291B	STEEL BALLS FOR "B&C" TYPE	起子頭帽鋼珠(B&C用)	2
	CI33211-3	SWITCH CAP-218L	正反開關帽蓋-218L	1	42	GF20341	WARRING PLATE FOR A,C,D TYPE	扭力推盤(A,C,D)	1
	CI33211-1	SWITCH CAP-2205L	正反開關帽蓋-2205L	1		GF20341B	WARRING PLATE FOR B TYPE	扭力推盤(B)	1
	CI30212	SWITCH CAP-2215L	正反開關帽蓋-2215L	1	43	GE20351-1	WARRING SPRING FOR 205L	扭力彈簧 205L	1
18	CH20102	SCREW	螺絲	3		GE20350-1	WARRING SPRING FOR 215L	扭力彈簧 215L	1
19	MO20121-2	MOTOR ASSEMBLY-205L/215L	馬達整組-205L/215L	1		GE30411-3	WARRING SPRING FOR 218L	扭力彈簧 218L	1
	MO20121-1	MOTOR ASSEMBLY-218L	馬達整組 218L	1	44	GY30421	WARRING SPRING BASE FOR A,C,D	止推盤 (A,C,D)	1
	MO22121	MOTOR ASSEMBLY-220V	馬達整組-220V	1		GY30421B	WARRING SPRING BASE FOR B TYPE	止推盤 (B)	1
20	EB33610-2	CERAMICS CAPACITOR-110V	陶瓷電容-110V	1	45	GK20231B	C-RING FOR B TYPE	傳動軸固定C環(B)	1
21	MD20151	BRUSH CAP	碳刷蓋	2	46	GB30441-10	CLUTCH CASE FOR A,C,D TYPE	下離合器筒(A,C,D)	1
22	MC20161	CARBON	碳刷	2		GB30441-7A	CLUTCH CASE FOR B TYPE	下離合器筒(B)	1
23	ML20171	MOTOR TOP COVER-110V	碳刷座-110V	1	47	GO30452	BIT SPRING FOR A,C,D TYPE	起子頭彈簧(A,C,D)	1
	ML33571	MOTOR TOP COVER-220V	碳刷座-220V	1		GO20391B	BIT SPRING FOR B TYPE	起子頭彈簧(B)	1
24	ME20181	ARMATURE BEARING-110V	軸承-110V	2	48	GJ30461	BIT SLEEVE FOR A,C,D TYPE	起子頭帽(A,C,D)	1
	ME21481	ARMATURE BEARING-220V	軸承-220V	2		GJ3046B	BIT SLEEVE FOR B TYPE	起子頭帽(B)	1
25	MH20191	ARMATURE-205L/215L	電樞-205L/215L	1	49	GQ30471	"C" RING FOR A,C,D TYPE	起子頭帽C環(A,C,D)	1
	MH20191-1	ARMATURE-218L	電樞-218L	1		GQ21361	"C" RING FOR B TYPE	起子頭帽C環(B)	1
	MH23601	ARMATURE-2205L/2215L	電樞-2205L/2215L	1	50	GL30481-1	TORQUE ADJ PINS	扭力調整棒	4
26	MJ20201	MOTOR YORK ASSEMBLY-205L/215L	馬達鐵圈連磁鐵-205L/215L	1	51	GM20431-1	TORQUE ADJ RING	扭力調整環	1
	MJ30631	MOTOR YORK ASSEMBLY-218L	馬達鐵圈連磁鐵-218L	1	52	GS30501	"C" RING FOR GM21381	扭力環C環	1
	MJ33631	MOTOR YORK ASSEMBLY-2205L/2215L	馬達鐵圈連磁鐵-2205L/2215L	1	53	CD20111	COUPLER	前鎖環	1
27	MB20221	MOTOR END COVER-110V	馬達前蓋-110V	1	54	MF30101	INSULATING WASHER-220V	絕緣墊圈-220V	1
	MB33651A	MOTOR END COVER-220V	馬達前蓋-220V	1	55	P12104	3cm RETAINING CLIP	三分固定線	1
28	MA20211B	ASSEMBLY SPRING-110V	馬達固定鐵片-110V	2	56	GN30435	MAIN BEARING	離合器主軸承	1
	MA33621A	ASSEMBLY SPRING-220V	馬達固定鐵片-220V	2					

Torque Adjustment Operation

To adjust the torque on these screwdrivers. Proceed as follows :

1. Determine the torque output of the tool by checking a tightened Fastener with a torque wrench.
2. Increase or decrease the torque by rotating the Spring Adjusting Ring. Rotating the Ring clockwise to a higher number on the torque Scale increase torque output while rotating the Ring counterclockwise to a lower number decreases the torque output.
3. Check the adjustment with a torque wrench. A number of factors will affect torque output from one job to another. Final torque adjustment should be made at the job through a of series of gradual increase. Always start below the desired torque and work upward.
4. Adjust the bit torque by changing the driving in length of the adjust ring at the end.
5. The relationship between torque scale and bit torque is as shown Ring, in the torque diagram. The figures of torque scale do not indicate bit torque values. However, the clamping torque of screw itself is different form type, size, material of the screw and the material of its mating part. Use it as standard to obtain an appropriate clamping torque.
6. The (Return torque method) in which once-clamped screw is returned with torque wrench or the like is available as one of torque control methods however, note that the measured values by the return torque method generally appear in 10%~30% lower than the actually clamping torque.
7. The torque checker measures the torque of screwdriver. The clamping torque of screw itself is different from the clamped conditions. Understand the correlation between clamping torque values and the torque checker values perform the torque control properly.

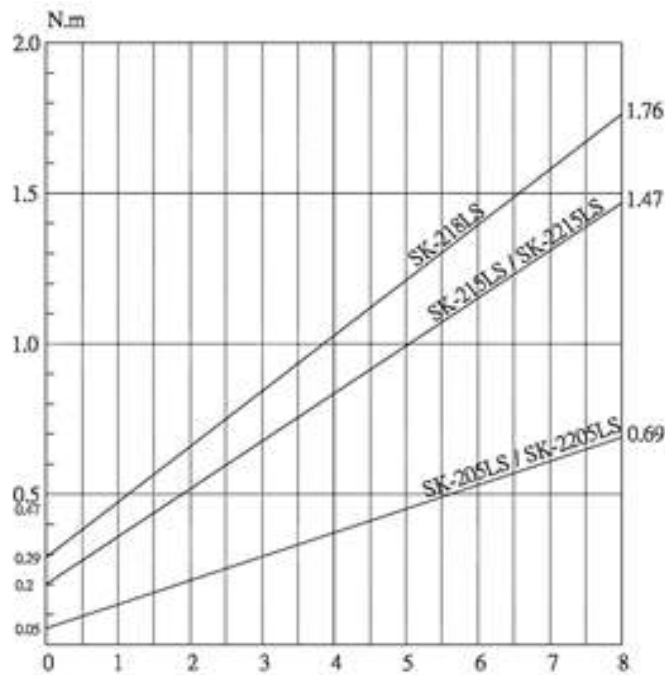

CAUTION

1. Also in reverse rotation, the clutch is turned off in such manner as in normal rotation, stopping the motor running. Accordingly, when the screw tightened at a large torque, set it to a higher torque scale.
2. The number from zero to eight on the Torque Scale are reference number only and not an indication of actual torque output.

RoHS

Equipment name: Electric screwdriver						
Type designation (Type): SK-205LS,SK-215LS,SK-218LS						
Unit	Restricted substances and its chemical symbols					
	Lead (Pb)	Mercury (Hg)	Cadmium (Cd)	Hexavalent chromium (Cr ⁺⁶)	Polybrominated biphenyls (PBB)	Polybrominated diphenyl ethers (PBDE)
Housing	○	○	○	○	○	○
Switch line	○	○	○	○	○	○
MOTOR ASSEMBLY	○	○	○	○	○	○
Gear Housing	○	○	○	○	○	○
CORD ASSEMBLY	○	○	○	○	○	○
<p>Note 1 : “Exceeding 0.1 wt %” and “exceeding 0.01 wt %” indicate that the percentage content of the restricted substance exceeds the reference percentage value of presence condition.</p> <p>Note 2 : “○” indicates that the percentage content of the restricted substance does not exceed the percentage of reference value of presence.</p> <p>Note 3 : The “-” indicates that the restricted substance corresponds to the exemption.</p>						



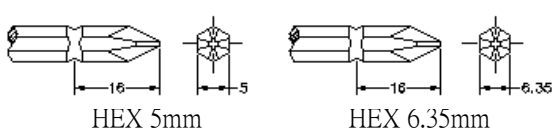

Specifications

MODEL		SK-2125LS	SK-2135LS	SK-2145LS	SK-2125LSF	SK-2225LS	SK-2235LS	SK-2245LS	SK-2225LSF
Input Voltage		AC110V~120V 50HZ/60HZ				AC220V~240V 50HZ/60HZ			
Rated input		48W				55W			
Bit torque	(kgf.cm)	5~25	10~35	15~45	5~18	5~25	10~35	15~45	5~18
	(Lbf.in)	4.34~21.68	8.67~30.35	13~39.02	4.34~15.58	4.34~21.68	8.67~30.35	13~39.02	4.34~15.58
	(N.m)	0.49~2.45	0.98~3.43	1.47~4.41	0.49~1.76	0.49~2.45	0.98~3.43	1.47~4.41	0.49~1.76
Rev speed at no load	RPM	1000	830	550	2000	1000	700	500	2000
Unloaded power Consumption (A)		0.3A	0.3A	0.3A	0.3A	0.2A	0.2A	0.2A	0.2A
Torque Accuracy (%)		±5%							
Torque Adjustment		Step less							
Metal assembly screw Dia(mm)	Machine screw	2.6~5.0	2.6~5.0	3.0~6.0	2.0~4.0	2.6~5.0	2.6~5.0	3.0~6.0	2.0~4.0
	Tapping screw	2.6~4.0	2.6~4.0	3.0~5.0	2.0~3.5	2.6~4.0	2.6~4.0	3.0~5.0	2.0~3.5
Weight (g)		600							
Length (mm)		264							
Model of Torque Fixing Ring		KC-2							
Model of Suspension Rack		KH-1							
Bit Type									

* 1N.m=10.2Kgf.cm 1N.m=8.85Lbf.in

Accessories

1. BIT Type :
- NO. 0# Bit for screw dia. 1.8~ 2.0mm
 - NO. 1# Bit for screw dia. 2.0~ 2.6mm
 - NO. 2# Bit for screw dia. 3.0~ 3.5mm

SK-2125LS	: SK-2225LS	with BIT 1# & 2# 1 Pcs. Each
SK-2135LS	: SK-2235LS	with BIT 2# 2 pcs.
SK-2145LS	: SK-2245LS	with BIT 2# 2 pcs.
SK-2125LSF	: SK-2225LSF	with BIT 1# & 2# 1 Pcs. Each

2. Spring (Length: 30cm) 1 pcs.

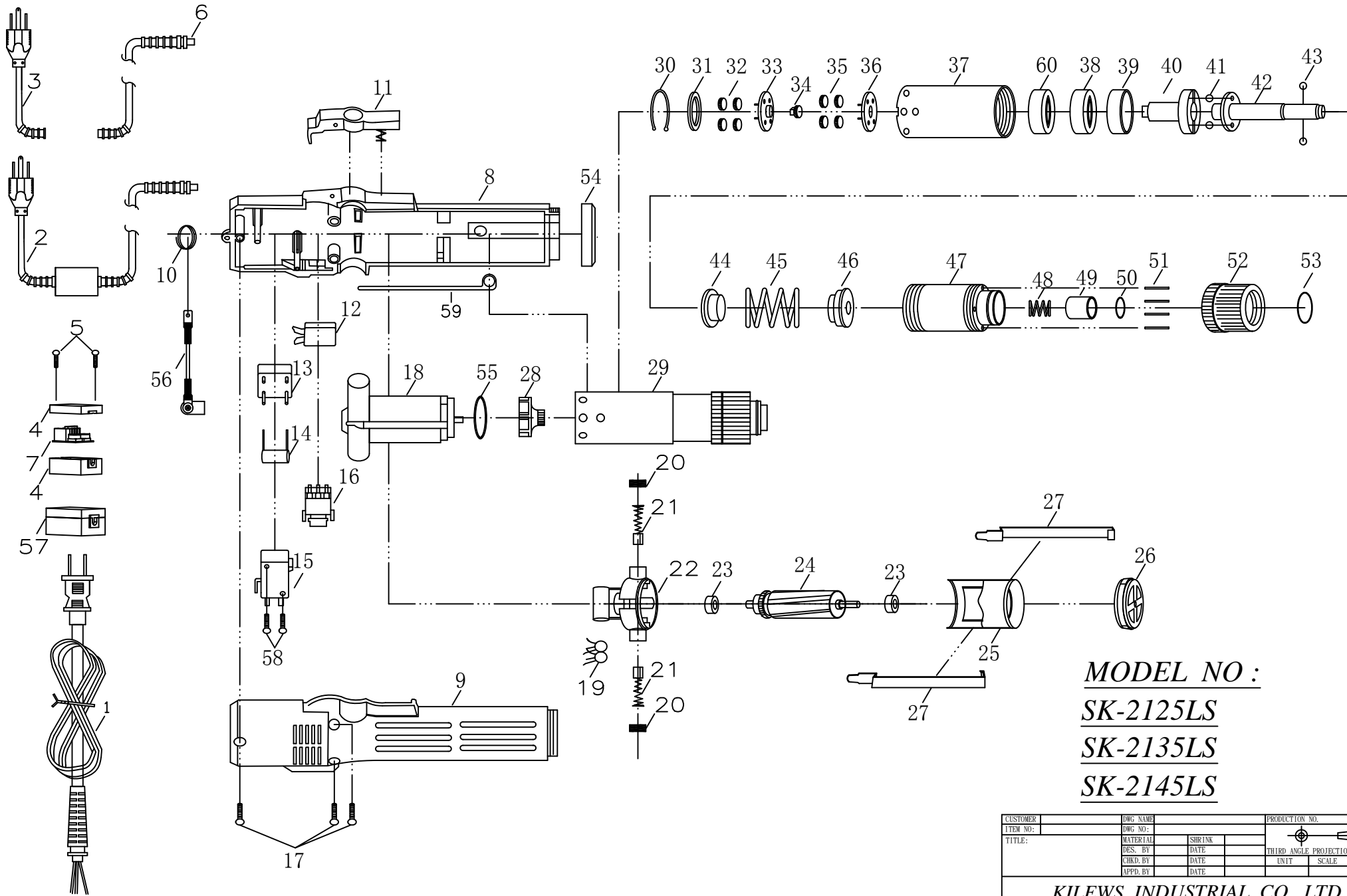

MODEL NO :
SK-2125LS
SK-2135LS
SK-2145LS

CUSTOMER	DWG NAME	PRODUCTION NO.	
ITEM NO:	DWG NO:		
TITLE:	MATERIAL	SHRINK	THIRD ANGLE PROJECTION
	DES. BY	DATE	UNIT
	CHKD. BY	DATE	SCALE
	APPD. BY	DATE	OF SHTS.

KILEWS INDUSTRIAL CO., LTD.

No.	PARTS NO.	PARTS NAME-E	PARTS NAME-C	Q'ty	No.	PARTS NO.	PARTS NAME-E	PARTS NAME-C	Q'ty
1	AA20001	CORD	電源線整組 平插	1		GZ21145AD	CLUTCH ASSY 2145LA	離合器整組 2145LAD	1
2	AD30001-A	CORD American	電源線整組 美規	1		GZ21145B	CLUTCH ASSY 2145LB	離合器整組 2145LB	1
	AD30001-D	CORD Australia	電源線整組 澳規	1	30	GK21181	"C" RING	齒輪固定C環	1
	AD30001-F	CORD Europe	電源線整組 歐規	1	31	GI21191	IRON WASHER	齒輪固定片	1
	AA30001-G	CORD UK	電源線整組 英規	1	32	GH20241	GEAR PLANET FOR 2125L	游星齒輪 2125L	3
	AD30001-J	CORD India	電源線整組 印規	1		GH91232	GEAR PLANET FOR 2135L	游星齒輪 2135L	3
3	AA30007-1	CORD American 1Ft	電源線美規 1呎	1		GH92231	GEAR PLANET FOR 2145L	游星齒輪 2145L	4
	AA30007-1D	CORD Australia 1Ft	電源線澳規 1呎	1	33	GG21231	GEAR SEAT FOR 2125L	上齒盤 2125L	1
	AA30007-2	CORD Europe 1Ft	電源線歐規 1呎	1		GG91242-1	GEAR SEAT FOR 2135L	上齒盤 2135L	1
	AA30007-5	CORD UK 1Ft	電源線英規 1呎	1		GG92241-1	GEAR SEAT FOR 2145L	上齒盤 2145L	1
	AA30007-5E	CORD India 1Ft	電源線印規 1呎	1	34	G20102	GEAR OF CENTER FOR 2125L	中心齒 2125L	1
4	EC30006	EMC-BOX CASE ONLY	EMC盒上下蓋	1	35	GH20241	GEAR PLANET FOR 2125L	游星齒輪 2125L	3
5	CH90152-1F	SCREW	螺絲	2		GH91232-1	GEAR PLANET FOR 2135L	游星齒輪 2135L	3
6	AA30009-1T	CORD 9FT	9呎電源線	1		GH92231-1	GEAR PLANET FOR 2145L	游星齒輪 2145L	4
7	EG30005-4F	PCB	PC板-EMC	1	36	GG21231	GEAR SEAT FOR 2125L	下齒盤 2125L	1
8	CB21041	HOUSING UNDERSIDE	外殼下蓋	1		GG91272-1	GEAR SEAT FOR 2135L	下齒盤 2135L	1
9	CA21161	HOUSING UPSIDE	外殼上蓋	1		GG92271-1	GEAR SEAT FOR 2145L	下齒盤 2145L	1
10	CJ20011	SUSPENSION RING	起子吊環	1	37	GA21241	GEAR CASE FOR 2125L	上筒 2125L	1
11	CC21011	TRIGGER	手按開關桿	1		GA35241	GEAR CASE FOR 2135L 2145L	上筒 2135L 2145L	1
12	CF20061	BREAKER	保護器	1	38	GN21251	MAIN BEARING	離合器主軸承	1
13	E31203-1	BIRDGE DIODE	橋式整流器	1	39	GW21531	IRON RING	鐵墊圈	1
14	E30207	CAPACITOR	電容器	1	40	GC31321	CAM	上離合器頭	1
15	HB50072	START SWITCH	啟動開關半成品	1	41	GP30351	STEEL BALL-4MM	跳脫鋼珠-4mm	2
16	HA21151	CHANGEOVER SWITCH-2125L	正反開關-2125L	1	42	GD21281A	SHAFT-5MM HEX	傳動軸-A頭	1
	HA91042	CHANGEOVER SWITCH-2135L	正反開關-2135L	1		GD21281AD	SHAFT FOR "AD" TYPE	傳動軸(AD頭)	1
	HA92051	CHANGEOVER SWITCH-2145L	正反開關-2145L	1		GD21281B	SHAFT-6.35MM HEX	傳動軸-B頭	1
17	CH20102	SCREW	螺絲	3	43	GP21291A	STEEL BALL FOR LA	起子頭鋼珠 LA	2
18	MO22091	MOTOR ASSEMBLY FOR 2125L	馬達整組 2125L	1		GP21291B	STEEL BALL FOR LB	起子頭鋼珠 LB	2
	MO21092	MOTOR ASSEMBLY FOR 2135L 2145L	馬達整組 2135L 2145L	1	44	GF21301	WARRING PLATE	扭力推盤	1
19	EB33610-2	CERAMICS CAPACITOR	陶瓷電容	1	45	GE21311	WARRING SPRING FOR 2125L	扭力彈簧 2125L	1
20	MD20151	BRUSH CAP	碳刷蓋	2		GE35311	WARRING SPRING FOR 2135L	扭力彈簧 2135L	1
21	MC21411	CARBON	碳刷	2		GE92382-3	WARRING SPRING FOR 2145LA&LAD	扭力彈簧 2145LA&LAD	1
22	ML21421	MOTOR TOP COVER	碳刷座半成品	1		GE21314	WARRING SPRING FOR 2145LB	扭力彈簧 2145LB	1
23	ME21481	ARMATURE BEARING	軸承	2	46	GY21321	WARRING SPRING BASE	止推盤	1
24	MH21471	ARMATURE FOR 2125L	電樞 2125L	1	47	GB21331	CLUTCH CASE	下離合器筒	1
	MH21472	ARMATURE FOR 2135L 2145L	電樞 2135L 2145L	1	48	GO21341	BIT SPRING	起子頭彈簧	1
25	MJ90601	MOTOR YORK ASSEMBLY	馬達鐵圈連磁鐵	1	49	GI22351	BIT SLEEVE	起子頭帽	1
26	MB21521A	MOTOR END COVER	馬達前蓋	1	50	GQ21361	"C" RING	起子頭帽C環	1
27	MA21491B	ASSEMBLY SPRING	馬達固定鐵片	2	51	GL21371	TORQUE ADJ PINS	扭力調整棒	4
28	MK21111	FAN FOR 2125L	風扇連主齒 2125L	1	52	GM21381	TORQUE ADJ RING	扭力調整環	1
	MK91091	FAN FOR 2135L	風扇連主齒 2135L	1	53	GS21391	"C" RING	扭力環C環	1
	MK92091	FAN FOR 2145L	風扇連主齒 2145L	1	54	CD21031	COUPLER	前鎖環	1
29	GZ21121A	CLUTCH ASSY 2125LA	離合器整組 2125LA	1	55	MF90061	INSULATING WASHER	墊圈	1
	GZ21121AD	CLUTCH ASSY 2125LAD	離合器整組 2125LAD	1	56	PI2104	3cm RETAINING CLIP	三分公固定線	1
	GZ21121B	CLUTCH ASSY 2125LB	離合器整組 2125LB	1	57	EJ30002-3	CE Box Ass'y	CE盒成品	1
	GZ35121A	CLUTCH ASSY 2135LA	離合器整組 2135LA	1	58	CH30003	SCREW	螺絲	2
	GZ35121B	CLUTCH ASSY 2135LB	離合器整組 2135LB	1	59	CH30671-1	GROUNDING MEANS	接地線	1
	GZ21145A	CLUTCH ASSY 2145LA	離合器整組 2145LA	1	60	GN30442	MAIN BEARING	離合器主軸承	1

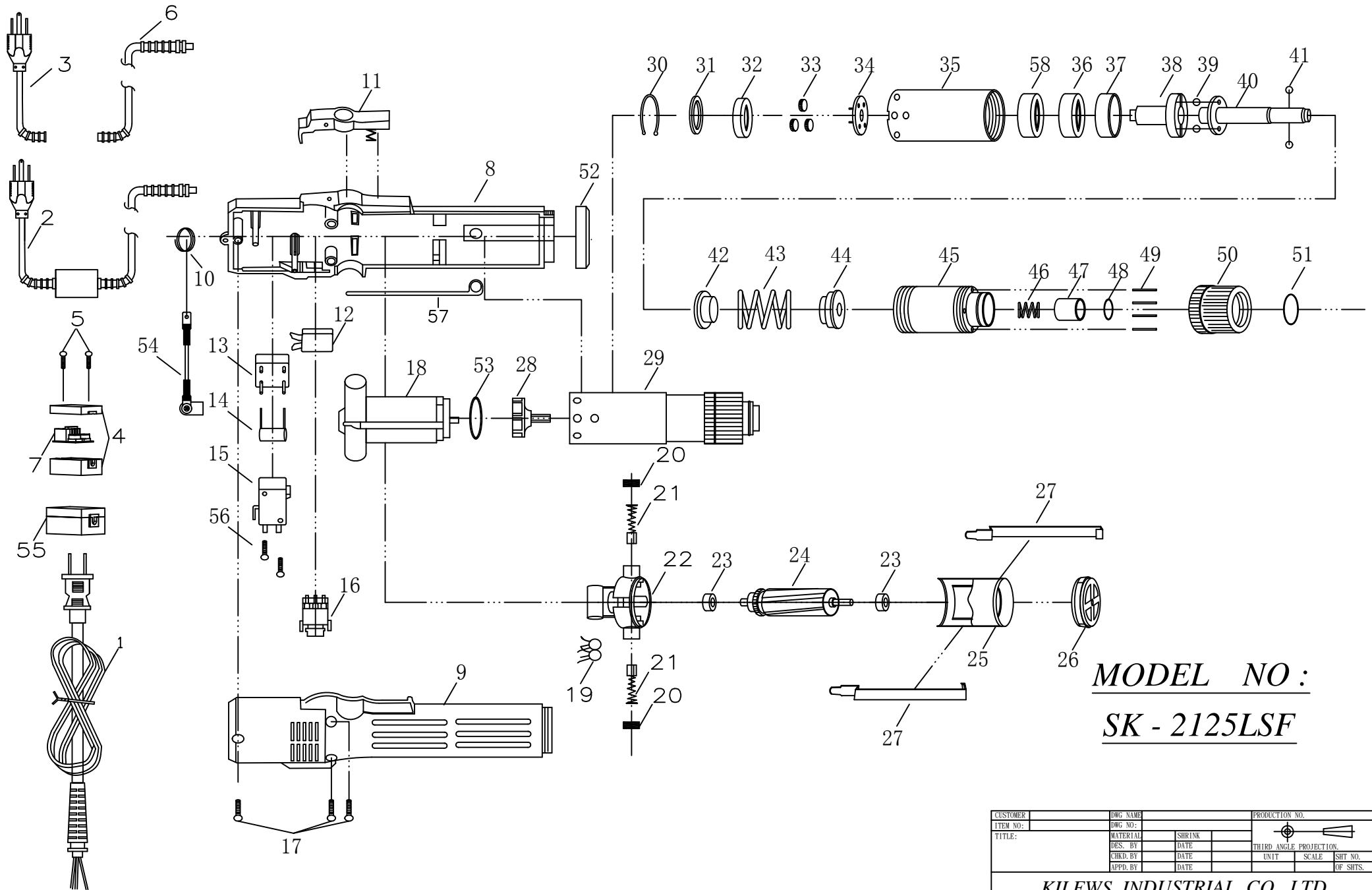

MODEL NO :
SK - 2125LSF

CUSTOMER	DWG NAME	PRODUCTION NO.		
ITEM NO:	DWG NO:			
TITLE:	MATERIAL	SHRINK	THIRD ANGLE PROJECTION	
	DES. BY	DATE	UNIT	SCALE
	CHKD. BY	DATE		SHT NO.
	APPD. BY	DATE		OF SHTS.
KILEWS INDUSTRIAL CO., LTD.				

No.	PARTS NO.	PARTS NAME-E	PARTS NAME-C	Q'ty	No.	PARTS NO.	PARTS NAME-E	PARTS NAME-C	Q'ty
1	AA20001	CORD	電源線整組 平插	1	28	MK21111PF	FAN	風扇連主齒	1
2	AD30001-A	CORD American	電源線整組 美規	1	29	GZ21121AF	CLUTCH ASSY 2125LFA	離合器整組 2125LFA	1
	AD30001-D	CORD Australia	電源線整組 澳規	1		GZ21121BF	CLUTCH ASSY 2125LFB	離合器整組 2125LFB	1
	AD30001-F	CORD Europe	電源線整組 歐規	1	30	GK21181	"C" RING	齒輪固定C環	1
	AA30001-G	CORD UK	電源線整組 英規	1	31	GI21191	IRON WASHER	齒輪固定片	1
	AD30001-J	CORD India	電源線整組 印規	1	32	G21301	WASHER,HIGH SPEED	快速齒輪墊圈	1
3	AA30007-1	CORD American 1Ft	電源線美規 1呎	1	33	GH21221-1	GEAR PLANET	游星齒輪	3
	AA30007-1D	CORD Australia 1Ft	電源線澳規 1呎	1	34	GG21231-1	GEAR SEAT	下齒盤	1
	AA30007-2	CORD Europe 1Ft	電源線歐規 1呎	1	35	GA21241	GEAR CASE	上筒	1
	AA30007-5	CORD UK 1Ft	電源線英規 1呎	1	36	GN21251	MAIN BEARING	離合器主軸承	1
	AA30007-5E	CORD India 1Ft	電源線印規 1呎	1	37	GW21531	IRON RING	鐵墊圈	1
4	EC30006	EMC-BOX CASE ONLY	EMC盒上下蓋	1	38	GC31321	CAM	上離合器頭	1
5	CH90152-1F	SCREW	螺絲	2	39	GP30351	STEEL BALL-4MM	跳脫鋼珠-4mm	2
6	AA30009-1T	CORD 9FT	9呎電源線	1	40	GD21281A	SHAFT-5MM HEX	傳動軸-A頭	1
7	EG30005-4F	PCB	PC板-EMC	1		GD21281B	SHAFT-6.35MM HEX	傳動軸-B頭	1
8	CB21041	HOUSING UNDERSIDE	外殼下蓋	1	41	GP21291A	STEEL BALL FOR LA	起子頭鋼珠 LA	2
9	CA21161	HOUSING UPSIDE	外殼上蓋	1		GP21291B	STEEL BALL FOR LB	起子頭鋼珠 LB	2
10	CJ20011	SUSPENSION RING	起子吊環	1	42	GF21301	WARRING PLATE	扭力推盤	1
11	CC21011	TRIGGER	手按開關桿	1	43	GE21312	WARRING SPRING	扭力彈簧	1
12	CF20061	BREAKER	保護器	1	44	GY21321	WARRING SPRING BASE	止推盤	1
13	E31203-1	BIRDGE DIODE	橋式整流器	1	45	GB21331	CLUTCH CASE	下離合器筒	1
14	E30207	CAPACITOR	電容器	1	46	GO21341	BIT SPRING	起子頭彈簧	1
15	HB50072	START SWITCH	啟動開關半成品	1	47	GJ21351	BIT SLEEVE	起子頭帽	1
16	HA21151	CHANGEOVER SWITCH FOR	正反開關	1	48	GQ21361	"C" RING	起子頭帽C環	1
17	CH20102	SCREW	螺絲	3	49	GL21371	TORQUE ADJ PINS	扭力調整棒	4
18	MO21091	MOTOR ASSEMBLY	馬達整組	1	50	GM21381	TORQUE ADJ RING	扭力調整環	1
19	EB33610-2	CERAMICS CAPACITOR	陶瓷電容	1	51	GS21391	"C" RING	扭力環C環	1
20	MD20151	BRUSH CAP	碳刷蓋	2	52	CD21031	COUPLER	前鎖環	1
21	MC21411	CARBON	碳刷	2	53	MF90061	INSULATING WASHER	墊圈	1
22	ML21421	MOTOR TOP COVER	碳刷座半成品	1	54	P12104	3cm RETAINING CLIP	三公分固定線	1
23	ME21481	ARMATURE BEARING	軸承	2	55	EJ30002-3	CE Box Ass'y	CE盒成品	1
24	MH21471	ARMATURE	電樞	1	56	CH30003	SCREW	螺絲	2
25	MJ90601	MOTOR YORK ASSEMBLY	馬達鐵圈連磁鐵	1	57	CH30671-1	GROUNDING MEANS	接地線	1
26	MB21521A	MOTOR END COVER	馬達前蓋	1	58	GN30442	MAIN BEARING	離合器主軸承	1
27	MA21491B	ASSEMBLY SPRING	馬達固定鐵片	2					

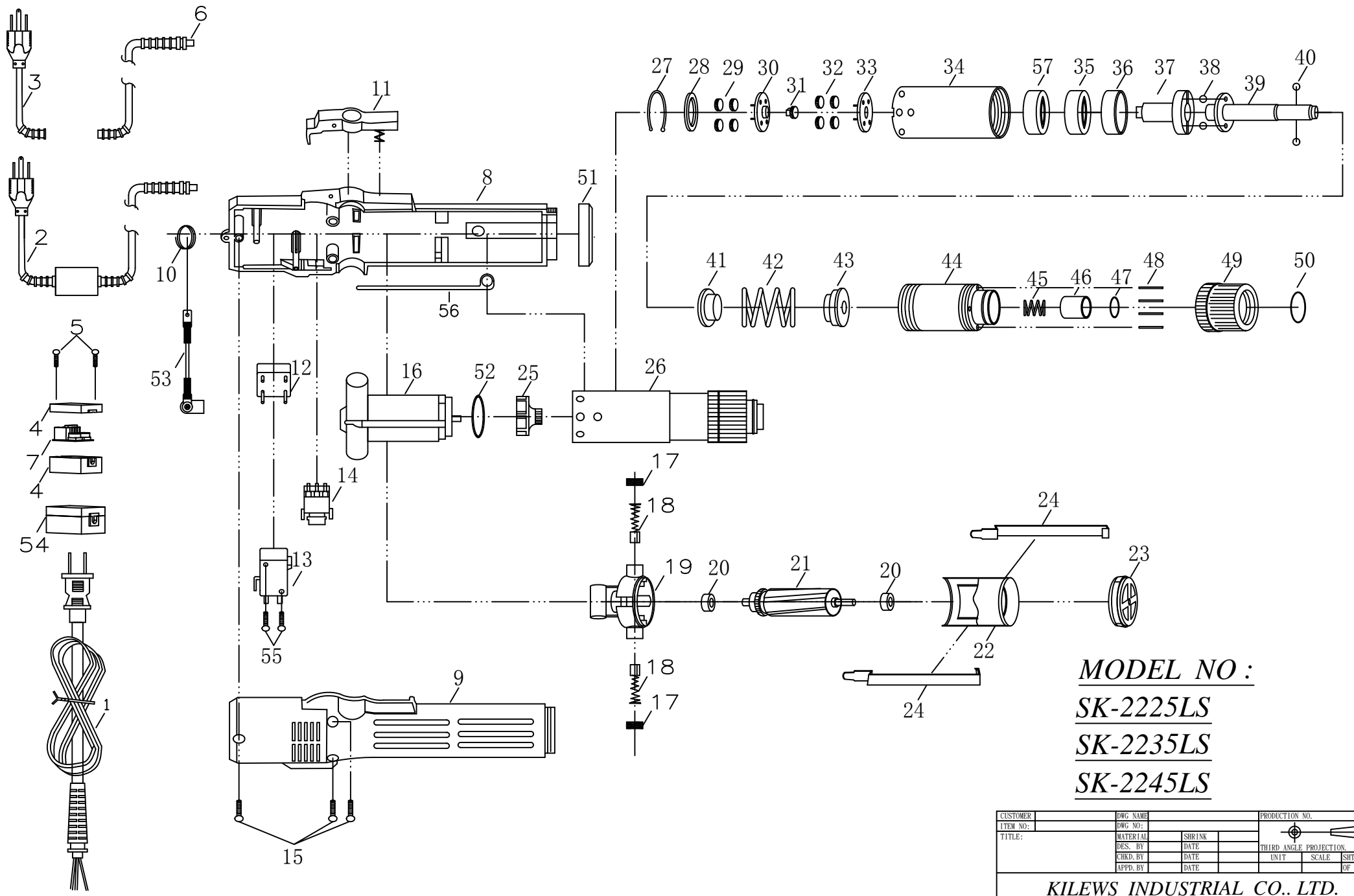

MODEL NO :
SK-2225LS
SK-2235LS
SK-2245LS

CUSTOMER	DWG. NAME	PRODUCTION NO.		
ITEM NO.	DWG. NO.			
TITLE:	MATERIAL	SHRINK	THIRD ANGLE PROJECTION	
	DES. BY	DATE	UNIT	SCALE
	CHKD. BY	DATE		SHT NO.
	APPD. BY	DATE		OF SHTS.
KILEWS INDUSTRIAL CO., LTD.				

No.	PARTS NO.	PARTS NAME-E	PARTS NAME-C	Q'ty	No.	PARTS NO.	PARTS NAME-E	PARTS NAME-C	Q'ty
1	AA20001	CORD	電源線整組 平插	1	28	GI22191	IRON WASHER	齒輪固定片	1
2	AD30001-A	CORD American	電源線整組 美規	1	29	GH20241	GEAR PLANET FOR 2225L	游星齒輪 2225L	3
	AD30001-D	CORD Australia	電源線整組 澳規	1		GH91232	GEAR PLANET FOR 2235L	游星齒輪 2235L	3
	AD30001-F	CORD Europe	電源線整組 歐規	1		GH92231	GEAR PLANET FOR 2245L	游星齒輪 2245L	4
	AA30001-G	CORD UK	電源線整組 英規	1	30	GG22231-2	GEAR SEAT FOR 2225L	上齒盤 2225L	1
	AD30001-J	CORD India	電源線整組 印規	1		GG91242-1	GEAR SEAT FOR 2235L	上齒盤 2235L	1
3	AA30007-1	CORD American 1Ft	電源線美規 1呎	1		GG92241-1	GEAR SEAT FOR 2245L	上齒盤 2245L	1
	AA30007-1D	CORD Australia 1Ft	電源線澳規 1呎	1	31	G20102	GEAR OF CENTER FOR 2225L	中心齒 2225L	1
	AA30007-2	CORD Europe 1Ft	電源線歐規 1呎	1	32	GH20241	GEAR PLANET FOR 2225L	游星齒輪 2225L	3
	AA30007-5	CORD UK 1Ft	電源線英規 1呎	1		GH91232-1	GEAR PLANET FOR 2235L	游星齒輪 2235L	3
	AA30007-5E	CORD India 1Ft	電源線印規 1呎	1		GH92231-1	GEAR PLANET FOR 2245L	游星齒輪 2245L	4
4	EC30006	EMC-BOX CASE ONLY	EMC盒上下蓋	1	33	GG22231-2	GEAR SEAT FOR 2225L	下齒盤 2225L	1
5	CH90152-1F	SCREW	螺絲	2		GG91272-1	GEAR SEAT FOR 2235L	下齒盤 2235L	1
6	AA30009-1T	CORD 9FT	9呎電源線	1		GG92271-1	GEAR SEAT FOR 2245L	下齒盤 2245L	1
7	EG30005-4F	PCB	PC板-EMC	1	34	GA22241	GEAR CASE FOR 2225L	上筒 2225L	1
8	CB22041	HOUSING UNDERSIDE	外殼下蓋	1		GA35241	GEAR CASE FOR 2235L 2245L	上筒 2235L 2245L	1
9	CA22161	HOUSING UPSIDE	外殼上蓋	1	35	GN21251	MAIN BEARING	離合器主軸承	1
10	CJ20011	SUSPENSION RING	起子吊環	1	36	GW22531	IRON RING	鐵墊圈	1
11	CC22011	TRIGGER	手按開關桿	1	37	GC31321	CAM	上離合器頭	1
12	E31203-1	BIRDGE DIODE	橋式整流器	1	38	GP30351	STEEL BALL-4MM	跳脫鋼珠-4mm	2
13	HB50072	START SWITCH	啟動開關半成品	1	39	GD22281A	SHAFT-5MM HEX	傳動軸-A頭	1
14	HA91041	CHANGEOVER SWITCH-2225L	正反開關-2225L	1		GD22281AD	SHAFT FOR "AD" TYPE	傳動軸-AD頭	1
	HA91042	CHANGEOVER SWITCH-2235L	正反開關-2235L	1		GD22281B	SHAFT-6.35MM HEX	傳動軸-B頭	1
	HA92051	CHANGEOVER SWITCH-2245L	正反開關-2245L	1	40	GP22291A	STEEL BALL FOR LA	起子頭鋼珠 LA	2
15	CH20102	SCREW	螺絲	3		GP22291B	STEEL BALL FOR LB	起子頭鋼珠 LB	2
16	MO22092	MOTOR ASSEMBLY	馬達整組	1	41	GF22301	WARRING PLATE	扭力推盤	1
17	MD20151	BRUSH CAP	碳刷蓋	2	42	GE22311	WARRING SPRING FOR 2225L	扭力彈簧 2225L	1
18	MC20161	CARBON	碳刷	2		GE35311	WARRING SPRING FOR 2235L	扭力彈簧 2235L	1
19	ML22421	MOTOR TOP COVER	碳刷座半成品	1		GE92382-3	WARRING SPRING FOR 2245LA&LAD	扭力彈簧 2245LA&LAD	1
20	ME22481-1	ARMATURE BEARING	軸承	2		GE22314	WARRING SPRING FOR 2245LB	扭力彈簧 2245LB	1
21	MH22471	ARMATURE	電樞	1	43	GY22321	WARRING SPRING BASE	止推盤	1
22	MJ90601	MOTOR YORK ASSEMBLY	馬達鐵圈連磁鐵	1	44	GB22331	CLUTCH CASE	下離合器筒	1
23	MB22522A	MOTOR END COVER	馬達前蓋	1	45	GO22341	BIT SPRING	起子頭彈簧	1
24	MA22491B	ASSEMBLY SPRING	馬達固定鐵片	2	46	GJ22351	BIT SLEEVE	起子頭帽	1
25	MK22111	FAN FOR 2225L	風扇連主齒 2225L	1	47	GQ22361	"C" RING	起子頭帽C環	1
	MK91091	FAN FOR 2235L	風扇連主齒 2235L	1	48	GL22371	TORQUE ADJ PINS	扭力調整棒	4
	MK92091	FAN FOR 2245L	風扇連主齒 2245L	1	49	GM22381	TORQUE ADJ RING	扭力調整環	1
26	GZ21121A	CLUTCH ASSY 2225LA	離合器整組 2225LA	1	50	GS22391	"C" RING	扭力環C環	1
	GZ21121AD	CLUTCH ASSY 2225LAD	離合器整組 2225LAD	1	51	CD22031	COUPLER	前鎖環	1
	GZ21121B	CLUTCH ASSY 2225LB	離合器整組 2225LB	1	52	MF90061	INSULATING WASHER	墊圈	1
	GZ35121A	CLUTCH ASSY 2235LA	離合器整組 2235LA	1	53	P12204	3cm RETAINING CLIP	三分公固定線	1
	GZ35121B	CLUTCH ASSY 2235LB	離合器整組 2235LB	1	54	EJ30002-3	CE Box Ass'y	CE盒成品	1
	GZ21145A	CLUTCH ASSY 2245LA	離合器整組 2245LA	1	55	CH30003	SCREW	螺絲	2
	GZ21145AD	CLUTCH ASSY 2245LAD	離合器整組 2245LAD	1	56	CH30671-1	GROUNDING MEANS	接地線	1
	GZ21145B	CLUTCH ASSY 2245LB	離合器整組 2245LB	1	57	GN30442	MAIN BEARING	離合器主軸承	1
27	GK22181	"C" RING	齒輪固定C環	1					

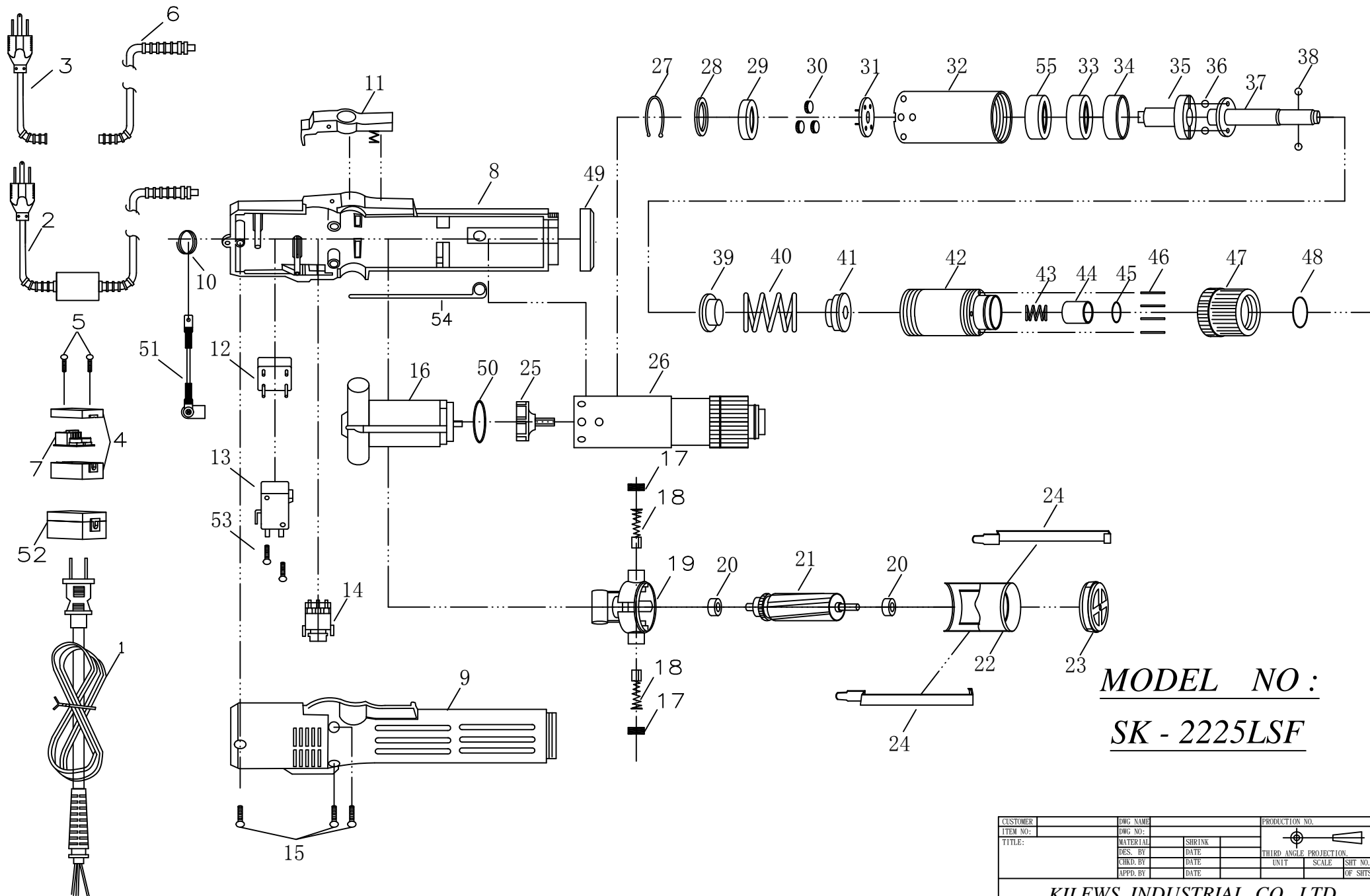

MODEL NO :
SK - 2225LSF

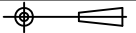
CUSTOMER	DWG NAME		PRODUCTION NO.	
ITEM NO:	DWG NO:			
TITLE:	MATERIAL	SHRINK	THIRD ANGLE PROJECTION	
	DES. BY	DATE	UNIT	SCALE
	CHKD. BY	DATE		SHT NO.
	APPD. BY	DATE		OF SHTS.
KILEWS INDUSTRIAL CO.. LTD.				

No.	PARTS NO.	PARTS NAME-E	PARTS NAME-C	Q'ty	No.	PARTS NO.	PARTS NAME-E	PARTS NAME-C	Q'ty
1	AA20001	CORD	電源線整組 平插	1	26	GZ21121AF	CLUTCH ASSY 2225LFA	離合器整組 2225LFA	1
2	AD30001-A	CORD American	電源線整組 美規	1		GZ21121BF	CLUTCH ASSY 2225LFB	離合器整組 2225LFB	1
	AD30001-D	CORD Australia	電源線整組 澳規	1	27	GK21181	"C" RING	齒輪固定C環	1
	AD30001-F	CORD Europe	電源線整組 歐規	1	28	GI21191	IRON WASHER	齒輪固定片	1
	AA30001-G	CORD UK	電源線整組 英規	1	29	G21301	WASHER,HIGH SPEED	快速齒輪墊圈	1
	AD30001-J	CORD India	電源線整組 印規	1	30	GH21221-1	GEAR PLANET	游星齒輪	3
3	AA30007-1	CORD American 1Ft	電源線美規 1呎	1	31	GG21231-1	GEAR SEAT	下齒盤	1
	AA30007-1D	CORD Australia 1Ft	電源線澳規 1呎	1	32	GA21241	GEAR CASE	上筒	1
	AA30007-2	CORD Europe 1Ft	電源線歐規 1呎	1	33	GN21251	MAIN BEARING	離合器主軸承	1
	AA30007-5	CORD UK 1Ft	電源線英規 1呎	1	34	GW21531	IRON RING	鐵墊圈	1
	AA30007-5E	CORD India 1Ft	電源線印規 1呎	1	35	GC31321	CAM	上離合器頭	1
4	EC30006	EMC-BOX CASE ONLY	EMC盒上下蓋	1	36	GP30351	STEEL BALL-4MM	跳脫鋼珠-4mm	2
5	CH90152-1F	SCREW	螺絲	2	37	GD21281A	SHAFT-5MM HEX	傳動軸-A頭	1
6	AA30009-1T	CORD 9FT	9呎電源線	1		GD21281B	SHAFT-6.35MM HEX	傳動軸-B頭	1
7	EG30005-4F	PCB	PC板-EMC	1	38	GP21291A	STEEL BALL FOR LA	起子頭鋼珠 LA	2
8	CB21041	HOUSING UNDERSIDE	外殼下蓋	1		GP21291B	STEEL BALL FOR LB	起子頭鋼珠 LB	2
9	CA21161	HOUSING UPSIDE	外殼上蓋	1	39	GF21301	WARRING PLATE	扭力推盤	1
10	CJ20011	SUSPENSION RING	起子吊環	1	40	GE21312	WARRING SPRING	扭力彈簧	1
11	CC21011	TRIGGER	手按開關桿	1	41	GY21321	WARRING SPRING BASE	止推盤	1
12	E31203	BIRDGE DIODE	橋式整流器	1	42	GB21331	CLUTCH CASE	下離合器筒	1
13	HB50072	START SWITCH	啟動開關半成品	1	43	GO21341	BIT SPRING	起子頭彈簧	1
14	HA91041	CHANGEOVER SWITCH FOR	正反開關	1	44	GI21351	BIT SLEEVE	起子頭帽	1
15	CH20102	SCREW	螺絲	3	45	GQ21361	"C" RING	起子頭帽C環	1
16	MO22091LF	MOTOR ASSEMBLY	馬達整組	1	46	GL21371	TORQUE ADJ PINS	扭力調整棒	4
17	MD20151	BRUSH CAP	碳刷蓋	2	47	GM21381	TORQUE ADJ RING	扭力調整環	1
18	MC20161	CARBON	碳刷	2	48	GS21391	"C" RING	扭力環C環	1
19	ML22421	MOTOR TOP COVER	碳刷座半成品	1	49	CD21031	COUPLER	前鎖環	1
20	ME21481	ARMATURE BEARING	軸承	2	50	MF90061	INSULATING WASHER	墊圈	1
21	MH22471	ARMATURE	電樞	1	51	P12104	3cm RETAINING CLIP	三公分固定線	1
22	MJ90601	MOTOR YORK ASSEMBLY	馬達鐵圈連磁鐵	1	52	EJ30002-3	CE Box Ass'y	CE盒成品	1
23	MB21521A	MOTOR END COVER	馬達前蓋	1	53	CH30003	SCREW	螺絲	2
24	MA21491B	ASSEMBLY SPRING	馬達固定鐵片	2	54	CH30671-1	GROUNDING MEANS	接地線	1
25	MK21111PF	FAN	風扇連主齒	1	55	GN30442	MAIN BEARING	離合器主軸承	1

Torque Adjustment Operation

To adjust the torque on these screwdrivers. Proceed as follows :

1. Determine the torque output of the tool by checking a tightened Fastener with a torque wrench.
2. Increase or decrease the torque by rotating the Spring Adjusting Ring. Rotating the Ring clockwise to a higher number on the torque Scale increase torque output while rotating the Ring counterclockwise to a lower number decreases the torque output.
3. Check the adjustment with a torque wrench. A number of factors will affect torque output from one job to another. Final torque adjustment should be made at the job through a of series of gradual increase. Always start below the desired torque and work upward.
4. Adjust the bit torque by changing the driving in length of the adjust ring at the end.
5. The relationship between torque scale and bit torque is as shown Ring, in the torque diagram. The figures of torque scale do not indicate bit torque values. However, the clamping torque of screw itself is different form type, size, material of the screw and the material of its mating part. Use it as standard to obtain an appropriate clamping torque.
6. The (Return torque method) in which once-clamped screw is returned with torque wrench or the like is available as one of torque control methods however, note that the measured values by the return torque method generally appear in 10%~30% lower than the actually clamping torque.
7. The torque checker measures the torque of screwdriver. The clamping torque of screw itself is different from the clamped conditions. Understand the correlation between clamping torque values and the torque checker values perform the torque control properly.

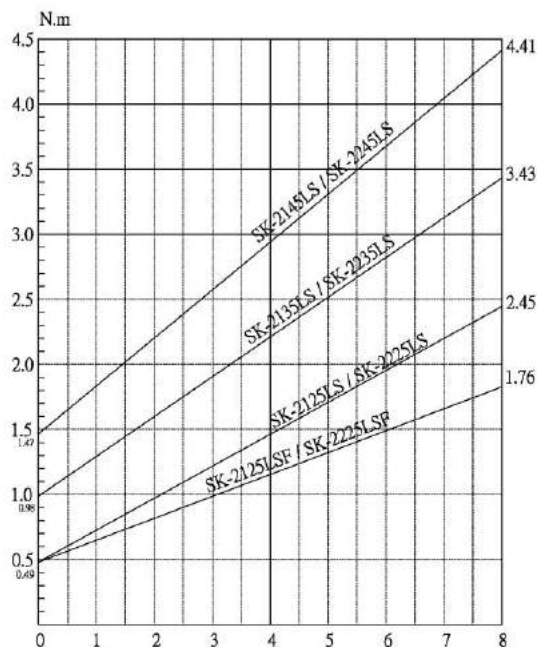

CAUTION

1. Also in reverse rotation, the clutch is turned off in such manner as in normal rotation, stopping the motor running. Accordingly, when the screw tightened at a large torque, set it to a higher torque scale.
2. The number from zero to eight on the Torque Scale are reference number only and not an indication of actual torque output.

RoHS

Equipment name: Electric screwdriver						
Type designation (Type):SK-2125LS , SK-2135LS , SK-2145LS , SK2125LSF						
Unit	Restricted substances and its chemical symbols					
	Lead (Pb)	Mercury (Hg)	Cadmium (Cd)	Hexavalent chromium (Cr ⁺⁶)	Polybrominated biphenyls (PBB)	Polybrominated diphenyl ethers (PBDE)
Housing	○	○	○	○	○	○
Switch line	○	○	○	○	○	○
MOTOR ASSEMBLY	○	○	○	○	○	○
Gear Housing	○	○	○	○	○	○
CORD ASSEMBLY	○	○	○	○	○	○