

S80 series

Ø80mm Xenon Lamp Strobe Signal Lights

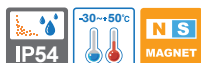

S80S



S80SM



Xenon lamp replacement instructions

Convenient lamp replacement with connector lamp type. Lamp replacement is safe after the product is powered off for 30 mins.



Customization

- AC Type (S80SM)
- Wall mount bracket options (S80S) : Bracket structure allows for threading through the bracket hole or into the wall mount



Wall Mount Bracket
TWS80



Wall Mount Bracket
TWA80



Common Specifications(S80S/ S80SM)

- Ø80mm xenon lamp strobe signal lights
- High efficiency strobe light that offers excellent outdoor visibility and long-distance signal light luminance close to natural light
- Lamp connector fastening structure allows for convenient lamp replacement
- Flashing rate : 60-80 flashes/min
- Materials : Lens-AS, Housing-ABS,
- Ambient operating temperature : -30°C to +50°C
- Protection rating : IP54



S80S Xenon Lamp Strobe Light

- Certificates : CE Compliant

Model number	Voltage	Current	Bulb			Certificates	Weight	Color
			Spec	Standard	Parts no			
S80S	DC12V-24V	Max. 0.435A	220V -350V	BGA2120	47	CE DC only	0.21kg	• R-Red
	AC110V	0.075A		-BBC			0.21kg	• A-Amber
	AC220V	0.060A		I type			0.21kg	• G-Green • B-Blue



Wiring Instructions

- External power line standard : UL1015 AWG18(0.75sq)×2C 400mm
- Product can be wired regardless of polarity



S80SM Xenon Lamp Strobe Light Equipped with Magnet

Model number	Voltage	Current	Bulb			Certificates	Weight	Color
			Spec	Standard	Parts no			
S80SM	DC12V -24V	Max. 0.435A	220V -350V	BGA2120	47	CE DC only	0.24kg	• R-Red
				-BBC			0.24kg	• A-Amber • G-Green • B-Blue



Technical Diagram

(Units : mm)

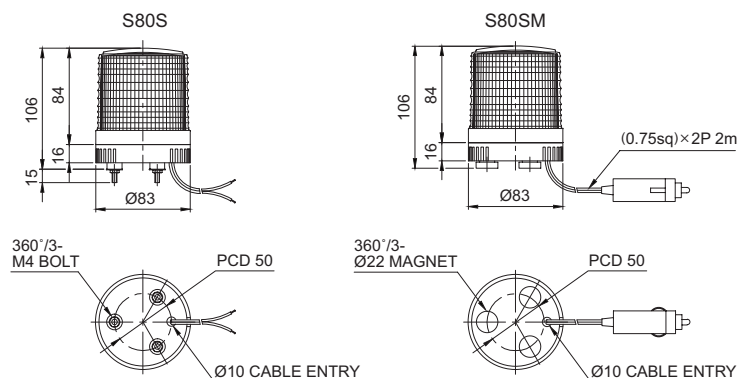

Wiring Instructions

- Cigarette lighter plug : IEC42(0.75sg)×2P 2m



Ordering Specification

S80S	-	24	-	R
[Model number]		[Voltage]		[Color]
• S80S • S80SM		• 12/24-DC12V-24V • 110-AC110V • 220-AC220V		• R-Red • A-Amber • G-Green • B-Blue