

S80 series

Ø80mm Bulb Revolving Warning Lights

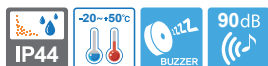

S80R



S80U

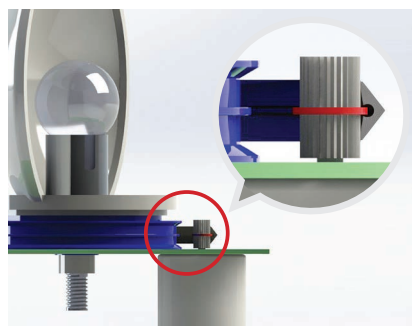

V belt type power transfer system feature

Designed to minimize the abrasion of the belt, and to efficiently deliver torque from the drive shaft to the reflector.

S80R/ S80U Bulb Revolving Warning Lights

- Ø80mm bulb revolving warning lights
- Adopts a special power transmission system that reduces noise and wear
- Built-in buzzer available (Volume : Max 90dB at 1m)
- Revolving speed : 120-140RPM
- Materials : Lens-AS, Housing-ABS, Reflector-Heat resistant ABS
- Ambient operating temperature : -20°C to +50°C
- Protection rating : IP44
- Certificates : CE Compliant

Specifications

Model number	Voltage	Current	Bulb			Certificates	Weight	Color
			Spec	Standard	Parts no			
S80R	DC12V	0.484A	12V5W	T16x35 15S	5	CE DC only	0.28kg	<ul style="list-style-type: none"> • R-Red • A-Amber • G-Green • B-Blue
	DC24V	0.310A	24V5W	T16x35 15S	6		0.28kg	
S80U	AC110V	0.080A	12V5W	T16x35 15S	5		0.48kg	
	AC220V	0.040A	12V5W	T16x35 15S	5		0.48kg	

Technical Diagram

(Units : mm)

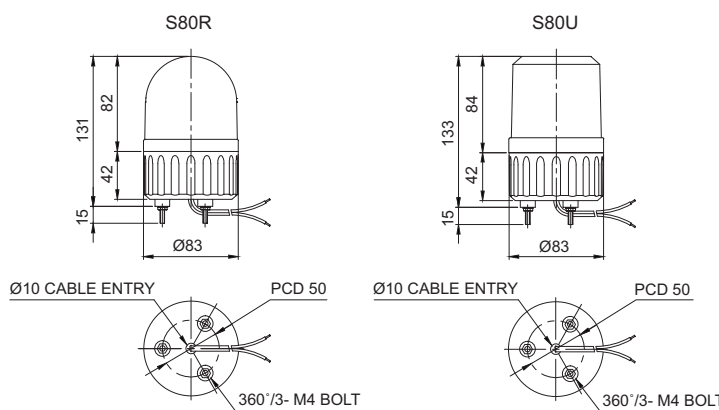

Wiring Instructions

- External power line standard : UL1015 AWG18(0.75sq)×2C 400mm
- DC Type : Black output line is negative(-)

Customization

- Wall mount bracket options :
Bracket structure allows for threading through the bracket hole or into the wall mount



Ordering Specification

S80U	-	BZ	-	220	-	R
[Model number]		[Buzzer option]		[Voltage]		[Color]
<ul style="list-style-type: none"> • S80R • S80U 		<ul style="list-style-type: none"> • None • - No buzzer • BZ • - Built-in buzzer 		<ul style="list-style-type: none"> • 12-DC12V • 24-DC24V • 110-AC110V • 220-AC220V 		<ul style="list-style-type: none"> • R-Red • A-Amber • G-Green • B-Blue