

S180 series

Ø180mm Bulb Revolving Warning Lights

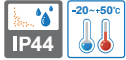

S180R



S180R-FT



S180 type has strong flashing light characteristics with dual reflector.

S180R/ S180R-FT Bulb Revolving Warning Lights

- Features high durability with housing made of corrosion-proof stainless steel
- Excellent long distance signal transmission effect with 35W capacity bulb and dual reflectors
- FT Models : Easy installation with flange brackets
- Materials : Lens-AS, Housing-STS, Reflector-PC
- Ambient operating temperature : -20°C to +50°C
- Protection rating : IP44

Specifications

Model number	Voltage	Current	Bulb			Certificates	Weight	Color
			Spec	Standard	Parts no			
S180R	DC12V	3.077A	12V35W	RP35 15S	29	-	1.22kg	• R-Red
	DC24V	1.544A	24V35W	RP35 15S	30		1.22kg	• A-Amber
S180R-FT	AC110V	0.388A	12V35W	RP35 15S	29		1.99kg	• G-Green
	AC220V	0.194A	12V35W	RP35 15S	29		1.99kg	• B-Blue

Technical Diagram

(Units : mm)

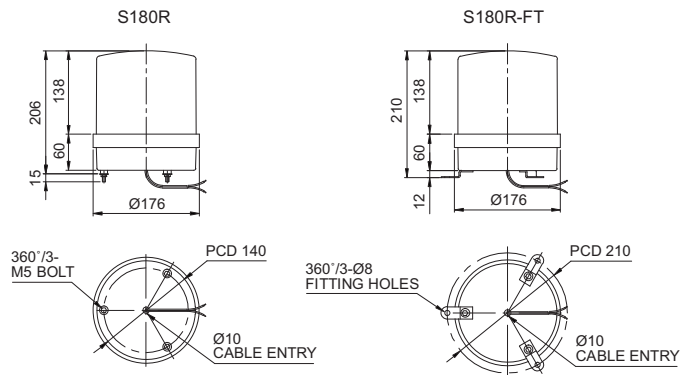

Wiring Instructions

- External power line standard : UL1015 AWG18(0.75sq)×2C 400mm
- DC type : Black output line is negative(-)

Ordering Specification

S180R-FT	-	24	-	R
[Model number]		[Voltage]		[Color]
<ul style="list-style-type: none"> • S180R • S180R-FT 		<ul style="list-style-type: none"> • 12-DC12V • 24-DC24V • 110-AC110V • 220-AC220V 		<ul style="list-style-type: none"> • R-Red • A-Amber • G-Green • B-Blue