

# S125 series

## Ø125mm Bulb Revolving Warning Lights

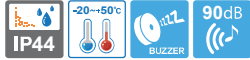

S125U



CNC machine equipped with S125U

### S125U Bulb Revolving Warning Light

• Protection rating : IP44

Model number	Voltage	Current	Bulb			Certificates	Weight	Color
			Spec	Standard	Parts no			
S125U	DC12V	0.966A	12V10W	T16x35 15S	9	 DC only	0.41kg	<ul style="list-style-type: none"> <li>● R-Red</li> <li>● A-Amber</li> <li>● G-Green</li> <li>● B-Blue</li> </ul>
	DC24V	0.566A	24V10W	T16x35 15S	10		0.41kg	
	AC110V	0.130A	12V10W	T16x35 15S	9		0.65kg	
	AC220V	0.065A	12V10W	T16x35 15S	9		0.65kg	

### Technical Diagram

(Units : mm)

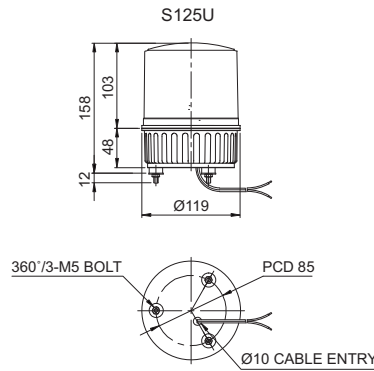

### Wiring Instructions

- External power line standard : UL1015 AWG18(0.75sq)×2C 400mm
- DC Type : Black output line is negative(-)

### Customization

- 2 buzzer sound types : Both prolonged (beep, beep) and staccato(beep, beep, beep) buzzer output available
- Wall mount bracket options :  
Bracket structure allows for threading through the bracket hole or into the wall mount



Wall Mount Bracket  
SWP125



Wall Mount Bracket  
SWM125

### Ordering Specification

S125U	-	BZ	-	220	-	R
[Model number]		[Buzzer option]		[Voltage]		[Color]
• S125U		<ul style="list-style-type: none"> <li>• None</li> <li>- No buzzer</li> <li>• BZ</li> <li>- Built-in buzzer</li> </ul>		<ul style="list-style-type: none"> <li>• 12-DC12V</li> <li>• 24-DC24V</li> <li>• 110-AC110V</li> <li>• 220-AC220V</li> </ul>		<ul style="list-style-type: none"> <li>● R-Red</li> <li>● A-Amber</li> <li>● G-Green</li> <li>● B-Blue</li> </ul>

