

Rectangular Inductive Proximity Sensors



PSN Series (DC 2-wire)

For your safety, read and follow the considerations written in the instruction manual, other manuals and Autonics website.

The specifications, dimensions, etc. are subject to change without notice for product improvement. Some models may be discontinued without notice.

Features

- Excellent noise immunity with specialized sensor IC
- Built-in surge protection circuit, output short over current protection circuit, reverse polarity protection
- Simple operation, reliable performance, and high durability
- Operation indicator (red LED)
- IP67 protection structure (IEC standard)

Safety Considerations

- Observe all 'Safety Considerations' for safe and proper operation to avoid hazards.
- ⚠ symbol indicates caution due to special circumstances in which hazards may occur.

⚠ Warning Failure to follow instructions may result in serious injury or death.

- 01. Fail-safe device must be installed when using the unit with machinery that may cause serious injury or substantial economic loss. (e.g. nuclear power control, medical equipment, ships, vehicles, railways, aircraft, combustion apparatus, safety equipment, crime/disaster prevention devices, etc.)**
Failure to follow this instruction may result in personal injury, economic loss or fire.
- 02. Do not use the unit in the place where flammable/explosive/corrosive gas, high humidity, direct sunlight, radiant heat, vibration, impact, or salinity may be present.**
Failure to follow this instruction may result in explosion or fire.
- 03. Do not disassemble or modify the unit.**
Failure to follow this instruction may result in fire.
- 04. Do not connect, repair, or inspect the unit while connected to a power source.**
Failure to follow this instruction may result in fire.
- 05. Check 'Connections' before wiring.**
Failure to follow this instruction may result in fire.

⚠ Caution Failure to follow instructions may result in injury or product damage.

- 01. Use the unit within the rated specifications.**
Failure to follow this instruction may result in fire or product damage.
- 02. Use a dry cloth to clean the unit, and do not use water or organic solvent.**
Failure to follow this instruction may result in fire.
- 03. Do not supply power without load.**
Failure to follow this instruction may result in fire or product damage.

Cautions during Use

- Follow instructions in 'Cautions during Use'. Otherwise, it may cause unexpected accidents.
- 12-24 VDC \equiv power supply should be insulated and limited voltage/current or Class 2, SELV power supply device.
- Use the product, after 0.8 sec of supplying power.
- Wire as short as possible and keep away from high voltage lines or power lines, to prevent surge and inductive noise. Do not use near the equipment which generates strong magnetic force or high frequency noise (transceiver, etc.).
In case installing the product near the equipment which generates strong surge (motor, welding machine, etc.), use diode or varistor to remove surge.
- This unit may be used in the following environments.
 - Indoors (in the environment condition rated in 'Specifications')
 - Altitude max. 2,000 m
 - Pollution degree 2
 - Installation category II

Cautions for Installation

- Install the unit correctly with the usage environment, location, and the designated specifications.
- Do NOT impacts with a hard object or excessive bending of the wire lead-out. It may cause damage the water resistance.
- Do NOT pull the \varnothing 2.5 mm cable with a tensile strength of 20 N, the \varnothing 4 mm cable with a tensile strength of 30 N or over and the \varnothing 5 mm cable with a tensile strength of 50 N or over. It may result in fire due to the broken wire.
- When extending wire, use AWG 22 cable or over within 200 m.
- Tighten the installing screw with under 0.49 N m tightening torque when mounting the bracket.

Ordering Information

This is only for reference.

For selecting the specific model, follow the Autonics web site.

PSNT 17 - 5 D ① ②

① Control output

O: Normally Open

C: Normally Closed

② Sensing side

No-mark: Standard type

U: Upper side type

Product Components

- Bracket × 1
- M3 Blot × 2

Connections

- LOAD can be wired to any direction.
- Connect LOAD before supplying the power.

■ Cable type

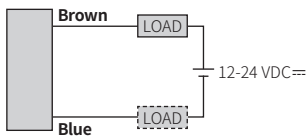

■ Inner circuit

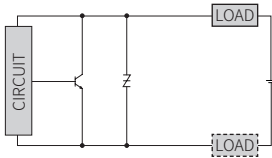

Operation Timing Chart

	Normally open	Normally closed
Sensing target	Presence Nothing	Presence Nothing
Load	Operation Return	Operation Return
Operation indicator (red)	ON OFF	ON OFF

Specifications

Installation	Standard type / Upper side type
Model	PSNT17-5D□□
Sensing side length	18 mm
Sensing distance	5 mm
Setting distance	0 to 3.5 mm
Hysteresis	≤ 10 % of sensing distance
Standard sensing target: iron	18 × 18 × 1 mm
Response frequency ⁰¹⁾	700 Hz
Affection by temperature	± 10 % for sensing distance at ambient temperature 20 °C
Indicator	Operation indicator (red)
Approval	CE [EUC]
Unit weight ()	≈ 58 g (≈ 79 g)

01) The response frequency is the average value. The standard sensing target is used and the width is set as 2 times of the standard sensing target, 1/2 of the sensing distance for the distance.

Power supply	12-24 VDC \equiv (ripple P-P: ≤ 10 %), operating voltage: 10-30 VDC \equiv
Leakage current	≤ 0.6 mA
Control output	2 to 100 mA
Residual voltage	≤ 3.5 V
Protection circuit	Surge protection circuit, output short over current protection circuit, reverse polarity protection
Insulation type	≥ 50 M Ω (500 VDC \equiv megger)
Dielectric strength	1,500 VAC \sim 50/60 Hz for 1 min (between all terminals and case)
Vibration	1 mm amplitude at frequency 10 to 55 Hz (for 1 min) in each X, Y, Z direction for 2 hours
Shock	500 m/s ² (≈ 50 G) in each X, Y, Z direction for 3 times
Ambient temperature	-25 to 70 °C, storage: -30 to 80 °C (non-freezing or non-condensation)
Ambient humidity	35 to 95 %RH, storage: 35 to 95 %RH (non-freezing or non-condensation)
Protection structure	IP67 (IEC standards)
Connection	Cable type model
Wire spec.	Ø 4 mm, 2-wire, 2 m
Connector spec.	AWG 22 (0.08 mm, 60-wire), insulator diameter: Ø 1.25 mm
Material	Case: PBT, standard type cable (black): polyvinyl chloride (PVC)

Dimensions

• Unit: mm, For the detailed dimensions of the product, follow the Autonics web site.

A	Operation indicator (red)	B	Tap hole
----------	---------------------------	----------	----------

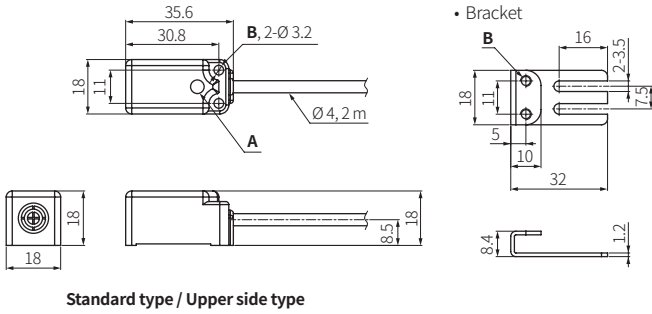

Setting Distance Formula

Detecting distance can be changed by the shape, size or material of the target.

For stable sensing, install the unit within the 70% of sensing distance.

Setting distance (Sa)
= Sensing distance (Sn) × 70%

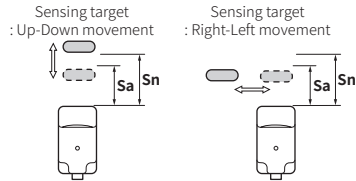

Mutual-interference & Influence by Surrounding Metals

■ Mutual-interference

When plural proximity sensors are mounted in a close row, malfunction of sensor may be caused due to mutual interference.

Therefore, be sure to provide a minimum distance between the two sensors, as below table.

A	30 mm	B	36 mm
----------	-------	----------	-------

[Face to Face]

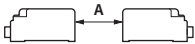

[Parallel]

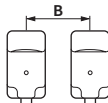

■ Influence by surrounding metals

When sensors are mounted on metallic panel, it must be prevented sensors from being affected by any metallic object except target. Therefore, be sure to provide a minimum distance as below chart.

c	4 mm	d	15 mm	m	18 mm
----------	------	----------	-------	----------	-------

• Standard type

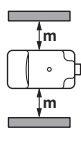
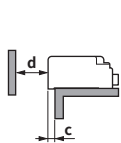

• Upper side type

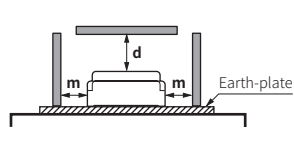

Sensing Distance Feature Data by Target Material and Size

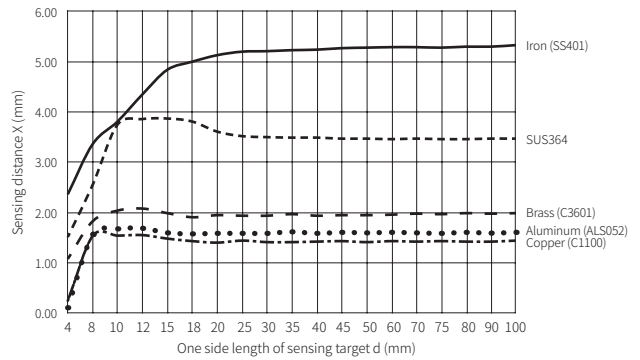
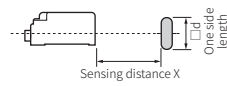

Sensing Distance Feature Data by Parallel (Left/Right) Movement

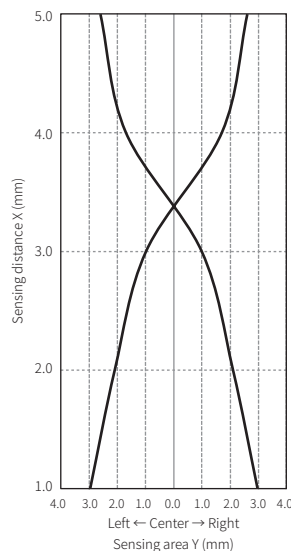
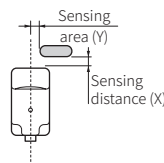

Rectangular Inductive Proximity Sensors



PSN Series (DC 3-wire) PRODUCT MANUAL

For your safety, read and follow the considerations written in the instruction manual, other manuals and Autonics website.

The specifications, dimensions, etc. are subject to change without notice for product improvement. Some models may be discontinued without notice.

Major Features

- Excellent noise immunity with specialized sensor IC
- Built-in surge protection circuit, output short over current protection circuit, reverse polarity protection
- Simple operation, reliable performance, and high durability
- Alternate frequency models allow adjacent installation of multiple sensors without interference (PSN17-□-F model)
- Operation indicator (red LED)
- IP67 protection structure (IEC standard)

Safety Considerations

- Observe all 'Safety Considerations' for safe and proper operation to avoid hazards.
- ⚠ symbol indicates caution due to special circumstances in which hazards may occur.

⚠ Warning Failure to follow instructions may result in serious injury or death.

- 01. Fail-safe device must be installed when using the unit with machinery that may cause serious injury or substantial economic loss. (e.g. nuclear power control, medical equipment, ships, vehicles, railways, aircraft, combustion apparatus, safety equipment, crime/disaster prevention devices, etc.)**
Failure to follow this instruction may result in personal injury, economic loss or fire.
- 02. Do not use the unit in the place where flammable/explosive/corrosive gas, high humidity, direct sunlight, radiant heat, vibration, impact, or salinity may be present.**
Failure to follow this instruction may result in explosion or fire.
- 03. Do not disassemble or modify the unit.**
Failure to follow this instruction may result in fire.
- 04. Do not connect, repair, or inspect the unit while connected to a power source.**
Failure to follow this instruction may result in fire.
- 05. Check 'Connections' before wiring.**
Failure to follow this instruction may result in fire.

⚠ Caution Failure to follow instructions may result in injury or product damage.

- 01. Use the unit within the rated specifications.**
Failure to follow this instruction may result in fire or product damage.
- 02. Use a dry cloth to clean the unit, and do not use water or organic solvent.**
Failure to follow this instruction may result in fire.

Cautions during Use

- Follow instructions in 'Cautions during Use'. Otherwise, it may cause unexpected accidents.
- 12-24 VDC= power supply should be insulated and limited voltage/current or Class 2, SELV power supply device.
- Use the product, after 0.8 sec of supplying power.
- Wire as short as possible and keep away from high voltage lines or power lines, to prevent surge and inductive noise. Do not use near the equipment which generates strong magnetic force or high frequency noise (transceiver, etc.). In case installing the product near the equipment which generates strong surge (motor, welding machine, etc.), use diode or varistor to remove surge.
- This unit may be used in the following environments.
 - Indoors (in the environment condition rated in 'Specifications')
 - Altitude max. 2,000 m
 - Pollution degree 2
 - Installation category II

Cautions for Installation

- Install the unit correctly with the usage environment, location, and the designated specifications.
- Do NOT impacts with a hard object or excessive bending of the wire lead-out. It may cause damage the water resistance.
- Do NOT pull the Ø 2.5 mm cable with a tensile strength of 20 N, the Ø 4 mm cable with a tensile strength of 30 N or over and the Ø 5 mm cable with a tensile strength of 50 N or over. It may result in fire due to the broken wire.
- When extending wire, use AWG 22 cable or over within 200 m.
- Refer to the table below for the screw tightening torque when mounting the bracket.

	PSN17	PSN25	PSN30	PSN40
Tightening torque	0.49 N m	0.98 N m	0.98 N m	0.98 N m

Ordering Information

This is only for reference.

For selecting the specific model, follow the Autonics web site.

PSN ① - ② **D** ③ ④ - ⑤

① Sensing side length

Number: Side length of head (unit: mm)

④ Sensing side

No-mark: Standard type
U: Upper side type

② Sensing distance

Number: Sensing distance (unit: mm)

⑤ Frequency

No-mark: Standard type
F: Differential frequency type

③ Control output

N: NPN Normally Open
N2: NPN Normally Closed
P: PNP Normally Open
P2: PNP Normally Closed

Product Components

	PSN17	PSN25	PSN30	PSN40
Bracket	1 ×	1 ×	1 ×	1 ×
Bolt	M3 × 2	M4 × 2	M4 × 2	M5 × 2

Connections

■ Cable type

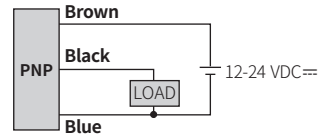
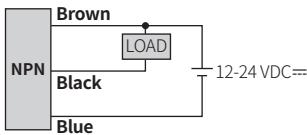

■ Inner circuit (NPN output)

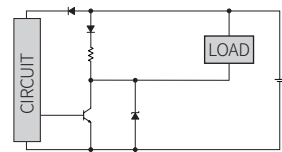

■ Inner circuit (PNP output)

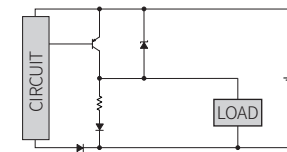

Operation Timing Chart

		Normally open	Normally closed
Sensing target	Presence		
	Nothing		
Load	Operation		
	Return		
Output voltage	NPN output		
	PNP output		
Operation indicator (red)			

Specifications

Installation	Standard type / Upper side type		Standard type			
	PSN17-5D□□-□	PSN17-8D□□-□	PSN25-5D□	PSN30-10D□	PSN30-15D□	PSN40-20D□
Model	18 mm	18 mm	25 mm	30 mm	30 mm	40 mm
Sensing side length	5 mm	8 mm	5 mm	10 mm	15 mm	20 mm
Sensing distance	0 to 3.5 mm	0 to 5 mm	0 to 3.5 mm	0 to 7 mm	0 to 10.5 mm	0 to 14 mm
Setting distance	≤ 10 % of sensing distance					
Hysteresis	18 × 18 × 1 mm	25 × 25 × 1 mm	25 × 25 × 1 mm	30 × 30 × 1 mm	45 × 45 × 1 mm	60 × 60 × 1 mm
Standard sensing target: iron	700 Hz	200 Hz	300 Hz	250 Hz	200 Hz	100 Hz
Response frequency (0.1)	± 10 % for sensing distance at ambient temperature 20 °C					
Affection by temperature	Operation indicator (red)					
Indicator	CE EAC	CE EAC	CE EAC	CE EAC	CE EAC	CE EAC
Approval	≈ 62 g (≈ 83 g)	≈ 62 g (≈ 83 g)	≈ 71 g (≈ 103 g)	≈ 96 g (≈ 165 g)	≈ 96 g (≈ 165 g)	≈ 135 g (≈ 225 g)
Unit weight (package)	12-24 VDC≡ (ripple P-P: ≤ 10 %), operating voltage: 10-30 VDC≡					
Power supply	≤ 10 mA					
Current consumption	≤ 200 mA					
Control output	≤ 1.5 V					
Residual voltage	Surge protection circuit, output short over current protection circuit, reverse polarity protection					
Protection circuit	≥ 50 MΩ (500 VDC≡ megger)					
Insulation type	1,500 VAC ~ 50/60 Hz for 1 min (between all terminals and case)					
Dielectric strength	1 mm amplitude at frequency 10 to 55 Hz (for 1 min) in each X, Y, Z direction for 2 hours					
Vibration	500 m/s ² (≈ 50 G) in each X, Y, Z direction for 3 times					
Shock	-25 to 70 °C, storage: -30 to 80 °C (non-freezing or non-condensation)					
Ambient temp.	35 to 95 %RH, storage: 35 to 95 %RH (non-freezing or non-condensation)					
Ambient humi.	IP67 (IEC standards)					
Protection structure	Cable type model					
Connection	Ø 4 mm, 3-wire, 2 m					
Wire spec.	AWG 22 (0.08 mm, 60-wire), insulator diameter: Ø 1.25 mm					
Connector spec.	Case: Heat-resistant ABS, standard type cable (black): polyvinyl chloride (PVC)					
Material	01) The response frequency is the average value. The standard sensing target is used and the width is set as 2 times of the standard sensing target, 1/2 of the sensing distance for the distance.					

01) The response frequency is the average value. The standard sensing target is used and the width is set as 2 times of the standard sensing target, 1/2 of the sensing distance for the distance.

Power supply	12-24 VDC≡ (ripple P-P: ≤ 10 %), operating voltage: 10-30 VDC≡
Current consumption	≤ 10 mA
Control output	≤ 200 mA
Residual voltage	≤ 1.5 V
Protection circuit	Surge protection circuit, output short over current protection circuit, reverse polarity protection
Insulation type	≥ 50 MΩ (500 VDC≡ megger)
Dielectric strength	1,500 VAC ~ 50/60 Hz for 1 min (between all terminals and case)
Vibration	1 mm amplitude at frequency 10 to 55 Hz (for 1 min) in each X, Y, Z direction for 2 hours
Shock	500 m/s ² (≈ 50 G) in each X, Y, Z direction for 3 times
Ambient temp.	-25 to 70 °C, storage: -30 to 80 °C (non-freezing or non-condensation)
Ambient humi.	35 to 95 %RH, storage: 35 to 95 %RH (non-freezing or non-condensation)
Protection structure	IP67 (IEC standards)
Connection	Cable type model
Wire spec.	Ø 4 mm, 3-wire, 2 m
Connector spec.	AWG 22 (0.08 mm, 60-wire), insulator diameter: Ø 1.25 mm
Material	Case: Heat-resistant ABS, standard type cable (black): polyvinyl chloride (PVC)

Dimensions

• Unit: mm, For the detailed dimensions of the product, follow the Autonics web site.

A	Operation indicator (red)	B	Tap hole
---	---------------------------	---	----------

■ PSN17

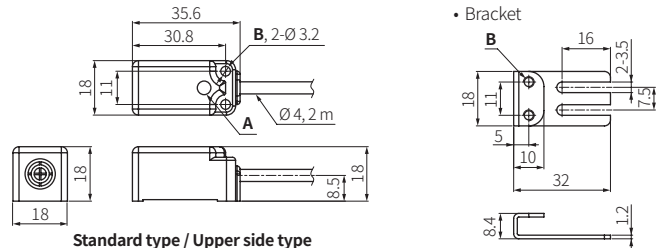

Standard type / Upper side type

■ PSN25

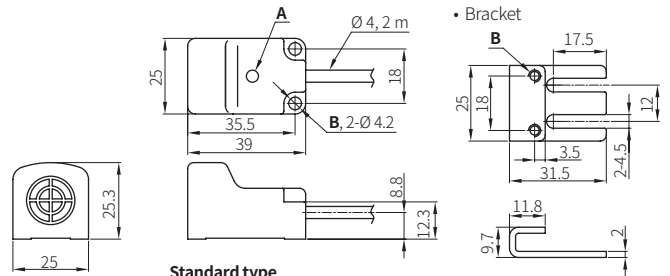

Standard type

■ PSN30

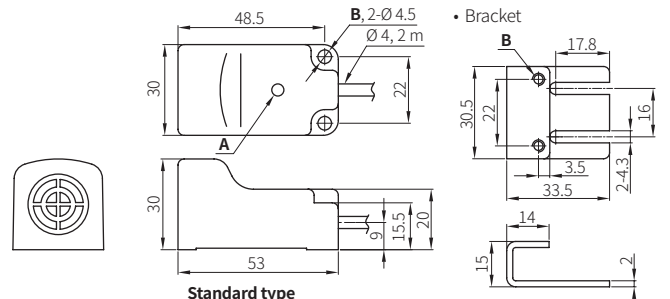

Standard type

■ PSN40

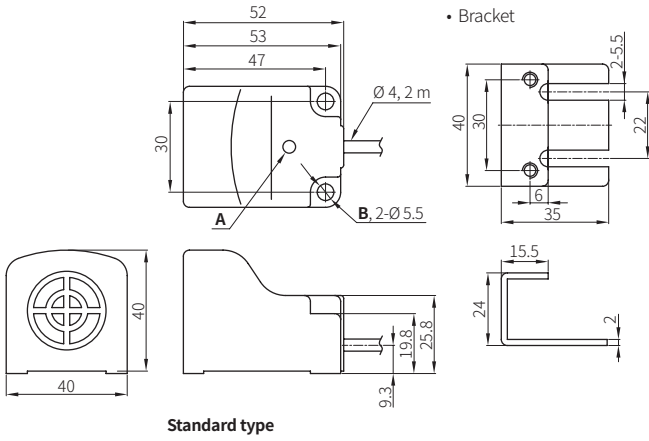

Standard type

Setting Distance Formula

Detecting distance can be changed by the shape, size or material of the target.

For stable sensing, install the unit within the 70% of sensing distance.

Setting distance (Sa)
= Sensing distance (Sn) × 70%

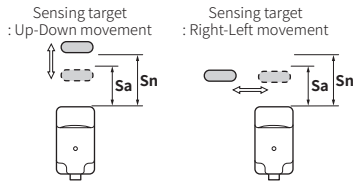

Mutual-interference & Influence by Surrounding Metals

■ Mutual-interference

When plural proximity sensors are mounted in a close row, malfunction of sensor may be caused due to mutual interference.

Therefore, be sure to provide a minimum distance between the two sensors, as below table.

[Face to Face]

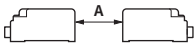

[Parallel]

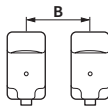

■ Differential frequency

When the several proximity sensors are installed closely each other, install standard type and differential frequency type sensors alternatively to prevent mutual interference due to frequency interference.

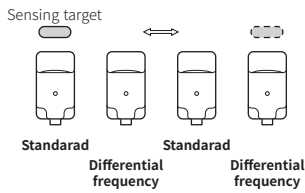

■ Influence by surrounding metals

When sensors are mounted on metallic panel, it must be prevented sensors from being affected by any metallic object except target. Therefore, be sure to provide a minimum distance as below chart.

• Standard type

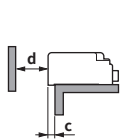

• Upper side type

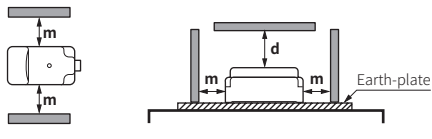

(unit: mm)

Model	PSN17-5	PSN17-8	PSN25	PSN30-10	PSN30-15	PSN40
A	30	48	30	60	90	120
B	36	40	40	50	65	70
c	4	4	4	5	5	5
d	15	24	15	30	45	60
m	18	20	20	25	35	35

Sensing Distance Feature Data by Target Material and Size

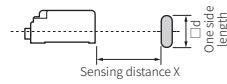

• PSN17-5

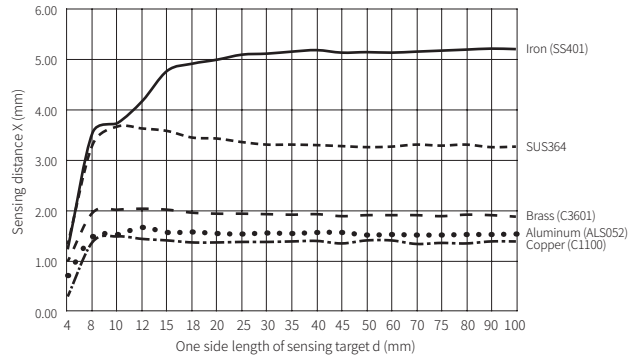

• PSN17-8

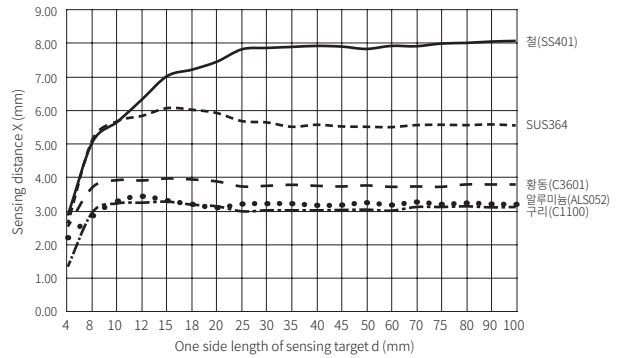

• PSN25

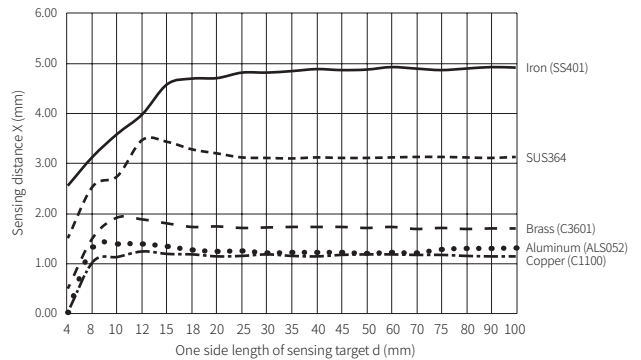

• PSN30-10

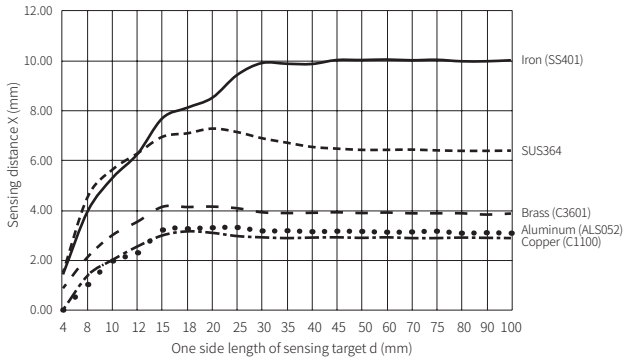

• PSN30-15

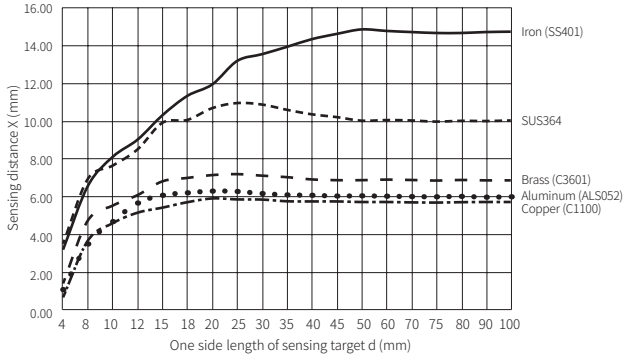

• PSN40

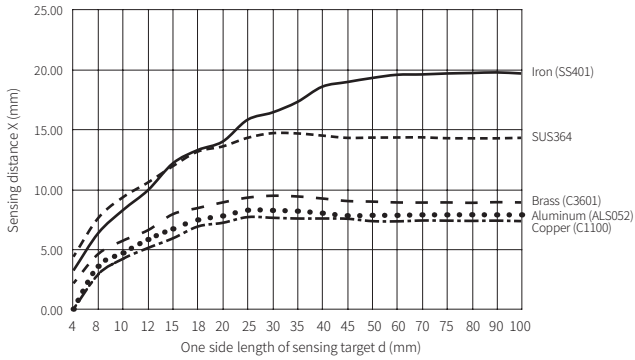

Sensing Distance Feature Data by Parallel (Left/Right) Movement

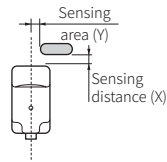

• PSN17

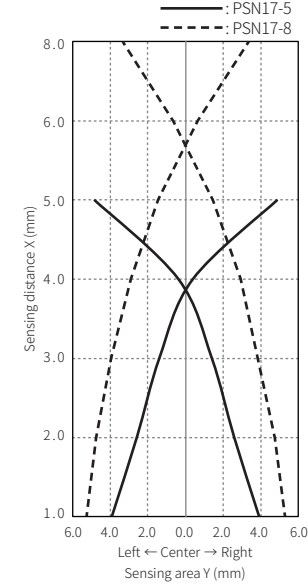

• PSN25

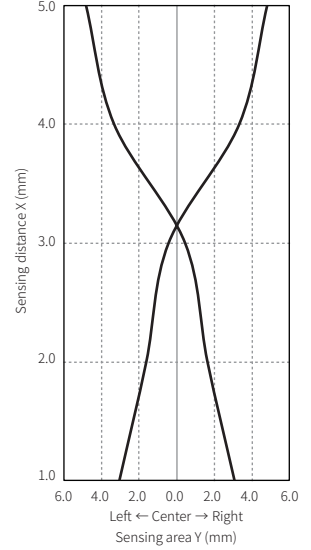

• PSN30

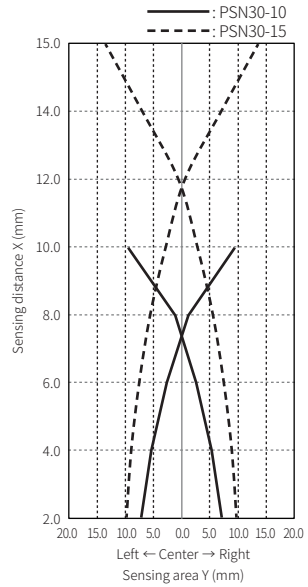

• PSN40

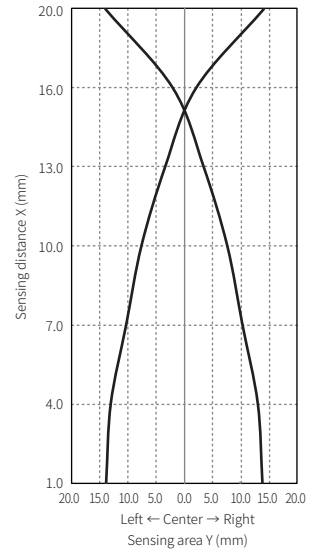

Rectangular Inductive Proximity Sensors



PSN Series (AC 2-wire)

PRODUCT MANUAL

For your safety, read and follow the considerations written in the instruction manual, other manuals and Autonics website.

The specifications, dimensions, etc. are subject to change without notice for product improvement. Some models may be discontinued without notice.

Features

- Excellent noise immunity with specialized sensor IC
- Built-in surge protection circuit
- Simple operation, reliable performance, and high durability
- Operation indicator (red LED)
- IP67 protection structure (IEC standard)

Safety Considerations

- Observe all 'Safety Considerations' for safe and proper operation to avoid hazards.
- ⚠ symbol indicates caution due to special circumstances in which hazards may occur.

⚠ Warning Failure to follow instructions may result in serious injury or death.

- 01. Fail-safe device must be installed when using the unit with machinery that may cause serious injury or substantial economic loss. (e.g. nuclear power control, medical equipment, ships, vehicles, railways, aircraft, combustion apparatus, safety equipment, crime/disaster prevention devices, etc.)**
Failure to follow this instruction may result in personal injury, economic loss or fire.
- 02. Do not use the unit in the place where flammable/explosive/corrosive gas, high humidity, direct sunlight, radiant heat, vibration, impact, or salinity may be present.**
Failure to follow this instruction may result in explosion or fire.
- 03. Do not disassemble or modify the unit.**
Failure to follow this instruction may result in fire or electric shock.
- 04. Do not connect, repair, or inspect the unit while connected to a power source.**
Failure to follow this instruction may result in fire or electric shock.
- 05. Check 'Connections' before wiring.**
Failure to follow this instruction may result in fire or electric shock.

⚠ Caution Failure to follow instructions may result in injury or product damage.

- 01. Use the unit within the rated specifications.**
Failure to follow this instruction may result in fire or product damage.
- 02. Use a dry cloth to clean the unit, and do not use water or organic solvent.**
Failure to follow this instruction may result in fire or electric shock.
- 03. Do not supply power without load.**
Failure to follow this instruction may result in fire or product damage.

Cautions during Use

- Follow instructions in 'Cautions during Use'. Otherwise, it may cause unexpected accidents.
- Wire as short as possible and keep away from high voltage lines or power lines, to prevent surge and inductive noise. Do not use near the equipment which generates strong magnetic force or high frequency noise (transceiver, etc.). In case installing the product near the equipment which generates strong surge (motor, welding machine, etc.), use diode or varistor to remove surge.
- Do not connect capacity load to the output terminal directly.
- This unit may be used in the following environments.
 - Indoors (in the environment condition rated in 'Specifications')
 - Altitude max. 2,000 m
 - Pollution degree 2
 - Installation category II

Cautions for Installation

- Install the unit correctly with the usage environment, location, and the designated specifications.
- Do NOT impacts with a hard object or excessive bending of the wire lead-out. It may cause damage the water resistance.
- Do NOT pull the $\varnothing 2.5$ mm cable with a tensile strength of 20 N, the $\varnothing 4$ mm cable with a tensile strength of 30 N or over and the $\varnothing 5$ mm cable with a tensile strength of 50 N or over. It may result in fire due to the broken wire.
- When extending wire, use AWG 22 cable or over within 200 m.
- Tighten the installing screw with under 0.59 N m tightening torque when mounting the bracket.

Ordering Information

This is only for reference, the actual product does not support all combinations. For selecting the specified model, follow the Autonics website.

PSN ① - ② **A** ③

① Sensing side length

Number: Side length of head (unit: mm)

③ Control output

O: Normally Open
C: Normally Closed

② Sensing distance

Number: Sensing distance (unit: mm)

Product Components

	PSN25	PSN30	PSN40
Bracket	1 ×	1 ×	1 ×
Bolt	M4 × 2	M4 × 2	M5 × 2

Connection

- LOAD can be wired to any direction.
- Connect LOAD before supplying the power.

■ Cable type

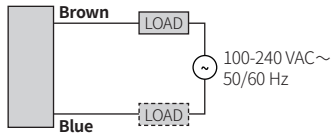

■ Inner circuit

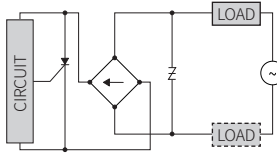

Operation Timing Chart

	Normally open	Normally closed
Sensing target	Presence Nothing	Presence Nothing
Load	Operation Return	Operation Return
Operation indicator (red)	ON OFF	ON OFF

Specifications

Installation	Standard type			
Model	PSN25-5A□	PSN30-10A□	PSN30-15A□	PSN40-20A□
Sensing side length	25 mm	30 mm	30 mm	40 mm
Sensing distance	5 mm	10 mm	15 mm	20 mm
Setting distance	0 to 3.5 mm	0 to 7 mm	0 to 10.5 mm	0 to 14 mm
Hysteresis	≤ 10% of sensing distance			
Standard sensing target: iron	25 × 25 × 1 mm	30 × 30 × 1 mm	45 × 45 × 1 mm	60 × 60 × 1 mm
Response frequency ⁰¹⁾	20 Hz			
Affection by temperature	± 10% for sensing distance at ambient temperature 20 °C			
Indicator	Operation indicator (red)			
Approval	CE EAC	CE EAC	CE EAC	CE EAC
Unit weight (package)	≈ 66 g (≈ 98 g)	≈ 92 g (≈ 161 g)	≈ 92 g (≈ 161 g)	≈ 130 g (≈ 219 g)

01) The response frequency is the average value. The standard sensing target is used and the width is set as 2 times of the standard sensing target, 1/2 of the sensing distance for the distance.

Power supply	100 - 240 VAC~ 50 / 60 Hz, operating voltage: 85 - 264 VAC~
Leakage current	≤ 2.5 mA
Control output	5 to 200 mA
Residual voltage	≤ 10 V
Protection circuit	Surge protection circuit
Insulation type	≥ 50 MΩ (500 VDC≐ megger)
Dielectric strength	Between all terminals and case: 1,500 VAC~ 50/60 Hz for 1 min
Vibration	1 mm double amplitude at frequency 10 to 55 Hz (for 1 min) in each X, Y, Z direction for 2 hours
Shock	500 m/s ² (≈ 50 G) in each X, Y, Z direction for 3 times
Ambient temperature	-25 to 70 °C, storage: -30 to 80 °C (no freezing or condensation)
Ambient humidity	35 to 95 %RH, storage: 35 to 95 %RH (no freezing or condensation)
Protection rating	IP67 (IEC standards)
Connection	Cable type model
Wire spec.	Ø 4 mm, 2-wire, 2 m
Connector spec.	AWG 22 (0.08 mm, 60-core), insulator diameter: Ø 1.25 mm
Material	Case: Heat-resistant ABS, standard type cable (black): polyvinyl chloride (PVC)

Dimensions

• Unit: mm, For the detailed drawings, follow the Autonics website.

A	Operation indicator (red)	B	Tap hole
---	---------------------------	---	----------

■ PSN25

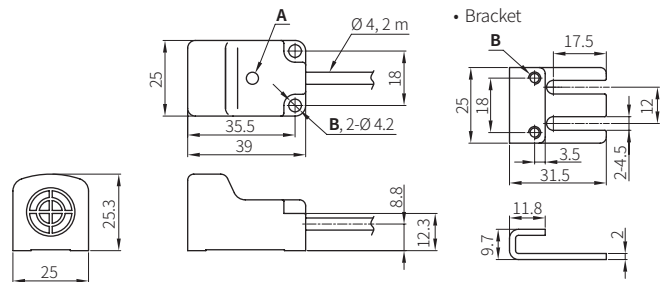

■ PSN30

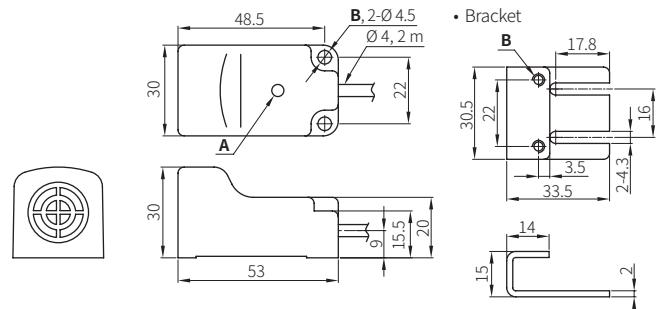

■ PSN40

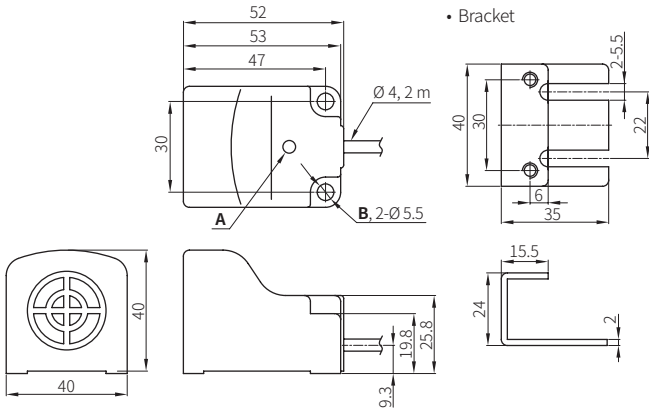

Setting Distance Formula

Detecting distance can be changed by the shape, size or material of the target. For stable sensing, install the unit within the 70% of sensing distance.

Setting distance (Sa)
= Sensing distance (Sn) × 70%

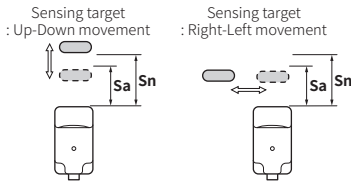

Mutual-interference & Influence by Surrounding Metals

■ Mutual-interference

When plural proximity sensors are mounted in a close row, malfunction of sensor may be caused due to mutual interference. Therefore, be sure to provide a minimum distance between the two sensors, as below table.

[Face to Face]

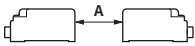

[Parallel]

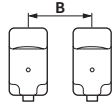

■ Influence by surrounding metals

When sensors are mounted on metallic panel, it must be prevented sensors from being affected by any metallic object except target. Therefore, be sure to provide a minimum distance as below chart.

• Standard type

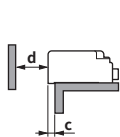

• Upper side type

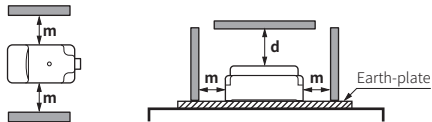

(unit: mm)

Model	PSN25	PSN30-10	PSN30-15	PSN40
A	30	60	90	120
B	40	50	65	70
c	4	5	5	5
d	15	30	45	60
m	20	25	35	35

Sensing Distance Feature Data by Target Material and Size

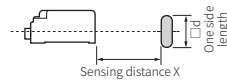

• PSN25

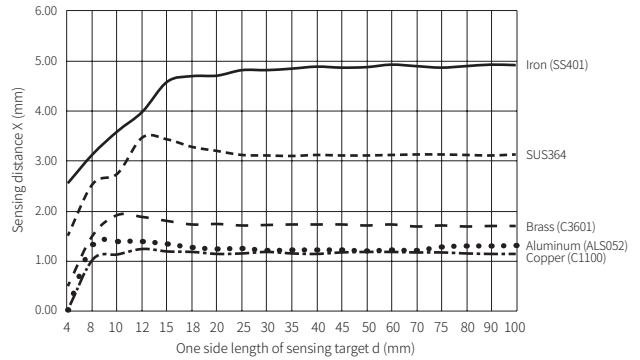

• PSN30-10

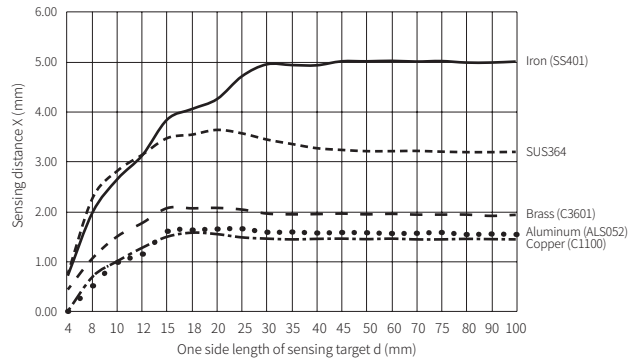

• PSN30-15

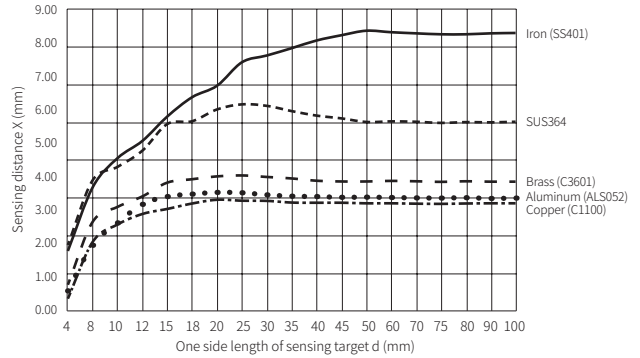

• PSN40

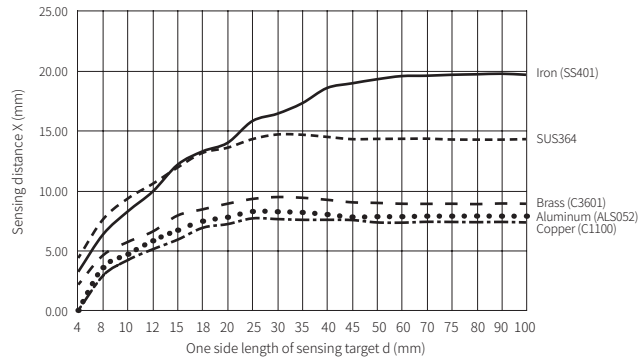

Sensing Distance Feature Data by Parallel (Left/Right) Movement

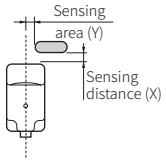

• PSN25

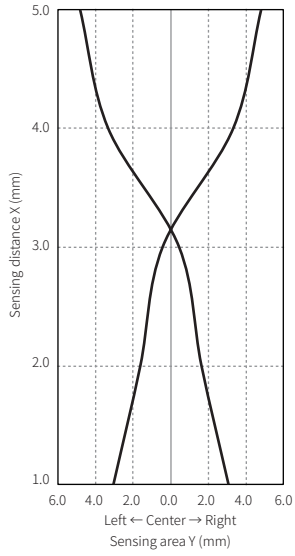

• PSN30

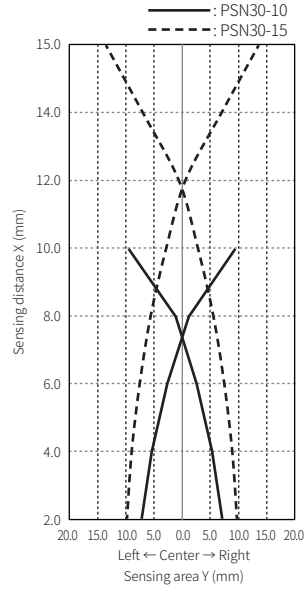

• PSN40

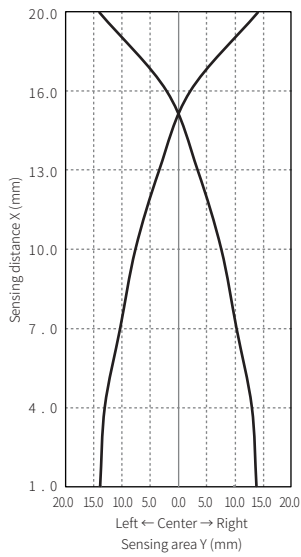

Rectangular Inductive Proximity Sensors

PS Series INSTRUCTION MANUAL

TCD210178AB

Autonics

Thank you for choosing our Autonics product.

Read and understand the instruction manual and manual thoroughly before using the product.

For your safety, read and follow the below safety considerations before using.

For your safety, read and follow the considerations written in the instruction manual, other manuals and Autonics website.

Keep this instruction manual in a place where you can find easily.

The specifications, dimensions, etc. are subject to change without notice for product improvement. Some models may be discontinued without notice.

Follow Autonics website for the latest information.

Safety Considerations

- Observe all 'Safety Considerations' for safe and proper operation to avoid hazards.
- ⚠ symbol indicates caution due to special circumstances in which hazards may occur.

⚠ Warning Failure to follow instructions may result in serious injury or death.

01. Fail-safe device must be installed when using the unit with machinery that may cause serious injury or substantial economic loss. (e.g. nuclear power control, medical equipment, ships, vehicles, railways, aircraft, combustion apparatus, safety equipment, crime/disaster prevention devices, etc.)
Failure to follow this instruction may result in personal injury, economic loss or fire.

02. Do not use the unit in the place where flammable/explosive/corrosive gas, high humidity, direct sunlight, radiant heat, vibration, impact, or salinity may be present.
Failure to follow this instruction may result in explosion or fire.

03. Do not disassemble or modify the unit.
Failure to follow this instruction may result in fire.

04. Do not connect, repair, or inspect the unit while connected to a power source.

Failure to follow this instruction may result in fire.

05. Check 'Connections' before wiring.

Failure to follow this instruction may result in fire.

⚠ Caution Failure to follow instructions may result in injury or product damage.

01. Use the unit within the rated specifications.

Failure to follow this instruction may result in fire or product damage.

02. Use a dry cloth to clean the unit, and do not use water or organic solvent.
Failure to follow this instruction may result in fire.

Cautions during Use

- Follow instructions in 'Cautions during Use'.
- Otherwise, it may cause unexpected accidents.
- 12 - 24 VDC power supply should be insulated and limited voltage/current or Class 2, SELV power supply device.
- Use the product, after 0.8 sec of supplying power.
- Wire as short as possible and keep away from high voltage lines or power lines, to prevent surge and inductive noise.
- Do not use near the equipment which generates strong magnetic force or high frequency noise (transceiver, etc.).
- In case installing the product near the equipment which generates strong surge (motor, welding machine, etc.), use diode or varistor to remove surge.
- This unit may be used in the following environments.
 - Indoors (in the environment condition rated in 'Specifications')
 - Altitude max. 2,000 m
 - Pollution Degree 2
 - Installation Category II

Cautions for Installation

- Install the unit correctly with the usage environment, location, and the designated specifications.
- Do NOT impacts with a hard object or excessive bending of the wire lead-out. It may cause damage the water resistance.
- Do NOT pull the \varnothing 2.5 mm cable with a tensile strength of 20 N, the \varnothing 4 mm cable with a tensile strength of 30 N or over and the \varnothing 5 mm cable with a tensile strength of 50 N or over. It may result in fire due to the broken wire.
- When extending wire, use AWG 22 cable or over within 200 m.
- Refer to the table below for the screw tightening torque when mounting the bracket.

Sensing side length	8 mm	12 mm	50 mm
Tightening torque	0.3 N m	0.49 N m	0.98 N m

Ordering Information

This is only for reference.

For selecting the specific model, follow the Autonics web site.

PS ① - ② D ③ ④

① Sensing side length

Number: Side length of head (unit: mm)

③ Control output

N: NPN Normally Open
N2: NPN Normally Closed
P: PNP Normally Open
P2: PNP Normally Closed

② Sensing distance

Number: Sensing distance (unit: mm)

④ Sensing side

No-mark: Standard type
U: Upper side type

Product Components

Sensing side length	8 mm	12 mm	50 mm
Bracket	1 ×	1 ×	-
Bolt	M3 × 1	M3 × 2	M4 × 4
Nut	M3 × 1	M3 × 2	-
Spring washer	1 ×	-	-
Flat washer	1 ×	-	-

Connections

■ Cable type

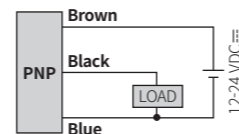
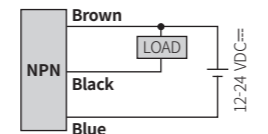

■ Control Output Circuit (NPN output)

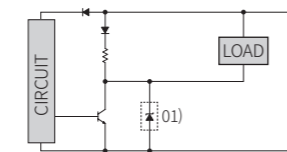

■ Control Output Circuit (PNP output)

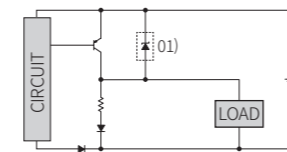

01) Sensing side length 8 mm: except zener diode

Operation Timing Chart

	Normally Open	Normally Closed
Sensing target	Presence Nothing	Presence Nothing
Load	Operation Return	Operation Return
Output voltage	NPN output H L	H L
	PNP output H L	H L
Operation indicator (red)	ON OFF	ON OFF

Specifications

Installation	Standard type / Upper side type		
Model	PS08-2.5D□-□	PS12-4D□-□	PS50-30D□
Sensing side length	8 mm	12 mm	50 mm
Sensing distance	2.5 mm	4 mm	30 mm
Setting distance	0 to 1.75 mm	0 to 2.8 mm	0 to 21 mm
Hysteresis	≤ 10 % of sensing distance (sensing side length 8 mm: ≤ 20 %)		
Standard sensing target: iron	8 × 8 × 1 mm	12 × 12 × 1 mm	90 × 90 × 1 mm
Response frequency ⁰¹⁾	1 kHz	500 Hz	50 Hz
Affection by temperature	≤ ± 10 % for sensing distance at ambient temperature 20 °C (sensing side length 8 mm: ≤ ± 15 %)		
Indicator	Operating indicator (red)		
Approval	CE ENEC	CE ENEC	CE ENEC
Unit weight (package)	≈ 16 g (≈ 30 g)	≈ 62 g (≈ 77 g)	≈ 220 g (≈ 256 g)

01) The response frequency is the average value. The standard sensing target is used and the width is set as 2 times of the standard sensing target, 1/2 of the sensing distance for the distance.

Power supply	12 - 24 VDC (ripple P-P: ≤ 10 %), operating voltage: 10 - 30 VDC
Current consumption	≤ 10 mA
Control output	Sensing side length 8 mm: ≤ 100 mA Sensing side length 12 mm, 50 mm: ≤ 200 mA
Residual voltage	Sensing side length 8 mm: ≤ 1.0 V Sensing side length 12 mm, 50 mm: ≤ 1.5 V
Protection circuit	Surge protection circuit, output short over current protection circuit, reverse polarity protection
Insulation resistance	≥ 50 MΩ (500 VDC megger)
Dielectric strength	Between all terminals and case: 1,500 VAC ~ 50 / 60Hz for 1 minute (sensing side length 8 mm - between all terminals and case: 1,000 VAC ~ 50 / 60Hz for 1 minute)
Vibration	1 mm double amplitude at frequency 10 to 55 Hz in each of X, Y, Z directions for 2 hours
Shock	500 m/s ² (≈ 50 G) X, Y, Z directions for 3 times
Ambient temp.	-25 to 70 %RH, storage: -30 to 80 %RH (no freezing or condensation)
Ambient humi.	35 to 95 %RH, storage: 35 to 95 %RH (no freezing or condensation)
Protection rating	IP67 (IEC standards)
Connection	Cable type
Cable spec.	Sensing side length 8 mm: \varnothing 2.5 mm, 3-wire, 1 m Sensing side length 12 mm: \varnothing 4 mm, 3-wire, 2 m Sensing side length 50 mm: \varnothing 5 mm, 3-wire, 2 m
Wire spec.	\varnothing 2.5 mm cable : AWG 28 (0.08 mm, 19-core), insulator diameter: \varnothing 0.9 mm \varnothing 4 mm, \varnothing 5 mm cable : AWG 22 (0.08 mm, 60-core), insulator diameter: \varnothing 1.25 mm
Material	Sensing side length 8 mm Case: PC, Sensing side length 12 mm Case: Heat-resistant ABS, Sensing side length 50 mm Case: PBT, standard cable (black): polyvinyl chloride (PVC)

Dimensions

• Unit: mm, For the detailed dimensions of the product, follow the Autonics web site.

A Operation indicator (red) **B** Tap hole

■ PS08

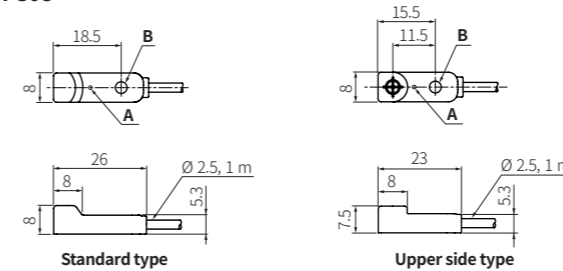

• Bracket

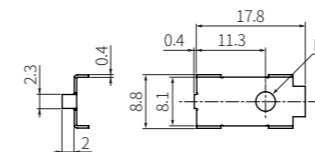

• Mounting hole cut-out

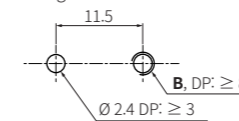

■ PS12

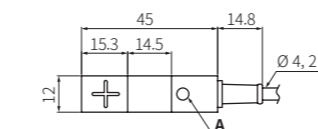

• Bracket

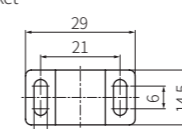

Standard type / Upper side type



■ PS50

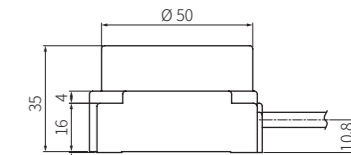
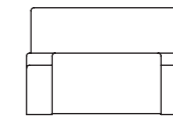
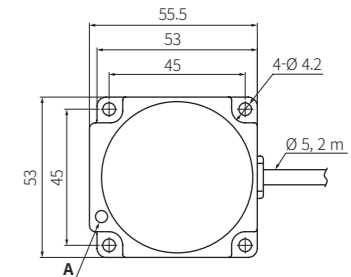

Standard type

Setting Distance Formula

Detecting distance can be changed by the shape, size or material of the target.

For stable sensing, install the unit within the 70 % of sensing distance.

Setting distance (Sa)

= Sensing distance (Sn) × 70 %

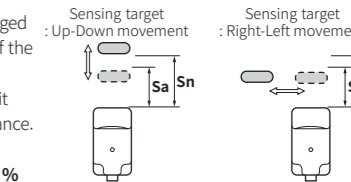

Mutual-interference & Influence by Surrounding Metals

■ Mutual-interference

When plural proximity sensors are mounted in a close row, malfunction of sensor may be caused due to mutual interference.

Therefore, be sure to provide a minimum distance between the two sensors, as below table.

[Face to Face]



[Parallel]

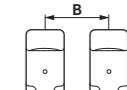

■ Influence by surrounding metals

When sensors are mounted on metallic panel, it must be prevented sensors from being affected by any metallic object except target. Therefore, be sure to provide a minimum distance as below chart.

• Standard type

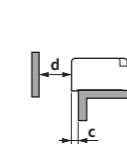

• Upper side type

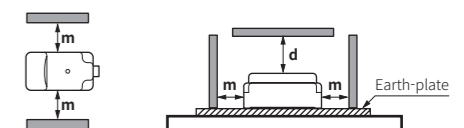

(unit: mm)

Sensing side length	8 mm	12 mm	50 mm
A	16	24	180
B	16	24	130
c	3	5	-
d	15	12	120
m	8	12	50