

# INSTRUCTION MANUAL

## Slim Body Area Sensor NA2-N Series



WARNING

- If this product is used as a sensing device for personnel protection, serious body injury or death could result.
- Never use this product as a sensing device with any press machine, shearing machine, roll grinding machine, forming machine, vulcanizer, or robot etc. for protection of a hand or a part of the body.
- This product does not include a self-checking circuit for safety functions necessary to allow its use as a safety device. Thus, a system failure or malfunction can result in either an energized or a de-energized output condition.
- When this product is used as a sensing device in the following applications and if a problem relating to 'law' or 'product liability' occurs, SUNX shall not be liable for the failure and for the damage or less.
  - 1) Use of this product installed to a machinery or a device as a sensing device to detect a hand or a part of the operator's body entering a dangerous area and stop the machinery or the device.
  - 2) Installation of this product to a protection device for preventing to enter a dangerous area and use of this as a sensing device which detects a hand or a part of the operator's body and open/close the door or window.
  - 3) Use of this product as a sensing device for personnel protection (including interlock).
- For sensing devices to be used as safety devices for press machines or for personnel protection, use products which meet standards, such as OSHA, ANSI or IEC etc., for personnel protection applicable in each region or country.
- In case of using as a safety device for press machines, use a product approved by the Ministry of Labor in Japan.

### 1 SPECIFICATIONS

Item	Model No.	Number of beam channels						
		8	12	16	20	24	28	
		NPN output	NA2-N8	NA2-N12	NA2-N16	NA2-N20	NA2-N24	NA2-N28
		PNP output	NA2-N8-PN	NA2-N12-PN	NA2-N16-PN	NA2-N20-PN	NA2-N24-PN	NA2-N28-PN
Sensing height		140mm	220mm	300mm	380mm	460mm	540mm	
Sensing range		5m						
Beam pitch		20mm						
Sensing object		φ 30mm or more opaque object						
Supply voltage		12 to 24V DC ± 10% Ripple P-P 10% or less						
Power consumption	Emitter	Job indicator ON	0.7W or less	0.8W or less	0.9W or less	1.0W or less	1.1W or less	1.2W or less
		Job indicator OFF	0.6W or less	0.7W or less	0.8W or less	0.9W or less	1.0W or less	1.1W or less
	Receiver	Job indicator ON	0.7W or less	0.8W or less	0.9W or less	1.0W or less	1.1W or less	1.2W or less
		Job indicator OFF	0.6W or less	0.7W or less	0.8W or less	0.9W or less	1.0W or less	1.1W or less
Output			<b>&lt;NPN output type&gt;</b>			<b>&lt;PNP output type&gt;</b>		
			NPN open-collector transistor			PNP open-collector transistor		
			• Maximum sink current: 100mA • Applied voltage: 30V DC or less (between output and 0V) • Residual voltage: 1V or less (at 100mA sink current) 0.4V or less (at 16mA sink current)			• Maximum source current: 100mA • Applied voltage: 30V DC or less (between output and +V) • Residual voltage: 1V or less (at 100mA source current) 0.4V or less (at 16mA source current)		
	Output operation		ON when all beam channels are received (OFF when one or more beam channels are interrupted)					
Short-circuit protection		Incorporated						
Response time		10ms or less (12ms or less when the interference prevention function is used)						
Indicators	Emitter	Emitting indicator: Green LED × 2 (light up when the power is ON; one LED lights up for Frequency A setting, both LEDs light up for Frequency B setting) Job indicator: Red LED (lights up, blinks or lights off when the job indicator input is applied, selected by operation mode switch)						
	Receiver	Operation indicator: Red LED (lights up when one or more beam channels are interrupted) Stable incident beam indicator: Green LED (lights up when all beam channels are stably received) Job indicator: Red LED (lights up, blinks or lights off when the job indicator input is applied, selected by operation mode switch) * When an excess current flows through the output, the stable incident beam indicator and the operation indicator on the receiver blink simultaneously due to the operation of the short-circuit protection circuit.						
Ambient temperature		-10 to +55°C (No dew condensation or icing allowed), Storage: -10 to +60°C						
Ambient humidity		35 to 85% RH, Storage: 35 to 85% RH						
Emitting element		Infrared LED (modulated)						
Material		Enclosure: Heat-resistant ABS, Front cover: Polyacetal, Indicator cover: Acrylic						
Cable		0.2mm <sup>2</sup> 4-core oil-resistant cabtyre cable, 3m long						
Weight (total of the emitter and the receiver)		350g approx.	400g approx.	450g approx.	500g approx.	570g approx.	650g approx.	

### 2 MOUNTING

- Use M4 screws with washers and M4 nuts. The tightening torque should be 0.5N·m or less. During mounting, do not apply any bending or twisting force to the sensor. (Please arrange the screws and nuts separately.)
- Sensor mounting brackets (MS-NA2-1, MS-NA1-1) are also available.

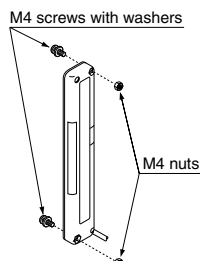

MS-NA2-1 assembly drawing

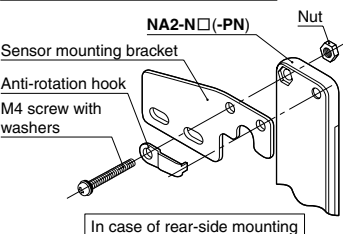

MS-NA1-1 assembly drawing

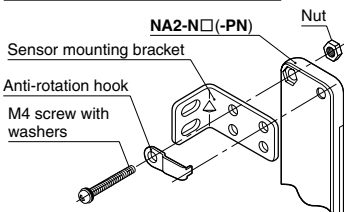

### 3 CAUTIONS

- Make sure that the power supply is off while wiring.
- Take care that wrong wiring may damage the sensor.
- Verify that the supply voltage variation is within the rating.
- If power is supplied from a commercial switching regulator, ensure that the frame ground (F.G.) terminal of the power supply is connected to an actual ground.
- In case noise generating equipment (switching regulator, inverter motor, etc.) is used in the vicinity of this product, connect the frame ground (F.G.) terminal of the equipment to an actual ground.
- Do not run the wires together with high-voltage lines or power lines or put them in the same raceway. This can cause malfunction due to induction.
- Extension up to total 25m is possible, for both emitter and receiver, with 0.2mm<sup>2</sup>, or more, cable. However, in order to reduce noise, make the wiring as short as possible.
- Do not use during the initial transient time (500ms) after the power supply is switched on.
- Avoid dust, dirt, and steam.
- Take care that the sensor does not come in direct contact with water, oil, grease, or organic solvents, such as, thinner, etc.
- Do not use in an environment containing inflammable or explosive gas.
- Make sure to use an isolation transformer for the DC power supply. If an auto-transformer (single winding transformer) is used, this product or the power supply may get damaged.
- In case a surge is generated in the used power supply, connect a surge absorber to the supply and absorb the surge.
- Take care that the sensor is not directly exposed to fluorescent light from a rapid-starter lamp or a high frequency lighting device, as it may affect the sensing performance.
- The emitter and the receiver must face each other with their cable ends on the same side. If they are set upside down, the sensor will not work correctly.
- This sensor is suitable for indoor use only.

### 4 I/O CIRCUIT DIAGRAMS

#### ● NA2-N□ / NPN output type

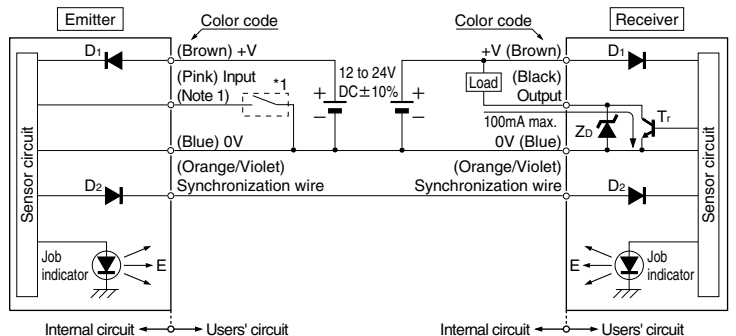

- Notes: 1) The input (pink) is the job indicator input when No. 4 of the operation mode switch on the emitter is set to the 'OFF' side, and it is the test input (emission halt input) when the switch is set to the 'ON' side.  
2) In order to use the job indicator as a large operation indicator, connect the input (pink) of the emitter to the output (black) of the receiver.  
3) When the test input (emission halt input) is set, the job indicator does not light up or blink.

Symbols...D1 : Reverse supply polarity protection diode  
D2 : Reverse current protection diode  
ZD : Surge absorption zener diode  
Tr : NPN output transistor  
E : Job indicator

\*1  
Non-voltage contact or NPN open-collector transistor  
  
Low: 0 to 2V  
High: 5 to 30V, or open

● NA2-N□-PN / PNP output type

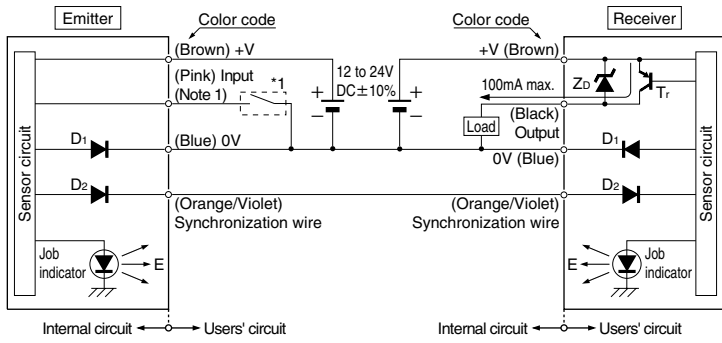

- Notes: 1) The input (pink) is the job indicator input when No. 4 of the operation mode switch on the emitter is set to the 'OFF' side, and it is the test input (emission halt input) when the switch is set to the 'ON' side.  
 2) In order to use the job indicator as a large operation indicator, connect the input (pink) of the emitter to the output (black) of the receiver.  
 3) When the test input (emission halt input) is set, the job indicator does not light up or blink.

- Symbols...D1 : Reverse supply polarity protection diode  
 D2 : Reverse current protection diode  
 Zd : Surge absorption zener diode  
 Tr : PNP output transistor  
 E : Job indicator

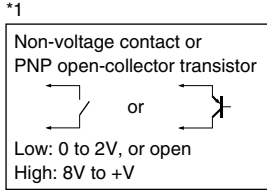

5 PART DESCRIPTION

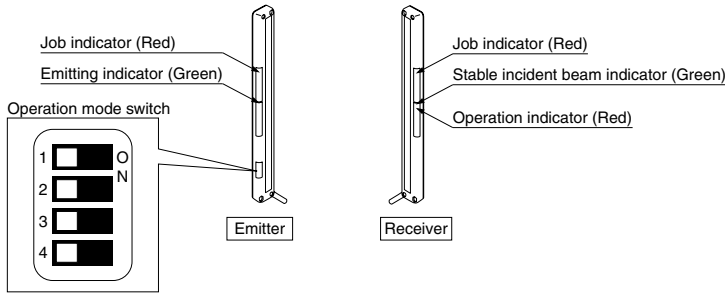

● Operation mode switch

No.	Description	'OFF' side	'ON' side
1	Emission frequency selection	Frequency A	Frequency B
2	Job indicator operation selection	Lights up when job indicator input is Low	Lights off when job indicator input is Low
3	Job indicator operation selection	Lights up	Blinks
4	Operation indicator / test input (emission halt input) selection	Job indicator input	Test input (Emission halt input)

6 JOB INDICATOR OPERATION SELECTION

- The operation of the job indicator can be selected with the job indicator mode switch.

Operation mode switch	Job indicator operation	
	Job indicator input: Low	Job indicator input: High
	Lights up	Lights off
	Lights off	Lights up
	Lights up	Blinks
	Lights off	Blinks

Job indicator input signal condition

Output	Signal	Signal condition
NPN output	Low	0 to 2V
	High	5 to 30V, or open (Note)
PNP output	Low	0 to 2V, or open (Note)
	High	8V to +V

Note: Insulate the wire if it is kept open.

7 IN CASE OF USING JOB INDICATOR AS LARGE OPERATION INDICATOR

- The job indicators can be used as large operation indicators by setting No. 4 of the operation mode switch to the 'OFF' side and connecting the input (pink) of the emitter to the output (black) of the receiver.

Job indicator mode switch	Light state	Dark state
	Lights up	Lights off
	Lights off	Lights up
	Lights up	Blinks
	Lights off	Blinks

Note: In order to use the job indicators as large operation indicators, make sure to set No. 4 of the operation mode switch to the 'OFF' side. If it is set to the 'ON' side, the job indicator does not light up or blink.

8 TEST INPUT (EMISSION HALT INPUT) FUNCTION

- The emission is stopped when No. 4 of the operation mode switch is set to the 'ON' side and the input (pink) of the emitter is made High (PNP output type: Low). Since the output can be turned ON/OFF without the sensing object, this function is useful for start-up inspection. If the output follows the application/withdrawal of the test input (emission halt input), the sensor operation is normal, else it is abnormal.

Operation mode switch setting



Time chart

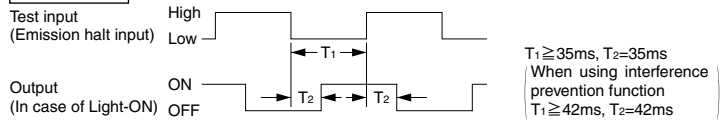

- Notes: 1) When the test input (emission halt input) function is set, the job indicator (red) does not light up or blink.  
 2) When emission is stopped during the test-run function, the emitter's emitting indicator (green) does not light up.

9 INTERFERENCE PREVENTION FUNCTION

- By setting different emission frequencies, two units of NA2-N can be mounted close together, as shown in the figure below. The emission frequency can be checked by the number of LEDs lighting up in the emitting indicator on the emitter.

	Operation mode switch	Emitting indicator (Emitter)
Sensor ①	Frequency A 	One LED lights up
Sensor ②	Frequency B 	Two LEDs light up

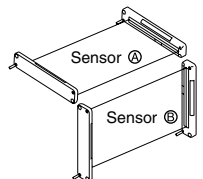

10 BEAM ALIGNMENT

- Place the emitter and the receiver face to face along a straight line.
- After the cables have been correctly connected, switch the power ON.
- Move the emitter in the up, down, left and right directions, in order to determine the range of the beam received condition with the help of the operation indicator on the receiver. Then, set the emitter at the center of this range.
- Similarly, adjust for up, down, left and right angular movement of the emitter.
- Further, perform the angular adjustment for the receiver also.
- Check that the stable incident beam indicator (green) lights up.
- Interrupt each beam channel with the actual sensing object, and confirm that the sensor operates correctly.

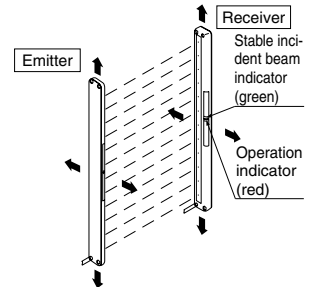

Note: The stable incident beam indicator (green) lights up when all the light beams are stably received.

SUNX Limited

<http://www.sunx.co.jp/>

Head Office  
 2431-1 Ushiyama-cho, Kasugai-shi, Aichi, 486-0901, Japan  
 Phone: +81-(0)568-33-7211 FAX: +81-(0)568-33-2631  
 Overseas Sales Dept.  
 Phone: +81-(0)568-33-7861 FAX: +81-(0)568-33-8591