

66mm Bulb type Warning Signal Light



MENICS
SIGNALTECHNIK

MLG/MLP SERIES

MANUAL

Thank you very much for selecting Menics products. Please read this manual carefully before you use this unit.

Feature

- Bright light by prism cut design of the lens.
- Strong flash by rotation reflector.
- Standard step color: RED , YELLOW , GREEN , BLUE

Ordering Information

MLGF - 10 - R

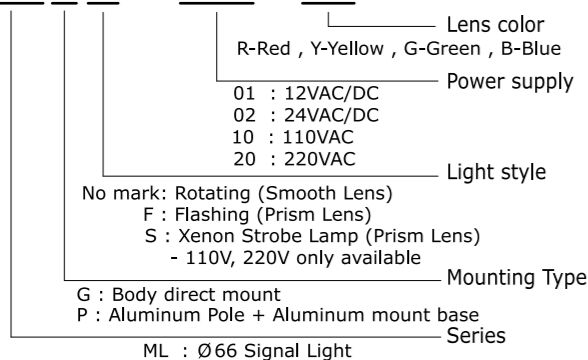

External Dimensions (UNIT : mm)

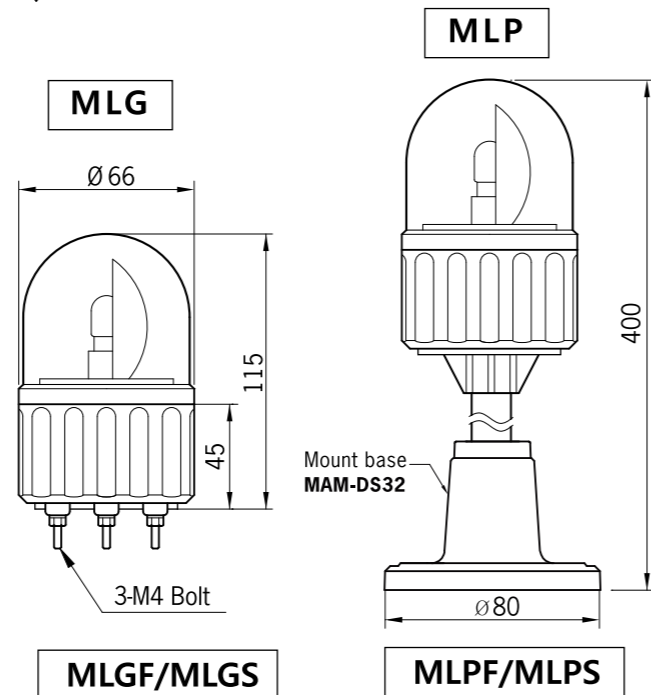

Specification

MODEL	Voltage	Current	Rotation	Bulb
MLG	12VAC/DC	0.67A	130/Min	12V 8W
MLP	24VAC/DC	0.33A		24V 8W
MLG	AC110V	0.07A		130V 8W
MLP	AC220V	0.03A		240V 8W
MLGF	12VDC	0.67A	Flashing 80/Min	12V 8W
MLPF	24VDC	0.33A		24V 8W
MLGF	AC110V	0.07A		130V 8W
MLPF	AC220V	0.03A		240V 8W
MLGS	AC110V	0.22A		
MLPS	AC220V	0.11A		

Bulb Replacement Parts

 Energy Used: 8 watts Base Type: Single Contact (BA15S) Color / Finish: Clear Length: 45mm Width: 16mm	12V type	MAM-T15-S-012-08
	24V type	MAB-T15-S-024-08
	110V type	MAB-T15-S-130-08
	220V type	MAB-T15-S-240-08

Change Bulb

Please follow the procedure mentioned below to change the bulb.

- Make sure power is turned off when changing the lens.
- Remove lens.
- The bulb can be easily removed by pressing it downward to turn to left.
- The new bulb can be easily installed by pressing it downward to turn to right.
- Install lens.

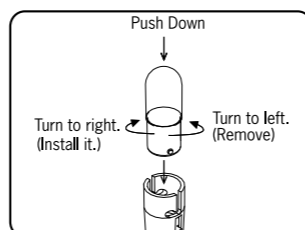

Connection

General type (12 , 24VAC/DC type)

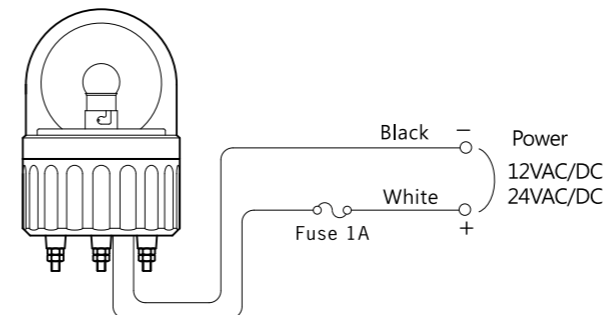

General type (AC type) Xenon Strobe Lamp type

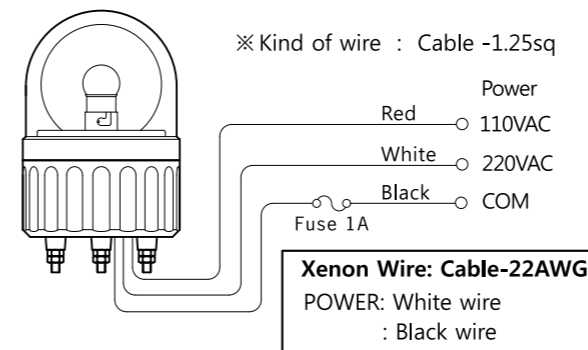

General+Flashing type (12 , 24VDC)

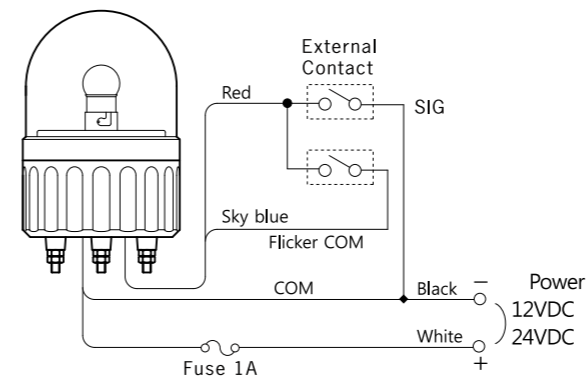

General+Flashing type (AC Type)

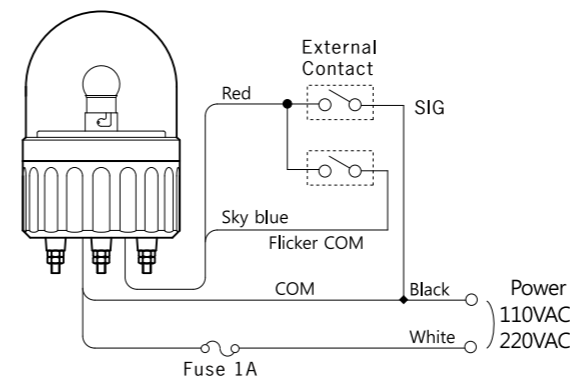

- Do not connect wire between buzzer and flicker common.
- Insulation needed.
- Kind of wire : Signal-0.25sq

Inatallation

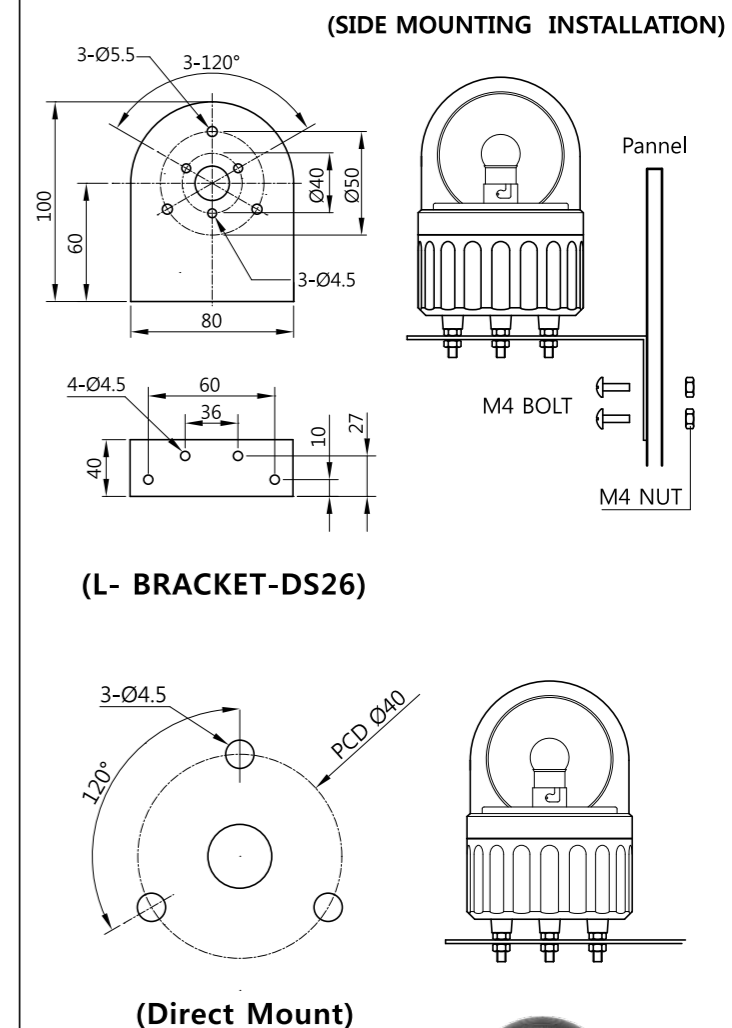

Cautions

- Make sure power is turned off and the temperature of electric bulb falls down for repair to avoid electric shock and burn.
- When you repair this product as color reformation, power must be turned off to avoid electrical shock.
- Follow wiring diagrams carefully. Miswiring could damage the internal circuit, buzzer circuit or cause the unit to be inoperative.
- Check the power voltage with allowable rate.
- Do not expose the tower or any of its component parts to thinners or other strong solvents.
- Do not modify any components or specifications from our standards.
- Never pull on the wire.
- Be sure to use crimp type terminal connectors.
- Do not impact.

MENICS
SIGNALTECHNOLOGY

118-1, Ungbigongdan-gil, Yangsan-si, Gyeongsangnam-do, Korea, 50524
 TEL : 82-55-371-5200 FAX: 82-55-371-5202
 http://www.menics.co.kr E-mail: menics@chol.com