

# Digital Counters / Timers



## FXM / FXH Series PRODUCT MANUAL

**For your safety, read and follow the considerations written in the instruction manual, other manuals and Autonics website.**

The specifications, dimensions, etc. are subject to change without notice for product improvement. Some models may be discontinued without notice.

### Features

- Counting speeds: 1 cps / 30 cps / 2 kcps / 5 kcps
- Switch between counter and timer operation using DIP switch
- No-voltage input (NPN) using DIP switch
- Operation modes: count-up, count-down, count-up / down
- Set decimal point, hr / min / sec display with RESET key

#### [Counter]

- 20 input modes, 18 output modes

#### [Timer]

- Various output modes (16 output modes)
- Various time setting ranges:
  - 8-digit models: 0.01 sec to 99999 hr 59.9 min
  - 6-digit models: 0.1 sec to 99999.9 hr
  - 4-digit models: 0.01 sec to 9999 hr
- Output model types: single preset, dual preset, indicator only
- Power supply: 100 - 240 VAC ~ 50 / 60 Hz

### Safety Considerations

- Observe all 'Safety Considerations' for safe and proper operation to avoid hazards.
- ⚠ symbol indicates caution due to special circumstances in which hazards may occur.

**⚠ Warning** Failure to follow instructions may result in serious injury or death.

- 01. Fail-safe device must be installed when using the unit with machinery that may cause serious injury or substantial economic loss. (e.g. nuclear power control, medical equipment, ships, vehicles, railways, aircraft, combustion apparatus, safety equipment, crime / disaster prevention devices, etc.)**  
Failure to follow this instruction may result in personal injury, economic loss or fire.
- 02. Do not use the unit in the place where flammable / explosive / corrosive gas, humidity, direct sunlight, radiant heat, vibration, impact, or salinity may be present.**  
Failure to follow this instruction may result in explosion or fire.
- 03. Install on a device panel to use.**  
Failure to follow this instruction may result in fire or electric shock.
- 04. Do not connect, repair, or inspect the unit while connected to a power source.**  
Failure to follow this instruction may result in fire or electric shock.
- 05. Check 'Connections' before wiring.**  
Failure to follow this instruction may result in fire.
- 06. Do not disassemble or modify the unit.**  
Failure to follow this instruction may result in fire or electric shock.

**⚠ Caution** Failure to follow instructions may result in injury or product damage.

- 01. When connecting the power / sensor input and relay output, use AWG 20 (0.50 mm<sup>2</sup>) cable or over, and tighten the terminal screw with a tightening torque of 0.74 to 0.90 N m.**  
Failure to follow this instruction may result in fire or malfunction due to contact failure.
- 02. Use the unit within the rated specifications.**  
Failure to follow this instruction may result in fire or product damage.
- 03. Use a dry cloth to clean the unit, and do not use water or organic solvent.**  
Failure to follow this instruction may result in fire or electric shock.
- 04. Keep the product away from metal chip, dust, and wire residue which flow into the unit.**  
Failure to follow this instruction may result in fire or product damage.

### Cautions during Use

- Follow instructions in 'Cautions during Use'.  
Otherwise, it may cause unexpected accidents.
- Use the product, 0.1 sec after supplying power.
- When supplying or turning off the power, use a switch or etc. to avoid chattering.
- Install a power switch or circuit breaker in the easily accessible place for supplying or disconnecting the power.
- When the counter is operating, in case of contact input, set count speed to low speed mode (1 cps or 30 cps) to operate. If set to high speed mode (2 k, 5 kcps) counting error occurs due to chattering.
- Keep away from high voltage lines or power lines to prevent inductive noise. In case installing power line and input signal line closely, use line filter or varistor at power line and shielded wire at input signal line.  
Do not use near the equipment which generates strong magnetic force or high frequency noise.
- This unit may be used in the following environments.
  - Indoors (in the environment condition rated in 'Specifications')
  - Altitude max. 2,000 m
  - Pollution degree 2
  - Installation category II

## Ordering Information

This is only for reference, the actual product does not support all combinations.  
For selecting the specified model, follow the Autonics website.

**FX** ① ② - ③ ④

### ① Display digits

4: 4-digit  
6: 6-digit  
8: 8-digit

### ② Size

M: DIN W 72 × H 72 mm  
H: DIN W 48 × H 96 mm

### ③ Output

1P: 1-stage setting  
2P: 2-stage setting  
I: Indicator

## Product Components

- Product (+ bracket)
- Instruction manual

## Dimensions

Unit: mm, For the detailed drawings, follow the Autonics website.

### ■ FXM

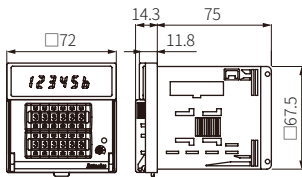

### ■ FXH

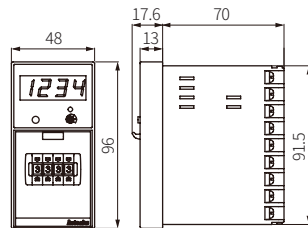

### ■ Bracket

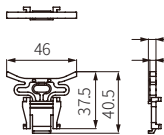

### ■ Panel cut-out

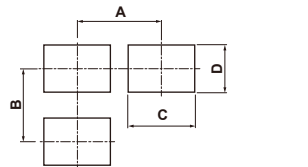

Series	A	B	C	D
FXM	≥ 90	≥ 90	68 <sup>±0.7</sup>	68 <sup>±0.7</sup>
FXH	≥ 65	≥ 115	45 <sup>±0.6</sup>	92 <sup>±0.6</sup>

## Specifications

Model	FX4-□□4	FX6M-□4	FX8M-□4
Display digits	4-digit	6-digit	8-digit
Character size	W 6 × H 10 mm	W 4 × H 8 mm	W 3.8 × H 7.6 mm
Max. counting speed	1 / 30 / 2 k / 5 k cps		
Return time	≤ 500 ms		
Min. signal width	INHIBIT, RESET: ≈ 20 ms		
Input logic	Voltage input (PNP) - input impedance: ≤ 10.8 kΩ, [H]: 5 - 30 VDC≐, [L]: 0 - 2 VDC≐ No-voltage input (NPN) - short-circuit impedance: ≤ 470 Ω, short-circuit residual voltage: ≤ 1 VDC≐ open-circuit impedance: ≥ 100 kΩ		
One-shot output time	Dependent on the output		
1-stage setting	0.05 to 5 sec		
2-stage setting	OUT1: 0.5 sec fixed, OUT2: 0.05 to 5 sec		
Error	Repeat / SET / voltage / Temp.: ≤ ± 0.01 % ± 0.05 s		
Contact control output	Relay		
Type (1-stage)	Instantaneous SPDT (1c) × 1		
Type (2-stage)	Instantaneous SPDT (1c) × 2		
Capacity	250 VAC ~ 3 A, 30 VDC ≐ 3 A resistive load		
Solid-state control output	NPN open collector		
Type (1-stage)	× 1		
Type (2-stage)	× 2		
Capacity	≤ 30 VDC ≐, 100 mA, residual voltage: ≤ 1 VDC ≐		
Unit weight (packaged)	1-stage setting: ≈ 180 g (≈ 245 g) 2-stage setting: ≈ 200 g (≈ 265 g) Indicator: ≈ 160 g (≈ 225 g)		
Approval	CE, RoHS, ENEC		

Power supply	100 - 240 VAC ~ ± 10 % 50 / 60 Hz
Power consumption	Dependent on the output
1-stage setting	≤ 4.6 VA
2-stage setting	≤ 5.8 VA
Indicator	≤ 3.8 VA
External supply power	≤ 12 VDC ≐ ± 10 % 50 mA
Memory retention	≈ 10 years (non-volatile semiconductor memory type)
Insulation resistance	≥ 100 MΩ (500 VDC ≐ megger)
Dielectric strength	Between all terminals and case: 2,000 VAC ~ 50 / 60 Hz for 1 min
Noise immunity	± 2 kV square wave noise (pulse width: 1 μs) by the noise simulator
Vibration	0.75 mm double amplitude at frequency of 10 to 55 Hz (for 1 minute) in each X, Y, Z direction for 1 hour
Vibration (malfunction)	0.5 mm double amplitude at frequency of 10 to 55 Hz (for 1 minute) in each X, Y, Z direction for 10 minute
Shock	300 m/s <sup>2</sup> (≈ 30 G) in each X, Y, Z direction for 3 times
Shock (malfunction)	100 m/s <sup>2</sup> (≈ 10 G) in each X, Y, Z direction for 3 times
Relay life cycle	Mechanical: ≥ 10,000,000 operations Electrical: ≥ 100,000 operations (250 VAC ~ 3 A resistive load)
Ambient temperature	-10 to 55 °C, storage: -25 to 65 °C (no freezing or condensation)
Ambient humidity	35 to 85 %RH, storage: 35 to 85 %RH (no freezing or condensation)
Protection rating	IP20 (front part, IEC standard)

## Connections

### ■ FX□M

#### • 1-stage setting model

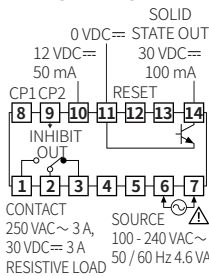

#### • 2-stage setting model

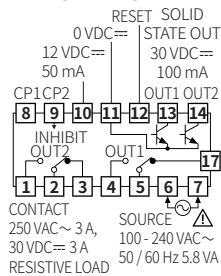

#### • Indicator model

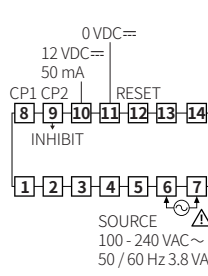

### ■ FX4H

#### • 1-stage setting model

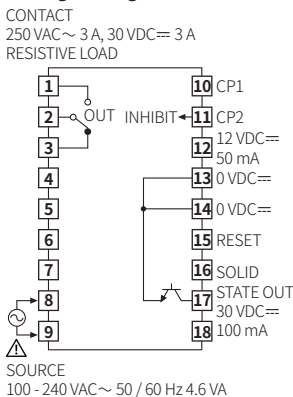

#### • 2-stage setting model

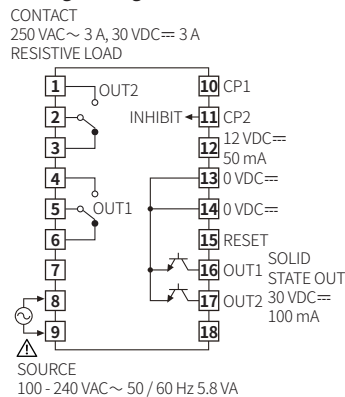

- INHIBIT: In case of timer mode, this terminal is for time hold.  
- Voltage input (PNP): connect with 12 VDC ≐  
- No-voltage input (NPN): connect with 0 VDC ≐

## Mode Setting



### Dot for Decimal Point & Hour / Min / Second

- If there is no RESET key or DIP switch input for 60 sec, it returns to RUN mode.
- [RESET] key: Setting mode ↔ RUN mode  
Move the digit when changing the setting value.

### ■ Decimal point of counter

Parameter	Display	Setting range
C1-1 Setting mode	dP	-
C1-2 Decimal point setting	----	[FX4□-□4] -----, -----, -----
	-----	[FX6M-□4] -----, -----, -----, -----, -----
	-----	[FX8M-□4] -----, -----, -----, -----, -----, -----

### ■ Dot for Hour / Min / Second of timer

Parameter	Display	Setting range	Setting example
T1-1 Setting mode	dP	-	-
T1-2 Setting of dot for Hour / Min / Sec	CLr	CLR: Not divided with dot	5959: 59 m 59 s
		SET: Divided with dot	0.59:59: 59 m 59 s

## Error

- When error occurs, the output turns OFF.
- When 1-stage setting value = 0, OUT1 turns OFF.  
When 2-stage setting value < 1-stage setting value, OUT1 is ignored and only OUT2 operates.
- Indicator model does not have error display function.

Display	Description	Troubleshooting
Err 0	Setting value = 0	Change the setting value anything but 0.

## Output Operation Mode

For the detailed timing chart for operation output mode, refer to the manual.

## Detach the Case or DIP Switch Cover

### ■ FXM

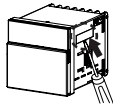

- Push and pull the groove of DIP switch cover with a flat head (-) driver to the front, detaching the cover from the case.

### ■ FXH

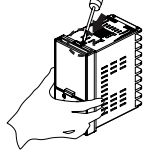

- Push the groove of the front guide with a flat head (-) driver and pull it to the front.
- Pull the front guide to the front. The case is detached. DIP switch is located inside.

⚠ Caution: Turn OFF the power before detaching the cover or case.

⚠ Caution: When using the tools, be careful not to be wounded.

## DIP Switch Setting



- Detach the case or cover of DIP switch and proceed the settings. See the 'Detach the Case or DIP Switch Cover.'
- How to change the settings:  
power OFF → change settings → power ON → press [RESET] key or input the RESET signal ( $\geq 20$  ms) to the external terminal.

### ■ DIP SW1

SW1	Function		Defaults
	Counter	Timer	
1	-		OFF
2	Input operation mode	Time range	OFF
3			OFF
4	Count up / count down		OFF
5, 6, 7	Output operation mode <sup>(01)</sup>		OFF
8	OUT1 One-shot output <sup>(02)</sup>		OFF

01) Except the indicator model.

02) Only for 2-stage setting model.

#### • [Counter] Input operation mode

SW1			Count up / count down & input operation mode	
4	3	2		
OFF	OFF	OFF	Count up	
OFF	OFF	ON		Up / Down - A (command)
OFF	ON	OFF		Up / Down - B (individual)
OFF	ON	ON	Up / Down - C (phase difference)	
ON	OFF	OFF	UP	
ON	OFF	ON	Count down	
ON	ON	OFF		Up / Down - D (command)
ON	ON	ON		Up / Down - E (individual)
ON	ON	ON	Up / Down - F (phase difference)	
ON	ON	ON	Down	

#### • [Timer] Time range

SW1			Time range		
3	2	1	4-digit	6-digit	8-digit
OFF	OFF	OFF	99.99 s	999999.9 s	9999999.99 s
OFF	OFF	ON	999.9 s	999999 s	9999999.9 s
OFF	ON	OFF	9999 s	99 m 59.99 s	99999999 s
OFF	ON	ON	99 m 59 s	999 m 59.9 s	99999 m 59.9 s
ON	OFF	OFF	999.9 m	99999.9 m	9999999.9 m
ON	OFF	ON	99 h 59 m	99 h 59 m 59 s	999 h 59 m 59.9 s
ON	ON	OFF	999.9 h	9999 h 59 m	9999 h 59 m 59 s
ON	ON	ON	9999 h	99999.9 h	99999 h 59.9 m

#### • Input logic

SW2-1	Input logic
ON	NPN (no-voltage input)
OFF	PNP (voltage input)

#### • [Counter] Max. counting speed

SW2		Max. counting speed
3	2	
OFF	ON	1 cps
OFF	OFF	30 cps
ON	OFF	2 kcps
ON	ON	5 kcps

### ■ DIP SW2

SW2	Function		Defaults
	Counter	Timer	
1	CP1, CP2, INHIBIT, RESET input logic		OFF
2	Max. counting speed		OFF
3			OFF
4	Counter / Timer		ON
5	Memory retention		OFF

#### • Output operation mode (1-stage / 2-stage setting model)

SW1			Output operation mode	
7	6	5	Counter	Timer
OFF	OFF	OFF	F	
OFF	OFF	ON	N	
OFF	ON	OFF	C	
OFF	ON	ON	R	
ON	OFF	OFF	K	
ON	OFF	ON	P	
ON	ON	OFF	Q	
ON	ON	ON	S	S

#### • OUT1 One-shot output (2-stage setting model)

SW1-8	OUT1 One-shot output
ON	One-shot
OFF	Hold

## Input Connections

- Input: CP1, CP2 (INHIBIT), RESET
- Max. counting speed in the contact input: 1 or 30 cps setting (counter).

### ■ No-voltage (NPN) input

#### • Solid-state input

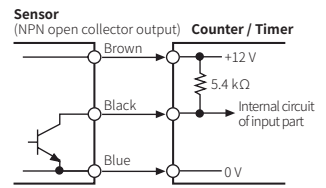
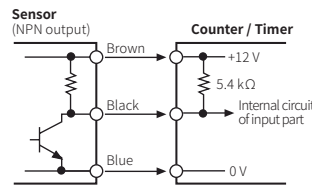

#### • Contact input

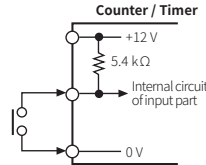

### ■ Voltage (PNP) input

#### • Solid-state input

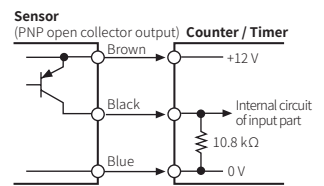
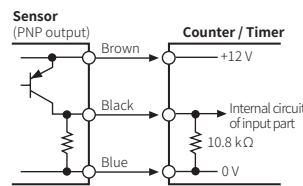

#### • Contact input

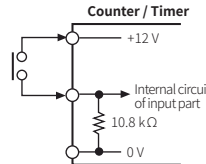

## Input / Output Connections

### When operation load by sensor power

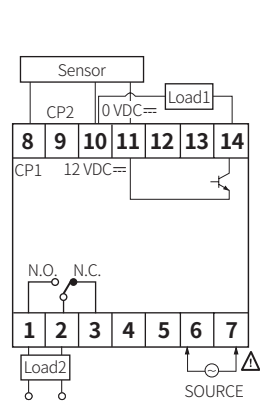

Power for operating load

The sum of operating current capacity of load1 and sensor should not be over external power capacity (50 mA).

### When operating load by external power

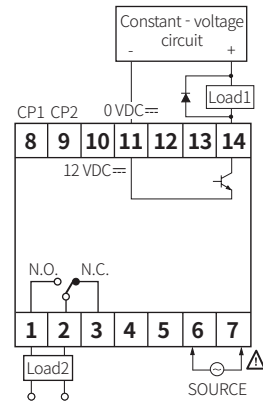

Power for operating load

The capacity of load1 should not be over transistor switching capacity ( $\leq 30 \text{ VDC} \approx 100 \text{ mA}$ ).  
Do not supply the reverse polarity power. When using inductive load (relay, etc.), connector surge absorber at both ends of the load1.

### How to count by external power supply

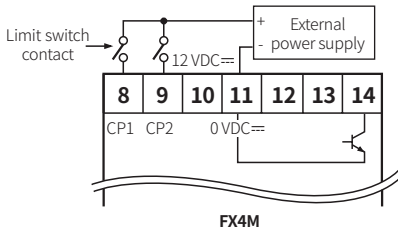

FX4M

This unit starts to count when [H] 5 - 30 VDC is applied at CP1 or CP2 after selecting PNP. ([L]: 0 - 2 VDC)

### Using 2 counters with one sensor

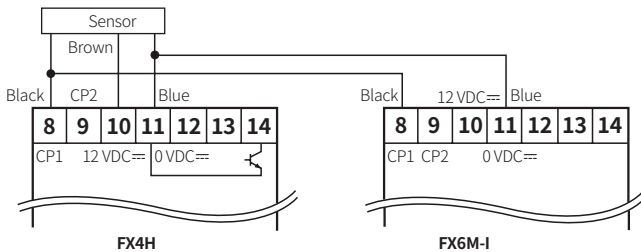

FX4H

FX6M-I

Please connect as the power of sensor is supplied from only one of counters and design input logic with same way.

## Counter Operation

### Input operation mode

Mode	Counting chart <sup>01)</sup>	
	Voltage input (PNP)	No-voltage input (NPN)
Up / Down - A : command input		
Up / Down - B : individual input		
Up / Down - C : phase difference input		
Up : count up input		
Up / Down - D : command input		
Up / Down - E : individual input		
Up / Down - F : phase difference input		
Down : count down input		

01) CP: clock pulse, n: +max. display value

A should be over min. signal width, B is over 1 / 2 of min. signal width. If the signal is smaller than these widths, it may cause counting error ( $\pm 1$ ).

## Output operation mode

- Output type

OUT1' One-shot output (0.5 sec fixed)

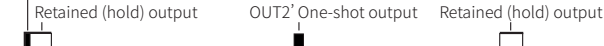

- Set OUT2' One-shot output time via [TIME] volume switch on the front side. setting range: 0.05 to 5 sec

Mode	Output operation description in input operation mode	
	Up, Up / Down - A, B, C	Down, Up / Down - D, E, F
F		
N		
C		
R		
K		
P		
Q		
S		
S		

## Counting operation (for indicator model)

Input operation mode = Up	Input operation mode = Down

## Timer Operation

### Output operation mode

- Output type

OUT1' One-shot output (0.5 sec fixed)

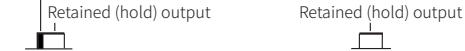

Mode	Output operation description in input operation mode	
	Up, Up / Down - A, B, C	Down, Up / Down - D, E, F
S		

Output turns OFF → ON → OFF repeatedly (flicker).

### Time operation (for indicator model)

Input operation mode = Up, Up / Down - A, B, C	Input operation mode = Down, Up / Down - D, E, F

## Segment Table

The segments displayed on the product indicate the following meanings. It may differ depending on the product.

7 segment	11 segment	12 segment	16 segment
0 0	0 0	0 0	0 0
1 1	1 1	1 1	1 1
2 2	2 2	2 2	2 2
3 3	3 3	3 3	3 3
4 4	4 4	4 4	4 4
5 5	5 5	5 5	5 5
6 6	6 6	6 6	6 6
7 7	7 7	7 7	7 7
8 8	8 8	8 8	8 8
9 9	9 9	9 9	9 9
A A	A A	A A	A A
b B	b B	b B	b B
c C	c C	c C	c C
d D	d D	d D	d D
E E	E E	E E	E E
F F	F F	F F	F F
G G	G G	G G	G G
H H	H H	H H	H H