

# YASKAWA AC Drive E1000

## AC Drive for Fan and Pump

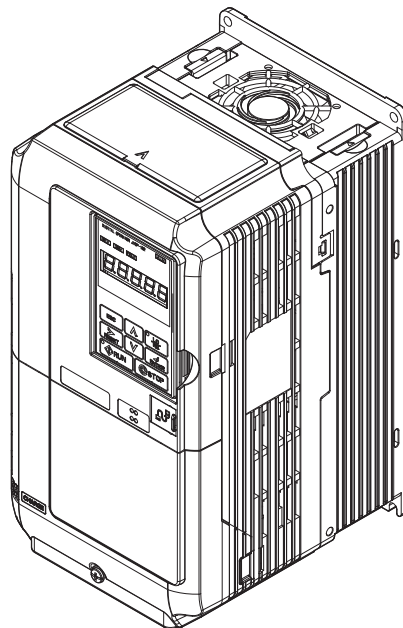
### Technical Manual

Type: CIMR-EB□A [ ] , CIMR-ET□A [ ]

Models: 200 V Class: 0.75 to 110 kW

400 V Class: 0.75 to 630 kW

To properly use the product, read this manual thoroughly and retain for easy reference, inspection, and maintenance. Ensure the end user receives this manual.



Receiving **1**

Mechanical Installation **2**

Electrical Installation **3**

Start-Up Programming & Operation **4**

Parameter Details **5**

Troubleshooting **6**

Periodic Inspection & Maintenance **7**

Peripheral Devices & Options **8**

Specifications **A**

Parameter List **B**

MEMOBUS/Modbus Communications **C**

Standards Compliance **D**

Quick Reference Sheet **E**

---

Copyright © 2009 YASKAWA ELECTRIC CORPORATION.

All rights reserved. No part of this publication may be reproduced, stored in a retrieval system, or transmitted, in any form, or by any means, mechanical, electronic, photocopying, recording, or otherwise, without the prior written permission of Yaskawa. No patent liability is assumed with respect to the use of the information contained herein. Moreover, because Yaskawa is constantly striving to improve its high-quality products, the information contained in this manual is subject to change without notice. Every precaution has been taken in the preparation of this manual. Nevertheless, Yaskawa assumes no responsibility for errors or omissions. Neither is any liability assumed for damages resulting from the use of the information contained in this publication.

## ◆ Quick Reference

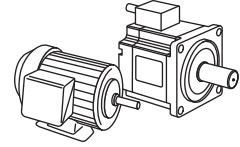
### Easily Set Parameters for Specific Applications

Preset parameter defaults are available for setting up applications. [Refer to Application Selection on page 111.](#)



### Drive a Synchronous PM Motor

E1000 can operate synchronous PM motors. [Refer to Subchart A-2: Operation with Permanent Magnet Motors on page 109.](#)



### Perform Auto-Tuning

Automatic tuning sets motor parameters. [Refer to Auto-Tuning on page 113.](#)

### Maintenance Check Using Drive Monitors

Use drive monitors to check the if fans, capacitors, and other components may require maintenance. [Refer to Performance Life Monitors Maintenance Monitors on page 301.](#)

### Fault Display and Troubleshooting

[Refer to Drive Alarms, Faults, and Errors on page 260](#) and [Refer to Troubleshooting without Fault Display on page 289.](#)

### Standards Compliance

[Refer to European Standards on page 440.](#)  
[Refer to UL Standards on page 446.](#)  
[Refer to Precautions for Korean Radio Waves Act on page 458.](#)





# Table of Contents

---

Quick Reference .....	3
<b>I. PREFACE &amp; GENERAL SAFETY .....</b>	<b>13</b>
<b>i.1 Preface .....</b>	<b>14</b>
Applicable Documentation .....	14
Symbols .....	14
Terms and Abbreviations .....	14
<b>i.2 General Safety .....</b>	<b>15</b>
Supplemental Safety Information .....	15
Safety Messages .....	16
Application Notes .....	18
Notes on Motor Operation .....	20
Applications with Specialized Motors .....	21
Drive Label Warnings .....	22
Warranty Information .....	23
<b>1. RECEIVING .....</b>	<b>25</b>
<b>1.1 Section Safety .....</b>	<b>26</b>
<b>1.2 General Description .....</b>	<b>27</b>
E1000 Model Selection .....	27
Control Mode Selection .....	28
<b>1.3 Model Number and Nameplate Check .....</b>	<b>29</b>
Nameplate .....	29
Model Number .....	29
<b>1.4 Drive Models and Enclosure Types .....</b>	<b>31</b>
<b>1.5 Component Names .....</b>	<b>32</b>
IP20/NEMA Type 1 Enclosure .....	32
IP00 Enclosure .....	33
Front Views .....	39
<b>2. MECHANICAL INSTALLATION .....</b>	<b>41</b>
<b>2.1 Section Safety .....</b>	<b>42</b>
<b>2.2 Mechanical Installation .....</b>	<b>44</b>
Installation Environment .....	44
Installation Orientation and Spacing .....	44
Instructions on Installation of Models CIMR-E□4A0930 and 4A1200 .....	46
Digital Operator Remote Usage .....	47
Exterior and Mounting Dimensions .....	49
<b>3. ELECTRICAL INSTALLATION.....</b>	<b>55</b>
<b>3.1 Section Safety .....</b>	<b>56</b>

<b>3.2</b>	<b>Standard Connection Diagram</b>	<b>58</b>
<b>3.3</b>	<b>Main Circuit Configurations</b>	<b>61</b>
	12-Phase Rectification	62
<b>3.4</b>	<b>Terminal Block Configuration</b>	<b>64</b>
<b>3.5</b>	<b>Terminal Cover</b>	<b>66</b>
	CIMR-E□2A0004 to 0081, 4A0002 to 0044 (IP20/NEMA Type 1 Enclosure)	66
	CIMR-E□2A0110 to 4A0415, 4A0058 to 4A1200 (IP00 Enclosure)	67
<b>3.6</b>	<b>Digital Operator and Front Cover</b>	<b>68</b>
	Removing/Reattaching the Digital Operator	68
	Removing/Reattaching the Front Cover	68
<b>3.7</b>	<b>Top Protective Cover</b>	<b>71</b>
	Removing the Top Protective Cover	71
	Reattaching the Top Protective Cover	71
<b>3.8</b>	<b>Main Circuit Wiring</b>	<b>72</b>
	Main Circuit Terminal Functions	72
	Protecting Main Circuit Terminals	72
	Wire Gauges and Tightening Torque	73
	Main Circuit Terminal and Motor Wiring	77
<b>3.9</b>	<b>Control Circuit Wiring</b>	<b>79</b>
	Control Circuit Connection Diagram	79
	Control Circuit Terminal Block Functions	80
	Terminal Configuration	82
	Wiring the Control Circuit Terminal	83
	Switches and Jumpers on the Terminal Board	84
<b>3.10</b>	<b>Control I/O Connections</b>	<b>85</b>
	Sinking/Sourcing Mode Selection for Hardwire Baseblock Inputs	85
	Using the Contact Outputs	85
	Using the Pulse Train Output	86
	Terminal A2 Input Signal Selection	86
	Terminal A3 Analog/PTC Input Selection	87
	Terminal AM/FM Signal Selection	87
	MEMOBUS/Modbus Termination	87
<b>3.11</b>	<b>Terminal A2 Analog Input Signal Selection</b>	<b>88</b>
	Terminal A2 Input Signal Selection	88
<b>3.12</b>	<b>Connect to a PC</b>	<b>89</b>
<b>3.13</b>	<b>MEMOBUS/Modbus Termination</b>	<b>90</b>
<b>3.14</b>	<b>External Interlock</b>	<b>91</b>
	Drive Ready	91
<b>3.15</b>	<b>Wiring Checklist</b>	<b>92</b>
<b>4.</b>	<b>START-UP PROGRAMMING &amp; OPERATION</b>	<b>95</b>
<b>4.1</b>	<b>Section Safety</b>	<b>96</b>
<b>4.2</b>	<b>Using the Digital Operator</b>	<b>97</b>
	Keys and Displays	97
	Digital Text Display	98
	LED Screen Displays	98
	LO/RE LED and RUN LED Indications	99
	Menu Structure for Digital Operator	100
<b>4.3</b>	<b>The Drive and Programming Modes</b>	<b>101</b>
	Navigating the Drive and Programming Modes	101
	Changing Parameter Settings or Values	103
	Verifying Parameter Changes: Verify Menu	104
	Simplified Setup Using the Setup Group	104
	Switching Between LOCAL and REMOTE	106

<b>4.4 Start-Up Flowcharts</b>	<b>107</b>
Flowchart A: Basic Start-up and Motor Tuning	107
Subchart A-1: Simple Motor Setup Using V/f Control	108
Subchart A-2: Operation with Permanent Magnet Motors	109
<b>4.5 Powering Up the Drive</b>	<b>110</b>
Powering Up the Drive and Operation Status Display	110
<b>4.6 Application Selection</b>	<b>111</b>
Setting 1: Water Supply Pump Application	111
Setting 3: Exhaust Fan Application	111
Setting 4: HVAC Fan Application	112
Setting 5: Compressor Application	112
<b>4.7 Auto-Tuning</b>	<b>113</b>
Types of Auto-Tuning	113
Before Auto-Tuning the Drive	114
Auto-Tuning Interruption and Fault Codes	115
Auto-Tuning Operation Example	115
Parameter Settings during Induction Motor Auto-Tuning: T1	116
Parameter Settings during PM Motor Auto-Tuning: T2	118
<b>4.8 No-Load Operation Test Run</b>	<b>120</b>
No-Load Operation Test Run	120
<b>4.9 Test Run with Load Connected</b>	<b>121</b>
Test Run with the Load Connected	121
<b>4.10 Verifying Parameter Settings and Backing Up Changes</b>	<b>122</b>
Backing Up Parameter Values: o2-03	122
Parameter Access Level: A1-01	122
Password Settings: A1-04, A1-05	122
Copy Function	123
<b>4.11 Test Run Checklist</b>	<b>124</b>
<b>5. PARAMETER DETAILS</b>	<b>125</b>
<b>5.1 A: Initialization</b>	<b>126</b>
A1: Initialization	126
A2: User Parameters	129
<b>5.2 b: Application</b>	<b>131</b>
b1: Operation Mode Selection	131
b2: DC Injection Braking and Short Circuit Braking	137
b3: Speed Search	139
b4: Delay Timers	144
b5: PI Control	145
b8: Energy Saving	158
<b>5.3 C: Tuning</b>	<b>160</b>
C1: Acceleration and Deceleration Times	160
C2: S-Curve Characteristics	162
C4: Torque Compensation	162
C6: Carrier Frequency	163
<b>5.4 d: Reference Settings</b>	<b>165</b>
d1: Frequency Reference	165
d2: Frequency Upper/Lower Limits	166
d3: Jump Frequency	167
d4: Frequency Reference Hold Function	167
d6: Field Weakening and Field Forcing	169
d7: Offset Frequency	169
<b>5.5 E: Motor Parameters</b>	<b>170</b>
E1: V/f Pattern	170
E2: Motor Parameters	174

E5: PM Motor Settings .....	176
<b>5.6 F: Option Settings .....</b>	<b>179</b>
F6: Communication Option Card .....	179
CC-Link Parameters .....	180
MECHATROLINK Parameters .....	180
PROFIBUS-DP Parameters .....	180
CANopen Parameters .....	180
DeviceNet Parameters .....	180
<b>5.7 H: Terminal Functions .....</b>	<b>181</b>
H1: Multi-Function Digital Inputs .....	181
H2: Multi-Function Digital Outputs .....	190
H3: Multi-Function Analog Inputs .....	199
H4: Multi-Function Analog Outputs .....	205
H5: MEMOBUS/Modbus Serial Communication .....	206
H6: Pulse Train Input/Output .....	206
<b>5.8 L: Protection Functions .....</b>	<b>209</b>
L1: Motor Protection .....	209
L2: Momentary Power Loss Ride-Thru .....	214
L3: Stall Prevention .....	221
L4: Speed Detection .....	227
L5: Fault Restart .....	228
L6: Torque Detection .....	231
L8: Drive Protection .....	233
<b>5.9 n: Special Adjustments .....</b>	<b>240</b>
n1: Hunting Prevention .....	240
n3: High Slip Braking (HSB) and Overexcitation Braking .....	241
n8: PM Motor Control Tuning .....	243
<b>5.10 o: Operator Related Settings .....</b>	<b>246</b>
o1: Digital Operator Display Selection .....	246
o2: Digital Operator Keypad Functions .....	247
o3: Copy Function .....	249
o4: Maintenance Monitor Settings .....	250
q: DriveWorksEZ Parameters .....	252
r: DriveWorksEZ Connection Parameters .....	252
T: Motor Tuning .....	252
<b>5.11 U: Monitor Parameters .....</b>	<b>253</b>
U1: Operation Status Monitors .....	253
U2: Fault Trace .....	253
U3: Fault History .....	253
U4: Maintenance Monitors .....	253
U5: PI Monitors .....	253
U6: Operation Status Monitors .....	253
U8: DriveWorksEZ Monitors .....	254
<b>6. TROUBLESHOOTING.....</b>	<b>255</b>
<b>6.1 Section Safety.....</b>	<b>256</b>
<b>6.2 Motor Performance Fine-Tuning.....</b>	<b>258</b>
Fine-Tuning V/f Control .....	258
Fine-Tuning Open Loop Vector Control for PM Motors .....	258
Parameters to Minimize Motor Hunting and Oscillation .....	259
<b>6.3 Drive Alarms, Faults, and Errors .....</b>	<b>260</b>
Types of Alarms, Faults, and Errors .....	260
Alarm and Error Displays .....	261
<b>6.4 Fault Detection .....</b>	<b>265</b>
Fault Displays, Causes, and Possible Solutions .....	265



<b>6.5 Alarm Detection</b> .....	<b>275</b>
Alarm Codes, Causes, and Possible Solutions .....	275
<b>6.6 Operator Programming Errors</b> .....	<b>280</b>
oPE Codes, Causes, and Possible Solutions .....	280
<b>6.7 Auto-Tuning Fault Detection</b> .....	<b>283</b>
Auto-Tuning Codes, Causes, and Possible Solutions .....	283
<b>6.8 Copy Function Related Displays</b> .....	<b>285</b>
Tasks, Errors, and Troubleshooting .....	285
<b>6.9 Diagnosing and Resetting Faults</b> .....	<b>287</b>
Fault Occurs Simultaneously with Power Loss .....	287
If the Drive Still has Power After a Fault Occurs .....	287
Viewing Fault Trace Data After Fault .....	287
Fault Reset Methods .....	288
<b>6.10 Troubleshooting without Fault Display</b> .....	<b>289</b>
Common Problems .....	289
Cannot Change Parameter Settings .....	289
Motor Does Not Rotate Properly after Pressing RUN Button or after Entering External Run Command .....	290
Motor is Too Hot .....	291
Drive Does Not Allow Selection the Desired Auto-Tuning Mode .....	291
oPE02 Error Occurs When Lowering the Motor Rated Current Setting .....	291
Motor Stalls during Acceleration or Acceleration Time is Too Long .....	291
Drive Frequency Reference Differs from the Controller Frequency Reference Command .....	292
Excessive Motor Oscillation and Erratic Rotation .....	292
Deceleration Takes Longer Than Expected with Dynamic Braking Enabled .....	292
Noise From Drive or Motor Cables When the Drive is Powered On .....	292
Earth Leakage Circuit Breaker (ELCB) Trips During Run .....	292
Connected Machinery Vibrates When Motor Rotates .....	293
PI Output Fault .....	293
Motor Rotates After the Drive Output is Shut Off (Motor Rotates During DC Injection Braking) .....	293
Output Frequency is not as High as Frequency Reference .....	293
Buzzing Sound from Motor at 2 kHz .....	293
Unstable Motor Speed when Using PM .....	294
Motor Does Not Restart after Power Loss .....	294
<b>7. PERIODIC INSPECTION &amp; MAINTENANCE</b> .....	<b>295</b>
<b>7.1 Section Safety</b> .....	<b>296</b>
<b>7.2 Inspection</b> .....	<b>299</b>
Recommended Daily Inspection .....	299
Recommended Periodic Inspection .....	300
<b>7.3 Periodic Maintenance</b> .....	<b>301</b>
Replacement Parts .....	301
<b>7.4 Cooling Fan and Circulation Fan</b> .....	<b>303</b>
Number of Fan .....	303
Cooling Fan Component Names .....	303
Cooling Fan Replacement: 2A0018 to 2A0081 and 4A0007 to 4A0044 .....	305
Cooling Fan Replacement: 2A0110 and 2A0138, 4A0058 and 4A0072 .....	307
Cooling Fan Replacement: 4A0088 and 4A0103 .....	309
Cooling Fan Replacement: 2A0169 to 0415, 4A0139 to 4A0362 .....	311
Cooling Fan Replacement: 4A0414 .....	315
Cooling Fan Replacement: 4A0515 and 4A0675 .....	317
Cooling Fan Replacement: 4A0930 and 4A1200 .....	320

7.5 Replacing the Air Filter .....	325
Air Filter Replacement .....	325
7.6 Drive Replacement .....	327
Serviceable Parts .....	327
Terminal Board .....	327
Replacing the Drive .....	328
<b>8. Peripheral Devices &amp; OPTIONS .....</b>	<b>331</b>
<b>8.1 Section Safety .....</b>	<b>332</b>
<b>8.2 Drive Options and Peripheral Devices .....</b>	<b>333</b>
<b>8.3 Connecting Peripheral Devices .....</b>	<b>335</b>
<b>8.4 Option Card Installation .....</b>	<b>336</b>
Prior to Installing the Option .....	336
Installing the Option .....	337
<b>8.5 Installing Peripheral Devices .....</b>	<b>340</b>
Dynamic Braking Options .....	340
Installing a Molded Case Circuit Breaker (MCCB) and Earth Leakage Circuit Breaker (ELCB) .....	341
Installing a Magnetic Contactor at the Power Supply Side .....	342
Connecting an AC or DC Reactor .....	342
Connecting a Surge Absorber .....	343
Connecting a Noise Filter .....	343
Fuse/Fuse Holder .....	345
Attachment for External Heatsink (IP00/NEMA type1 Enclosure) .....	346
EMC Filter Installation .....	346
Installing a Motor Thermal Overload (oL) Relay on the Drive Output .....	346
<b>A. SPECIFICATIONS .....</b>	<b>349</b>
<b>A.1 Three-Phase 200 V Class Drives .....</b>	<b>350</b>
<b>A.2 Three-Phase 400 V Class Drives .....</b>	<b>351</b>
<b>A.3 Drive Specifications .....</b>	<b>352</b>
<b>A.4 Drive Watt Loss Data .....</b>	<b>353</b>
<b>A.5 Drive Derating Data .....</b>	<b>354</b>
Carrier Frequency Derating .....	354
Temperature Derating .....	355
Altitude Derating .....	356
<b>B. PARAMETER LIST .....</b>	<b>357</b>
<b>B.1 Understanding the Parameter Table .....</b>	<b>358</b>
Control Modes, Symbols, and Terms .....	358
<b>B.2 Parameter Groups .....</b>	<b>359</b>
Parameter Differences for models CIMR-E□4A0930 and 4A1200 .....	359
<b>B.3 Parameter Table .....</b>	<b>360</b>
A: Initialization Parameters .....	360
b: Application .....	361
C: Tuning .....	366
d: Reference Settings .....	367
E: Motor Parameters .....	368
F: Options .....	371
H Parameters: Multi-Function Terminals .....	373
L: Protection Function .....	382
n: Special Adjustments .....	387
o: Operator Related Settings .....	388
q: DriveWorksEZ Parameters .....	390
r: DriveWorksEZ Connection Parameters .....	390

T: Motor Tuning .....	390
U: Monitors .....	391
<b>B.4 Control Mode Dependent Parameter Default Values .....</b>	<b>398</b>
A1-02 Dependent Parameters .....	398
<b>B.5 V/f Pattern Default Values .....</b>	<b>399</b>
<b>B.6 Defaults by Drive Model Selection (o2-04) .....</b>	<b>400</b>
<b>B.7 Parameters that Change with the Motor Code Selection .....</b>	<b>404</b>
YASKAWA SMRA Series SPM Motor .....	404
YASKAWA SSR1 Series IPM Motor (For Derated Torque) .....	405
<b>C. MEMOBUS/MODBUS COMMUNICATIONS .....</b>	<b>411</b>
<b>C.1 MEMOBUS/Modbus Configuration .....</b>	<b>412</b>
<b>C.2 Communication Specifications .....</b>	<b>413</b>
<b>C.3 Connecting to a Network .....</b>	<b>414</b>
Network Cable Connection .....	414
Wiring Diagram for Multiple Connection .....	414
Network Termination .....	415
<b>C.4 MEMOBUS/Modbus Setup Parameters .....</b>	<b>416</b>
MEMOBUS/Modbus Serial Communication .....	416
<b>C.5 Drive Operations by MEMOBUS/Modbus .....</b>	<b>419</b>
Observing the Drive Operation .....	419
Controlling the Drive .....	419
<b>C.6 Communications Timing .....</b>	<b>420</b>
Command Messages from Master to Drive .....	420
Response Messages from Drive to Master .....	420
<b>C.7 Message Format .....</b>	<b>421</b>
Message Content .....	421
Slave Address .....	421
Function Code .....	421
Data .....	421
Error Check .....	421
<b>C.8 Message Examples .....</b>	<b>423</b>
Reading Drive MEMOBUS/Modbus Register Contents .....	423
Loopback Test .....	423
Writing to Multiple Registers .....	424
<b>C.9 MEMOBUS/Modbus Data Table .....</b>	<b>425</b>
Command Data .....	425
Monitor Data .....	426
Broadcast Messages .....	432
Fault Trace Contents .....	432
Alarm Register Contents .....	433
<b>C.10 Enter Command .....</b>	<b>434</b>
Enter Command Types .....	434
H5-11 and the Enter Command .....	434
<b>C.11 Communication Errors .....</b>	<b>435</b>
MEMOBUS/Modbus Error Codes .....	435
Slave Not Responding .....	435
<b>C.12 Self-Diagnostics .....</b>	<b>436</b>
<b>D. STANDARDS COMPLIANCE .....</b>	<b>437</b>
<b>D.1 Section Safety .....</b>	<b>438</b>
<b>D.2 European Standards .....</b>	<b>440</b>
CE Low Voltage Directive Compliance .....	440
EMC Guidelines Compliance .....	441

---

<b>D.3 UL Standards</b> .....	<b>446</b>
UL Standards Compliance .....	446
Drive Motor Overload Protection .....	455
Precautionary Notes on External Heatsink (IP00 Enclosure) .....	456
<b>D.4 Precautions for Korean Radio Waves Act.</b> .....	<b>458</b>
<b>D.5 한국 전파법에 관한 주의사항</b> .....	<b>459</b>
<b>E. QUICK REFERENCE SHEET</b> .....	<b>461</b>
<b>E.1 Drive and Motor Specifications</b> .....	<b>462</b>
Drive .....	462
Motor .....	462
<b>E.2 Multi-Function I/O Terminal Settings Record</b> .....	<b>463</b>
Multi-Function Digital Inputs (SC Common) .....	463
Pulse Train Input/Analog Inputs (AC Common) .....	463
Multi-Function Digital Outputs .....	463
Monitor Outputs (AC Common) .....	463
<b>E.3 User Setting Table</b> .....	<b>464</b>
<b>Index</b> .....	<b>468</b>
<b>Revision History</b> .....	<b>479</b>

# Preface & General Safety

---

This section provides safety messages pertinent to this product that, if not heeded, may result in fatality, personal injury, or equipment damage. Yaskawa is not responsible for the consequences of ignoring these instructions.

<b>I.1 PREFACE</b> .....	<b>14</b>
<b>I.2 GENERAL SAFETY</b> .....	<b>15</b>

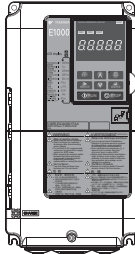
# i.1 Preface

Yaskawa manufactures products used as components in a wide variety of industrial systems and equipment. The selection and application of Yaskawa products remain the responsibility of the equipment manufacturer or end user. Yaskawa accepts no responsibility for the way its products are incorporated into the final system design. Under no circumstances should any Yaskawa product be incorporated into any product or design as the exclusive or sole safety control. Without exception, all controls should be designed to detect faults dynamically and fail safely under all circumstances. All systems or equipment designed to incorporate a product manufactured by Yaskawa must be supplied to the end user with appropriate warnings and instructions as to the safe use and operation of that part. Any warnings provided by Yaskawa must be promptly provided to the end user. Yaskawa offers an express warranty only as to the quality of its products in conforming to standards and specifications published in the Yaskawa manual. **NO OTHER WARRANTY, EXPRESSED OR IMPLIED, IS OFFERED.** Yaskawa assumes no liability for any personal injury, property damage, losses, or claims arising from misapplication of its products.

This manual is designed to ensure correct and suitable application of Variable E1000-Series Drives. Read this manual before attempting to install, operate, maintain, or inspect a drive and keep it in a safe, convenient location for future reference. Be sure you understand all precautions and safety information before attempting application.

## ◆ Applicable Documentation

The following manuals are available for E1000 series drives:

	<b>E1000 Series AC Drive Quick Start Guide</b> This guide is available only in Chinese. It is packaged together with the product. It contains basic information required to install and wire the drive, in addition to an overview of fault diagnostics, maintenance, and parameter settings. It is meant to get the drive ready for a trial run with the application and for basic operation.
	<b>E1000 Series AC Drive Technical Manual (this book)</b> This manual is included on the CD-ROM packaged with the product (YASKAWA AC Drive Manuals, TOMCC71060013), and is also available for download on our documentation website, <a href="http://www.Yaskawa.com.cn">http://www.Yaskawa.com.cn</a> . This manual provides detailed information on parameter settings, drive functions, and MEMOBUS/Modbus specifications. Use this manual to expand drive functionality and to take advantage of higher performance features.

## ◆ Symbols

**Note:** Indicates a supplement or precaution that does not cause drive damage.



**Indicates a term or definition used in this manual.**

## ◆ Terms and Abbreviations



- **Drive:** YASKAWA E1000 Series Drive
- **V/f:** V/f Control
- **OLV/PM:** Open Loop Vector Control for PM
- **PM motor:** Permanent Magnet Synchronous motor (an abbreviation for IPM motor or SPM motor)
- **IPM motor:** Interior Permanent Magnet Motor (such as Yaskawa's SSR1 Series)
- **SPM motor:** Surface mounted Permanent Magnet Motor (such as Yaskawa's SMRA Series motors)

## i.2 General Safety

### ◆ Supplemental Safety Information

#### General Precautions

- The diagrams in this manual may be indicated without covers or safety shields to show details. Restore covers or shields before operating the drive and run the drive according to the instructions described in this manual.
- Any illustrations, photographs, or examples used in this manual are provided as examples only and may not apply to all products to which this manual is applicable.
- The products and specifications described in this manual or the content and presentation of the manual may be changed without notice to improve the product and/or the manual.
- When ordering a new copy of the manual due to damage or loss, contact your Yaskawa representative or the nearest Yaskawa sales office and provide the manual number shown on the front cover.
- If nameplate becomes worn or damaged, order a replacement from your Yaskawa representative or the nearest Yaskawa sales office.

#### WARNING

Read and understand this manual before installing, operating or servicing this drive. The drive must be installed according to this manual and local codes.

The following conventions are used to indicate safety messages in this manual. Failure to heed these messages could result in serious or possibly even fatal injury or damage to the products or to related equipment and systems.

#### DANGER

Indicates a hazardous situation, which, if not avoided, will result in death or serious injury.

#### WARNING

Indicates a hazardous situation, which, if not avoided, could result in death or serious injury.

**WARNING!** will also be indicated by a bold key word embedded in the text followed by an italicized safety message.

#### CAUTION

Indicates a hazardous situation, which, if not avoided, could result in minor or moderate injury.

**CAUTION!** will also be indicated by a bold key word embedded in the text followed by an italicized safety message.

#### NOTICE

Indicates a property damage message.

**NOTICE:** will also be indicated by a bold key word embedded in the text followed by an italicized safety message.

### ◆ Safety Messages

#### DANGER

##### **Heed the safety messages in this manual.**

Failure to comply will result in death or serious injury.

The operating company is responsible for any injuries or equipment damage resulting from failure to heed the warnings in this manual.

#### **Electrical Shock Hazard**

##### **Do not connect or disconnect wiring while the power is on.**

Failure to comply will result in death or serious injury.

Before servicing, disconnect all power to the equipment. The internal capacitor remains charged even after the power supply is turned off. After shutting off the power, wait for at least the amount of time specified on the drive before touching any components.

#### WARNING

#### **Sudden Movement Hazard**

##### **System may start unexpectedly upon application of power, resulting in death or serious injury.**

Clear all personnel from the drive, motor and machine area before applying power. Secure covers, couplings, shaft keys and machine loads before applying power to the drive.

##### **When using DriveWorksEZ to create custom programming, the drive I/O terminal functions change from factory settings and the drive will not perform as outlined in this manual.**

Unpredictable equipment operation may result in death or serious injury.

Take special note of custom I/O programming in the drive before attempting to operate equipment.

#### **Electrical Shock Hazard**

##### **Do not attempt to modify or alter the drive in any way not explained in this manual.**

Failure to comply could result in death or serious injury.

Yaskawa is not responsible for any modification of the product made by the user. This product must not be modified.

##### **Do not allow unqualified personnel to use equipment.**

Failure to comply could result in death or serious injury.

Maintenance, inspection, and replacement of parts must be performed only by authorized personnel familiar with installation, adjustment and maintenance of AC drives.

##### **Do not remove covers or touch circuit boards while the power is on.**

Failure to comply could result in death or serious injury.

##### **Make sure the protective earthing conductor complies with technical standards and local safety regulations.**

Because the leakage current exceeds 3.5 mA in models CIMR-E□4A0414 and larger, IEC 61800-5-1 states that either the power supply must be automatically disconnected in case of discontinuity of the protective earthing conductor or a protective earthing conductor with a cross-section of at least 10 mm<sup>2</sup> (Cu) or 16 mm<sup>2</sup> (Al) must be used. Failure to comply may result in death or serious injury.

##### **Use appropriate equipment for electric leakage circuit breaker (ELCB).**

This drive can cause a residual current with a DC component in the protective earthing conductor. Where a residual current operated protective or monitoring device is used for protection in case of direct or indirect contact, always use an ELCB of type B according to IEC 60755.



**⚠ WARNING****Fire Hazard**

**Do not use an improper voltage source.**

Failure to comply could result in death or serious injury by fire.

Verify that the rated voltage of the drive matches the voltage of the incoming power supply before applying power.

**Crush Hazard**

**Do not use this drive in lifting applications.**

Failure to comply could result in death or serious injury from falling loads.

**⚠ CAUTION****Crush Hazard**

**Do not carry the drive by the front cover.**

Failure to comply may result in minor or moderate injury from the main body of the drive falling.

**NOTICE**

**Observe proper electrostatic discharge procedures (ESD) when handling the drive and circuit boards.**

Failure to comply may result in ESD damage to the drive circuitry.

**Do not perform a withstand voltage test on any part of the drive.**

Failure to comply could result in damage to the sensitive devices within the drive.

**Do not operate damaged equipment.**

Failure to comply could result in further damage to the equipment.

Do not connect or operate any equipment with visible damage or missing parts.

**Install adequate branch circuit short circuit protection per applicable codes.**

Failure to comply could result in damage to the drive.

The drive is suitable for circuits capable of delivering not more than 100,000 RMS symmetrical Amperes, 240 Vac maximum (200 V Class) and 480 Vac maximum (400 V Class).

**Do not expose the drive to halogen group disinfectants.**

Failure to comply may cause damage to the electrical components in the drive.

Do not pack the drive in wooden materials that have been fumigated or sterilized.

Do not sterilize the entire package after the product is packed.

### ◆ Application Notes

#### ■ Selection

##### Installing a Reactor

An AC or DC reactor can be used for the following:

- to suppress harmonic current.
- to smooth peak current that results from capacitor switching.
- when the power supply is above 600 kVA.
- when the drive is running from a power supply system with thyristor converters.

**Note:** A DC reactor is built in to the drive models 2A0110 to 2A0415 and 4A0058 to 4A1200.

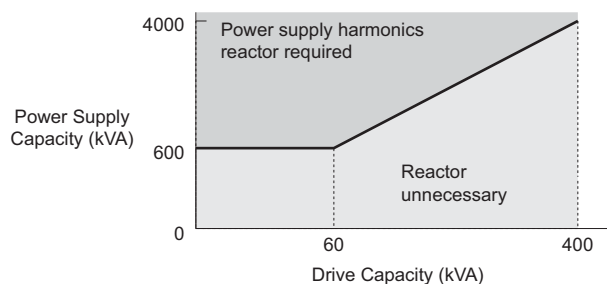


Figure i.1 Installing a Reactor

##### Drive Capacity

For specialized motors, make sure that the motor rated current is less than rated output current for the drive. When running more than one motor in parallel from a single drive, the capacity of the drive should be larger than 1.1 times of the total motor rated current.

##### Starting Torque

The overload rating for the drive determines the starting and accelerating characteristics of the motor. Expect lower torque than when running from line power. To get more starting torque, use a larger drive or increase both the motor and drive capacity.

##### Emergency Stop

When the drive faults out, the output is shut off. This, however, does not stop the motor immediately. Some type of mechanical brake may be needed if it is necessary to halt the motor faster than the Fast Stop function is able to.

##### Options

The +1, +2, and +3 terminals are used to connect optional devices. Connect only E1000-compatible devices.

#### ■ Installation

##### Enclosure Panels

Keep the drive in a clean environment by either selecting an area free of airborne dust, lint, and oil mist, or install the drive in an enclosure panel. Be sure to leave the required space between drives to provide for cooling, and that proper measures are taken so that the ambient temperature remains within allowable limits. Keep flammable materials away from the drive. If the drive must be used in an area where it is subjected to oil mist and excessive vibration, protective designs are available. Contact Yaskawa or your Yaskawa agent for details.

##### Installation Direction

The drive should be installed upright as specified in the manual. For more information on installation, [Refer to Mechanical Installation on page 44](#).

#### ■ Settings

##### Motor Code

If using OLV/PM designed for permanent magnet motors, make sure that the proper motor code has been set to parameter E5-01 before performing a trial run.

### Upper Limits

The drive is capable of running the motor up to 200 Hz. Due to the danger of accidentally operating at high speed, be sure to set the upper limit for the frequency. The default setting for the maximum output frequency is 200Hz.

### DC Injection Braking

Motor overheat can result if there is too much current used during DC Injection Braking, or if the time for DC Injection Braking is too long.

### Acceleration/Deceleration Times

Acceleration and deceleration times are affected by how much torque the motor generates, the load torque, and the inertia moment. Set a longer accel/decel time when Stall Prevention is enabled. The accel/decel times are lengthened for as long as the Stall Prevention function is operating. For faster acceleration and deceleration, install one of the dynamic braking options available or increase the capacity of the drive.

## ■ Compliance with Harmonic Suppression Guidelines

E1000 conforms to strict guidelines in Japan covering harmonic suppression for power conversion devices. Defined in JEM-TR201 and JEM-TR226 and published by the Japan Electrical Manufacturers' Association, these guidelines define the amount of harmonic current output acceptable for new installation. Instructions on calculation harmonic output are available at [www.e-mechatronics.com](http://www.e-mechatronics.com).

## ■ General Handling

### Wiring Check

Never connect the power supply lines to output terminals U/T1, V/T2, or W/T3. Doing so will destroy the drive. Be sure to perform a final check of all sequence wiring and other connections before turning the power on. Make sure there are no short circuits on the control terminals (+V, AC, etc.), as this could damage the drive.

### Selecting a Circuit Breaker or Leakage Circuit Breaker

Yaskawa recommends installing an Earth Leakage Circuit Breaker (ELCB) to the power supply side. The ELCB should be designed for use with an AC drive (e.g. Type B according to IEC 60755).

Select a MCCB (Molded Case Circuit Breaker) or ELCB with a rated current that is 1.5 to 2 times higher than the rated current of the drive in order to avoid nuisance trips caused by harmonics in the drive input current. Also refer to [Installing a Molded Case Circuit Breaker \(MCCB\) and Earth Leakage Circuit Breaker \(ELCB\) on page 341](#).

**NOTICE:** Prevent Equipment Damage. For models CIMR-E□4A0930 and 4A1200, make sure to install a fuse and an ELCB. Failure to comply may result in serious damage to the facilities in case the drive is defected. Refer to [Wiring Fuses for the CIMR-E□4A0930 and 4A1200 on page 346](#) for details.

### Magnetic Contactor Installation

Use a magnetic contactor (MC) to ensure that power to the drive can be completely shut off when necessary. The MC should be wired so that it opens when a fault output terminal is triggered.

Avoid switching a magnetic contactor on the power supply side more frequently than once every 30 minutes. Frequent switching can cause damage to the drive.

### Inspection and Maintenance

Capacitors in the drive take time to discharge even after the power has been shut off. After shutting off the power, wait for at least the amount of time specified on the drive before touching any components.

The heatsink can become quite hot during operation, and proper precautions should be taken to prevent burns. When replacing the cooling fan, shut off the power and wait at least 15 minutes to be sure that the heatsink has cooled down.

Even when the power has been shut off for a drive running a PM motor, voltage continues to be generated at the motor terminals while the motor coasts to stop. Take the precautions described below to prevent shock and injury:

- Applications where the machine can still rotate even though the drive has fully stopped should have a load switch installed to the output side of the drive. Yaskawa recommends manual load switches from the AICUT LB Series by AICHI Electric Works Co., Ltd.
- Do not allow an external force to rotate the motor beyond the maximum allowable speed, also when the drive has been shut off.

## i.2 General Safety

- Wait for at least the time specified on the warning label after opening the load switch on the output side before inspecting the drive or performing any maintenance.
- Do not open and close the load switch while the motor is running, as this can damage the drive.
- If the motor is coasting, make sure the power to the drive is turned on and the drive output has completely stopped before closing the load switch.

### Wiring

All wire ends should use ring terminals for UL/cUL compliance. Use only the tools recommended by the terminal manufacturer for crimping.

## ◆ Notes on Motor Operation

### ■ Using a Standard Motor

#### Low Speed Range

The cooling fan of a standard motor is usually designed to sufficiently cool the motor at the rated speed. As the self-cooling capability of such a motor reduces with the speed, applying full torque at low speed will possibly damage the motor. To prevent motor damage from overheat, reduce the load torque as the motor slows.

*Figure i.2* shows the allowable load characteristics for a Yaskawa standard motor. A motor designed specifically for operation with a drive should be used when 100% continuous torque is needed at low speeds.

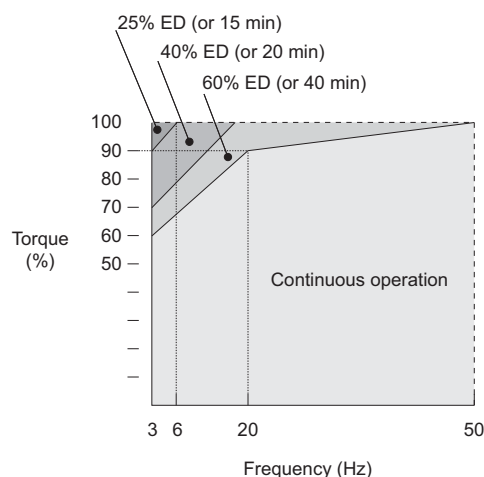


Figure i.2 Allowable Load Characteristics for a Yaskawa Motor

#### Insulation Tolerance

Consider voltage tolerance levels and insulation in applications with an input voltage of over 440 V or particularly long wiring distances. Contact Yaskawa or your Yaskawa agent for consultation.

#### High Speed Operation

Problems may occur with the motor bearings and dynamic balance of the machine when operating a motor beyond its rated speed. Contact the motor or machine manufacturer.

#### Torque Characteristics

Torque characteristics differ compared to operating the motor directly from line power. The user should have a full understanding of the load torque characteristics for the application.

#### Vibration and Shock

E1000 lets the user choose between high carrier PWM control and low carrier PWM. Selecting high carrier PWM can help reduce motor oscillation.

Take particular caution when using a variable speed drive for an application that is conventionally run from line power at a constant speed. If resonance occurs shock-absorbing rubber should be installed around the base of the motor and the Jump frequency selection should be enabled to prevent continuous operation in the resonant frequency range.

## Audible Noise

Noise created during run varies by the carrier frequency setting. When using a high carrier frequency, audible noise from the motor is comparable to the motor noise generated when running from line power. Operating above the rated r/min, however, can create unpleasant motor noise.

### ■ Using a Synchronous Motor

- Contact Yaskawa or your Yaskawa agent if you plan to use any other synchronous motor not endorsed by Yaskawa.
- A single drive is not capable of running multiple synchronous motors at the same time. Use a standard induction motor for such setups.
- At start, a synchronous motor may rotate slightly in the opposite direction of the Run command depending on parameter settings and rotor position.
- The amount of starting torque that can be generated differs by each control mode and by the type of motor being used. Set up the motor with the drive after verifying the starting torque, allowable load characteristics, impact load tolerance, and speed control range.

Contact Yaskawa or your Yaskawa agent if you plan to use a motor that does not fall within these specifications.

- Speed Search can be used to restart a coasting motor.
- In Open Loop Vector Control for PM motors, the allowable load inertia moment is approximately 50 times higher than the motor inertia moment or less. Contact Yaskawa or your Yaskawa agent concerning applications with a larger inertia moment.

## ◆ Applications with Specialized Motors

### ■ Applications with Specialized Motors

#### Multi-Pole Motor

Because the rated current will differ from a standard motor, be sure to check the maximum current when selecting a drive. Always stop the motor before switching between the number of motor poles. If a regen overvoltage fault occurs or if overcurrent protection is triggered, the motor will coast to stop.

#### Submersible Motor

Because motor rated current is greater than a standard motor, select the drive capacity accordingly. Be sure to use a large enough motor cable to avoid decreasing the maximum torque level on account of voltage drop caused by a long motor cable.

#### Explosion-Proof Motor

Both the motor and drive need to be tested together to be certified as explosion-proof. The drive is not designed for explosion proof areas.

Furthermore, if an encoder is attached to an explosion-proof motor make sure the encoder is explosion-proof too. Use an insulating signal converter for connecting the encoder signal lines to the drives speed feedback option card.

#### Geared Motor

To avoid gear damage when operating at low speeds or very high speeds, make sure that both the gear and lubricant are rated for the desired speed range. Consult with the manufacturer for applications that require operation outside the rated speed range of the motor or gear box.

#### Single-Phase Motor

Variable speed drives are not designed for operation with single phase motors. Using capacitors to start the motor causes excessive current to flow and can damage drive components. A split-phase start or a repulsion start can end up burning out the starter coils because the internal centrifugal switch is not activated. E1000 is for use with 3-phase motors only.

#### Motor with Brake

Caution should be taken when using a drive to operate a motor with a built-in holding brake. If the brake is connected to the output side of the drive, it may not release at start due to low voltage levels. A separate power supply should be installed for the motor brake. Motors with a built-in brake tend to generate a fair amount of noise when running at low speeds.

### ■ Notes on Power Transmission Parts (belts, chains, gear boxes, ...)

Installing a drive in a machine that was directly connected to the power supply allows to adjust the machine speed. Continuous operation above or below the rated speed can wear on lubrication material in gear boxes and other power transmission parts. In order to avoid machine damage make sure lubrication is sufficient within the whole speed range. Note that operation above the rated speed can increase the noise generated by the machine.

### ◆ Drive Label Warnings

Always heed the warning information listed in [Figure i.3](#) in the position shown in [Figure i.4](#).

**! WARNING**

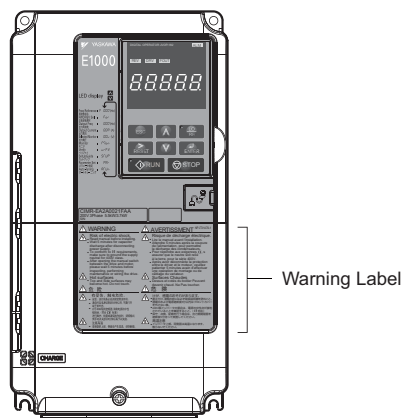
**⚡ Risk of electric shock.**

- Read manual before installing.
- Wait 5 minutes for capacitor discharge after disconnecting power supply.
- To conform to **CE** requirements, make sure to ground the supply neutral for 400V class.
- After opening the manual switch between the drive and motor, please wait 5 minutes before inspecting, performing maintenance or wiring the drive.

**🔥 Hot surfaces**

- Top and Side surfaces may become hot. Do not touch.

**Figure i.3 Warning Information**



**Figure i.4 Warning Information Position**

---

## ◆ Warranty Information

### ■ Warranty Period

This drive is warranted for 12 months from the date of delivery to the customer or 18 months from the date of shipment from the Yaskawa factory, whichever comes first.

### ■ Scope of Warranty

#### Inspections

Customers are responsible for periodic inspections of the drive. Upon request, a Yaskawa representative will inspect the drive for a fee. If the Yaskawa representative finds the drive to be defective due to Yaskawa workmanship or materials and the defect occurs during the warranty period, this inspection fee will be waived and the problem remedied free of charge.

#### Repairs

If a Yaskawa product is found to be defective due to Yaskawa workmanship or materials and the defect occurs during the warranty period, Yaskawa will provide a replacement, repair the defective product, and provide shipping to and from the site free of charge.

However, if the Yaskawa Authorized Service Center determines that the problem with the drive is not due to defective workmanship or materials, the customer will be responsible for the cost of any necessary repairs. Some problems that are outside the scope of this warranty are:

Problems due to improper maintenance or handling, carelessness, or other reasons where the customer is determined to be responsible.

Problems due to additions or modifications made to a Yaskawa product without Yaskawa's understanding.

Problems due to the use of a Yaskawa product under conditions that do not meet the recommended specifications.

Problems caused by natural disaster or fire.

After the free warranty period elapses.

Replenishment or replacement of consumables or expendables.

Defective products due to packaging or fumigation.

Malfunction or problems caused by program that has been made by customers using DriveWorksEZ.

Other problems not due to defects in Yaskawa workmanship or materials.

Warranty service is only applicable within the country where the product was purchased. However, after-sales service is available for customers outside the country where the product was purchased for a reasonable fee.

Contact your local Yaskawa representative for more information.

#### Exceptions

Any inconvenience to the customer or damage to non-Yaskawa products due to Yaskawa's defective products whether within or outside of the warranty period are NOT covered by warranty.

### ■ Restrictions

E1000 was not designed or manufactured for use in devices or systems that may directly affect or threaten human lives or health.

Customers who intend to use the product described in this manual for devices or systems relating to transportation, health care, space aviation, atomic power, electric power, or in underwater applications must first contact their Yaskawa representatives or the nearest Yaskawa sales office.

This product has been manufactured under strict quality-control guidelines. However, if this product is to be installed in any location where failure of this product could involve or result in a life-and-death situation or loss of human life or in a facility where failure may cause a serious accident or physical injury, safety devices must be installed to minimize the likelihood of any accident.





## Receiving

---

This chapter explains how to inspect the drive upon receipt, and gives an overview of the different enclosure types and components.

<b>1.1 SECTION SAFETY</b> .....	<b>26</b>
<b>1.2 GENERAL DESCRIPTION</b> .....	<b>27</b>
<b>1.3 MODEL NUMBER AND NAMEPLATE CHECK</b> .....	<b>29</b>
<b>1.4 DRIVE MODELS AND ENCLOSURE TYPES</b> .....	<b>31</b>
<b>1.5 COMPONENT NAMES</b> .....	<b>32</b>

## 1.1 Section Safety

### CAUTION

**Do not carry the drive by the front cover or the terminal cover.**

Failure to comply may cause the main body of the drive to fall, resulting in minor or moderate injury.

### NOTICE

**Observe proper electrostatic discharge procedures (ESD) when handling the drive and circuit boards.**

Failure to comply may result in ESD damage to the drive circuitry.

**A motor connected to a PWM drive may operate at a higher temperature than a utility-fed motor and the operating speed range may reduce motor cooling capacity.**

Ensure that the motor is suitable for drive duty and/or the motor service factor is adequate to accommodate the additional heating with the intended operating conditions.

## 1.2 General Description

### ◆ E1000 Model Selection

**Table 1.1** gives a reference for drive selection depending on the motor power.

**Note:** The models and capacities in shown here are based on standard settings and operation conditions. Derating is required for higher carrier frequencies and higher ambient temperatures.

**Table 1.1 E1000 Models**

Motor Power (kW)	Three-Phase 200 V Class		Three-Phase 400 V Class	
	Model CIMR-E□	Rated Output Current (A)	Model CIMR-E□	Rated Output Current (A)
0.75	2A0004	3.5	4A0002	2.1
1.1	2A0006	6	–	–
1.5	2A0008	8	4A0004	4.1
2.2	2A0010	9.6	4A0005	5.4
3.0	2A0012	12	4A0007	6.9
3.7	2A0018	17.5	4A0009	8.8
5.5	2A0021	21	4A0011	11.1
7.5	2A0030	30	4A0018	17.5
11	2A0040	40	4A0023	23
15	2A0056	56	4A0031	31
18.5	2A0069	69	4A0038	38
22	2A0081	81	4A0044	44
30	2A0110	110	4A0058	58
37	2A0138	138	4A0072	72
45	2A0169	169	4A0088	88
55	2A0211	211	4A0103	103
75	2A0250	250	4A0139	139
90	2A0312	312	4A0165	165
110	2A0360	360	4A0208	208
	2A0415	415	–	–
132	–	–	4A0250	250
160	–	–	4A0296	296
185	–	–	4A0362	362
220	–	–	4A0414	414
250	–	–	4A0515	515
355	–	–	4A0675	675
500	–	–	4A0930	930
630	–	–	4A1200	1200

**Note:** Current derating is required when setting the carrier frequency higher. *Refer to Carrier Frequency Derating on page 354* for details.

## 1.2 General Description

### ◆ Control Mode Selection

Table 1.2 gives an overview of the E1000 control modes and their various features.

**Table 1.2 Control Modes and their Features**

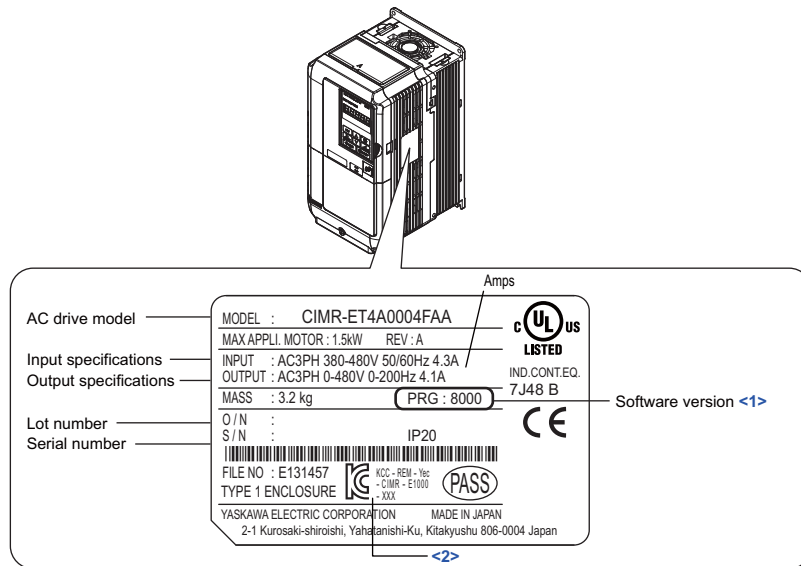
Motor Type		Induction Motors	Permanent Magnet Motors	Comments
Control Mode		V/f	OLV/PM	–
Parameter Setting		A1-02 = 0	A1-02 = 5	Default Setting is V/f control.
Basic Description		V/f control	Open Loop Vector control for PM motors	–
Type of Applications	Multi Motor	YES	N/A	–
	Motor data unknown	YES	N/A	–
	High Speed Accuracy	N/A	YES	–
Control Characteristics	Speed Control Range	1:40	1:20	May fluctuate with characteristics and motor temperature.
	Speed Accuracy	±2 to 3%	±0.2%	Speed deviation when operating at constant speed. May fluctuate with characteristics and motor temperature.
	Speed Response	3 Hz (approx.)	10 Hz	Max. frequency of a speed reference signal that the drive can follow. May fluctuate with characteristics and motor temperature.
	Starting Torque	150% at 3 Hz	100% at 5% speed	May fluctuate with characteristics and motor temperature. Performance may differ by capacity.
Application-Specific	Auto-Tuning	<ul style="list-style-type: none"> <li>• Energy Saving Tuning</li> <li>• Line-to-line resistance</li> </ul>	<ul style="list-style-type: none"> <li>• Stationary</li> <li>• Line-to-line resistance</li> </ul>	Automatically adjusts parameter settings that concern electrical characteristics of the motor.
	Speed Search	YES	YES	Bi-directional speed detection of a coasting motor to restart it without stopping.
	Energy-Saving Control	YES	N/A	Saves energy by always operating the motor at its maximum efficiency.
	High Slip Braking	YES	N/A	Increases motor loss to allow for faster deceleration than normal without the use of dynamic braking options. The effectiveness may vary based on motor characteristics.
	Kinetic Energy Buffering	YES	YES	Decelerates the drive to allow it to ride through a momentary power loss and continue operation.
	Overexcitation Deceleration	YES	N/A	Provides fast deceleration without using dynamic braking options.
	Overvoltage Suppression	YES	YES	Prevents overvoltage by increasing speed during regeneration. Never use this function with hoist or crane applications.

# 1.3 Model Number and Nameplate Check

Please perform the following tasks after receiving the drive:

- Inspect the drive for damage.  
If the drive appears damaged upon receipt, contact the shipper immediately.
- Verify receipt of the correct model by checking the information on the nameplate.
- If you have received the wrong model or the drive does not function properly, contact your supplier.

## ◆ Nameplate



<1> Drive models CIMR-E□4A0930 and 4A1200 use software version 380□. The availability of certain functions on these models differs from models CIMR-E□2A0004 to 2A0415 and 4A0002 to 4A0675, which use software version 800□.

Refer to [Parameter Groups on page 359](#) for details

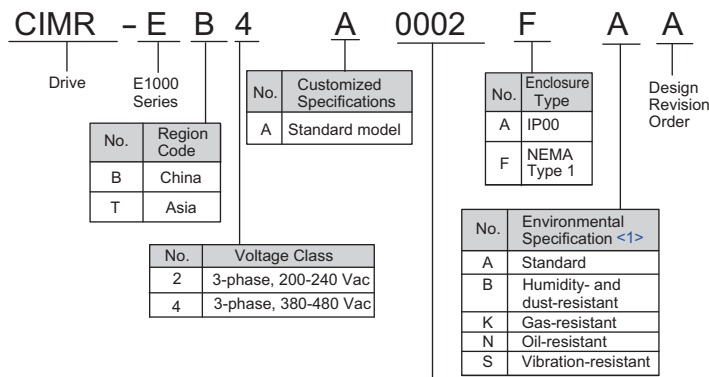
<2> Drive model CIMR-ET □□□□ that bears the KCC mark conforms to Korean Radio Waves Act and is designated for use in Asia (Region code: T).

Refer to [Model Number on page 29](#) for details.

☞마크가 부착되어 있는 제품은 한국 전파법에 적합한 아시아향 기종 ( 형식 : CIMR-ET□□□□ ) 입니다 .

Figure 1.1 Nameplate Information

## ◆ Model Number



Refer to [Table 1.3](#) and [Table 1.4](#).

<1> Drives with these specifications do not guarantee complete protection for the environmental conditions indicated.

Receiving

1

## 1.3 Model Number and Nameplate Check

### ■ Three-Phase 200 V

Table 1.3 Model Number and Specifications (200 V)

No.	Max. Motor Capacity kW	Rated Output Current A
0004	0.75	3.5
0006	1.1	6.0
0008	1.5	8.0
0010	2.2	9.6
0012	3.0	12
0018	3.7	17.5
0021	5.5	21
0030	7.5	30
0040	11	40
0056	15	56
0069	18.5	69
0081	22	81
0110	30	110
0138	37	138
0169	45	169
0211	55	211
0250	75	250
0312	90	312
0360	110	360
0415	110	415

### ■ Three-Phase 400 V

Table 1.4 Model Number and Specifications (400 V)

No.	Max. Motor Capacity kW	Rated Output Current A
0002	0.75	2.1
0004	1.5	4.1
0005	2.2	5.4
0007	3.0	6.9
0009	3.7	8.8
0011	5.5	11.1
0018	7.5	17.5
0023	11	23
0031	15	31
0038	18.5	38
0044	22	44
0058	30	58
0072	37	72
0088	45	88
0103	55	103
0139	75	139
0165	90	165
0208	110	208
0250	132	250
0296	160	296
0362	185	362
0414	220	414
0515	250	515
0675	355	675
0930	500	930
1200	630	1200

**Note:** Refer to *Drive Models and Enclosure Types on page 31* for differences regarding enclosure protection types and component descriptions.

## 1.4 Drive Models and Enclosure Types

Two types of enclosures are offered for E1000 drives.

- IP00 enclosure models are designed for installation in an enclosure panel that serves to protect personnel from injury caused by accidentally touching live parts.
- IP20/NEMA Type 1 enclosure models mount to an indoor wall or in an enclosure panel.

*Table 1.5* describes drive enclosures and models.

**Table 1.5 Drive Models and Enclosure Types**

Voltage Class	Enclosure Type	
	IP20/NEMA Type 1 Enclosure CIMR-E□	IP00 Enclosure CIMR-E□
Three-Phase 200 V Class	2A0004F	<1>
	2A0006F	<1>
	2A0008F	<1>
	2A0010F	<1>
	2A0012F	<1>
	2A0018F	<1>
	2A0021F	<1>
	2A0030F	<1>
	2A0040F	<1>
	2A0056F	<1>
	2A0069F	<1>
	2A0081F	<1>
	2A0110F <2>	2A0110A
	2A0138F <2>	2A0138A
	2A0169F <2>	2A0169A
	2A0211F <2>	2A0211A
	2A0250F <2>	2A0250A
2A0312F <2>	2A0312A	
2A0360F <2>	2A0360A	
-	2A0415A	
Three-Phase 400 V Class	4A0002F	<1>
	4A0004F	<1>
	4A0005F	<1>
	4A0007F	<1>
	4A0009F	<1>
	4A0011F	<1>
	4A0018F	<1>
	4A0023F	<1>
	4A0031F	<1>
	4A0038F	<1>
	4A0044F	<1>
	4A0058F <2>	4A0058A
	4A0072F <2>	4A0072A
	4A0088F <2>	4A0088A
	4A0103F <2>	4A0103A
	4A0139F <2>	4A0139A
	4A0165F <2>	4A0165A
	4A0208F <2>	4A0208A
	4A0250F <2>	4A0250A
	4A0296F <2>	4A0296A
4A0362F <2>	4A0362A	
-	4A0414A	
-	4A0515A	
-	4A0675A	
-	4A0930A	
-	4A1200A	

<1> Removing the top protective cover from a IP20/NEMA Type 1 enclosure drive voids NEMA Type 1 protection but still keeps IP20 conformity.  
 <2> Special order required. Contact your Yaskawa sales representative.

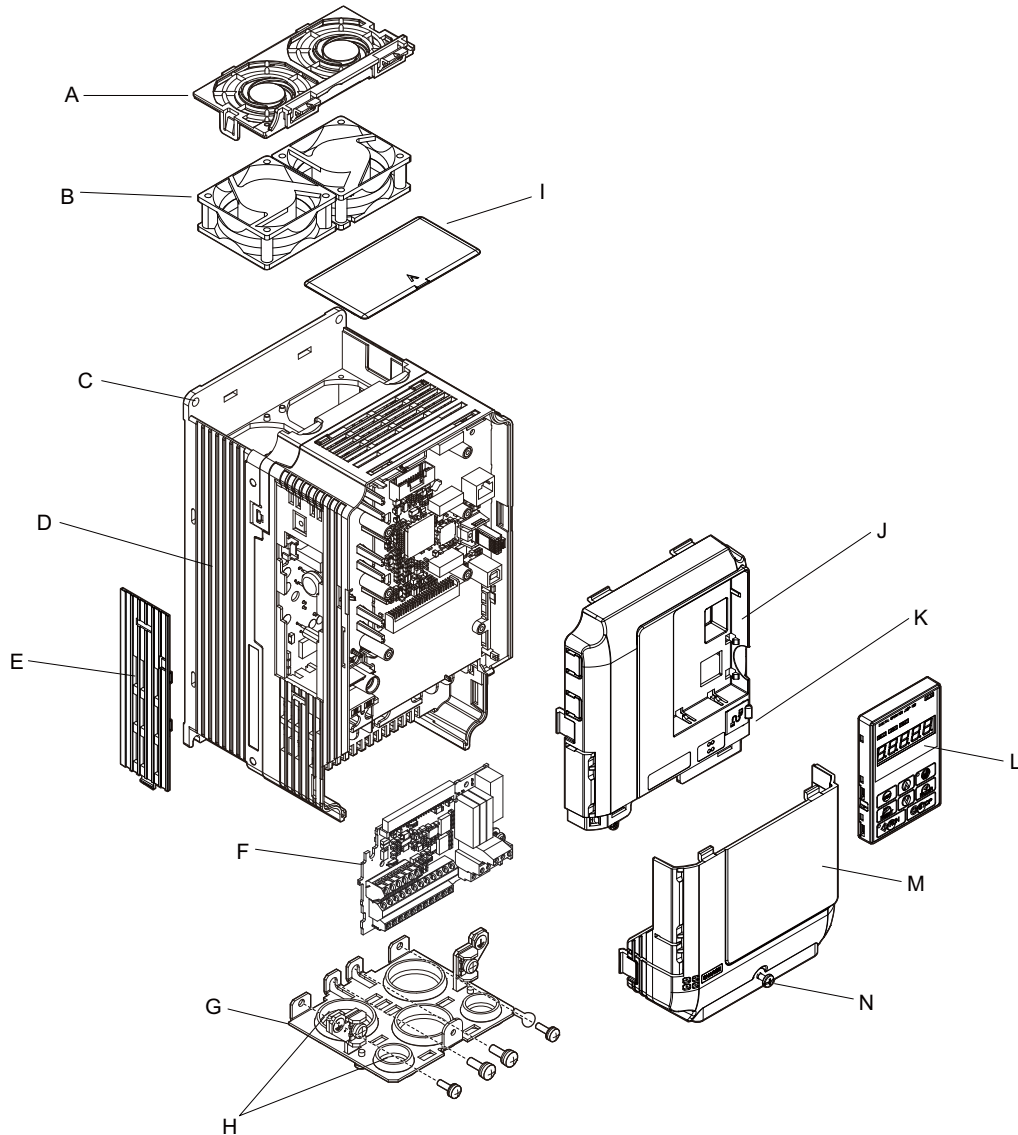
## 1.5 Component Names

This section gives an overview of the drive components described in this manual.

- Note:** 1. See [Using the Digital Operator on page 97](#) for a description of the operator keypad.  
 2. The drive may have no cooling fans or only one cooling fan depending on the model.

### ◆ IP20/NEMA Type 1 Enclosure

- Three-Phase AC200 V CIMR-E□2A0004F to 0081F
- Three-Phase AC400 V CIMR-E□4A0002F to 0044F



- |  |                                 |
|--|---------------------------------|
| <b>A</b> – Fan cover <1>                                 | <b>H</b> – Rubber bushing       |
| <b>B</b> – Cooling fan <1>                               | <b>I</b> – Top protective cover |
| <b>C</b> – Mounting hole                                 | <b>J</b> – Front cover          |
| <b>D</b> – Heatsink                                      | <b>K</b> – USB port (type-B)    |
| <b>E</b> – Optional 24 V DC power supply connector cover | <b>L</b> – Digital Operator     |
| <b>F</b> – Terminal board                                | <b>M</b> – Terminal cover       |
| <b>G</b> – Bottom cover                                  | <b>N</b> – Terminal cover screw |

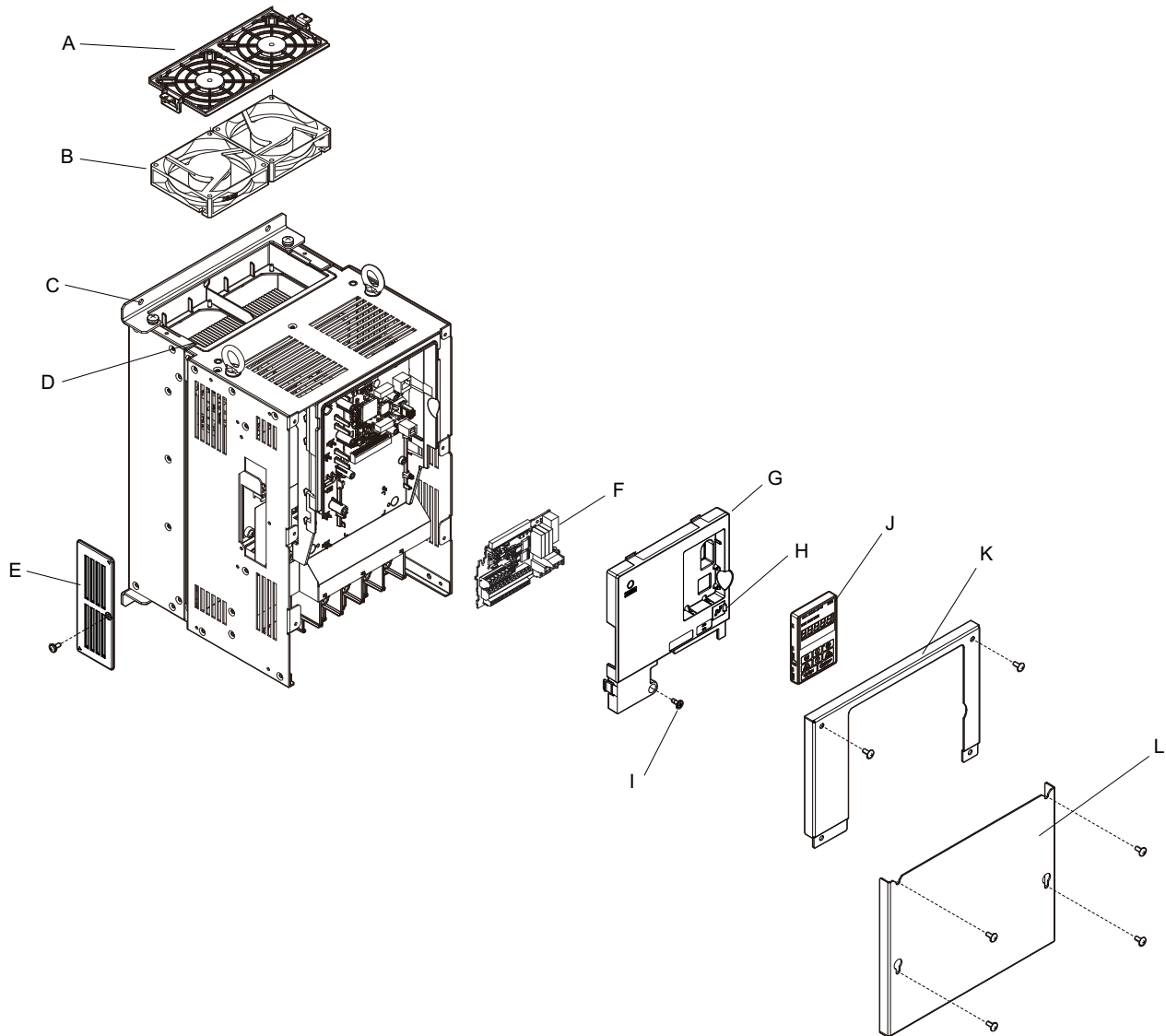
<1> The following drive models have a single cooling fan: CIMR-E□2A0018F and 0021F, CIMR-E□4A0007F through 0011F.  
 Drives CIMR-E□2A0004F through 0012F and CIMR-E□4A0002F through 0005F do not have a cooling fan or a cooling fan cover.

**Figure 1.2 Exploded View of IP20/NEMA Type 1 Enclosure Components (CIMR-E□2A0030F)**



## ◆ IP00 Enclosure

- Three-Phase AC200 V CIMR-E□2A0110A, 0138A
- Three-Phase AC400 V CIMR-E□4A0058A to 0103A

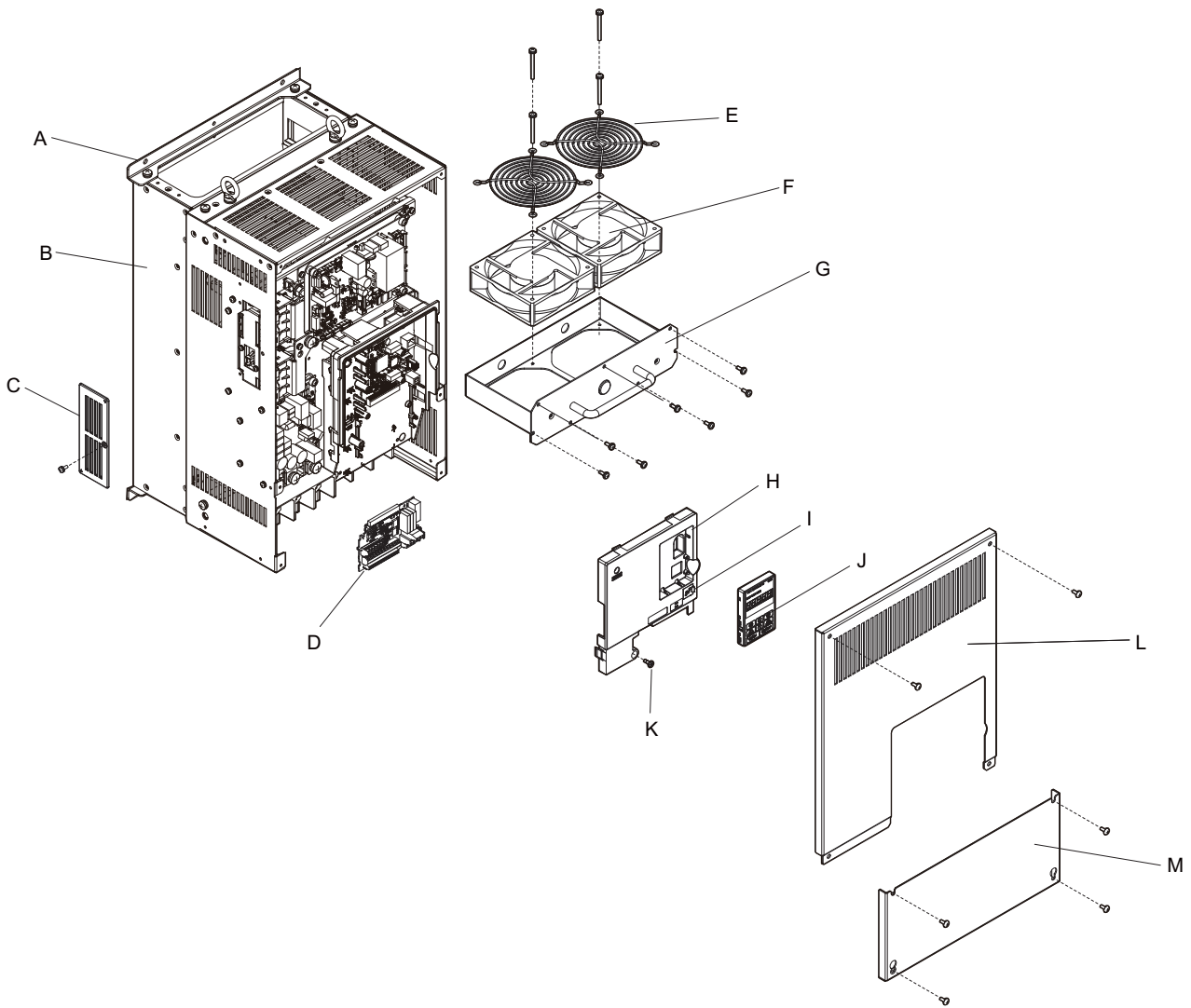


- |  |                       |
|--|-----------------------|
| A – Fan cover  | G – Front cover       |
| B – Cooling fan                                      | H – USB port (type-B) |
| C – Mounting hole                                    | I – Front cover screw |
| D – Heatsink   | J – Digital operator  |
| E – Optional 24 V DC power<br>supply connector cover | K – Drive Cover       |
| F – Terminal board                                   | L – Terminal cover    |

Figure 1.3 Exploded View of IP00 Enclosure Components (CIMR-E□2A0110A)

## 1.5 Component Names

### ■ Three-Phase AC200 V CIMR-E□2A0169A to 0312A Three-Phase AC400 V CIMR-E□4A0139A to 0208A

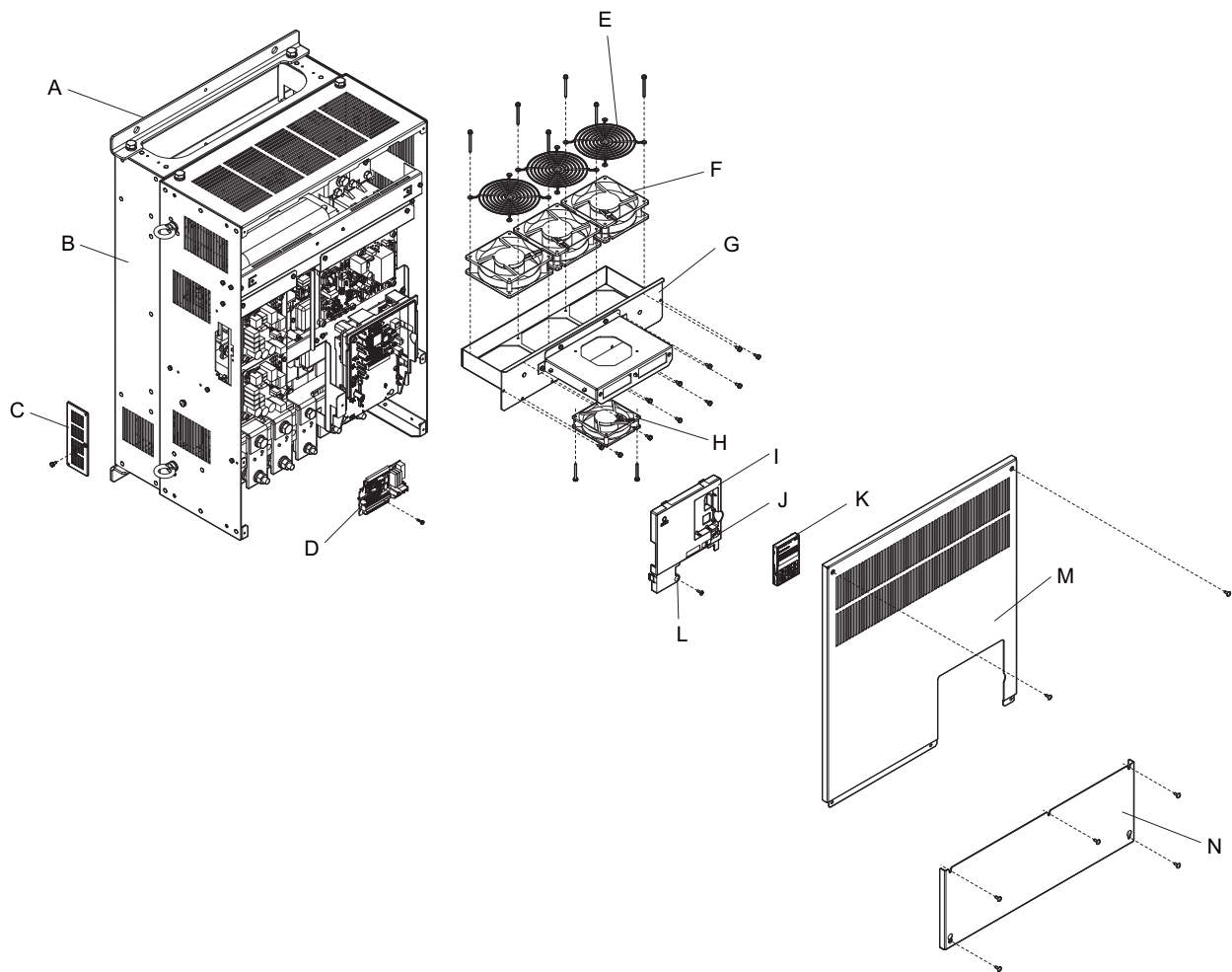


A – Mounting hole  
B – Heatsink  
C – Optional 24 V DC power  
supply connector cover  
D – Terminal board  
E – Fan guard  
F – Cooling fan  
G – Fan unit case

H – Front cover  
I – USB port (type-B)  
J – Digital operator  
K – Front cover screw  
L – Drive cover  
M – Terminal cover

Figure 1.4 Exploded view of IP00 Enclosure Type Components (CIMR-E□4A0165A)

■ Three-Phase AC200 V CIMR-E□2A0360A, 0415A  
 Three-Phase AC400 V CIMR-E□4A0250A to 0362A



- |  |                                |
|--|--------------------------------|
| <b>A</b> – Mounting hole                                 | <b>H</b> – Circulation fan <1> |
| <b>B</b> – Heatsink                                      | <b>I</b> – Front cover         |
| <b>C</b> – Optional 24 V DC power supply connector cover | <b>J</b> – USB port (type-B)   |
| <b>D</b> – Terminal board                                | <b>K</b> – Digital operator    |
| <b>E</b> – Fan guard                                     | <b>L</b> – Front cover screw   |
| <b>F</b> – Cooling fan                                   | <b>M</b> – Drive cover         |
| <b>G</b> – Fan unit case                                 | <b>N</b> – Terminal cover      |

<1> The following drive models come with a built-in circulation fan.  
 CIMR-E□2A0360, 2A0415  
 CIMR-E□4A0362

Figure 1.5 Exploded view of IP00 Enclosure Type Components (CIMR-E□4A0362A)

■ Three-Phase AC400 V CIMR-E□4A0414A

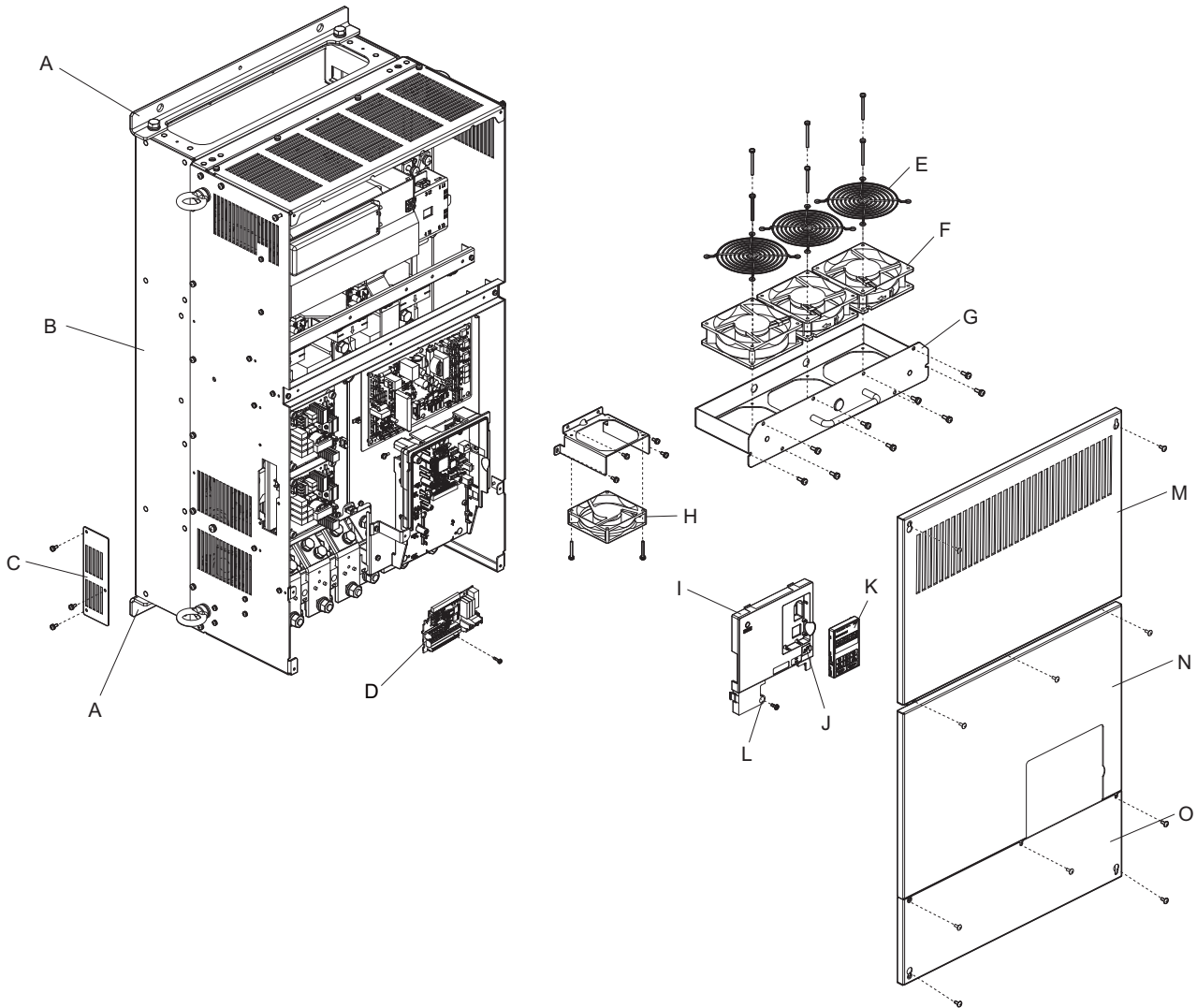
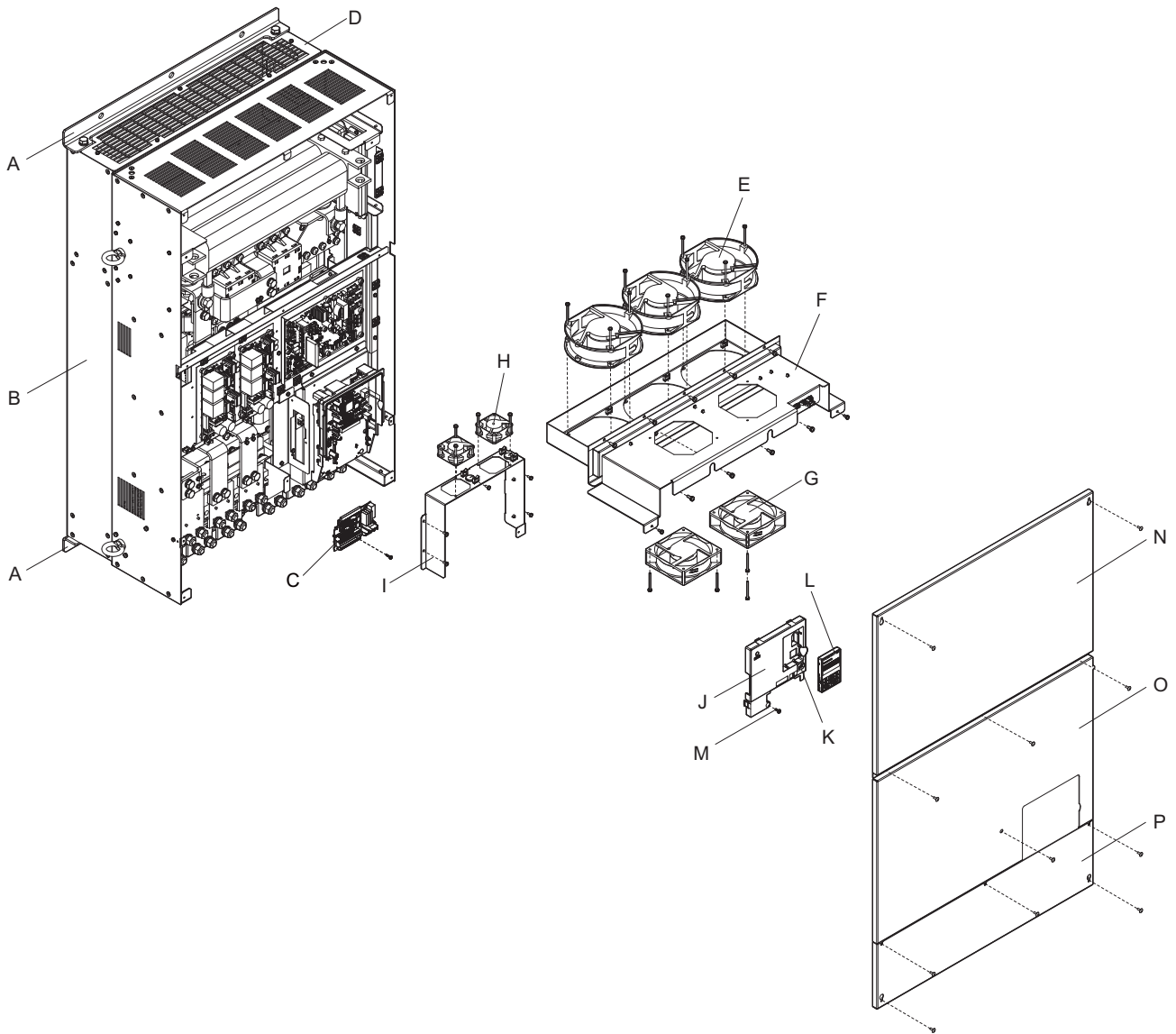


Figure 1.6 Exploded view of IP00 Enclosure Type Components (CIMR-E□4A0414A)

### ■ Three-Phase AC400 V CIMR-E□4A0515A, 0675A



**A** – Mounting hole

**B** – Heatsink

**C** – Terminal board

**D** – Fan guard

**E** – Cooling fan

**F** – Fan unit case

**G** – Circulation fan

**H** – Circuitboard cooling fan

**I** – Circuitboard cooling fan unit case

**J** – Front cover

**K** – USB port (type-B)

**L** – Digital operator

**M** – Front cover screw

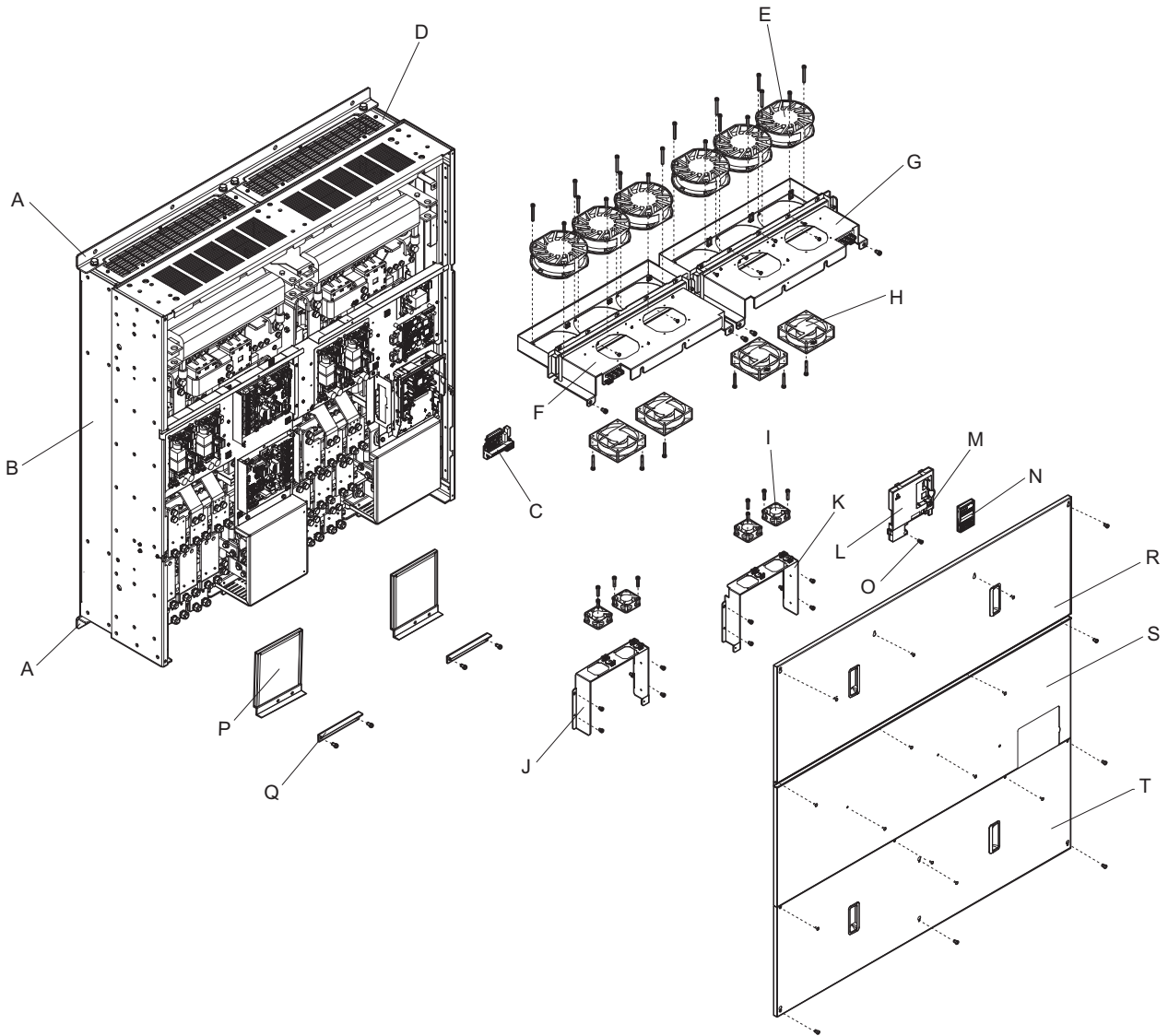
**N** – Drive cover 1

**O** – Drive cover 2

**P** – Terminal cover

Figure 1.7 Exploded view of IP00 Enclosure Type Components (CIMR-E□4A0675A)

## ■ Three-Phase AC400 V CIMR-E□4A0930A,1200A



**A – Mounting hole**

**B – Heatsink**

**C – Terminal board**

**D – Fan guard**

**E – Cooling fan**

**F – Fan unit case (L)**

**G – Fan unit case (R)**

**H – Circulation fan**

**I – Circuitboard cooling fan**

**J – Circuitboard cooling fan unit case (L)**

**K – Circuitboard cooling fan unit case (R)**

**L – Front cover**

**M – USB port (type-B)**

**N – Digital operator**

**O – Front cover screw**

**P – Filter case**

**Q – Blind cover**

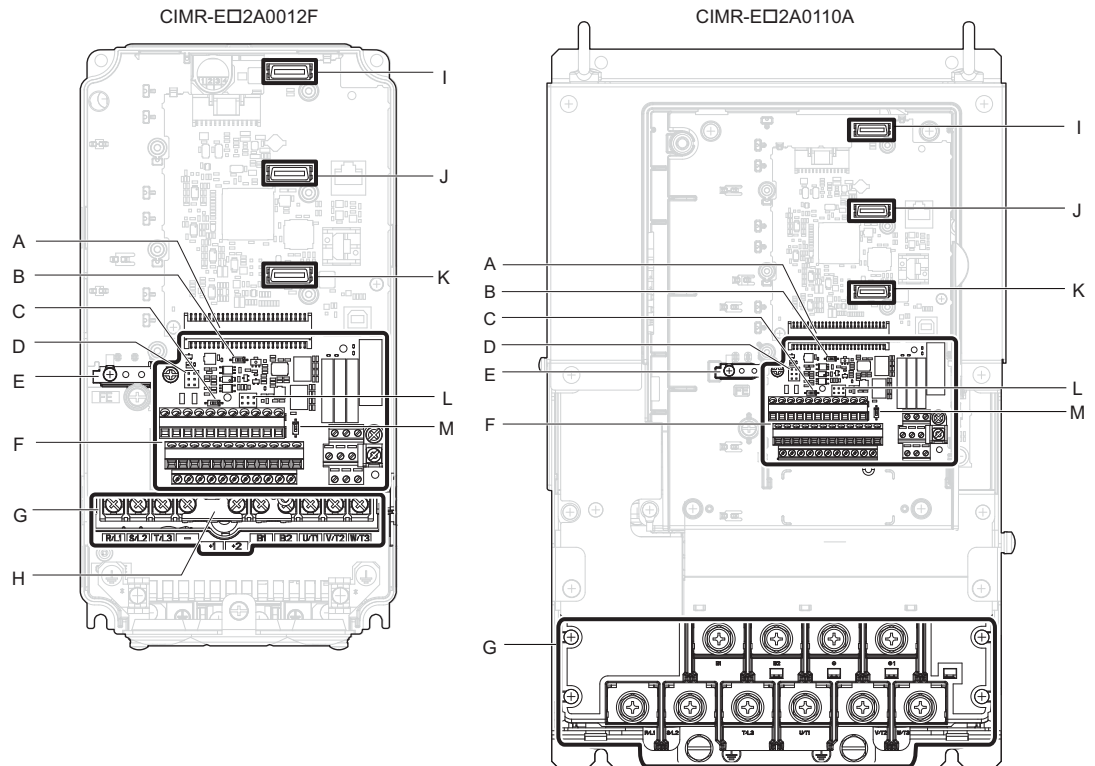
**R – Drive cover 1**

**S – Drive cover 2**

**T – Terminal cover**

**Figure 1.8 Exploded view of IP00 Enclosure Type Components (CIMR-E□4A0930A)**

## ◆ Front Views



A – Terminal board connector

B – DIP switch S1 (*Refer to Terminal A2 Input Signal Selection on page 88*)

C – DIP switch S2 (*Refer to MEMOBUS/ Modbus Termination on page 90*)

D – Jumper S3 (*refer to Sinking/Sourcing Mode Selection for Hardwire Baseblock Inputs on page 85*)

E – Ground terminal

F – Terminal board (*Refer to Control Circuit Wiring on page 79*)

G – Main circuit terminal (*Refer to Wiring the Main Circuit Terminal on page 78*)

H – Top protective cover to prevent miswiring

I – Option card connector (CN5-C)

J – Option card connector (CN5-B)

K – Option card connector (CN5-A)

L – Jumper S5 (*Refer to Terminal AM/FM Signal Selection on page 87*)

M – DIP Switch S4 (*Refer to Terminal A3 Analog/PTC Input Selection on page 87*)

Figure 1.9 Front View of Drives





## Mechanical Installation

---

This chapter explains how to properly mount and install the drive.

<b>2.1 SECTION SAFETY</b> .....	<b>42</b>
<b>2.2 MECHANICAL INSTALLATION</b> .....	<b>44</b>

## 2.1 Section Safety

### WARNING

#### Fire Hazard

**Provide sufficient cooling when installing the drive inside an enclosed panel or cabinet.**

Failure to comply could result in overheating and fire.

When multiple drives are placed inside the same enclosure panel, install proper cooling to ensure air entering the enclosure does not exceed 40°C.

#### Crush Hazard

**If using a crane or a lifter to transport the drive, make sure that only qualified personnel are allowed operating.**

Incorrect operation may cause the drive to suddenly drop, resulting in serious injury.

**Only allow qualified personnel to operate a crane or hoist to transport the drive.**

Failure to comply could result in death or serious injury from falling equipment.

### CAUTION

#### Crush Hazard

**Do not carry the drive by the front cover or the terminal cover.**

Failure to comply may result in minor or moderate injury from the main body of the drive falling.

### NOTICE

#### Equipment Hazard

**Prevent foreign matter such as metal shavings or wire clippings from falling into the drive during drive installation and project construction.**

Failure to comply could result in damage to the drive.

Place a temporary cover over the top during installation. Be sure to remove the temporary cover before start-up, as the cover will reduce ventilation and cause the unit to overheat.

**Observe proper electrostatic discharge (ESD) procedures when handling the drive.**

Failure to comply could result in ESD damage to the drive circuitry.

**Operating the motor in the low-speed range diminishes the cooling effects, increases motor temperature, and may lead to motor damage by overheating.**

Reduce the motor torque in the low-speed range whenever using a standard blower cooled motor. If 100% torque is required continuously at low speed, consider using a special drive or vector-control motor. Select a motor that is compatible with the required load torque and operating speed range.

**The speed range for continuous operation differs according to the lubrication method and motor manufacturer.**

If the motor is to be operated at a speed higher than the rated speed, consult with the manufacturer.

Continuously operating an oil-lubricated motor in the low-speed range may result in burning.

**When the input voltage is 440 V or higher or the wiring distance is greater than 100 meters, pay special attention to the motor insulation voltage or use a drive-rated motor with reinforced insulation.**

Failure to comply could lead to motor winding failure.

**Motor vibration may increase when operating a machine in variable-speed mode, if that machine previously operated at a constant speed.**

Install vibration-proof rubber on the motor base or use the frequency jump function to skip a frequency resonating the machine.

**The motor may require more acceleration torque with drive operation than with a commercial power supply.**

Set a proper V/f pattern by checking the load torque characteristics of the machine to be used with the motor.

**NOTICE**

**The rated input current of submersible motors is higher than the rated input current of standard motors.**

Select an appropriate drive according to its rated output current. When the distance between the motor and drive is long, use a cable thick enough to connect the motor to the drive to prevent motor torque reduction.

**The current rating differs for a motor with variable pole pitches differs from a standard motor.**

Check the maximum current of the motor before selecting the drive capacity. Only switch motor poles when the motor is stopped. Switching between motor during run will trigger overcurrent protection circuitry or result in overvoltage from regeneration, and the motor will simply coast to stop.

**When using an explosion-proof motor, it must be subject to an explosion-proof test in conjunction with the drive.**

This is also applicable when an existing explosion-proof motor is to be operated with the drive. Since the drive itself is not explosion-proof, always install it in a safe place.

**Never lift the drive up while the cover is removed.**

This can damage the terminal board and other components.

## 2.2 Mechanical Installation

This section outlines specifications, procedures, and the environment for proper mechanical installation of the drive.

### ◆ Installation Environment

To help prolong the optimum performance life of the drive, install the drive in an environment matching the specifications below.

**Table 2.1 Installation Environment**

Environment	Conditions
Installation Area	Indoors
Ambient Temperature	-10°C to +40°C (IP20/NEMA Type 1 enclosure) -10°C to +50°C (IP00 enclosure) Drive reliability improves in environments without wide temperature fluctuations. When using the drive in an enclosure panel, install a cooling fan or air conditioner in the area to ensure that the air temperature inside the enclosure does not exceed the specified levels. Do not allow ice to develop on the drive.
Humidity	95% RH or less and free of condensation
Storage Temperature	-20 to +60°C
Surrounding Area	Install the drive in an area free from: <ul style="list-style-type: none"> <li>• oil mist and dust</li> <li>• metal shavings, oil, water or other foreign materials</li> <li>• radioactive materials</li> <li>• combustible materials (e.g., wood)</li> <li>• harmful gases and liquids</li> <li>• excessive vibration</li> <li>• chlorides</li> <li>• direct sunlight</li> </ul>
Altitude	1000 m, up to 3000 m with derating (for details, refer to <a href="#">Altitude Derating on page 356</a> )
Vibration	10 to 20 Hz at 9.8 m/s <sup>2</sup> <1> 20 to 55 Hz at 5.9 m/s <sup>2</sup> (Models CIMR-E□2A0004 to 2A0211 and 4A0002 to 4A0165) or, 2.0 m/s <sup>2</sup> (Models CIMR-E□2A0250 to 2A0415 and 4A0208 to 4A1200)
Orientation	Install the drive vertically to maintain maximum cooling effects.

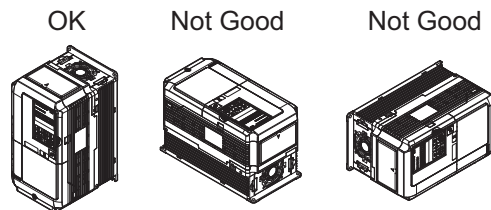
<1> Models CIMR-E□4A0930 and 4A1200 are rated at 5.9 m/s<sup>2</sup>.

**NOTICE:** Avoid placing drive peripheral devices, transformers, or other electronics near the drive as the noise created can lead to erroneous operation. If such devices must be used in close proximity to the drive, take proper steps to shield the drive from noise.

**NOTICE:** Prevent foreign matter such as metal shavings and wire clippings from falling into the drive during installation. Failure to comply could result in damage to the drive. Place a temporary cover over the top of the drive during installation. Remove the temporary cover before startup, as the cover will reduce ventilation and cause the drive to overheat.

### ◆ Installation Orientation and Spacing

Install the drive upright as illustrated in [Figure 2.1](#) to maintain proper cooling.



**Figure 2.1 Correct Installation Orientation**

### Single Drive Installation

Figure 2.2 shows the installation distance required to maintain sufficient space for airflow and wiring.

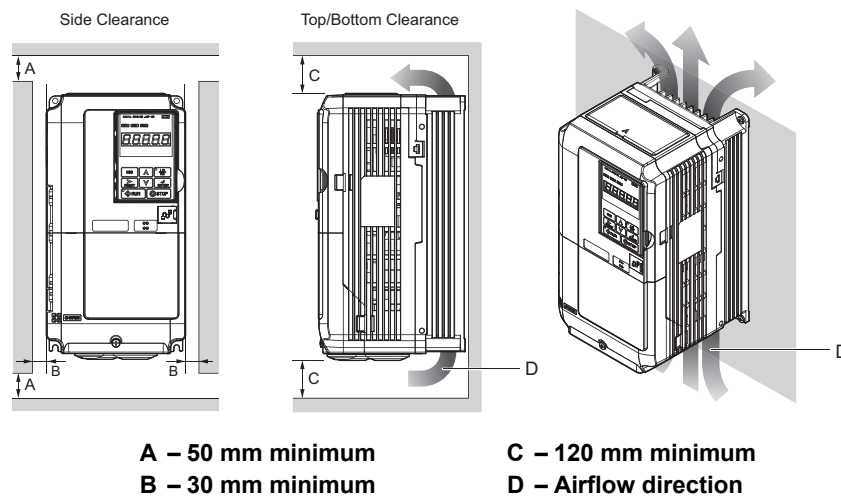


Figure 2.2 Correct Installation Spacing

**Note:** IP20/NEMA Type 1 enclosure and IP00 enclosure models require the same amount of space above and below the drive for installation.

### Multiple Drive Installation (Side-by-Side Installation)

Models CIMR-E□2A0004 through 0081 and 4A0002 through 0044 can take advantage of Side-by-Side installation.

When installing multiple drives into the same enclosure panel, mount the drives according to Figure 2.2.

When mounting drives with the minimum clearance of 2 mm according to Figure 2.3, derating must be considered and parameter L8-35 must be set to 1. Refer to Temperature Derating on page 355.

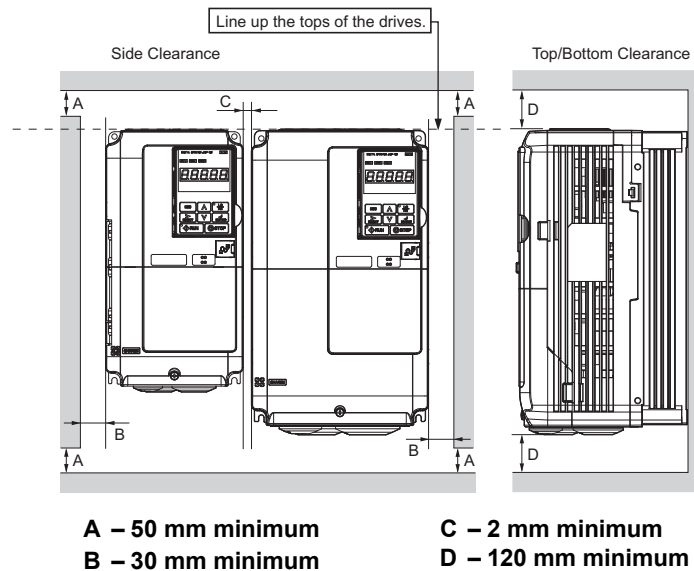


Figure 2.3 Space Between Drives (Side-by-Side Mounting)

**Note:** When installing drives of different heights in the same enclosure panel, the tops of the drives should line up. Leave space between the top and bottom of stacked drives for easy cooling fan replacement if required.

## 2.2 Mechanical Installation

When drives with IP20/NEMA Type 1 enclosures are mounted side by side, the top protective covers of all drives must be removed as shown in [Figure 2.4](#). Refer to [Top Protective Cover on page 71](#) to remove and reattach the top protective cover.

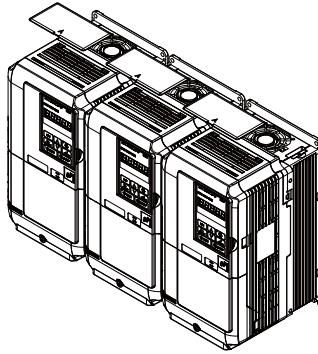


Figure 2.4 IP20/NEMA Type 1 Side-by-Side Mounting in Enclosure

### ◆ Instructions on Installation of Models CIMR-E□4A0930 and 4A1200

Read the following precautions and instructions before installing the largest-capacity models, 4A0930 and 4A1200.

**WARNING!** Be sure to observe the following instructions and precautions. Failure to comply could result in minor or moderate injury and damage to the drive from falling equipment.

- Vertical suspension of the drive should be used only for temporarily lifting the drive for installation in the enclosure panel. Do not vertically suspend for transportation of the drive.
- Before vertical suspension, make sure that the drive front cover, terminal blocks and other drive components are securely fixed with screws.
- Do not subject the drive to vibration or impact greater than  $1.96 \text{ m/s}^2$  (0.2 G) while it is suspended by the wires.
- Do not overturn the drive.
- Do not leave the drive for a long time while it is suspended by the wires

### ■ Procedure for Vertical Wire Suspension of the Drive

- Use the wire of a length that ensures a 50 degree or wider suspending angle, as illustrated in [Figure 2.6](#). The maximum allowable load of the eye bolts for suspension cannot be guaranteed when the drive is suspended with the wires at an angle less than 50 degrees.
- When lifting the drive with a crane after wires are passed to hold it, make sure to follow the procedure described below.
  1. Remove the four eye bolts from the drive side panels, and fix them securely on the top panel (See [Figure 2.5](#)).

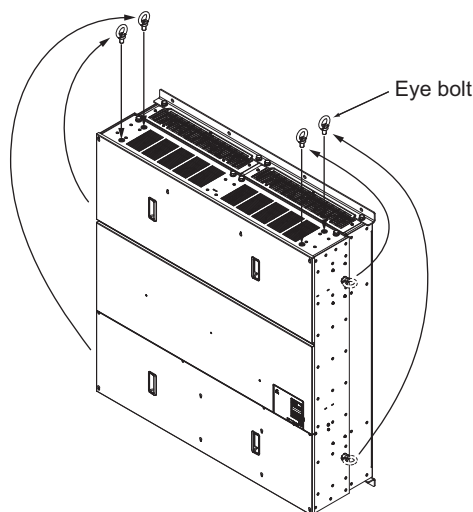


Figure 2.5 Attaching Eye Bolts on Top Panel

- Pass wire through the holes of all the four eye bolts (See [Figure 2.6](#)).

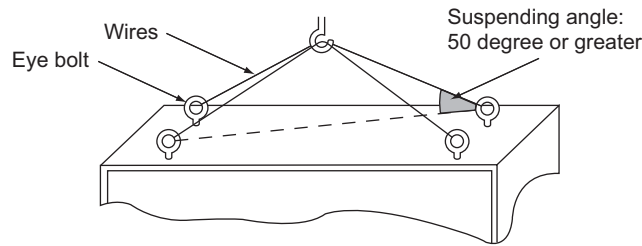


Figure 2.6 State of Suspension with Wires

- Take up the slack in the wires gradually with a crane, and when the wires are confirmed to have stretched tight, hoist the drive.
- When ready to install the drive in the enclosure panel, lower the drive. Halt lowering once when the drive has reached near the floor, and then lower the drive again very slowly.

## ◆ Digital Operator Remote Usage

### ■ Remote Operation

The digital operator mounted on the drive can be removed and connected to the drive using an extension cable up to 3 m long. This makes it easier to operate the drive when it is installed in a location where it can not be accessed easily.

The digital operator can also be permanently mounted in a remote location like a panel door. An extension cable and an installation support set (depending on the installation type) will be required.

**Note:** Refer to [Drive Options and Peripheral Devices on page 333](#) for information on extension cables and installation support sets.

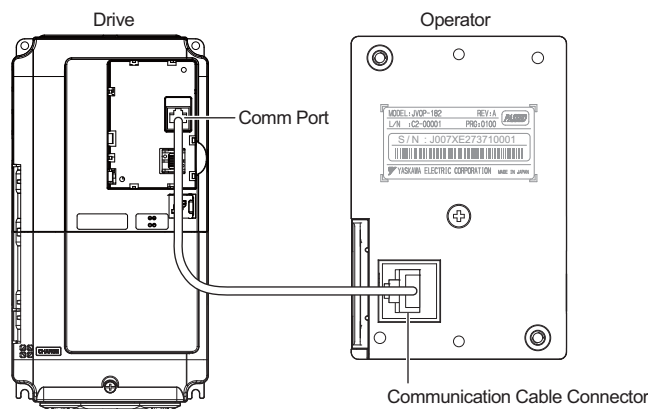


Figure 2.7 Communication Cable Connection

### ■ Digital Operator Remote Installation

#### Digital Operator Dimensions

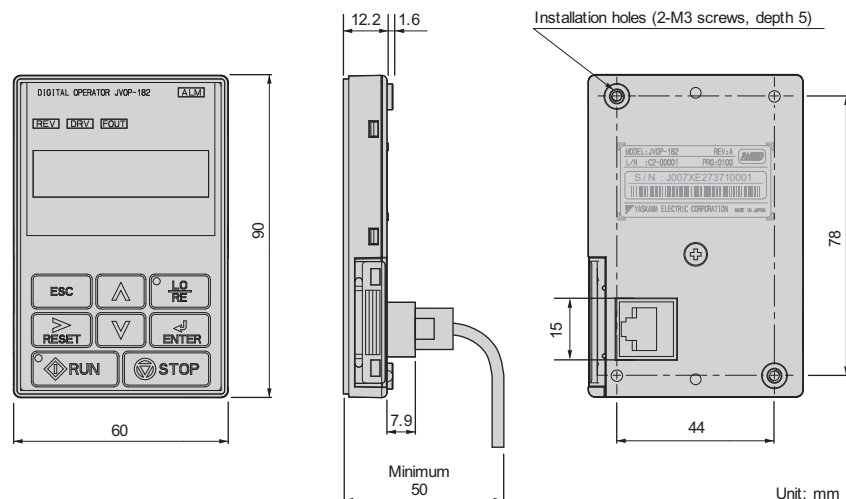


Figure 2.8 Digital Operator Dimensions

## 2.2 Mechanical Installation

### Installation Types and Required Materials

There are two ways the digital operator can be mounted to an enclosure:

1. External/face-mount installs the operator outside the enclosure panel
2. Internal/flush-mount installs the operator inside the enclosure panel

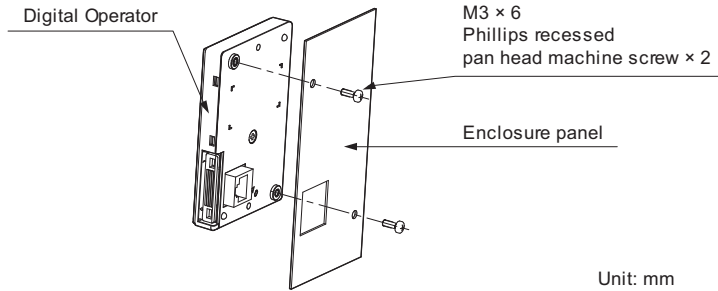
**Table 2.2 Digital Operator Installation Methods and Required Tools**

Installation Method	Description	Installation Support Sets	Model	Required Tools
External/Face-Mount	Simplified installation with the digital operator is mounted on the outside of the panel with two screws.	–	–	Phillips screwdriver (#1)
Internal/Flush-Mount	Encloses the digital operator in the panel. The digital operator is flush with the outside of the panel.	Installation Support Set A (for mounting with screws through holes in the panel)	EZZ020642A	Phillips screwdriver (#1, #2)
		Installation Support Set B (for use with threaded studs that are fixed to the panel)	EZZ020642B	Phillips screwdriver (#1) Wrench (7 mm)

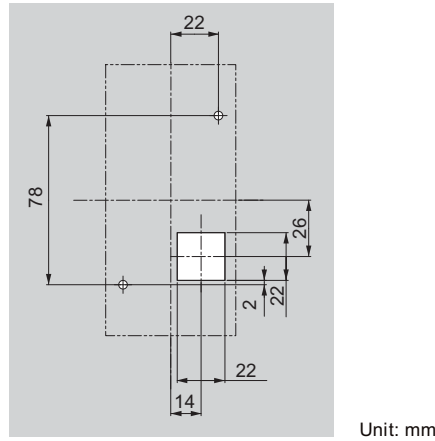
**Note:** Prevent foreign matter such as metal shavings or wire clippings from falling into the drive during installation and project construction. Failure to comply could result in damage to the drive. Place a temporary cover over the top of the drive during installation. Remove the temporary cover before startup, as the cover will reduce ventilation and cause the drive to overheat.

#### External/Face-Mount

1. Cut an opening in the enclosure panel for the digital operator as shown in [Figure 2.10](#).
2. Position the digital operator so the display faces outwards, and mount it to the enclosure panel as shown in [Figure 2.9](#).



**Figure 2.9 External/Face-Mount Installation**



**Figure 2.10 Panel Cut-Out Dimensions (External/Face-Mount Installation)**

#### Internal/Flush-Mount

An internal flush-mount requires an installation support set that must be purchased separately. Contact your Yaskawa representative to order an installation support set and mounting hardware. [Figure 2.11](#) illustrates how to attach the Installation Support Set A.

1. Cut an opening in the enclosure panel for the digital operator as shown in [Figure 2.12](#).
2. Mount the digital operator to the installation support.
3. Mount the installation support set and digital operator to the enclosure panel.



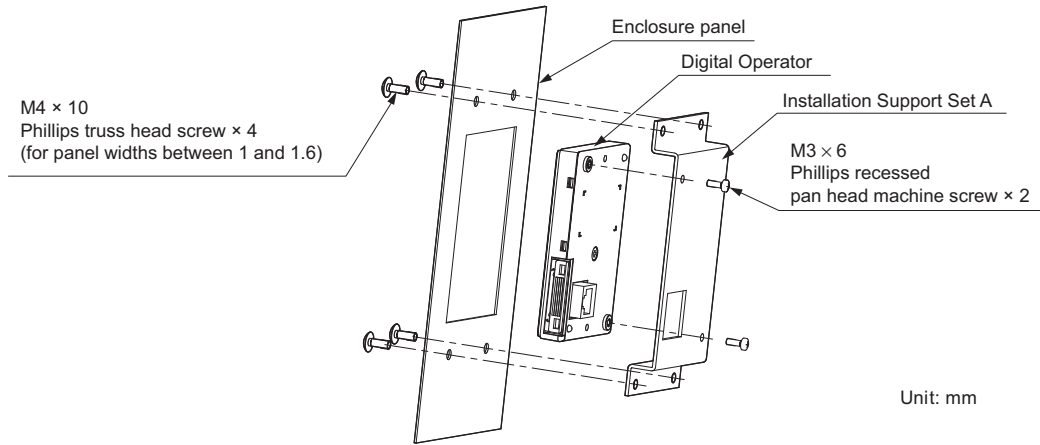


Figure 2.11 Internal/Flush Mount Installation

**Note:** For environments with a significant amount of dust or other airborne debris, use a gasket between the enclosure panel and the digital operator.

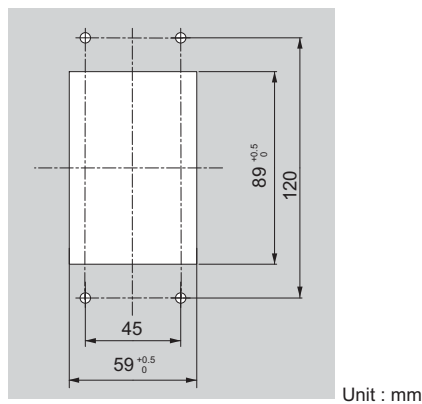


Figure 2.12 Panel Cut-Out Dimensions (Internal/Flush-Mount Installation)

◆ Exterior and Mounting Dimensions

Table 2.3 Drive Models and Types

Protective Design	Drive Model CIMR-E□		Page
	Three-Phase 200 V Class	Three-Phase 400 V Class	
IP20/NEMA Type 1 Enclosure	2A0004F	4A0002F	50
	2A0006F	4A0004F	
	2A0008F	4A0005F	
	2A0010F	4A0007F	
	2A0012F	4A0009F	
	2A0018F	4A0011F	
	2A0021F	4A0018F	
	2A0030F	4A0023F	
	2A0040F	4A0031F	
	2A0056F	4A0038F	
	2A0069F	4A0044F	
	2A0081F		
IP00 Enclosure	2A0110A	4A0058A	52
	2A0138A	4A0072A	
	2A0169A	4A0088A	
	2A0211A	4A0103A	
	2A0250A	4A0139A	
	2A0312A	4A0165A	
	2A0360A	4A0208A	
	2A0415A	4A0250A	
		4A0296A	
		4A0362A	
		4A0414A	
		4A0515A	
		4A0675A	
	4A0930A		
	4A1200A		

## 2.2 Mechanical Installation

### ■ IP20/NEMA Type 1 Enclosure Drives

**Note:** IP20/NEMA Type 1 enclosure drives are equipped with a top cover. Removing this cover voids NEMA Type 1 protection but still keeps IP20 conformity.

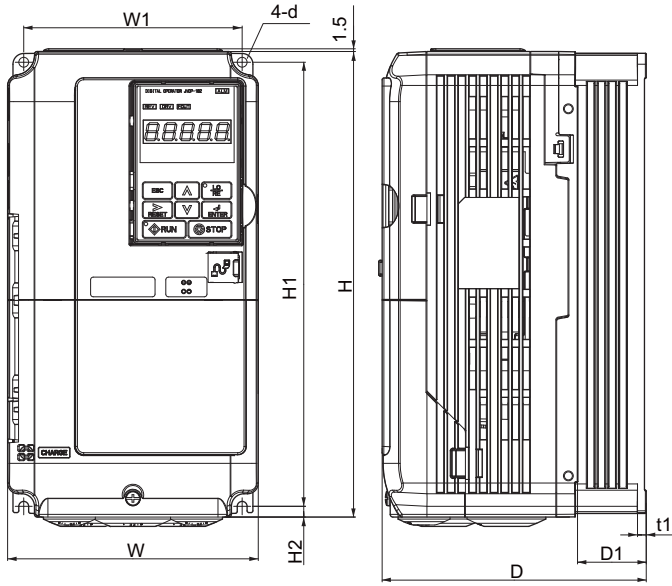


Figure 1

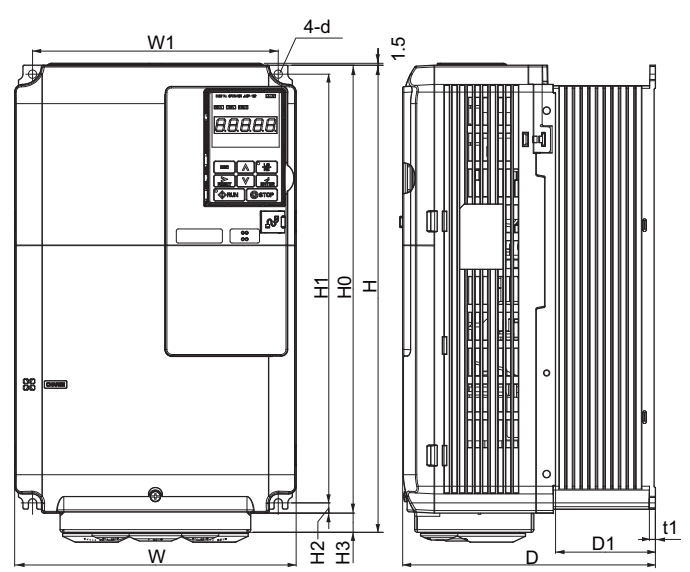


Figure 2

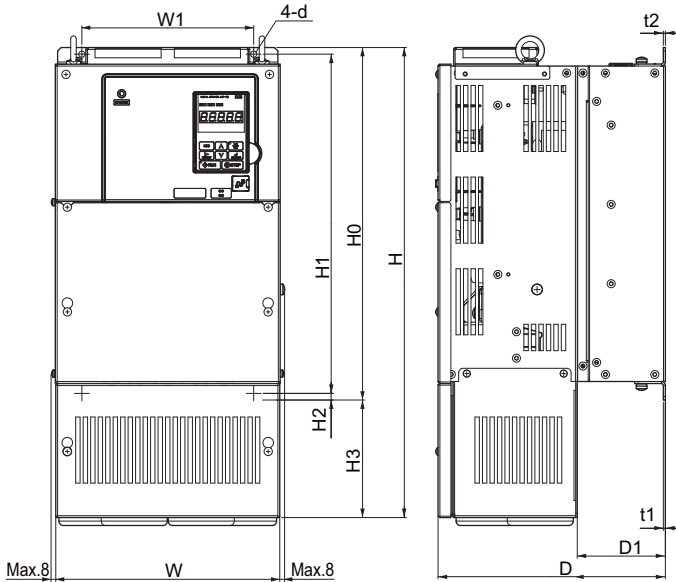


Figure 3

**Table 2.4 Dimensions for IP20/NEMA Type 1 Enclosure: 200 V Class**

Drive Model CIMR-E□2A	Dimensions (mm)													Weight (kg)
	Figure	W	H	D	W1	H0	H1	H2	H3	D1	t1	t2	d	
0004	1 <D>	140	260	147	122	—	248	6	—	38	5	—	M5	3.1
0006		140	260	147	122	—	248	6	—	38	5	—	M5	3.1
0008		140	260	147	122	—	248	6	—	38	5	—	M5	3.2
0010		140	260	147	122	—	248	6	—	38	5	—	M5	3.2
0012		140	260	147	122	—	248	6	—	38	5	—	M5	3.2
0018		140	260	164	122	—	248	6	—	55	5	—	M5	3.5
0021		140	260	164	122	—	248	6	—	55	5	—	M5	3.5
0030		140	260	167	122	—	248	6	—	55	5	—	M5	4.0
0040		140	260	167	122	—	248	6	—	55	5	—	M5	4.0
0056		180	300	187	160	—	284	8	—	75	5	—	M5	5.6
0069		220	350	197	192	—	335	8	—	78	5	—	M6	8.7
0081	2 <D>	220	365	197	192	350	335	8	15	78	5	—	M6	9.7

Drive Model CIMR-E□2A	Dimensions (mm)													
	Figure	W	H	D	W1	H0	H1	H2	H3	D1	t1	t2	d	Weight (kg)
0110	3 <2>	254	534	258	195	400	385	7.5	134	100	2.3	2.3	M6	23
0138		279	614	258	220	450	435	7.5	164	100	2.3	2.3	M6	28
0169		329	730	283	260	550	535	7.5	180	110	2.3	2.3	M6	41
0211		329	730	283	260	550	535	7.5	180	110	2.3	2.3	M6	42
0250		456	960	330	325	705	680	12.5	255	130	3.2	3.2	M10	83
0312		456	960	330	325	705	680	12.5	255	130	3.2	3.2	M10	88
0360		504	1168	350	370	800	773	13	368	130	4.5	4.5	M12	108

<1> Removing the top protective cover from a IP20/NEMA Type 1 drive voids NEMA Type 1 protection but still keeps IP20 conformity.

<2> Special order required. Contact your Yaskawa sales representative.

**Table 2.5 Dimensions for IP20/NEMA Type 1 Enclosure: 400 V Class**

Drive Model CIMR-E□4A	Dimensions (mm)														
	Figure	W	H	D	W1	H0	H1	H2	H3	D1	t1	t2	d	Weight (kg)	
0002	1 <1>	140	260	147	122	–	248	6	–	38	5	–	M5	3.2	
0004		140	260	147	122	–	248	6	–	38	5	–	M5	3.2	
0005		140	260	147	122	–	248	6	–	38	5	–	M5	3.2	
0007		140	260	164	122	–	248	6	–	55	5	–	M5	3.4	
0009		140	260	164	122	–	248	6	–	55	5	–	M5	3.5	
0011		140	260	164	122	–	248	6	–	55	5	–	M5	3.5	
0018		140	260	167	122	–	248	6	–	55	5	–	M5	3.9	
0023		140	260	167	122	–	248	6	–	55	5	–	M5	3.9	
0031		180	300	167	160	–	284	8	–	55	5	–	M5	5.4	
0038		180	300	187	160	–	284	8	–	75	5	–	M5	5.7	
0044		220	350	197	192	–	335	8	–	78	5	–	M6	8.3	
0058		3 <2>	254	465	258	195	400	385	7.5	65	100	2.3	2.3	M6	23
0072			279	515	258	220	450	435	7.5	65	100	2.3	2.3	M6	27
0088	329		630	258	260	510	495	7.5	120	105	2.3	3.2	M6	39	
0103	329		630	258	260	510	495	7.5	120	105	2.3	3.2	M6	39	
0139	329		730	283	260	550	535	7.5	180	110	2.3	2.3	M6	45	
0165	329		730	283	260	550	535	7.5	180	110	2.3	2.3	M6	46	
0208	456		960	330	325	705	680	12.5	255	130	3.2	3.2	M10	87	
0250	504		1168	350	370	800	773	13	368	130	4.5	4.5	M12	106	
0296	504		1168	350	370	800	773	13	368	130	4.5	4.5	M12	112	
0362	504		1168	350	370	800	773	13	368	130	4.5	4.5	M12	117	

<1> Removing the top protective cover from a IP20/NEMA Type 1 drive voids NEMA Type 1 protection but still keeps IP20 conformity.

<2> Special order required. Contact your Yaskawa sales representative.

## 2.2 Mechanical Installation

### ■ IP00 Enclosure Drives

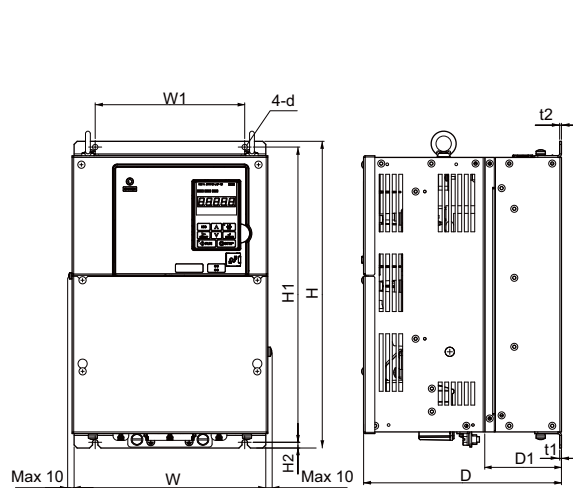


Figure 1

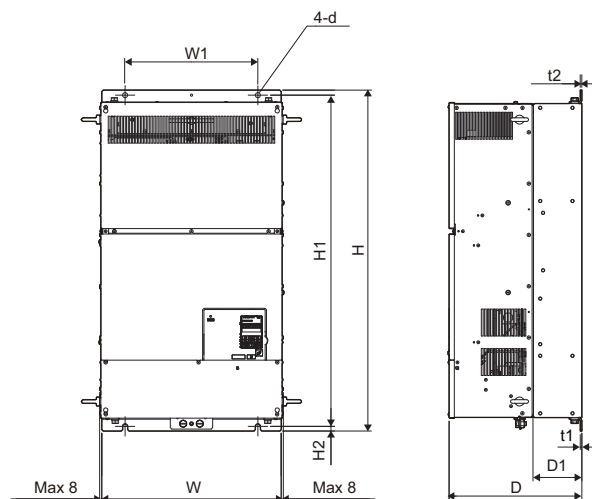


Figure 2

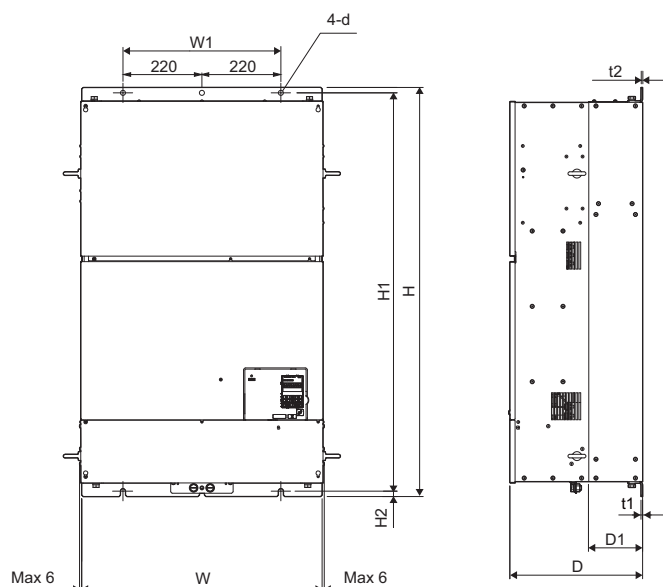


Figure 3

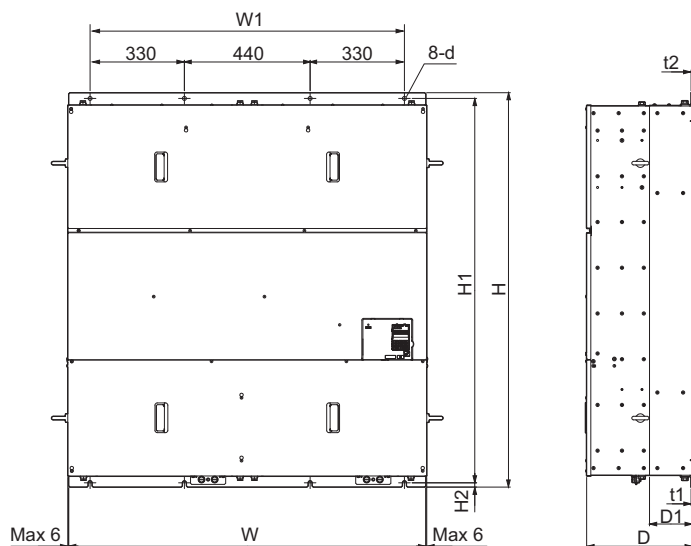


Figure 4

**Table 2.6 Dimensions for IP00 Enclosure: 200 V Class**

Drive Model CIMR-E□2A	Dimensions (mm)											Weight (kg)
	Figure	W	H	D	W1	H1	H2	D1	t1	t2	d	
0110	1	250	400	258	195	385	7.5	100	2.3	2.3	M6	21
0138		275	450	258	220	435	7.5	100	2.3	2.3	M6	25
0169		325	550	283	260	535	7.5	110	2.3	2.3	M6	37
0211		325	550	283	260	535	7.5	110	2.3	2.3	M6	38
0250		450	705	330	325	680	12.5	130	3.2	3.2	M10	76
0312		450	705	330	325	680	12.5	130	3.2	3.2	M10	80
0360		500	800	350	370	773	13	130	4.5	4.5	M12	98
0415		500	800	350	370	773	13	130	4.5	4.5	M12	99

Table 2.7 Dimensions for IP00 Enclosure: 400 V Class

Drive Model CIMR-E□4A	Dimensions (mm)											Weight (kg)
	Figure	W	H	D	W1	H1	H2	D1	t1	t2	d	
0058	1	250	400	258	195	385	7.5	100	2.3	2.3	M6	21
0072		275	450	258	220	435	7.5	100	2.3	2.3	M6	25
0088		325	510	258	260	495	7.5	105	2.3	3.2	M6	36
0103		325	510	258	260	495	7.5	105	2.3	3.2	M6	36
0139		325	550	283	260	535	7.5	110	2.3	2.3	M6	41
0165		325	550	283	260	535	7.5	110	2.3	2.3	M6	42
0208		450	705	330	325	680	12.5	130	3.2	3.2	M10	79
0250		500	800	350	370	773	13	130	4.5	4.5	M12	96
0296		500	800	350	370	773	13	130	4.5	4.5	M12	102
0362		500	800	350	370	773	13	130	4.5	4.5	M12	107
0414	2	500	950	370	370	923	13	135	4.5	4.5	M12	125
0515	3	670	1140	370	440	1110	15	150	4.5	4.5	M12	216
0675		670	1140	370	440	1110	15	150	4.5	4.5	M12	221
0930	4	1250	1380	370	1110	1345	15	150	4.5	4.5	M12	545
1200		1250	1380	370	1110	1345	15	150	4.5	4.5	M12	555



# Electrical Installation

---

This chapter explains proper procedures for wiring the control circuit terminals, motor, and power supply.

<b>3.1 SECTION SAFETY</b> .....	<b>56</b>
<b>3.2 STANDARD CONNECTION DIAGRAM</b> .....	<b>58</b>
<b>3.3 MAIN CIRCUIT CONFIGURATIONS</b> .....	<b>61</b>
<b>3.4 TERMINAL BLOCK CONFIGURATION</b> .....	<b>64</b>
<b>3.5 TERMINAL COVER</b> .....	<b>66</b>
<b>3.6 DIGITAL OPERATOR AND FRONT COVER</b> .....	<b>68</b>
<b>3.7 TOP PROTECTIVE COVER</b> .....	<b>71</b>
<b>3.8 MAIN CIRCUIT WIRING</b> .....	<b>72</b>
<b>3.9 CONTROL CIRCUIT WIRING</b> .....	<b>79</b>
<b>3.10 CONTROL I/O CONNECTIONS</b> .....	<b>85</b>
<b>3.11 TERMINAL A2 ANALOG INPUT SIGNAL SELECTION</b> .....	<b>88</b>
<b>3.12 CONNECT TO A PC</b> .....	<b>89</b>
<b>3.13 MEMOBUS/MODBUS TERMINATION</b> .....	<b>90</b>
<b>3.14 EXTERNAL INTERLOCK</b> .....	<b>91</b>
<b>3.15 WIRING CHECKLIST</b> .....	<b>92</b>

# 3.1 Section Safety

### DANGER

#### Electrical Shock Hazard

**Do not connect or disconnect wiring while the power is on.**

Failure to comply will result in death or serious injury.

### WARNING

#### Electrical Shock Hazard

**Do not operate equipment with covers removed.**

Failure to comply could result in death or serious injury.

The diagrams in this section may show drives without covers or safety shields to show details. Be sure to reinstall covers or shields before operating the drives and run the drives according to the instructions described in this manual.

**Make sure the protective earthing conductor complies with technical standards and local safety regulations.**

Because the leakage current exceeds 3.5 mA in models CIMR-E□4A0414 and larger, IEC 61800-5-1 states that either the power supply must be automatically disconnected in case of discontinuity of the protective earthing conductor or a protective earthing conductor with a cross-section of at least 10 mm<sup>2</sup> (Cu) or 16 mm<sup>2</sup> (Al) must be used. Failure to comply may result in death or serious injury.

**Use appropriate equipment for electric leakage circuit breaker (ELCB).**

This drive can cause a residual current with a DC component in the protective earthing conductor. Where a residual current operated protective or monitoring device is used for protection in case of direct or indirect contact, always use an ELCB of type B according to IEC 60755.

**Always ground the motor-side grounding terminal.**

Improper equipment grounding could result in death or serious injury by contacting the motor case.

**Do not perform work on the drive while wearing loose clothing, jewelry or without eye protection.**

Failure to comply could result in death or serious injury.

Remove all metal objects such as watches and rings, secure loose clothing, and wear eye protection before beginning work on the drive.

**Do not remove covers or touch circuit boards while the power is on.**

Failure to comply could result in death or serious injury.

**Do not allow unqualified personnel to perform work on the drive.**

Failure to comply could result in death or serious injury.

Installation, maintenance, inspection, and servicing must be performed only by authorized personnel familiar with installation, adjustment, and maintenance of AC drives.

**Do not touch any terminals before the capacitors have fully discharged.**

Failure to comply could result in death or serious injury.

Before wiring terminals, disconnect all power to the equipment. The internal capacitor remains charged even after the power supply is turned off. After shutting off the power, wait for at least the amount of time specified on the drive before touching any components.

#### Fire Hazard

**Tighten all terminal screws to the specified tightening torque.**

Loose electrical connections could result in death or serious injury by fire due to overheating of electrical connections.

**Do not use improper combustible materials.**

Failure to comply could result in death or serious injury by fire.

Do not install the drive to a combustible surface. Never place combustible materials on the drive.



**⚠ WARNING****Do not use an improper voltage source.**

Failure to comply could result in death or serious injury by fire.

Verify that the rated voltage of the drive matches the voltage of the incoming power supply before applying power.

**When installing dynamic braking options, perform all wiring exactly as specified in the wiring diagrams provided.**

Failure to do so can result in fire. Improper wiring may damage braking components.

**⚠ CAUTION****Do not carry the drive by the front cover or the terminal cover.**

Failure to comply may cause the main body of the drive to fall, resulting in minor or moderate injury.

**NOTICE****If a fuse is blown or equipment for residual current monitoring/detection (RCM/RCD) is tripped, check the wiring and the selection of the peripheral devices.**

Contact your supplier if the cause cannot be identified after checking the above.

**Do not restart the drive until 5 minutes passes and CHARGE lamp is OFF or immediately operate the peripheral devices if a fuse is blown or equipment for residual current monitoring/detection (RCM/RCD) is tripped.**

Check the wiring and the selection of peripheral devices to identify the cause.

Contact your supplier before restarting the drive or the peripheral devices if the cause cannot be identified.

**For models CIMR-E□4A0930 and 4A1200, make sure to install a fuse and equipment for residual current monitoring/detection (RCM/RCD).**

Failure to comply may result in serious damage to the facilities in case the drive is defected.

**Observe proper electrostatic discharge procedures (ESD) when handling the drive and circuit boards.**

Failure to comply may result in ESD damage to the drive circuitry.

**Never connect or disconnect the motor from the drive while the drive is outputting voltage.**

Improper equipment sequencing could result in damage to the drive.

**Do not use unshielded cable for control wiring.**

Failure to comply may cause electrical interference resulting in poor system performance. Use shielded, twisted-pair wires and ground the shield to the ground terminal of the drive.

**Do not allow unqualified personnel to use the product.**

Failure to comply could result in damage to the drive or braking circuit.

Carefully review instruction manual TOBPC72060000 when connecting a dynamic braking option to the drive.

**Do not modify the drive circuitry.**

Failure to comply could result in damage to the drive and will void warranty.

Yaskawa is not responsible for any modification of the product made by the user. This product must not be modified.

**Check all the wiring to ensure that all connections are correct after installing the drive and connecting any other devices.**

Failure to comply could result in damage to the drive.

### 3.2 Standard Connection Diagram

Connect the drive and peripheral devices as shown in [Figure 3.1](#). It is possible to set and run the drive via the digital operator without connecting digital I/O wiring. This section does not discuss drive operation; [Refer to Start-Up Programming & Operation on page 95](#) for instructions on operating the drive.

**NOTICE:** *Inadequate wiring could result in damage to the drive. Install adequate branch circuit short circuit protection per applicable codes. The drive is suitable for circuits capable of delivering not more than 100,000 RMS symmetrical amperes, 240 Vac maximum (200 V Class) and 480 Vac maximum (400 V Class).*

**NOTICE:** *When the input voltage is 440 V or higher or the wiring distance is greater than 100 meters, pay special attention to the motor insulation voltage or use a drive duty motor. Failure to comply could lead to motor insulation breakdown.*

**NOTICE:** *Do not connect AC control circuit ground to drive enclosure. Improper drive grounding can cause control circuit malfunction.*

**NOTICE:** *The minimum load for the relay outputs M1-M2, M3-M4, M5-M6, and MA-MB-MC is 10 mA.*

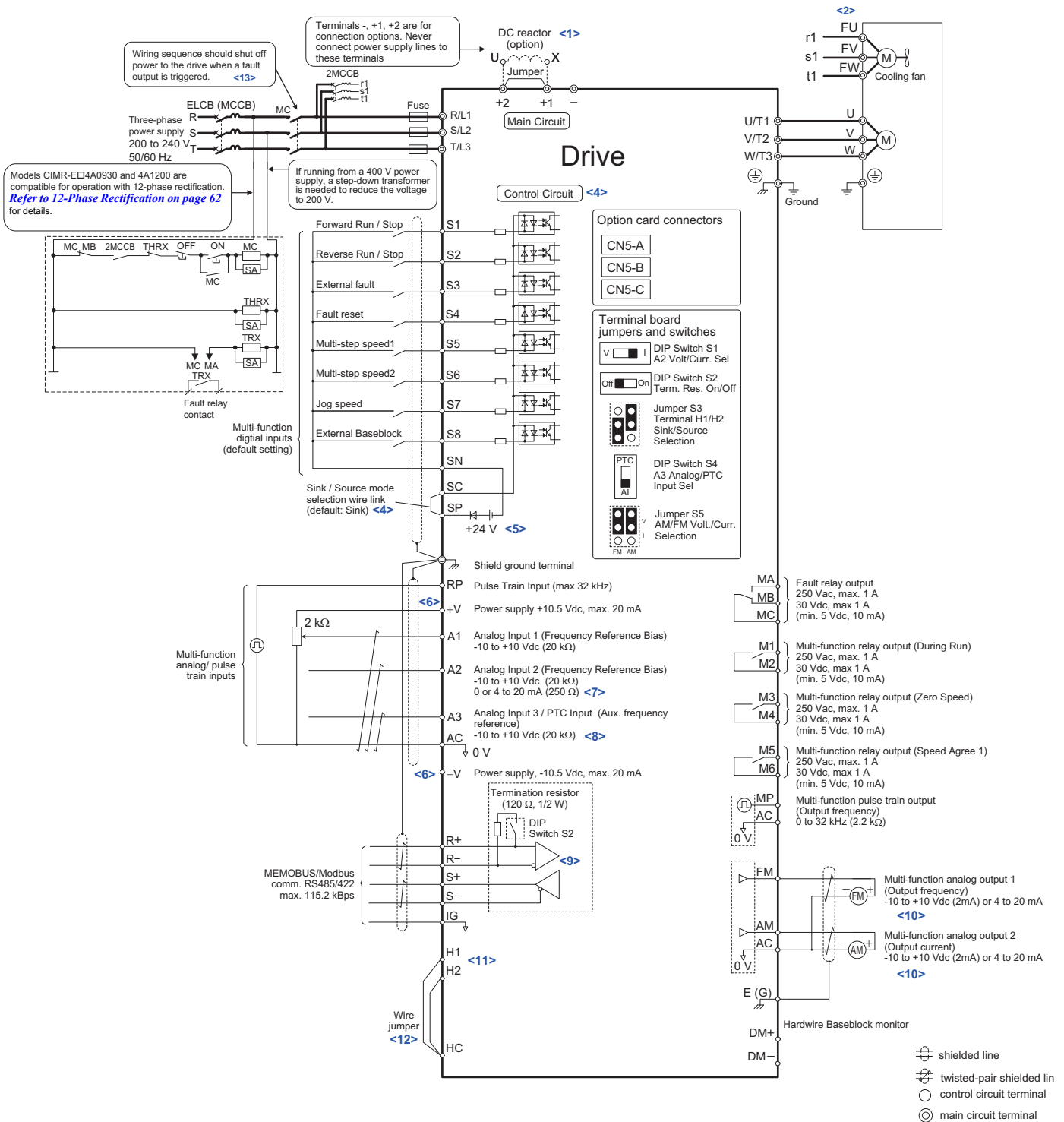


Figure 3.1 Drive Standard Connection Diagram (example: CIMR-E□2A0040)

- <1> Remove the jumper when installing a DC reactor. Models CIMR-E□2A0110 through 2A0415 and 4A0058 through 4A1200 come with a built-in DC reactor.
- <2> Self-cooling motors do not require wiring that would be necessary with motors using a cooling fan.
- <3> Supplying power to the control circuit separately from the main circuit requires a 24 V power supply (option).
- <4> This figure shows an example of a sequence input to S1 through S8 using a non-powered relay or an NPN transistor. Install the wire link between terminals SC-SP for Sink mode and SC-SN for Source mode. Leave it out for external power supply. Never short terminals SP and SN as doing so will damage the drive.
- <5> The maximum current supplied by this voltage source is 150 mA.
- <6> The maximum output current capacity for the +V and -V terminals on the control circuit is 20 mA. Never short terminals +V, -V, and AC, as this can cause erroneous operation or damage the drive.
- <7> Set DIP switch S1 to select between a voltage or current input signal to terminal A2. The default setting is for current input.
- <8> Set DIP switch S4 to select between analog or PTC input for terminal A3.
- <9> Enable the termination resistor in the last drive in a MEMOBUS network by setting DIP switch S2 to the ON position.
- <10> Monitor outputs work with devices such as analog frequency meters, ammeters, voltmeters, and wattmeters. They are not intended for use as a feedback-type of signal.

## 3.2 Standard Connection Diagram

---

- <11> Use jumper S3 to select between Sink Mode, Source Mode or External Power supply for Hardwire Baseblock Inputs.
- <12> Disconnect the wire jumper between H1-HC, H2-HC when utilizing the Hardwire Baseblock Inputs.
- <13> Note that if the drive is set to trigger a fault output whenever the fault restart function is activated (L5-02 = 1), then a sequence to interrupt power when a fault occurs will result in shutting off the power to the drive as the drive attempts to restart itself. The default setting for L5-02 is 0 (fault output not active during restart attempt).

**WARNING!** *Sudden Movement Hazard. Do not close the wiring for the control circuit unless the multifunction input terminal parameters are properly set. Improper sequencing of run/stop circuitry could result in death or serious injury from moving equipment.*

**WARNING!** *Sudden Movement Hazard. Ensure start/stop and Hardwire Baseblock circuits are wired properly and in the correct state before energizing the drive. Failure to comply could result in death or serious injury from moving equipment. When programmed for 3-Wire control, a momentary closure on terminal S1 may cause the drive to start.*

**WARNING!** *When 3-Wire sequence is used, set the drive to 3-Wire sequence before wiring the control terminals and ensure parameter b1-17 is set to 0 (drive does not accept a run command at power up (default)). If the drive is wired for 3-Wire sequence but set up for 2-Wire sequence (default) and if parameter b1-17 is set to 1 (drive accepts a Run command at power up), the motor will rotate in reverse direction at power up of the drive and may cause injury.*

**WARNING!** *When the application preset function is executed (or A1-06 is set to any value other than 0) the drive I/O terminal functions change. This may cause unexpected operation and potential damage to equipment or injury.*

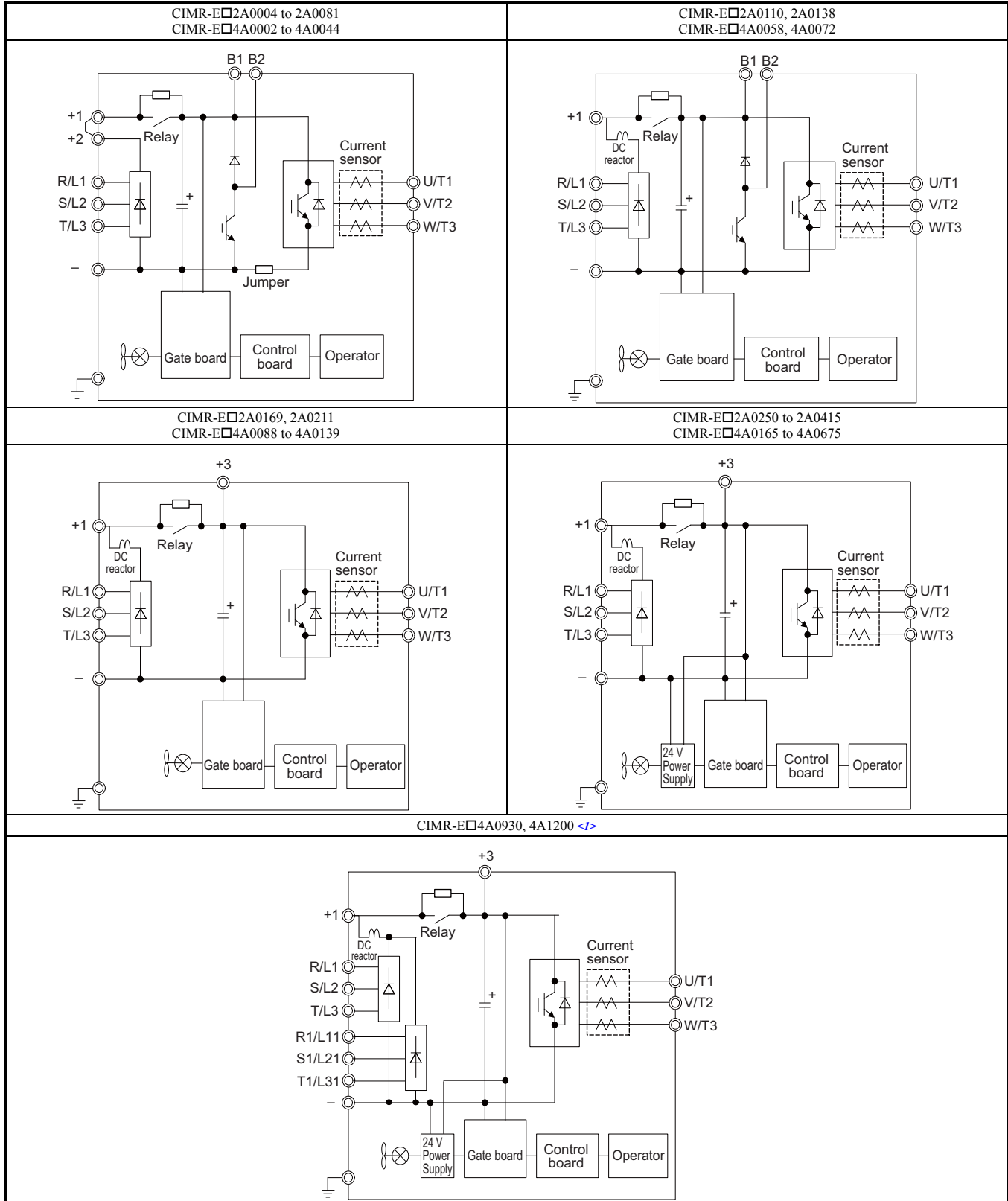
**WARNING!** *When using the automatic fault restart function while the wiring is made to shut off the power supply when a drive fault occurs, make sure the drive is set not to trigger a fault output during fault restart (L5-02=0, default). Otherwise the fault restart function can not work properly.*

### 3.3 Main Circuit Configurations

Refer to the [Table 3.1](#) when wiring the drive's main circuit. Connections may vary based on drive capacity. The DC power supply for the main circuit also provides power to the control circuit.

**NOTICE:** Do not use the negative DC bus terminal “-” as a ground terminal. This terminal is at high DC voltage potential. Improper wiring connections could damage the drive.

**Table 3.1 Drive main circuit configurations**



<1> Models CIMR-E□4A0930 and 4A1200 are compatible for operation with 12-phase rectification. Refer to [12-Phase Rectification on page 62](#) for details.

#### ◆ 12-Phase Rectification

##### ■ Removing the Jumper

Models CIMR-E□4A0930 and 4A1200 are compatible for operation with 12-phase rectification. Operation with 12-phase rectification requires the user to separately prepare a 3-winding transformer for the power supply. Contact Yaskawa or your nearest sales representative for the transformer specifications.

**WARNING! Fire Hazard.** Failure to remove jumpers shorting the power supply terminals on the main circuit when operating with 12-phase rectification may cause death or serious injury by fire.

##### ■ Application Notes

- Remove M5 screws and then jumpers to operate with 12-phase rectification as shown in [Figure 3.2](#).
- Models CIMR-E□4A0930 and 4A1200 are shipped from the factory with jumpers short-circuiting terminals R/L1-R1/L11, S/L2-S1/L21, and T/L3-T1/L31.

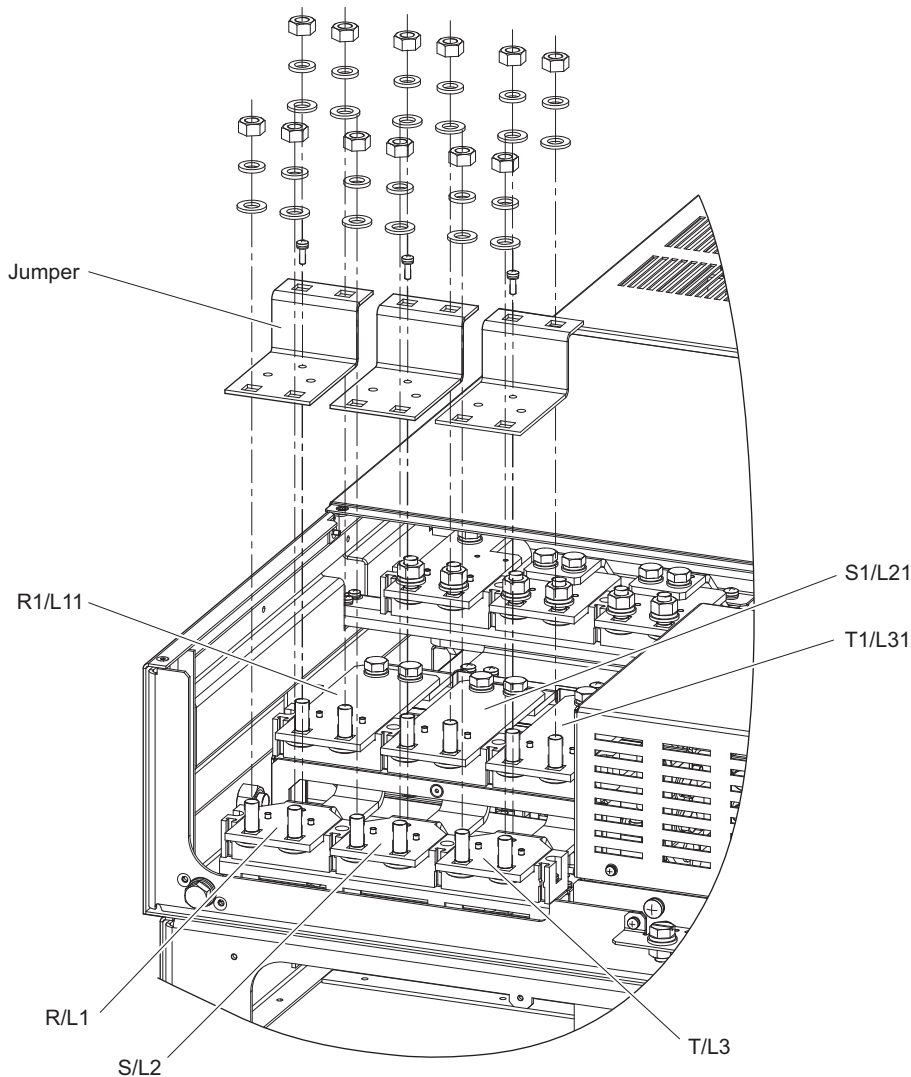


Figure 3.2 Removing the Jumper

■ Connection Diagram

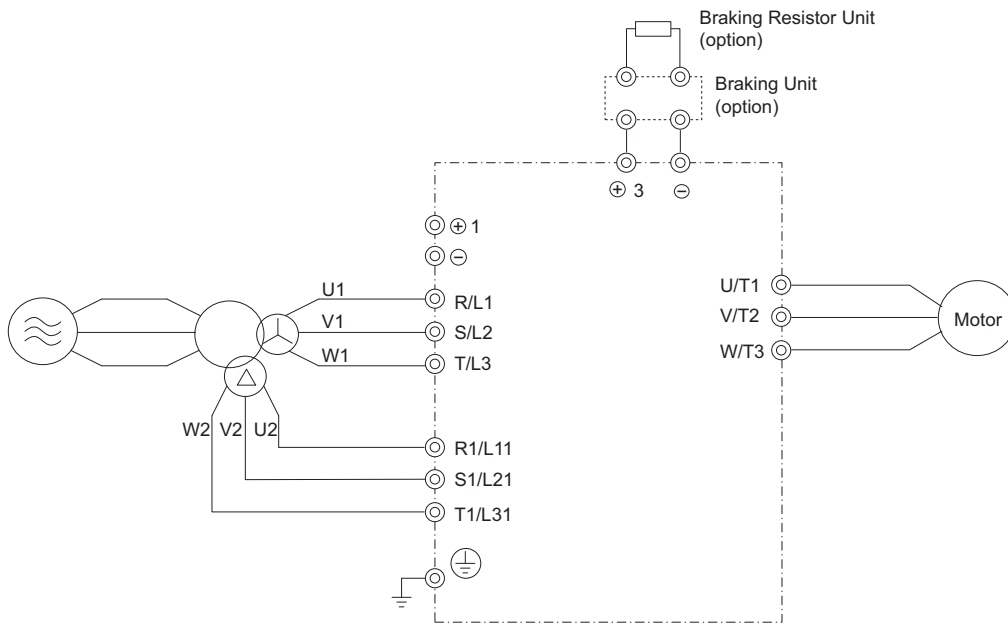
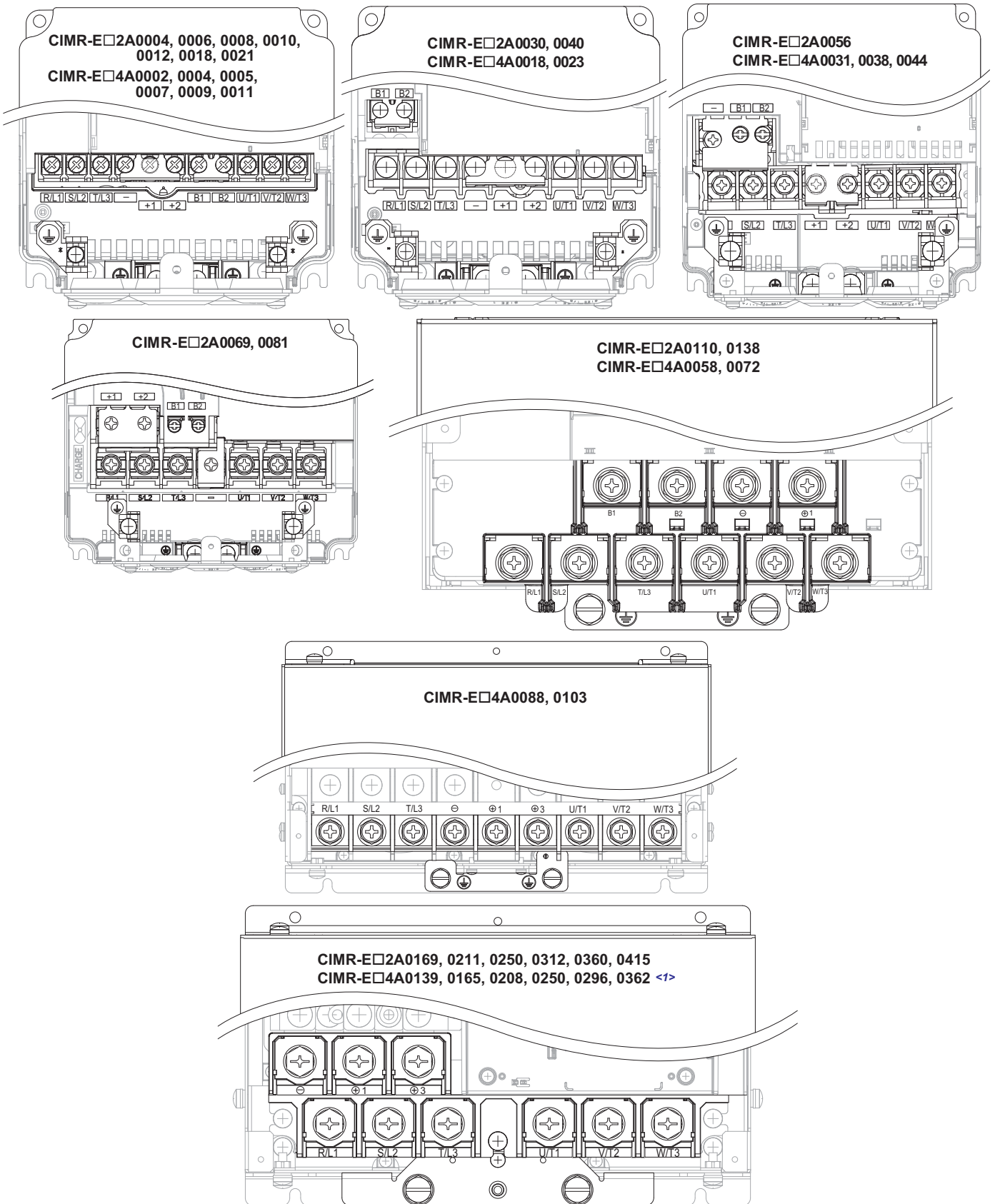


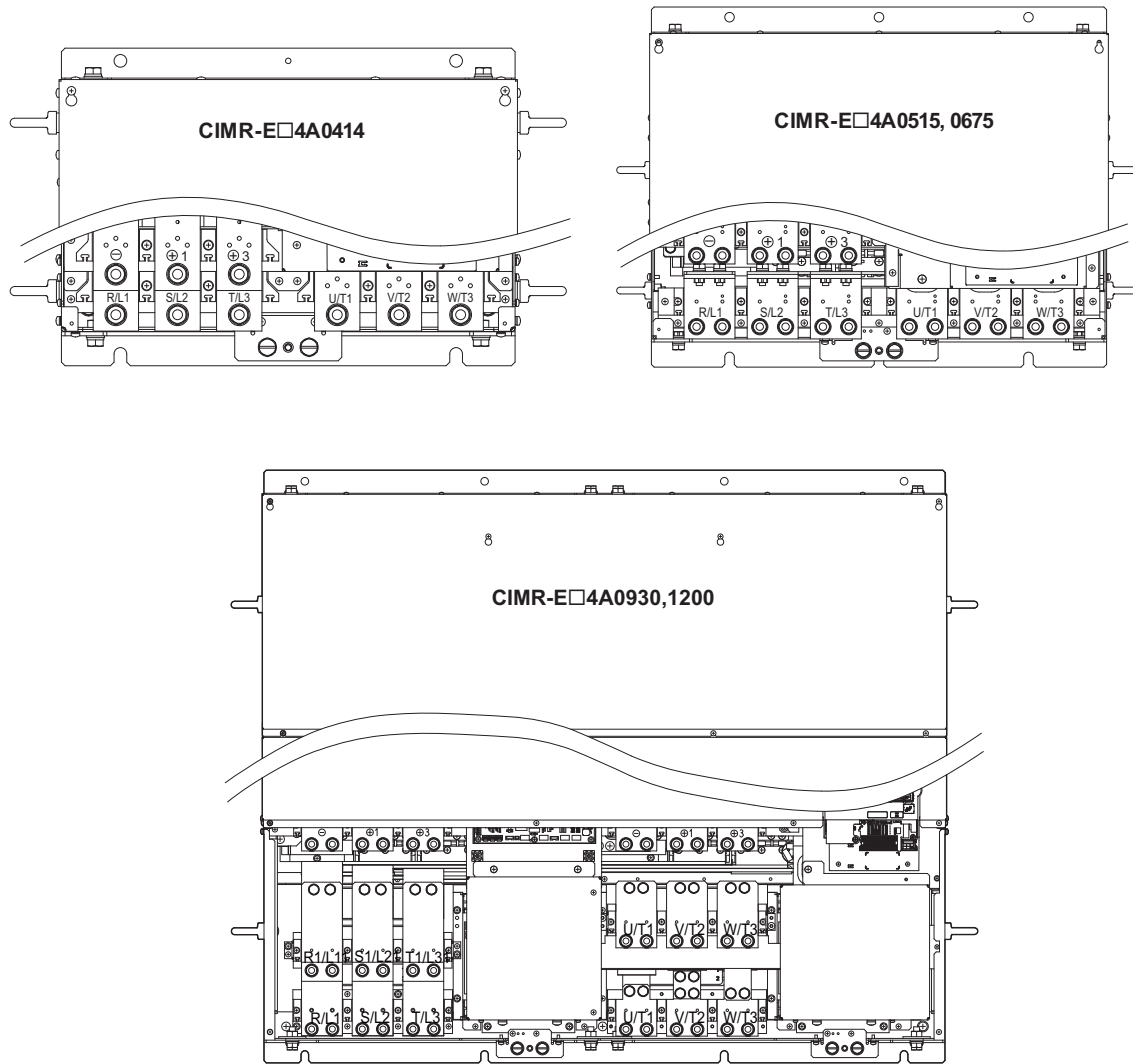
Figure 3.3 Connecting Main Circuit Terminals

## 3.4 Terminal Block Configuration

Figure 3.4 shows the different main circuit terminal arrangements for the drive capacities.







**Figure 3.4 Main Circuit Terminal Block Configuration**

<1> Terminal block design differs slightly for models CIMR-E□2A0250 through 2A0415 and 4A0208 through 4A0362.

## 3.5 Terminal Cover

Follow the procedure below to remove the terminal cover for wiring and to reattach the terminal cover after wiring is complete.

### ◆ CIMR-E□2A0004 to 0081, 4A0002 to 0044 (IP20/NEMA Type 1 Enclosure)

#### ■ Removing the Terminal Cover

1. Loosen the terminal cover screw.

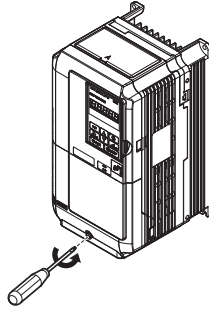


Figure 3.5 Removing the Terminal Cover on an IP20/NEMA Type 1 Enclosure Drive

2. Push in on the hook located on the bottom of the terminal cover, and gently pull forward. This should remove the terminal cover.

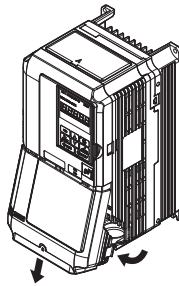


Figure 3.6 Removing the Terminal Cover on an IP20/NEMA Type 1 Enclosure Drive

#### ■ Reattaching the Terminal Cover

Power lines and signal wiring should pass through the opening provided. *Refer to Wiring the Main Circuit Terminal on page 78 and Wiring the Control Circuit Terminal on page 83 for details on wiring.*

After all wiring to the drive and other devices is complete, reattach the terminal cover.

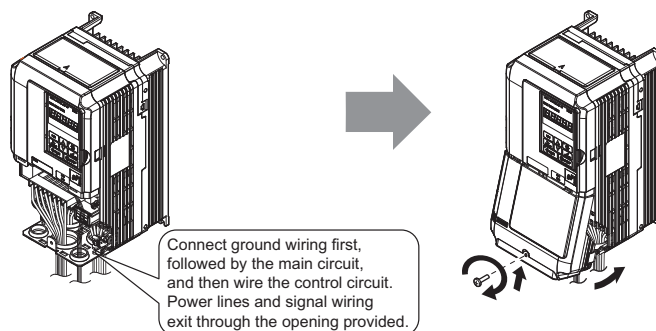


Figure 3.7 Reattaching the Terminal Cover on an IP20/NEMA Type 1 Enclosure Drive

## ◆ CIMR-E□2A0110 to 4A0415, 4A0058 to 4A1200 (IP00 Enclosure)

### ■ Removing the Terminal Cover

1. Loosen the screws on the terminal cover, then pull down on the cover.

**CAUTION!** *Crush Hazard. Do not completely remove the cover screws, just loosen them. If the cover screws are removed completely, the terminal cover may fall off causing an injury. Take special care when removing/reattaching the terminal covers for larger drives.*

**Note:** The shape of the terminal covers and the numbers of screws differ depending on the drive models. *Refer to Component Names on page 32* for details.

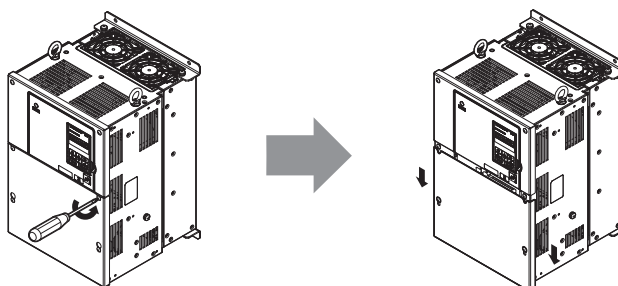


Figure 3.8 Removing the Terminal Cover on an IP00 Enclosure Drive

2. Pull forward on the terminal cover to free it from the drive.

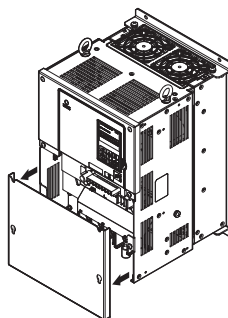


Figure 3.9 Removing the Terminal Cover on an IP00 Enclosure Drive

### ■ Reattaching the Terminal Cover

Once wiring to the terminal board and other devices is complete, double check all connections and finally reattach the terminal cover. *Refer to Wiring the Main Circuit Terminal on page 78 and Wiring the Control Circuit Terminal on page 83* for details on wiring.

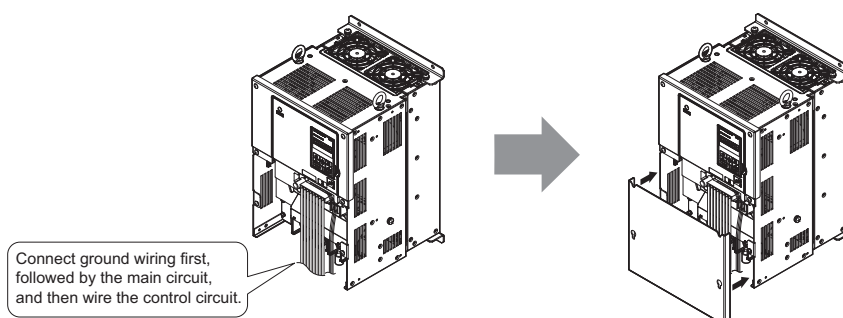


Figure 3.10 Reattaching the Terminal Cover on an IP00 Enclosure Drive

## 3.6 Digital Operator and Front Cover

The digital operator can be detached from the drive for remote operation, or when the front cover has to be opened to install an option card.

**NOTICE:** Be sure the digital operator has been removed prior to opening the front cover or reattaching it. Leaving the digital operator plugged into the drive when removing the front cover can result in erroneous operation caused by a poor connection. Before reattaching the operator make sure the front cover has been firmly fastened back into place.

### ◆ Removing/Reattaching the Digital Operator

#### ■ Removing the Digital Operator

While pinching inwards on the hook located on the right side of the digital operator, pull forward and remove the operator from the drive.

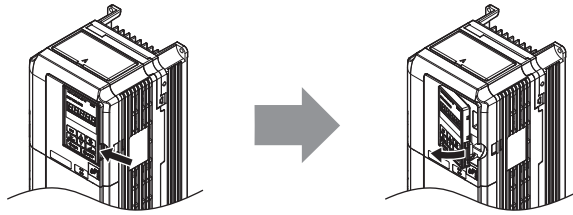


Figure 3.11 Removing the Digital Operator

#### ■ Reattaching the Digital Operator

Insert the digital operator into the opening in the top protective cover while aligning it with the notches on the left side of the opening. Next press gently on the right side of the operator until it clicks into place.

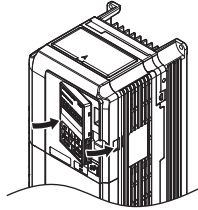


Figure 3.12 Reattaching the Digital Operator

### ◆ Removing/Reattaching the Front Cover

#### ■ Removing the Front Cover

**2A0004 to 2A0081 and 4A0002 to 4A0044**

After removing the terminal cover and the digital operator, loosen the screw that affixes the front cover (model CIMR-E□2A0056, 4A0031, 4A0038 do not use a screw to affix the front cover). Pinch inwards on hooks found on each side of the front cover, then pull forward to remove it from the drive.

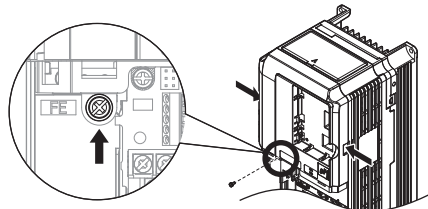


Figure 3.13 Remove the Front Cover (2A0004 to 2A0081 and 4A0002 to 4A0044)

## 2A0110 to 2A0415 and 4A0058 to 4A1200

1. Remove the terminal cover and the digital operator.
2. Loosen the installation screw on the front cover.
3. Use a straight-edge screwdriver to loosen the hooks on each side of the cover that hold it in place.

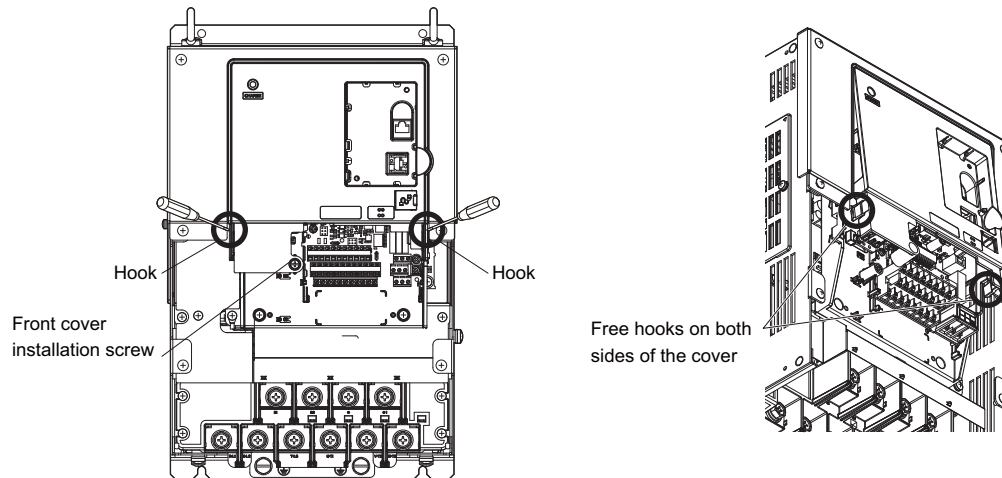


Figure 3.14 Remove the Front Cover (2A0110 to 2A0415 and 4A0058 to 4A1200)

4. First unhook the left side of the front cover, then swing the left side towards you as shown in the figure below until the cover comes off.

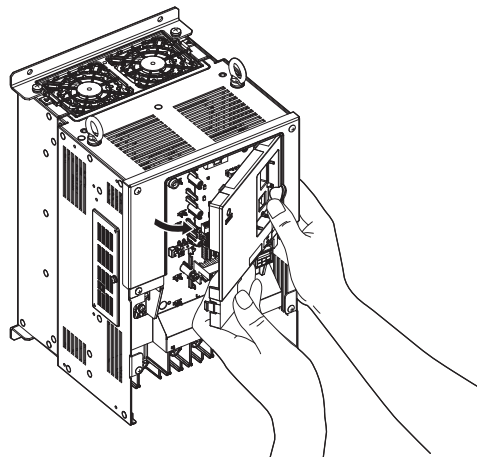


Figure 3.15 Remove the Front Cover (2A0110 to 2A0415 and 4A0058 to 4A1200)

### ■ Reattaching the Front Cover

#### 2A0004 to 2A0081 and 4A0002 to 4A0044

Reverse the instructions given in *Remove the Front Cover (2A0004 to 2A0081 and 4A0002 to 4A0044) on page 68* to reattach the front cover. Pinch inwards on the hooks found on each side of the front cover while guiding it back into the drive. Make sure it clicks firmly into place.

#### 2A0110 to 2A0415 and 4A0058 to 4A1200

1. Slide the front cover so that the hooks on the top connect to the drive.

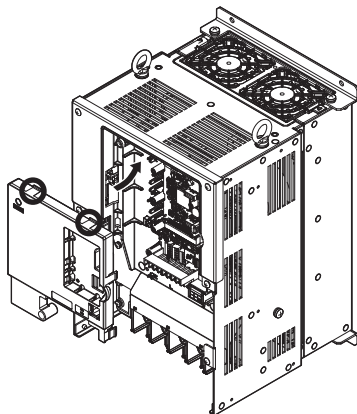


Figure 3.16 Reattach the Front Cover (2A0110 to 2A0415 and 4A0058 to 4A1200)

2. Once the hooks have connected to the drive, press firmly on the cover to make sure it locks into place.

## 3.7 Top Protective Cover

Drive models CIMR-E□2A0004 to 0081 and 4A0002 to 0058 are designed with NEMA Type 1 specifications, and have a top protective cover on the top. Removing this top protective cover voids the NEMA Type 1 conformance but still keeps a protection degree in accordance with IP20 enclosure.

### ◆ Removing the Top Protective Cover

Insert the tip of a straight-edge screwdriver into the small openings located on the front edge of the top protective cover. Gently apply pressure as shown in the figure below to free the cover from the drive.

**Note:** Removing the top protective cover from a IP20/NEMA Type 1 enclosure drive voids the NEMA Type 1 protection but still keeps IP20 conformity.

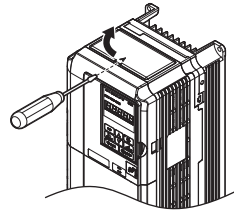


Figure 3.17 Removing the Top Protective Cover

### ◆ Reattaching the Top Protective Cover

Align the small protruding hooks on the sides of the top protective cover with the corresponding mounting holes on the top of the drive. Pinch the hooks inward so that they connect with the mounting holes and fasten the top protective cover back into place.

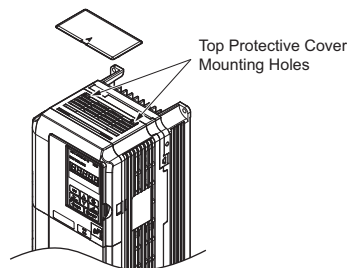


Figure 3.18 Reattaching the Top Protective Cover

## 3.8 Main Circuit Wiring

This section describes the functions, specifications, and procedures required to safely and properly wire the main circuit in the drive.

**NOTICE:** Do not solder the ends of wire connections to the drive. Soldered wiring connections can loosen over time. Improper wiring practices could result in drive malfunction due to loose terminal connections.

**NOTICE:** Do not switch the drive input to start or stop the motor. Frequently switching the drive on and off shortens the lifetime of the DC bus charge circuit and the DC bus capacitors, and can cause premature drive failures. For the full performance life, refrain from switching the drive on and off more than once every 30 minutes.

### ◆ Main Circuit Terminal Functions

Table 3.2 Main Circuit Terminal Functions

Terminal		Type				Function	Page
200 V Class	Model CIMR-E□	2A0004 to 2A0081	2A0110, 2A0138	2A0169 to 2A0415	–		
400 V Class		4A0002 to 4A0044	4A0058 to 4A0072	4A0088 to 4A0675	4A0930, 4A1200		
R/L1		Main circuit power supply input				Connects line power to the drive	59
S/L2							
T/L3							
R1-L11							
S1-L21		not available		Main circuit power supply input			
T1-L31							
U/T1		Drive output				Connects to the motor	59
V/T2							
W/T3							
+2	<ul style="list-style-type: none"> <li>DC reactor connection (+1, +2) (remove the shorting bar between +1 and +2)</li> <li>DC power supply input (+1, –)</li> </ul>	not available				For connection <ul style="list-style-type: none"> <li>of the drive to a DC power supply (terminals +1 and – are not EU or UL approved)</li> <li>of dynamic braking options</li> <li>of a DC reactor</li> </ul>	343
+1		<ul style="list-style-type: none"> <li>DC power supply input (+1, –)</li> </ul>	<ul style="list-style-type: none"> <li>DC power supply input (+1, –)</li> <li>Braking unit connection (+3, –)</li> </ul>				
–							
+3		not available					
⊕		For 200 V class: 100 Ω or less For 400 V class: 10 Ω or less				Grounding terminal	78

### ◆ Protecting Main Circuit Terminals

#### ■ Insulation Cap

Use insulation caps when wiring the drive with crimp terminals. Take particular care to ensure that wiring does not touch neighboring terminals or the surrounding case.

#### ■ Insulation Barrier

Insulation barriers are packaged with drive model CIMR-E□4A0414 through 4A1200 to provide added protection between terminals. Yaskawa recommends using the insulation barriers provided to ensure proper wiring. See [Figure 3.19](#) for instructions on where the insulation barriers should be placed.



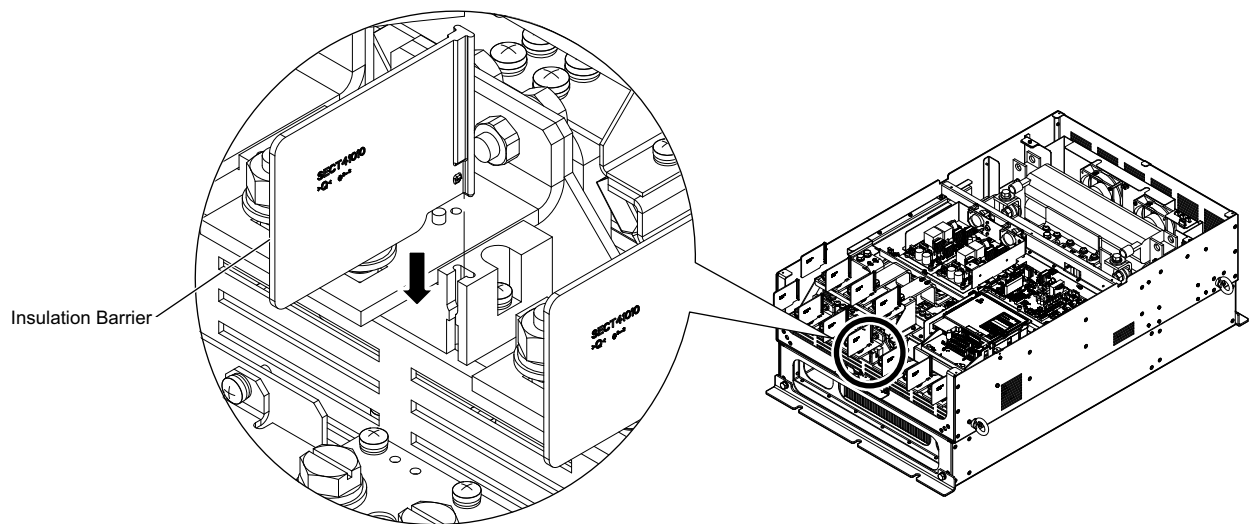


Figure 3.19 Installing insulation barriers

### ◆ Wire Gauges and Tightening Torque

Select the appropriate wires and crimp terminals from [Table 3.3](#) through [Table 3.4](#).

**Note:** 1. Wire gauge recommendations based on drive continuous current ratings using 75°C 600 Vac vinyl-sheathed wire assuming ambient temperature within 40°C and wiring distance less than 100 m.

2. Terminals +1, +2, +3, and – are for connecting optional devices such as a DC reactor or braking unit. Do not connect other nonspecific devices to these terminals.

- Consider the amount of voltage drop when selecting wire gauges. Increase the wire gauge when the voltage drop is greater than 2% of motor rated voltage. Ensure the wire gauge is suitable for the terminal block. Use the following formula to calculate the amount of voltage drop:

$$\text{Line drop voltage (V)} = \sqrt{3} \times \text{wire resistance } (\Omega/\text{km}) \times \text{wire length (m)} \times \text{motor rated current (A)} \times 10^{-3}$$

- Refer to instruction manual TOBPC72060000 for braking unit or braking resistor unit wire gauges.

**NOTICE:** Do not connect a braking resistor to terminals +1 and -. Failure to comply may cause damage to the drive circuitry.

- Use terminal +1 and the negative terminal when connecting a regenerative converter, or a regen unit.
- [Refer to UL Standards Compliance on page 446](#) for information on UL compliance.

Yaskawa recommends using closed-loop crimp terminals on all drive models. UL/cUL approval requires the use of closed-loop crimp terminals when wiring the drive main circuit terminals on models CIMR-E□2A0110 to 2A0415 and 4A0058 to 4A1200. Use only the tools recommended by the terminal manufacturer for crimping. Refer to [Closed-Loop Crimp Terminal Size on page 450](#) for closed-loop crimp terminal recommendations.

The wire gauges listed in the following tables are Yaskawa recommendations. Refer to local codes for proper wire gauge selections.

### ■ Three-Phase 200 V Class

Table 3.3 Wire Gauge and Torque Specifications (Three-Phase 200 V Class)

Model CIMR-E□	Terminal	Recommended Gauge mm <sup>2</sup>	Applicable Gauge mm <sup>2</sup>	Screw Size	Tightening Torque N·m (lb.in.)
2A0004 2A0006 2A0008 2A0010	R/L1, S/L2, T/L3	2.5	2.5 to 6	M4	1.2 to 1.5 (10.6 to 13.3)
	U/T1, V/T2, W/T3	2.5	2.5 to 6		
	–, +1, +2	–	2.5 to 6		
	⊕	2.5 </>	2.5 to 6		
2A0012	R/L1, S/L2, T/L3	2.5	2.5 to 6	M4	1.2 to 1.5 (10.6 to 13.3)
	U/T1, V/T2, W/T3	2.5	2.5 to 6		
	–, +1, +2	–	2.5 to 6		
	⊕	2.5 </>	2.5 to 6		
2A0018	R/L1, S/L2, T/L3	2.5	2.5 to 6	M4	1.2 to 1.5 (10.6 to 13.3)
	U/T1, V/T2, W/T3	2.5	2.5 to 6		
	–, +1, +2	–	2.5 to 6		
	⊕	2.5 </>	2.5 to 6		

### 3.8 Main Circuit Wiring

Model CIMR-E□	Terminal	Recommended Gauge mm <sup>2</sup>	Applicable Gauge mm <sup>2</sup>	Screw Size	Tightening Torque N·m (lb.in.)
2A0021	R/L1, S/L2, T/L3	4	2.5 to 6	M4	1.2 to 1.5 (10.6 to 13.3)
	U/T1, V/T2, W/T3	2.5	2.5 to 6		
	-, +1, +2	-	4 to 6		
	⊕	4 <I>	4 to 6		
2A0030	R/L1, S/L2, T/L3	6	4 to 16	M4	2.1 to 2.3 (18.4 to 20.4)
	U/T1, V/T2, W/T3	6	4 to 16		
	-, +1, +2	-	6 to 16		
	⊕	6 <I>	6 to 10	M5	2 to 2.5 (17.7 to 22.1)
2A0040	R/L1, S/L2, T/L3	10	6 to 16	M4	2.1 to 2.3 (18.4 to 20.4)
	U/T1, V/T2, W/T3	10	6 to 16		
	-, +1, +2	-	16		
	⊕	10	6 to 10	M5	2 to 2.5 (17.7 to 22.1)
2A0056	R/L1, S/L2, T/L3	16	16 to 25	M6	5.4 to 6.0 (47.8 to 53.1)
	U/T1, V/T2, W/T3	16	16 to 25		
	-, +1, +2	-	16 to 25		
	⊕	16	10 to 16	M6	4 to 6 (35.4 to 53.1)
2A0069	R/L1, S/L2, T/L3	25	16 to 25	M8	9.9 to 11.0 (87.6 to 97.4)
	U/T1, V/T2, W/T3	16	16 to 25		
	-, +1, +2	-	25		
	⊕	16	16 to 25	M6	4 to 6 (35.4 to 53.1)
2A0081	R/L1, S/L2, T/L3	35	25 to 35	M8	9.9 to 11.0 (87.6 to 97.4)
	U/T1, V/T2, W/T3	25	25 to 35		
	-, +1, +2	-	25 to 35		
	⊕	16	16 to 25	M6	4 to 6 (35.4 to 53.1)
2A0110	R/L1, S/L2, T/L3	35	25 to 50	M8	9 to 11 (79.7 to 97.4)
	U/T1, V/T2, W/T3	35	25 to 50		
	-, +1	-	35 to 50		
	⊕	16	16 to 25		
2A0138	R/L1, S/L2, T/L3	50	35 to 70	M10	18 to 23 (159 to 204)
	U/T1, V/T2, W/T3	50	35 to 70		
	-, +1	-	50 to 70		
	⊕	25	25	M8	9 to 11 (79.7 to 97.4)
2A0169	R/L1, S/L2, T/L3	70	50 to 95	M10	18 to 23 (159 to 204)
	U/T1, V/T2, W/T3	70	50 to 95		
	-, +1	-	35 to 95		
	+3	-	50 to 95		
	⊕	35	25 to 35		
2A0211	R/L1, S/L2, T/L3	95	70 to 95	M10	18 to 23 (159 to 204)
	U/T1, V/T2, W/T3	95	70 to 95		
	-, +1	-	35 to 95		
	+3	-	50 to 95		
	⊕	50	25 to 50		
2A0250	R/L1, S/L2, T/L3	95 × 2P	95 to 150	M12	32 to 40 (283 to 354)
	U/T1, V/T2, W/T3	95 × 2P	95 to 150		
	-, +1	-	70 to 150		
	+3	-	35 to 150	M10	18 to 23 (159 to 204)
	⊕	95	95 to 150	M12	32 to 40 (283 to 354)
2A0312	R/L1, S/L2, T/L3	95 × 2P	95 to 150	M12	32 to 40 (283 to 354)
	U/T1, V/T2, W/T3	95 × 2P	95 to 150		
	-, +1	-	70 to 150		
	+3	-	70 to 150	M10	18 to 23 (159 to 204)
	⊕	95	95 to 150	M12	32 to 40 (283 to 354)

Model CIMR-E□	Terminal	Recommended Gauge mm <sup>2</sup>	Applicable Gauge mm <sup>2</sup>	Screw Size	Tightening Torque N·m (lb.in.)
2A0360	R/L1, S/L2, T/L3	240	95 to 300	M12	32 to 40 (283 to 354)
	U/T1, V/T2, W/T3	240	95 to 300		
	-, +1	-	125 to 300		
	+3	-	70 to 300	M10	18 to 23 (159 to 204)
	⊕	120	120 to 240	M12	32 to 40 (283 to 354)
2A0415	R/L1, S/L2, T/L3	120 × 2P	95 to 300	M12	32 to 40 (283 to 354)
	U/T1, V/T2, W/T3	300	95 to 300		
	-, +1	-	150 to 300		
	+3	-	70 to 300	M10	18 to 23 (159 to 204)
	⊕	120	120 to 240	M12	32 to 40 (283 to 354)

<1> When installing an EMC filter, additional measures must be taken to comply with IEC61800-5-1. Refer to [EMC Filter Installation on page 441](#).

### ■ Three-Phase 400 V Class

Table 3.4 Wire Gauge and Torque Specifications (Three-Phase 400 V Class)

Model CIMR-E□	Terminal	Recommended Gauge mm <sup>2</sup>	Applicable Gauge mm <sup>2</sup>	Screw Size	Tightening Torque N·m (lb.in.)
4A0002 4A0004	R/L1, S/L2, T/L3	2.5	2.5 to 6	M4	1.2 to 1.5 (10.6 to 13.3)
	U/T1, V/T2, W/T3	2.5	2.5 to 6		
	-, +1, +2	-	2.5 to 6		
	⊕	2.5	2.5 to 4		
4A0005 4A0007 4A0009	R/L1, S/L2, T/L3	2.5	2.5 to 6	M4	1.2 to 1.5 (10.6 to 13.3)
	U/T1, V/T2, W/T3	2.5	2.5 to 6		
	-, +1, +2	-	2.5 to 6		
	⊕	2.5	2.5 to 6		
4A0011	R/L1, S/L2, T/L3	2.5	2.5 to 6	M4	1.2 to 1.5 (10.6 to 13.3)
	U/T1, V/T2, W/T3	2.5	2.5 to 6		
	-, +1, +2	-	2.5 to 6		
	⊕	2.5	2.5 to 6		
4A0018	R/L1, S/L2, T/L3	2.5	2.5 to 16	M4	2.1 to 2.3 (18.4 to 20.4)
	U/T1, V/T2, W/T3	2.5	2.5 to 16		
	-, +1, +2	-	4 to 16	M5	2 to 2.5 (17.7 to 22.1)
	⊕	2.5	2.5 to 6		
4A0023	R/L1, S/L2, T/L3	4	2.5 to 16	M4	2.1 to 2.3 (18.4 to 20.4)
	U/T1, V/T2, W/T3	4	2.5 to 16		
	-, +1, +2	-	4 to 16		
	⊕	4	4 to 6	M5	2 to 2.5 (17.7 to 22.1)
4A0031	R/L1, S/L2, T/L3	6	6 to 16	M5	2.7 to 3.0 (23.9 to 26.6)
	U/T1, V/T2, W/T3	6	6 to 16		
	-, +1, +2	-	6 to 16		
	⊕	6	6 to 10	M6	4 to 6 (35.4 to 53.1)
4A0038	R/L1, S/L2, T/L3	10	10 to 16	M5	2.7 to 3.0 (23.9 to 26.6)
	U/T1, V/T2, W/T3	6	6 to 16		
	-, +1, +2	-	6 to 16		
	⊕	10	6 to 16	M6	4 to 6 (35.4 to 53.1)
4A0044	R/L1, S/L2, T/L3	16	16 to 25	M6	5.4 to 6.0 (47.8 to 53.1)
	U/T1, V/T2, W/T3	16	16 to 25		
	-, +1, +2	-	16 to 25		
	⊕	16	10 to 16	M6	4 to 6 (35.4 to 53.1)
4A0058	R/L1, S/L2, T/L3	16	10 to 16	M8	9 to 11 (79.7 to 97.4)
	U/T1, V/T2, W/T3	16	10 to 16		
	-, +1	-	16 to 35		
	⊕	16	10 to 16		

### 3.8 Main Circuit Wiring

Model CIMR-E□	Terminal	Recommended Gauge mm <sup>2</sup>	Applicable Gauge mm <sup>2</sup>	Screw Size	Tightening Torque N·m (lb.in.)
4A0072	R/L1, S/L2, T/L3	16	16 to 25	M8	9 to 11 (79.7 to 97.4)
	U/T1, V/T2, W/T3	25	16 to 25		
	-, +1	-	25 to 35		
	⊕	16	16 to 25		
4A0088	R/L1, S/L2, T/L3	25	16 to 50	M8	9 to 11 (79.7 to 97.4)
	U/T1, V/T2, W/T3	25	25 to 50		
	-, +1	-	25 to 50		
	+3	-	16 to 50		
	⊕	16	16 to 25		
4A0103	R/L1, S/L2, T/L3	35	25 to 50	M8	9 to 11 (79.7 to 97.4)
	U/T1, V/T2, W/T3	35	25 to 50		
	-, +1	-	25 to 50		
	+3	-	25 to 50		
	⊕	16	16 to 25		
4A0139	R/L1, S/L2, T/L3	50	35 to 95	M10	18 to 23 (159 to 204)
	U/T1, V/T2, W/T3	50	35 to 95		
	-, +1	-	50 to 95		
	+3	-	25 to 95		
	⊕	25	25		
4A0165	R/L1, S/L2, T/L3	70	50 to 95	M10	18 to 23 (159 to 204)
	U/T1, V/T2, W/T3	70	70 to 95		
	-, +1	-	35 to 95		
	+3	-	50 to 95		
	⊕	35	25 to 35		
4A0208	R/L1, S/L2, T/L3	95	35 to 95	M10	18 to 23 (159 to 204)
	U/T1, V/T2, W/T3	95	35 to 95		
	-, +1	-	35 to 150		
	+3	-	25 to 70		
	⊕	50	50 to 150		
4A0250	R/L1, S/L2, T/L3	120	95 to 300	M10	18 to 23 (159 to 204)
	U/T1, V/T2, W/T3	120	95 to 300		
	-, +1	-	70 to 300		
	+3	-	35 to 300		
	⊕	70	70 to 240		
4A0296	R/L1, S/L2, T/L3	185	95 to 300	M12	32 to 40 (283 to 354)
	U/T1, V/T2, W/T3	185	95 to 300		
	-, +1	-	70 to 300	M10	18 to 23 (159 to 204)
	+3	-	35 to 300		
	⊕	95	95 to 240	M12	32 to 40 (283 to 354)
4A0362	R/L1, S/L2, T/L3	240	95 to 300	M12	32 to 40 (283 to 354)
	U/T1, V/T2, W/T3	240	95 to 300		
	-, +1	-	95 to 300	M10	18 to 23 (159 to 204)
	+3	-	70 to 300		
	⊕	120	120 to 240	M12	32 to 40 (283 to 354)
4A0414 <D>	R/L1, S/L2, T/L3	95 × 2P	95 to 150	M12	32 to 40 (283 to 354)
	U/T1, V/T2, W/T3	95 × 2P	95 to 150		
	-, +1	-	70 to 150		
	+3	-	70 to 150		
	⊕	95	35 to 95		
4A0515 <D>	R/L1, S/L2, T/L3	120 × 2P	95 to 150	M12	32 to 40 (283 to 354)
	U/T1, V/T2, W/T3	150 × 2P	95 to 150		
	-, +1	-	70 to 150		
	+3	-	70 to 150		
	⊕	150	50 to 150		

Model CIMR-E□	Terminal	Recommended Gauge mm <sup>2</sup>	Applicable Gauge mm <sup>2</sup>	Screw Size	Tightening Torque N·m (lb.in.)
4A0675 <1>	R/L1, S/L2, T/L3	95 × 4P	95 to 150	M12	32 to 40 (283 to 354)
	U/T1, V/T2, W/T3	95 × 4P	95 to 150		
	-, +1	–	70 to 150		
	+3	–	70 to 150		
	⊕	95 × 2P	60 to 150		
4A0930 <1>	R/L1, S/L2, T/L3, R1/L11, S1/L21, T1/L31	120 × 4P	95 to 150	M12	32 to 40 (283 to 354)
	U/T1, V/T2, W/T3	120 × 4P	95 to 150		
	-, +1	–	95 to 150		
	+3	–	95 to 150		
	⊕	120 × 2P	70 to 120		
4A1200 <1>	R/L1, S/L2, T/L3, R1/L11, S1/L21, T1/L31	(95 × 4P) × 2	95 to 150	M12	32 to 40 (283 to 354)
	U/T1, V/T2, W/T3	(95 × 4P) × 2	95 to 150		
	-, +1	–	120 to 150		
	+3	–	95 to 150		
	⊕	95 × 4P	95 to 120		

<1> When using model CIMR-E□4A0414 to 4A1200, additional measures must be taken in order to comply with IEC61800-5-1. Refer to **EMC Filter Installation on page 441**.

## ◆ Main Circuit Terminal and Motor Wiring

This section outlines the various steps, precautions, and checkpoints for wiring the main circuit terminals and motor terminals.

**NOTICE:** When connecting the motor to the drive output terminals U/T1, V/T2, and W/T3, the phase order for the drive and motor should match. Failure to comply with proper wiring practices may cause the motor to run in reverse if the phase order is backward.

**NOTICE:** Do not connect phase-advancing capacitors or LC/RC noise filters to the output circuits. Failure to comply could result in damage to the drive, phase-advancing capacitors, LC/RC noise filters or ground fault circuit interrupters.

**NOTICE:** Do not connect the AC power line to the output terminals of the drive. Failure to comply could result in death or serious injury by fire as a result of drive damage from line voltage application to output terminals.

## ■ Cable Length Between Drive and Motor

Voltage drop along the motor cable may cause reduced motor torque when the wiring between the drive and the motor is too long, especially at low frequency output. This can also be a problem when motors are connected in parallel with a fairly long motor cable. Drive output current will increase as the leakage current from the cable increases. An increase in leakage current may trigger an overcurrent situation and weaken the accuracy of the current detection.

Adjust the drive carrier frequency according to **Table 3.5**. If the motor wiring distance exceeds 100 m because of the system configuration, reduce the ground currents. **Refer to C6-02: Carrier Frequency Selection on page 163**.

**Table 3.5 Cable Length Between Drive and Motor**

Cable Length	50 m or less	100 m or less	Greater than 100 m
Carrier Frequency	15 kHz or less	5 kHz or less	2 kHz or less

**Note:** When setting carrier frequency in a drive running multiple motors, calculate the cable length as the total distance of wiring to all motors that are connected.

## 3.8 Main Circuit Wiring

### ■ Ground Wiring

Follow the precautions to wire the ground for one drive or a series of drives.

**WARNING! Electrical Shock Hazard.** Make sure the protective earthing conductor complies with technical standards and local safety regulations. Because the leakage current exceeds 3.5 mA in models CIMR-E□4A0414 and larger, IEC 61800-5-1 states that either the power supply must be automatically disconnected in case of discontinuity of the protective earthing conductor or a protective earthing conductor with a cross-section of at least 10 mm<sup>2</sup> (Cu) or 16 mm<sup>2</sup> (Al) must be used. Failure to comply may result in death or serious injury.

**WARNING! Electrical Shock Hazard.** Always use a ground wire that complies with technical standards on electrical equipment and minimize the length of the ground wire. Improper equipment grounding may cause dangerous electrical potentials on equipment chassis, which could result in death or serious injury.

**WARNING! Electrical Shock Hazard.** Be sure to ground the drive ground terminal. Improper equipment grounding could result in death or serious injury by contacting ungrounded electrical equipment.

**NOTICE:** Do not share the ground wire with other devices such as welding machines or large-current electrical equipment. Improper equipment grounding could result in drive or equipment malfunction due to electrical interference.

**NOTICE:** When using more than one drive, ground multiple drives according to instructions. Improper equipment grounding could result in abnormal operation of drive or equipment.

Refer to [Figure 3.20](#) when using multiple drives. Do not loop the ground wire.

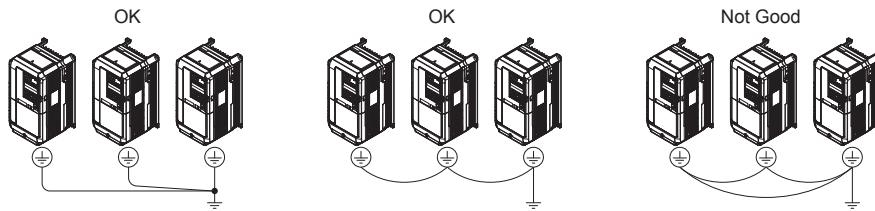


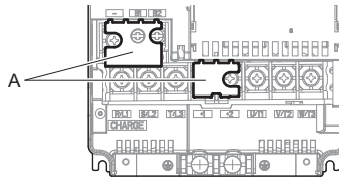
Figure 3.20 Multiple Drive Wiring

### ■ Wiring the Main Circuit Terminal

**WARNING! Electrical Shock Hazard.** Shut off the power supply to the drive before wiring the main circuit terminals. Failure to comply may result in death or serious injury.

Wire the main circuit terminals after the terminal board has been properly grounded.

Models CIMR-E□2A0004 through 0081 and 4A0002 through 0044 have a cover placed over the DC bus and braking circuit terminals prior to shipment to help prevent miswiring. Cut away covers as needed for terminals using wire cutters.



A – Protecting Cover

Figure 3.21 Protecting Cover to Prevent Miswiring (CIMR-E□2A0056)

### ■ Main Circuit Configurations

Refer to [Main Circuit Configurations on page 61](#) when wiring terminals on the drive's main power circuit.

## 3.9 Control Circuit Wiring

### ◆ Control Circuit Connection Diagram

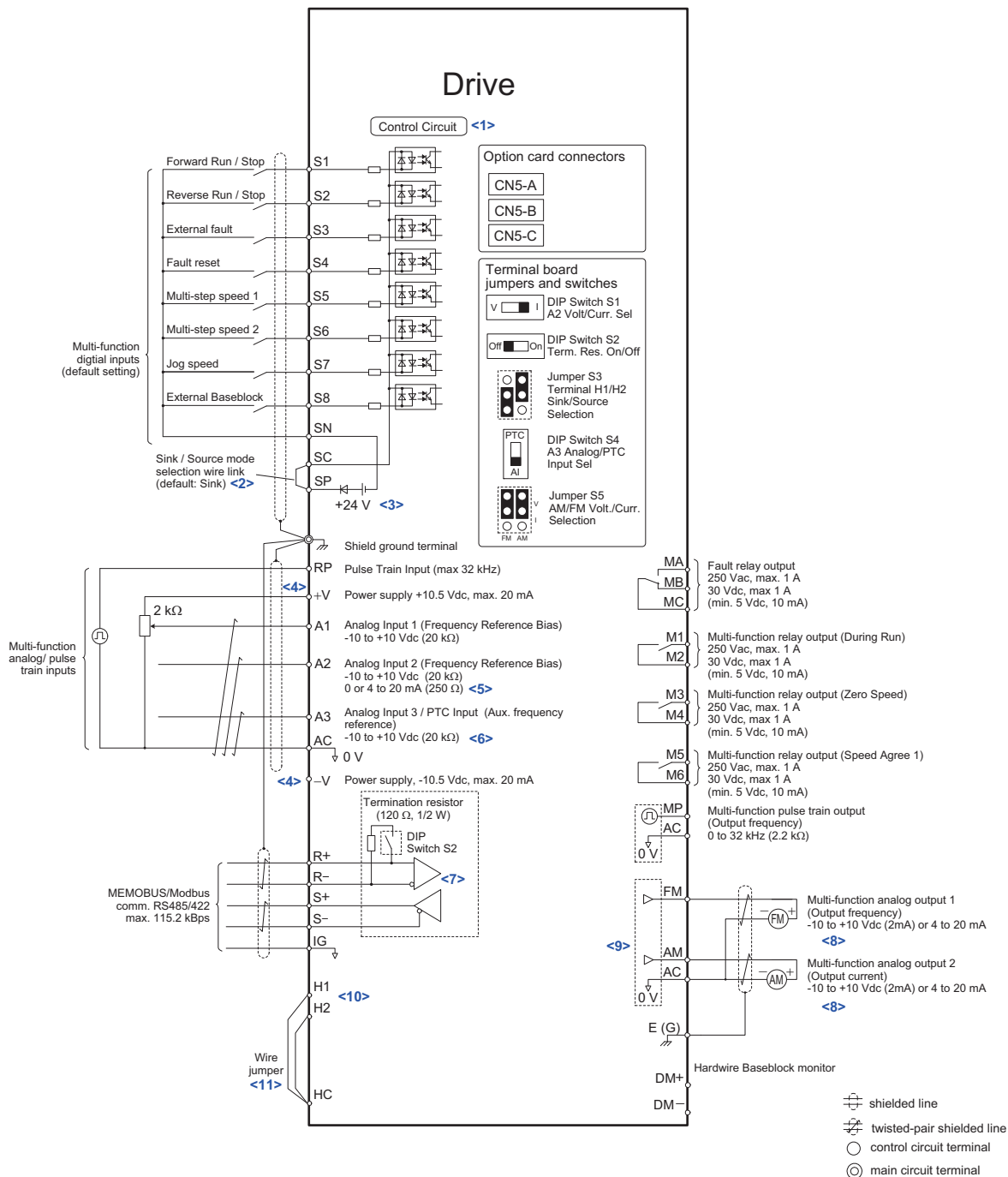


Figure 3.22 Control Circuit Connection Diagram

- <1> Supplying power to the control circuit separately from the main circuit requires 24 V power supply (option).
- <2> This figure shows an example of a sequence input to S1 through S8 using a non-powered relay or an NPN transistor. Install the wire link between terminals SC-SP for Sink mode and SC-SN for Source mode. Leave it out for external power supply. Never short terminals SP and SN as doing so will damage the drive.
- <3> The maximum current supplied by this voltage source is 150mA.
- <4> The maximum output current capacity for the +V and -V terminals on the control circuit is 20 mA. Never short terminals +V, -V, and AC, as this can cause erroneous operation or damage the drive.
- <5> Set DIP switch S1 to select between a voltage or current input signal to terminal A2. The default setting is for current input.
- <6> Set DIP switch S4 to select between analog or PTC input for terminal A3.
- <7> Enable the termination resistor in the last drive in a MEMOBUS network by setting DIP switch S2 to the ON position.
- <8> Monitor outputs work with devices such as analog frequency meters, ammeters, voltmeters, and wattmeters. They are not intended for use as a feedback-type of signal.

### 3.9 Control Circuit Wiring

- <9> Use jumper S5 to selection between voltage or current output signals at terminal AM and FM. Set parameters H4-07 and H4-08 accordingly.
- <10> Use jumper S3 to select between Sink Mode, Source Mode or External Power supply for Hardwire Baseblock Inputs.
- <11> Disconnect the wire jumper between H1-HC, H2-HC when utilizing the Hardwire Baseblock Inputs.

#### ◆ Control Circuit Terminal Block Functions

Drive parameters determine which functions apply to the multi-function digital inputs (S1 to S8), multi-function digital outputs (M1 to M6), multi-function analog inputs (A1 to A3), and multi-function analog monitor output (FM, AM). The default setting is listed next to each terminal in [Figure 3.22](#).

**WARNING! Sudden Movement Hazard.** Always check the operation and wiring of control circuits after being wired. Operating a drive with untested control circuits could result in death or serious injury.

**WARNING! Confirm the drive I/O signals and external sequence before starting test run.** Setting parameter A1-06 may change the I/O terminal function automatically from the factory setting. Refer to [Application Selection on page 111](#). Failure to comply may result in death or serious injury.

#### ■ Input Terminals

[Table 3.6](#) lists the input terminals on the drive. Text in parenthesis indicates the default setting for each multi-function input.

**Table 3.6 Control Circuit Input Terminals**

Type	No.	Terminal Name (Function)	Function (Signal Level) Default Setting	Page
Multi-Function Digital Inputs	S1	Multi-function input 1 (Closed: Forward run, Open: Stop)	Photocoupler 24 Vdc, 8 mA	373
	S2	Multi-function input 2 (Closed: Reverse run, Open: Stop)		
	S3	Multi-function input 3 (External fault, N.O.)		
	S4	Multi-function input 4 (Fault reset)		
	S5	Multi-function input 5 (Multi-step speed reference 1)		
	S6	Multi-function input 6 (Multi-step speed reference 2)		
	S7	Multi-function input 7 (Jog reference)		
	S8	Multi-function input 8 (External baseblock)		
	SC	Multi-function input common	Multi-function input common	
	SP	Digital input power supply +24 Vdc	24 Vdc power supply for digital inputs, 150 mA max.	85
SN	Digital input power supply 0 V	Never short terminals SP and SN as doing so will damage the drive.		
Analog Inputs / Pulse Train Input	RP	Multi-function pulse train input (Frequency reference)	Input frequency range: 0 to 32 kHz Signal Duty Cycle: 30 to 70% High level: 3.5 to 13.2 Vdc, low level: 0.0 to 0.8 Vdc Input impedance: 3 kΩ	132 206
	+V	Power supply for analog inputs	10.5 Vdc (max allowable current 20 mA)	131
	-V	Power supply for analog inputs	-10.5 Vdc (max allowable current 20 mA)	-
	A1	Multi-function analog input 1 (Frequency reference bias)	-10 to 10 Vdc, 0 to 10 Vdc (input impedance: 20 kΩ)	131 199
	A2	Multi-function analog input 2 (Frequency reference bias)	-10 to 10 Vdc, 0 to 10 Vdc (input impedance: 20 kΩ) 4 to 20 mA, 0 to 20 mA (input impedance: 250 Ω) Voltage or current input must be selected by DIP switch S1 and H3-09	131 132 201
	A3	Multi-function analog input 3 (auxiliary frequency reference) / PTC Input	-10 to 10 Vdc, 0 to 10 Vdc (input impedance: 20 kΩ) Use DIP switch S4 on the terminal board to selection between analog or PTC input.	131
	AC	Frequency reference common	0 V	131
	H1	Hardwire Baseblock inputs 1	24 Vdc, 8 mA One or both open: Output disabled Both closed: Normal operation Internal impedance: 3.3 kΩ Off time of at least 1 ms Disconnect the wire jumpers shorting terminals H1, H2, and HC to use the Hardwire Baseblock inputs. Set the S3 jumper to select between sinking, sourcing mode, and the power supply as explained for multi-function input terminals in <a href="#">Sinking/Sourcing Mode Selection for Hardwire Baseblock Inputs on page 85</a> .	-
	H2	Hardwire Baseblock inputs 2		
	HC	Hardwire Baseblock common		
E (G)	Ground for shielded lines and option cards	-	-	



## Output Terminals

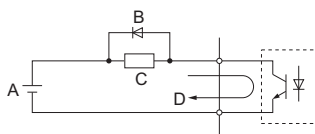
**Table 3.7** lists the output terminals on the drive. Text in parenthesis indicates the default setting for each multi-function output.

**Table 3.7 Control Circuit Output Terminals**

Type	No.	Terminal Name (Function)	Function (Signal Level) Default Setting	Page
Fault Relay Output	MA	N.O.	30 Vdc, 10 mA to 1 A; 250 Vac, 10 mA to 1 A Minimum load: 5 Vdc, 10 mA	190
	MB	N.C. output		
	MC	Fault output common		
Multi-Function Digital Output <1>	M1	Multi-function digital output (During run)	30 Vdc, 10 mA to 1 A; 250 Vac, 10 mA to 1 A Minimum load: 5 Vdc, 10 mA <2>	190
	M2			
	M3	Multi-function digital output (Zero Speed)		
	M4			
	M5	Multi-function digital output (Speed Agree 1)		
	M6			
Monitor Output	MP	Pulse train output (Output frequency)	32 kHz (max)	206
	FM	Analog monitor output 1 (Output frequency)	-10 to +10 Vdc, 0 to +10 Vdc, or 4-20 mA	205
	AM	Analog monitor output 2 (Output current)	Use jumper S5 on the terminal board to select between voltage or current output signals.	
	DM+	Hardwire Baseblock monitor output	Outputs status of Hardwire Baseblock function. Closed when both Hardwire Baseblock channels are closed. Up to +48 Vdc 50 mA	-
	DM-			
	AC	Monitor common	0 V	-

<1> Refrain from assigning functions to digital outputs that involve frequent switching, as doing so may shorten relay performance life. Switching life is estimated at 200,000 times (assumes 1 A, resistive load).

<2> Connect a flywheel diode as shown in the **Figure 3.23** when driving a reactive load such as a relay coil. Make sure the diode rating is greater than the circuit voltage.



**A** – External power, 48 V max.

**B** – Suppression diode

**C** – Coil

**D** – 50 mA or less

**Figure 3.23 Connecting a Suppression Diode**

## Serial Communication Terminals

**Table 3.8 Control Circuit Terminals: Serial Communications**

Type	No.	Signal Name	Function (Signal Level)
MEMOBUS/Modbus Communication <1>	R+	Communications input (+)	MEMOBUS/Modbus communication: Use a RS-485 or RS-422 cable to connect the drive. RS-485/422 MEMOBUS/Modbus communication protocol 115.2 kbps (max.)
	R-	Communications input (-)	
	S+	Communications output (+)	
	S-	Communications output (-)	
	IG	Shield ground	

<1> Enable the termination resistor in the last drive in a MEMOBUS network by setting DIP switch S2 to the ON position. For more information on the termination resistor, see **Control I/O Connections on page 85**.

#### ◆ Terminal Configuration

Control circuit terminals should be arranged as shown in [Figure 3.24](#).

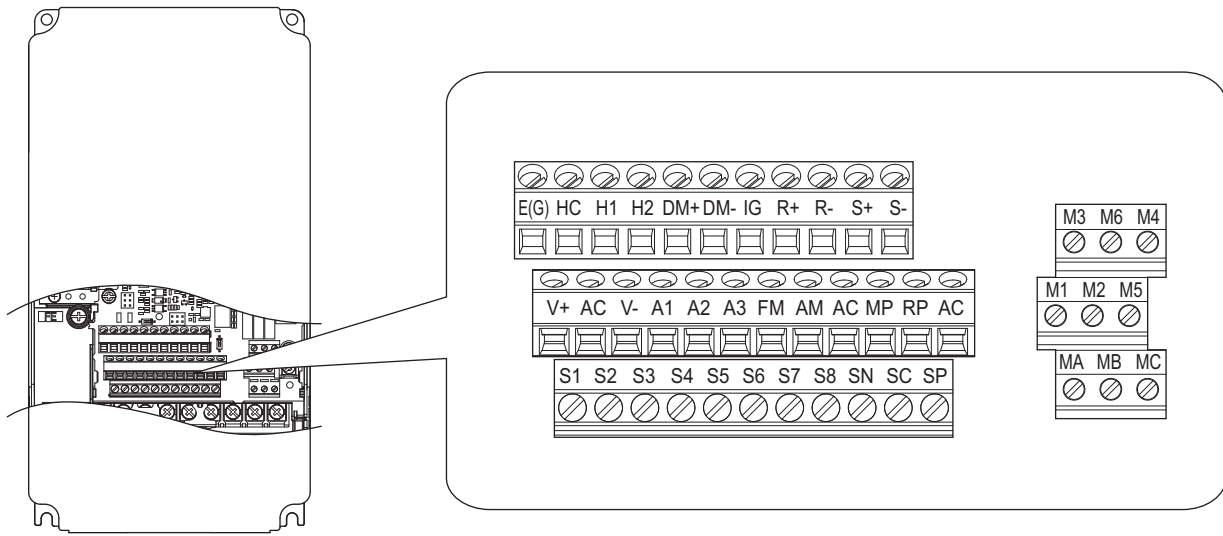


Figure 3.24 Control Circuit Terminal Arrangement

#### ■ Wire Size and Torque Specifications

Select appropriate wire type and gauges from [Table 3.9](#). For simpler and more reliable wiring, use crimp ferrules on the wire ends. Refer to [Table 3.10](#) for ferrule terminal types and sizes.

Table 3.9 Wire Gauges and Torque Specifications

Terminal	Screw Size	Tightening Torque N·m (lb.in.)	Bare Wire Terminal		Ferrule-Type Terminal		Wire Type
			Applicable wire size mm <sup>2</sup> (AWG)	Recommended wire size mm <sup>2</sup> (AWG)	Applicable wire size mm <sup>2</sup> (AWG)	Recommended wire size mm <sup>2</sup> (AWG)	
S1-S8, SC, SP, SN, RP, +V, -V, A1, A2, A3, AC, M1-M6, MA, MB, MC, MP, AM, FM, AC, S+, S-, R+, R-, IG, HC, H1, H2, DM+, DM-	M2	0.22 to 0.25 (1.9 to 2.2)	Stranded wire: 0.2 to 1.0 (24 to 16) Solid wire: 0.2 to 1.5 (24 to 16)	0.75 (18)	0.25 to 0.5 (24 to 20)	0.5 (20)	Shielded line, etc.

#### ■ Ferrule-Type Wire Terminals

Yaskawa recommends using CRIMPFOX 6, a crimping tool manufactured by PHOENIX CONTACT, to prepare wire ends with insulated sleeves before connecting to the drive. See [Table 3.10](#) for dimensions.

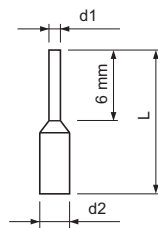


Figure 3.25 Ferrule Dimensions

Table 3.10 Ferrule Terminal Types and Sizes

Size mm <sup>2</sup> (AWG)	Type	L (mm)	d1 (mm)	d2 (mm)	Manufacturer
0.25 (24)	AI 0.25-6YE	10.5	0.8	2	PHOENIX CONTACT
0.34 (22)	AI 0.34-6TQ	10.5	0.8	2	
0.5 (20)	AI 0.5-6WH	14	1.1	2.5	

## ◆ Wiring the Control Circuit Terminal

This section describes the proper procedures and preparations for wiring the control terminals.

**WARNING!** *Electrical Shock Hazard. Do not remove covers or touch the circuit boards while the power is on. Failure to comply could result in death or serious injury.*

**NOTICE:** *Separate control circuit wiring from main circuit wiring (terminals R/L1, S/L2, T/L3, R1/L11, S1/L21, T1/L31, B1, B2, U/T1, V/T2, W/T3, -, +1, +2, +3) and other high-power lines. Improper wiring practices could result in drive malfunction due to electrical interference.*

**NOTICE:** *Separate wiring for digital output terminals MA, MB, MC and M1 to M6 from wiring to other control circuit lines. Improper wiring practices could result in drive or equipment malfunction or nuisance trips.*

**NOTICE:** *Use a class 2 power supply (UL standard) when connecting to the control terminals. Improper application of peripheral devices could result in drive performance degradation due to improper power supply.*

**NOTICE:** *Insulate shields with tape or shrink tubing to prevent contact with other signal lines and equipment. Improper wiring practices could result in drive or equipment malfunction due to short circuit.*

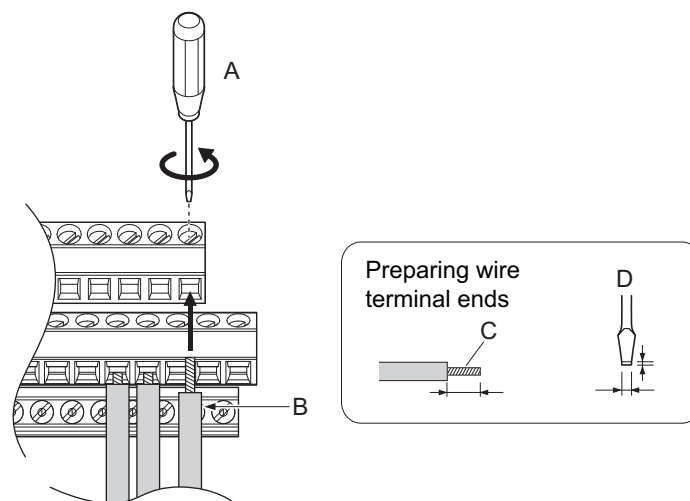
**NOTICE:** *Connect the shield of shielded cable to the appropriate ground terminal. Improper equipment grounding could result in drive or equipment malfunction or nuisance trips.*

Wire the control circuit only after terminals have been properly grounded and main circuit wiring is complete. Refer to [Figure 3.25](#) for details. Prepare the ends of the control circuit wiring as shown in [Figure 3.28](#). Refer to [Wire Size and Torque Specifications on page 82](#).

**NOTICE:** *Do not tighten screws beyond the specified tightening torque. Failure to comply may result in erroneous operation, damage the terminal block, or cause a fire.*

**NOTICE:** *Use shielded twisted-pair cables as indicated to prevent operating faults. Improper wiring practices could result in drive or equipment malfunction due to electrical interference.*

Connect control wires as shown in [Figure 3.26](#) and [Figure 3.27](#):



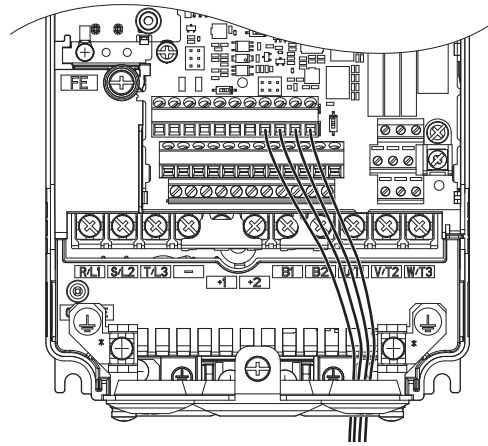
A – Loosen screw to insert wire.

B – Single wire or stranded wire

C – Avoid fraying wire strands when stripping insulation from wire. Strip length 5.5 mm.

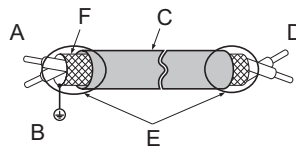
D – Blade depth of 0.4 mm or less  
Blade width of 2.5 mm or less

Figure 3.26 Terminal Board Wiring Guide



**Figure 3.27 Terminal Board Wiring**

When setting the frequency by analog reference from an external potentiometer, use shielded twisted-pair wires (treating wire ends as shown in [Figure 3.28](#) and connect the shield to the ground terminal of the drive.



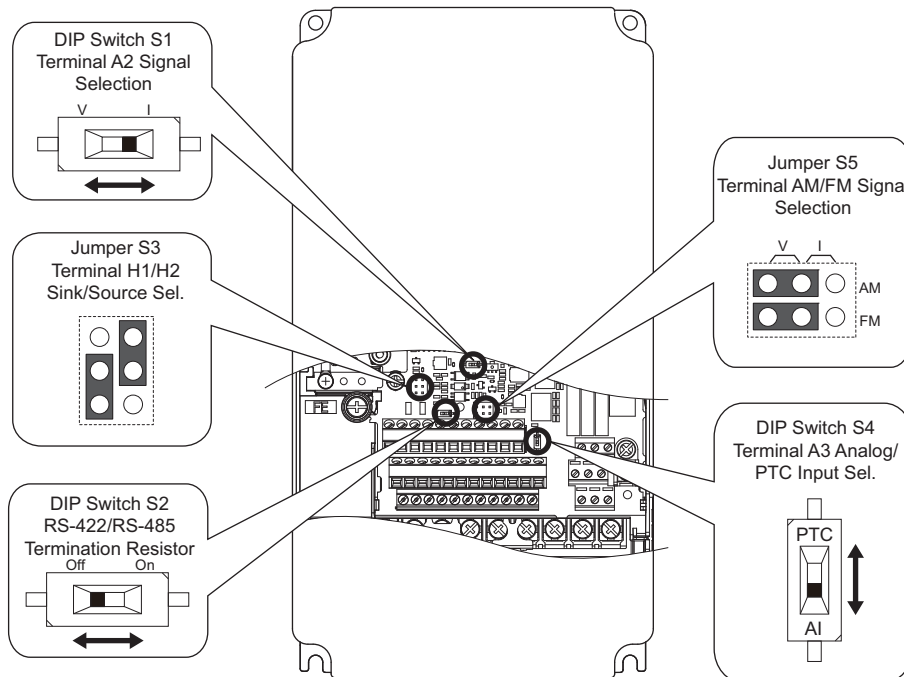
- |  |   |
|--|---|
| <b>A – Drive side</b>                                  | <b>D – Control device side</b>                |
| <b>B – Connect shield to ground terminal of drive.</b> | <b>E – Shield sheath (insulate with tape)</b> |
| <b>C – Insulation</b>                                  | <b>F – Shield</b>                             |

**Figure 3.28 Preparing the Ends of Shielded Cables**

**NOTICE:** The signal lines between the drive and the operator station or peripheral equipment should not exceed 50 meters when using an analog signal from a remote source to supply the frequency reference. Failure to comply could result in poor system performance.

#### ◆ Switches and Jumpers on the Terminal Board

The terminal board is equipped with several switches used to adapt the drive I/Os to the external control signals. [Figure 3.29](#) shows the location of these switches. Refer to [Control I/O Connections on page 85](#) for setting instructions.



**Figure 3.29 Locations of Jumpers and Switches on the Terminal Board**

## 3.10 Control I/O Connections

### ◆ Sinking/Sourcing Mode Selection for Hardwire Baseblock Inputs

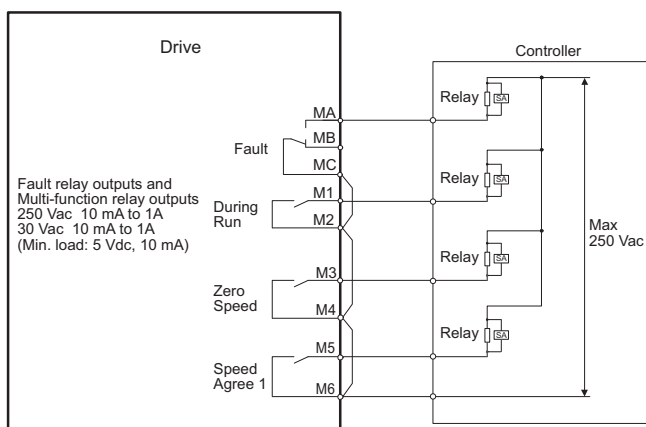
Use jumper S3 on the terminal board to select between Sink mode, Source mode or external power supply for the HardWire Baseblock inputs H1 and H2 as shown in Table 3.15 (Default: Source mode, internal power supply.) Refer to *Switches and Jumpers on the Terminal Board on page 84* for locating jumper S3.

**Table 3.11 Hardwire Baseblock Input Sink / Source / External Power Supply Selection**

	Drive Internal Power Supply	External 24 Vdc Power Supply
Sinking Mode		
Sourcing Mode		

### ◆ Using the Contact Outputs

The example below illustrates the use of multi-function digital outputs and the fault relay. Refer to *Figure 3.1* for standard connection diagram.



**Figure 3.30 Contact Outputs**

◆ Using the Pulse Train Output

The pulse train output terminal MP can either supply power but can also be used with external power supply. Peripheral devices should be connected in accordance with the specifications listed below. Failure to do so can cause unexpected drive operation, and can damage the drive or connected circuits.

■ Using Power from the Pulse Output Terminal (Source Mode)

The high voltage level of the pulse output terminal depends on the load impedance.

Load Impedance $R_L$ (k $\Omega$ )	Output Voltage $V_{MP}$ (V) (insulated)
1.5 k $\Omega$	5 V
4 k $\Omega$	8 V
10 k $\Omega$	10 V

**Note:** The load resistance needed in order to get a certain high level voltage  $V_{MP}$  can be calculated by:  $R_L = V_{MP} \cdot 2 / (12 - V_{MP})$

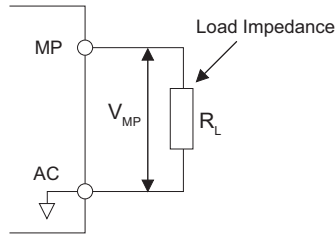


Figure 3.31 Pulse Output Connection Using Internal Voltage Supply

■ Using External Power Supply (Sink Mode)

The high voltage level of the pulse output signal depends on the external voltage applied. The voltage must be between 12 and 15 Vdc. The load resistance must be adjusted so that the current is lower than 16 mA.

External Power Supply (V)	Load Impedance (k $\Omega$ )
12 to 15 Vdc $\pm$ 10%	1.0 k $\Omega$ or higher

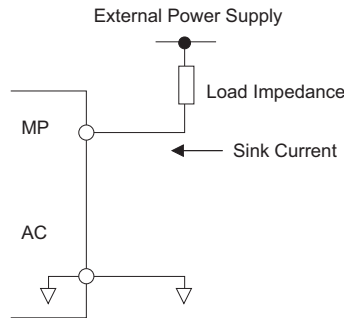


Figure 3.32 Pulse Output Connection Using External Voltage Supply

◆ Terminal A2 Input Signal Selection

Terminal A2 can be used to input either a voltage or a current signal. Select the signal type using switch S1 as explained in [Table 3.18](#). Set parameter H3-09 accordingly as shown in [Table 3.19](#). Refer to [Switches and Jumpers on the Terminal Board on page 84](#) for locating switch S1.

**Note:** If terminals A1 and A2 are both set for frequency bias (H3-02 = 0 and H3-10 = 0), both input values will be combined to create the frequency reference.

Table 3.12 DIP Switch S1 Settings

Setting	Description
V (left position)	Voltage input (-10 to +10 V)
I (right position) (default)	Current input (4 to 20 mA or 0 to 20 mA): default setting

Table 3.13 Parameter H3-09 Details

No.	Parameter Name	Description	Setting Range	Default Setting
H3-09	Terminal A2 signal level selection	Selects the signal level for terminal A2. 0: 0 to 10 Vdc 1: -10 to 10 Vdc 2: 4 to 20 mA 3: 0 to 20 mA	0 to 3	2

◆ Terminal A3 Analog/PTC Input Selection

Terminal A3 can be configured either as multi-function analog input or as PTC input for motor thermal overload protection. Use switch S4 to select the input function as described in [Table 3.14](#). Refer to [Switches and Jumpers on the Terminal Board on page 84](#) for locating switch S4.

Table 3.14 DIP Switch S4 Settings

Setting	Description
AI (lower position) (default)	Analog input for the function selected in parameter H3-06
PTC (upper position)	PTC input. Parameter H3-06 must be set to E (PTC input)

◆ Terminal AM/FM Signal Selection

The signal type for terminals AM and FM can be set to either voltage or current output using jumper S5 on the terminal board as explained in [Table 3.15](#). When changing the setting of jumper S5, parameters H4-07 and H4-08 must be set accordingly. The default selection is voltage output for both terminals. Refer to [Switches and Jumpers on the Terminal Board on page 84](#) for locating jumper S5.

Table 3.15 Jumper S5 Settings

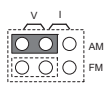
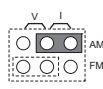
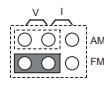
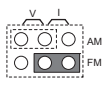
	Voltage Output	Current Output
Terminal AM		
Terminal FM		

Table 3.16 Parameter H4-07, H4-08 Details

No.	Parameter Name	Description	Setting Range	Default Setting
H4-07	Terminal AM signal level selection	0: 0 to 10 Vdc	0 to 2	0
H4-08	Terminal FM signal level selection	1: -10 to 10 Vdc 2: 4 to 20 mA		

◆ MEMOBUS/Modbus Termination

This drive is equipped with a built in termination resistor for the RS-422/RS-485 communication port. DIP switch S2 enables or disabled the termination resistor as shown in [Table 3.17](#). The OFF position is the default. The termination resistor should be placed to the ON position when the drive is the last in a series of slave drives. Refer to [Switches and Jumpers on the Terminal Board on page 84](#) for locating switch S2.

Table 3.17 MEMOBUS/Modbus Switch Settings

S2 Position	Description
ON	Internal termination resistor ON
OFF	Internal termination resistor OFF (default setting)

**Note:** Refer to [MEMOBUS/Modbus Communications on page 411](#) for details on MEMOBUS/Modbus.

## 3.11 Terminal A2 Analog Input Signal Selection

### ◆ Terminal A2 Input Signal Selection

Terminal A2 can be used to input either a voltage or a current signal.

When using input A2 as a voltage input, set DIP switch S1 to “V” (left position) and set parameter H3-09 to 0 (0 to 10 Vdc) or to 1 (-10 to 10 Vdc).

To use current input at terminal A2, set the DIP switch S1 to “I” (default setting) and H3-09 = 2 or 3 (4 to 20 mA or 0 to 20 mA).

To set the DIP switch on the terminal board, use an appropriate sized tool with a tip of approximately 0.8 mm in width.

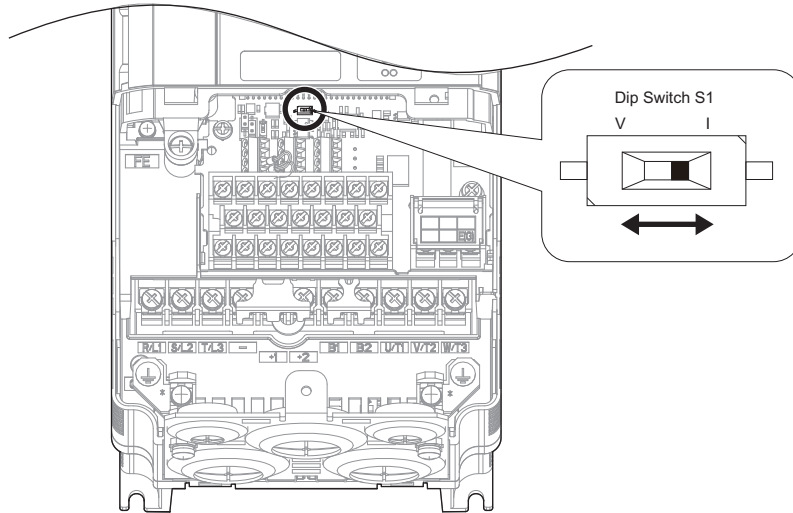


Figure 3.33 DIP Switch S1

**Note:** If terminals A1 and A2 are both set for frequency bias (H3-02 = 0 and H3-10 = 0), both input values will be combined to create the frequency reference.

Table 3.18 DIP Switch S1 Settings

Setting	Description
V (left position)	Voltage input (-10 to +10 V)
I (right position) (default)	Current input (4 to 20 mA or 0 to 20 mA): default setting

Table 3.19 Parameter H3-09 Details

No.	Parameter Name	Description	Setting Range	Default Setting
H3-09	Terminal A2 signal level selection	Selects the signal level for terminal A2. 0: 0 to 10 Vdc 1: -10 to 10 Vdc 2: 4 to 20 mA 3: 0 to 20 mA	0 to 3	2



## 3.12 Connect to a PC

This drive is equipped with a USB port (type-B).

The drive can connect to the USB port of a PC using a USB 2.0, AB type cable (sold separately). DriveWizard Plus can then be used to monitor drive performance and manage parameter settings. Contact Yaskawa for more information on DriveWizard Plus.

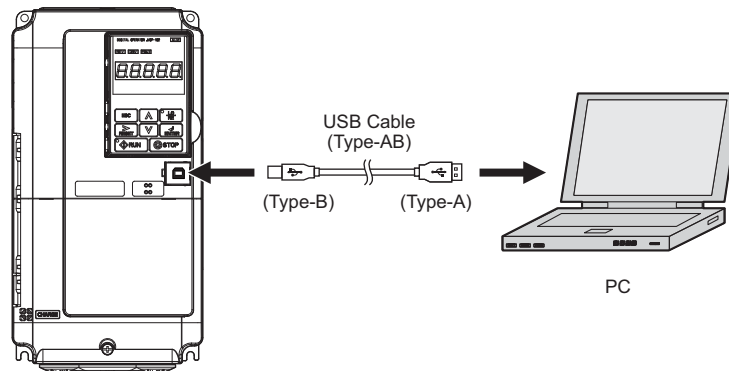


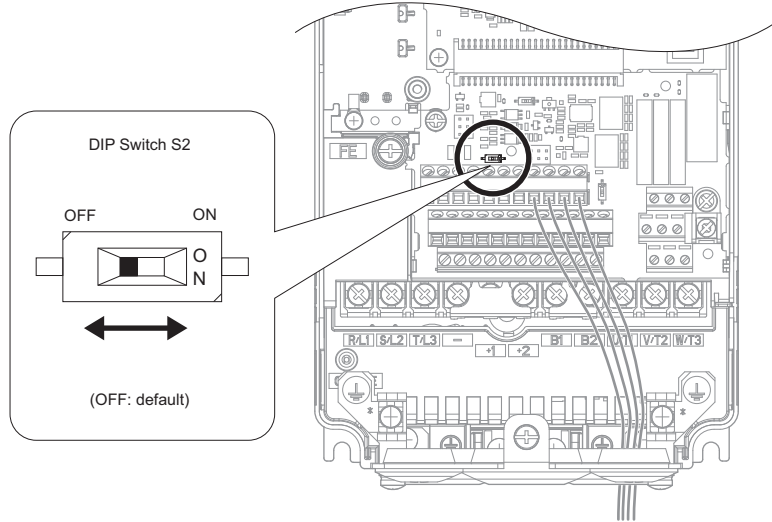
Figure 3.34 Connecting to a PC (USB)

## 3.13 MEMOBUS/Modbus Termination

This drive is equipped with a built in termination resistor for the RS-422/RS-485 communication port. DIP switch S2 enables or disabled the termination resistor as shown in [Figure 3.35](#). The OFF position is the default. The termination resistor should be placed to the ON position when the drive is the last in a series of slave drives.

**Table 3.20 MEMOBUS/Modbus Switch Settings**

S2 Position	Description
ON	Internal termination resistor ON
OFF	Internal termination resistor OFF (default setting)



**Figure 3.35 DIP Switch S2**

**Note:** Refer to the [MEMOBUS/Modbus Communications on page 411](#) for details on MEMOBUS/Modbus.

## 3.14 External Interlock

Systems that may be affected if the drive faults out should be interlocked with the drive's fault output and ready signal.

### ◆ Drive Ready

When the "Drive ready" signal has been set to one of the multi-function contact outputs, that output will close whenever the drive is ready to accept a Run command or is already running. Under the following conditions the Drive ready signal will switch off and remain off, even if a Run command is entered:

- when the power supply is shut off.
- during a fault.
- when there is problem with the control power supply.
- when a parameter setting error makes the drive unable to run even if a Run command has been entered.
- when a fault such as overvoltage or undervoltage is triggered as soon as the Run command is entered.
- when the drive is in the Programming mode and will not accept a Run command even when entered.

### ■ Interlock Circuit Example

Two drives running a single application might interlock with the controller using the Drive ready and Fault output signals as shown below. The figure illustrates how the application would not be able to run if either drive experiences a fault or is unable to supply a Drive ready signal.

Terminal	Output Signal	Parameter Setting
MA, MB, MC	Fault	–
M1-M2	Drive Ready	H2-01 = 06

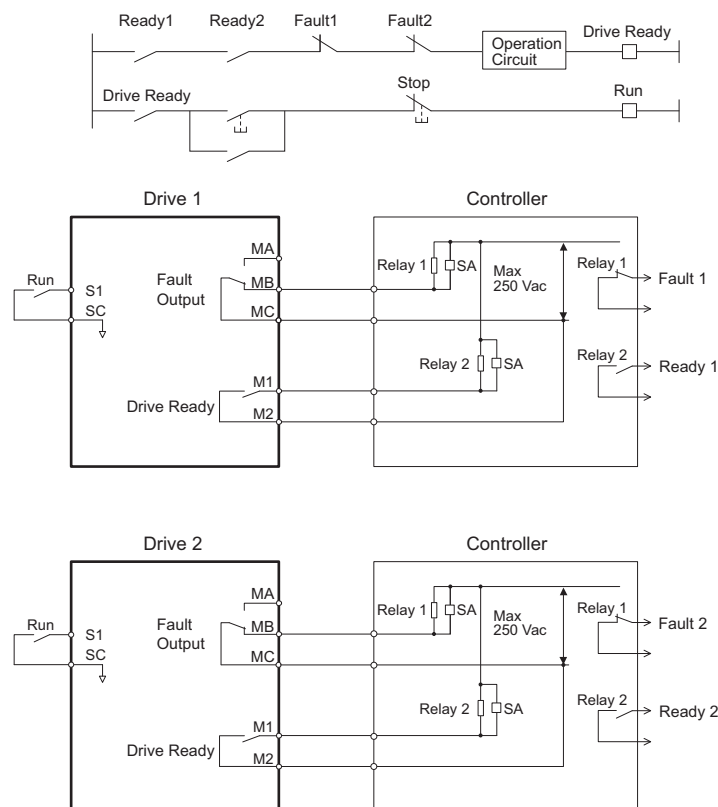


Figure 3.36 Interlock Circuit Example

# 3.15 Wiring Checklist

<input checked="" type="checkbox"/>	No.	Item	Page
<b>Drive, peripherals, option cards</b>			
<input type="checkbox"/>	1	Check drive model number to ensure receipt of correct model.	27
<input type="checkbox"/>	2	Make sure you have the correct braking options, DC reactors, noise filters, and other peripheral devices.	333
<input type="checkbox"/>	3	Check the option card model number.	333
<b>Installation area and physical setup</b>			
<input type="checkbox"/>	4	Ensure that the area surrounding the drive complies with specifications.	44
<b>Power supply voltage, output voltage</b>			
<input type="checkbox"/>	5	The voltage from the power supply should be within the input voltage specification range of the drive.	170
<input type="checkbox"/>	6	The voltage rating for the motor should match the drive output specifications.	29 390
<input type="checkbox"/>	7	Verify that the drive is properly sized to run the motor.	29 390
<b>Main circuit wiring</b>			
<input type="checkbox"/>	8	Confirm proper branch circuit protection as specified by national and local codes.	58
<input type="checkbox"/>	9	Properly wire the power supply to drive terminals R/L1, S/L2, and T/L3. <b>Note:</b> Confirm the following when wiring models CIMR-E□4A0930 and 4A1200: <ul style="list-style-type: none"> <li>• Remove the jumpers shorting terminals R/L1-R1/L11, S/L2-S1/L21, and T/L3-T1/L31 when operating with 12-phase rectification. Refer to <a href="#">12-Phase Rectification on page 62</a> for more information.</li> <li>• When operating without 12-phase rectification, properly wire terminals R1/L11, S1/L21, and T1/L31 in addition to terminals R1/L1, S1/L2, and T1/L3</li> </ul>	61
<input type="checkbox"/>	10	Properly wire the drive and motor together. The motor lines and drive output terminals R/T1, V/T2, and W/T3 should match in order to produce the desired phase order. If the phase order is incorrect, the drive will rotate in the opposite direction.	77
<input type="checkbox"/>	11	Use 600 Vac vinyl-sheathed wire for the power supply and motor lines.	73
<input type="checkbox"/>	12	Use the correct wire gauges for the main circuit. <a href="#">Refer to Wire Gauges and Tightening Torque on page 73.</a> <ul style="list-style-type: none"> <li>• When using comparatively long motor cable, calculate the amount of voltage drop.</li> </ul> <div style="border: 1px solid black; padding: 5px; width: fit-content; margin: 5px auto;"> <math display="block">\text{Motor rated voltage (V)} \times 0.02 \geq \sqrt{3} \times \text{wire resistance } (\Omega/\text{km}) \times \text{cable length (m)} \times \text{motor rated current (A)} \times 10^{-3}</math> </div> <ul style="list-style-type: none"> <li>• If the cable between the drive and motor exceeds 50 m, adjust the carrier frequency set to C6-02 accordingly.</li> </ul>	73 73 77
<input type="checkbox"/>	13	Properly ground the drive. Review <a href="#">page 78</a> .	78
<input type="checkbox"/>	14	Tightly fasten all terminal screws (control circuit terminals, grounding terminals). <a href="#">Refer to Wire Gauges and Tightening Torque on page 73.</a>	73
<input type="checkbox"/>	15	Set up overload protection circuits when running multiple motors from a single drive. <p style="margin-left: 20px;">MC1 - MCn ... magnetic contactor OL 1 - OLn ... thermal relay</p> <p><b>Note:</b> Close MC1 through MCn before operating the drive. (MC1 through MCn cannot be switched off during run.)</p>	-
<input type="checkbox"/>	16	If using dynamic braking options, install a magnetic contactor. Properly install the resistor, and ensure that overload protection shuts off the power supply.	340
<input type="checkbox"/>	17	Verify phase advancing capacitors, input noise filters, or ground fault circuit interrupters are NOT installed on the output side of the drive.	-
<b>Control circuit wiring</b>			
<input type="checkbox"/>	18	Use twisted-pair line for all drive control circuit wiring.	79
<input type="checkbox"/>	19	Ground the shields of shielded wiring to the GND ⊕ terminal.	83
<input type="checkbox"/>	20	If using a 3-wire sequence, properly set parameters for multi-function contact input terminals S1 through S8, and properly wire control circuits.	-
<input type="checkbox"/>	21	Properly wire any option cards.	82
<input type="checkbox"/>	22	Check for any other wiring mistakes. Only use a multimeter to check wiring.	-
<input type="checkbox"/>	23	Properly fasten the control circuit terminal screws in the drive. <a href="#">Refer to Wire Gauges and Tightening Torque on page 73.</a>	73
<input type="checkbox"/>	24	Pick up all wire clippings.	-
<input type="checkbox"/>	25	Ensure that no frayed wires on the terminal block are touching other terminals or connections.	-
<input type="checkbox"/>	26	Properly separate control circuit wiring and main circuit wiring.	-

<input checked="" type="checkbox"/>	No.	Item	Page
<input type="checkbox"/>	27	Analog signal line wiring should not exceed 50 m.	-



# Start-Up Programming & Operation

---

This chapter explains the functions of the digital operator and how to program the drive for initial operation.

<b>4.1 SECTION SAFETY</b> .....	<b>96</b>
<b>4.2 USING THE DIGITAL OPERATOR</b> .....	<b>97</b>
<b>4.3 THE DRIVE AND PROGRAMMING MODES</b> .....	<b>101</b>
<b>4.4 START-UP FLOWCHARTS</b> .....	<b>107</b>
<b>4.5 POWERING UP THE DRIVE</b> .....	<b>110</b>
<b>4.6 APPLICATION SELECTION</b> .....	<b>111</b>
<b>4.7 AUTO-TUNING</b> .....	<b>113</b>
<b>4.8 NO-LOAD OPERATION TEST RUN</b> .....	<b>120</b>
<b>4.9 TEST RUN WITH LOAD CONNECTED</b> .....	<b>121</b>
<b>4.10 VERIFYING PARAMETER SETTINGS AND BACKING UP CHANGES</b> .....	<b>122</b>
<b>4.11 TEST RUN CHECKLIST</b> .....	<b>124</b>

## 4.1 Section Safety

 **DANGER**

**Electrical Shock Hazard**

**Do not connect or disconnect wiring while the power is on.**

Failure to comply will result in death or serious injury.

 **WARNING**

**Electrical Shock Hazard**

**Do not operate equipment with covers removed.**

Failure to comply could result in death or serious injury.

The diagrams in this section may include drives without covers or safety shields to illustrate details. Be sure to reinstall covers or shields before operating the drives and run the drives according to the instructions described in this manual.

**Do not remove covers or touch circuit boards while the power is on.**

Failure to comply could result in death or serious injury.



## 4.2 Using the Digital Operator

Use the digital operator to enter run and stop commands, display data, edit parameters, as well as display fault and alarm information.

### ◆ Keys and Displays

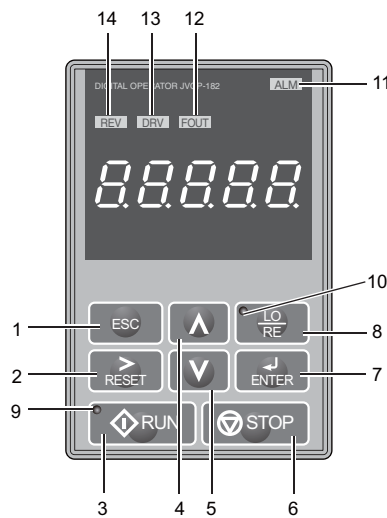


Figure 4.1 Keys and Displays on the Digital Operator

No.	Display	Name	Function
1		ESC Key	<ul style="list-style-type: none"> <li>Returns to the previous display.</li> <li>Moves the cursor one space to the left.</li> <li>Pressing and holding this button will return to the Frequency Reference display.</li> </ul>
2		RESET Key	<ul style="list-style-type: none"> <li>Moves the cursor to the right.</li> <li>Resets the drive to clear a fault situation.</li> </ul>
3		RUN Key	Starts the drive in the LOCAL mode. The Run LED <ul style="list-style-type: none"> <li>is on, when the drive is operating the motor.</li> <li>flashes during deceleration to stop or when the frequency reference is 0.</li> <li>flashes quickly the drive is disabled by a DI, the drive was stopped using a fast stop DI or a run command was active during power up.</li> </ul>
4		Up Arrow Key	Scrolls up to display the next item, selects parameter numbers and increments setting values.
5		Down Arrow Key	Scrolls down to display the previous item, selects parameter numbers and decrements setting values.
6		STOP Key <1>	Stops drive operation.
7		ENTER Key	<ul style="list-style-type: none"> <li>Enters parameter values and settings.</li> <li>Selects a menu item to move between displays.</li> </ul>
8		LO/RE Selection Key <2>	Switches drive control between the operator (LOCAL) and the control circuit terminals (REMOTE). The LED is on when the drive is in the LOCAL mode (operation from keypad).
9		RUN Light	Lit while the drive is operating the motor. Refer to page 99 for details.
10		LO/RE Light	Lit while the operator is selected to run the drive (LOCAL mode). Refer to page 99 for details.
11		ALM LED Light	Refer to LED Screen Displays on page 98.
12		FOUT LED Light	
13		DRV LED Light	
14		REV LED Light	

<1> The STOP key has highest priority. Pressing the STOP key will always cause the drive to stop the motor, even if a Run command is active at any external Run command source. To disable the STOP key priority, set parameter o2-06 to 0.

<2> The LO/RE key can only switch between LOCAL and REMOTE when the drive is stopped. To disable the LO/RE key to prohibit switching between LOCAL and REMOTE, set parameter o2-01 to 0.

## 4.2 Using the Digital Operator

### ◆ Digital Text Display

Text appears on the digital operator as shown below. This section explains the meaning of text as it appears on the display screen.



Lit	Flashing
	


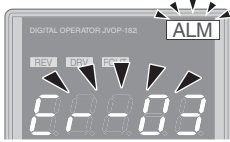

Table 4.1 Digital Text Display

Text	LED	Text	LED	Text	LED	Text	LED
0	0	9	9	I	i	R	r
1	1	A	A	J	j	S	s
2	2	B	b	K	k	T	t
3	3	C	c	L	l	U	u
4	4	D	d	M	m	V	v
5	5	E	E	N	n	W	w
6	6	F	F	O	o	X	none
7	7	G	G	P	p	Y	y
8	8	H	H	Q	q	Z	none

<1> Displayed in two digits.

### ◆ LED Screen Displays

Table 4.2 LED Screen Displays

Display	Lit	Flashing	Off
<b>ALM</b>	The drive has detected an alarm or error	<ul style="list-style-type: none"> <li>When an alarm occurs</li> <li>oPE detected</li> <li>When a fault or error occurs during Auto-Tuning</li> </ul>	Normal state (no fault or alarm)
<b>REV</b>	Motor is rotating in reverse	-	Motor is rotating forward
<b>DRV</b>	<ul style="list-style-type: none"> <li>The drive is in the Drive Mode</li> <li>During Auto-Tuning</li> </ul>	When DriveWorksEZ is used <1>	<ul style="list-style-type: none"> <li>The drive is in the Programming Mode</li> <li>The drive will not accept a Run command</li> </ul>
<b>FOUT</b>	When the display shows the output frequency	-	When a display other than the output frequency monitor is shown.
As illustrated in this manual			

<1> Refer to the DriveWorksEZ instruction manual for further information.

◆ LO/RE LED and RUN LED Indications

Table 4.3 LO/RE LED and RUN LED Indications

LED	Lit	Flashing	Flashing Quickly <f>	Off
	When source of the Run command is assigned to the digital operator (LOCAL)	—	—	Run command to be given from a device other than the digital operator (REMOTE)
	During run	<ul style="list-style-type: none"> <li>During deceleration to stop</li> <li>When a Run command is input and frequency reference is 0 Hz</li> </ul>	<ul style="list-style-type: none"> <li>While the drive is set for LOCAL, a Run command was entered to the input terminals after which the drive was then switched to REMOTE.</li> <li>A Run command was entered via the input terminals while not in the Drive Mode.</li> <li>During deceleration when a Fast Stop command was entered.</li> <li>The drive output is shut off by the Hardwire Baseblock function.</li> <li>While the drive was running in the REMOTE mode, the STOP key was pushed.</li> <li>The drive was powered up with b1-17 = 0 (default) while the Run command is active.</li> </ul>	During stop
Examples				

<f> Refer to [Figure 4.2](#) for the difference between “flashing” and “flashing quickly”.

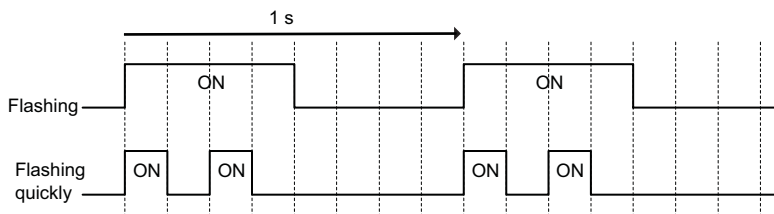


Figure 4.2 RUN LED Status and Meaning

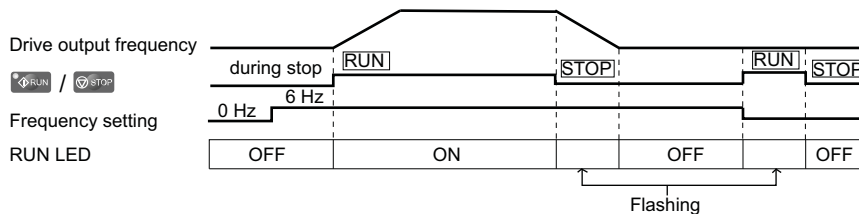


Figure 4.3 RUN LED and Drive Operation

◆ Menu Structure for Digital Operator

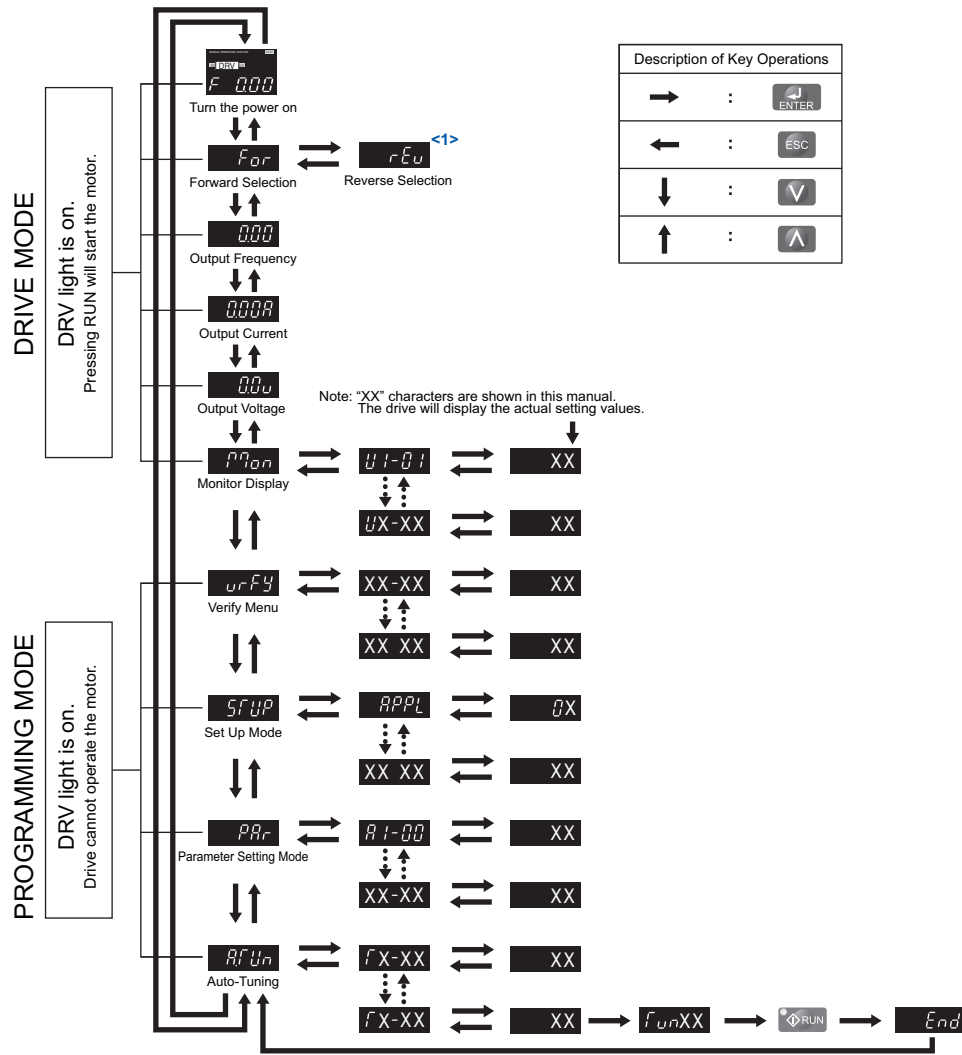


Figure 4.4 Digital Operator Menu and Screen Structure

<1> Reverse can only be selected when the drive is set for LOCAL. Details on switching between forward and reverse can be found in *Navigating the Drive and Programming Modes on page 101*.

## 4.3 The Drive and Programming Modes

The drive has a Programming Mode to program the drive for operation, and a Drive Mode used to actually run the motor.



**Drive Mode:** In the Drive Mode, the user can start the motor and observe operation status with the monitors that are available. Parameter settings cannot be edited or changed when in the Drive Mode.




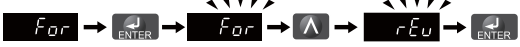








**Programming Mode:** The Programming Mode allows access to edit, adjust, and verify parameters, as well as perform Auto-Tuning. Unless set to allow a Run command, the drive will not accept a Run command when the digital operator is in the Programming Mode.

**Note:** If parameter b1-08 is set to 0 the drive will accept a Run command only in the Drive Mode. When editing parameters, the user must first exit the Programming Mode and enter the Drive Mode before starting the motor.

**Note:** To allow the drive to run the motor while in the Programming Mode, set b1-08 to 1.

### ◆ Navigating the Drive and Programming Modes

The drive is set to operate in Drive Mode when it is first powered up. Switch between display screens by using the  and  keys.

Mode	Contents	Operator Display	Description
Power Up	Frequency Reference (default)		This display screen allows the user to monitor and change the frequency reference while the drive is running. <i>Refer to The Drive and Programming Modes on page 101.</i> <b>Note:</b> The user can select the data displayed when the drive is first powered up with parameter o1-02.
Drive Mode			
	Forward/Reverse		This display shows the direction that has been selected when the drive is controlled by a REMOTE source. When the drive is set for LOCAL, the user can switch between FWD and REV as shown below.  <i>For</i> - Forward rotation <i>rEv</i> - Reverse rotation <b>Note:</b> For applications that should not run in reverse (fans, pumps, etc.), set parameter b1-04 = "1" to prohibit the motor from rotating in reverse.
			
	Output Frequency Display		Displays the frequency that is output from the drive.
			
	Output Current Display		Monitors the output current of the drive.
			
	Output Voltage Reference (default)		Shows the data that selected for display by the user in parameter o1-01. The default setting displays drive output voltage (o1-01 = 106). <i>Refer to o1: Digital Operator Display Selection on page 388.</i>
Drive Mode			
	Monitor Display		Lists the monitor parameters (U□-□□ parameters) available in the drive.

### 4.3 The Drive and Programming Modes

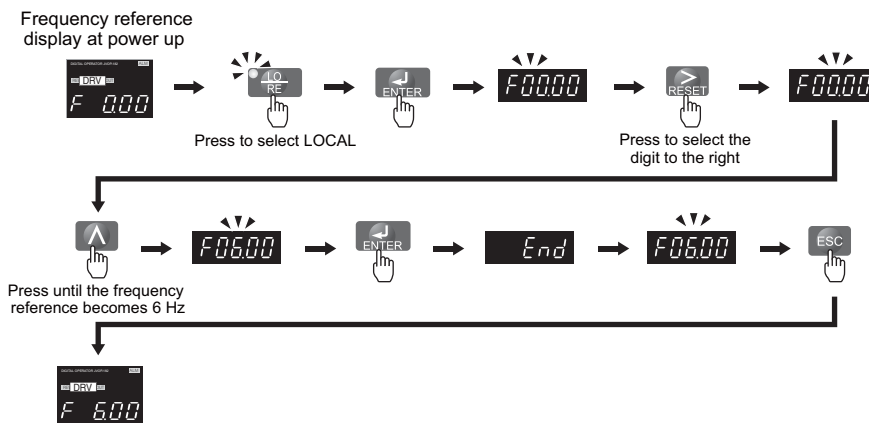
Mode	Contents	Operator Display	Description
Programming Mode			
	Verify Menu		Lists all parameters that have been edited or changed from default settings. → Refer to <a href="#">Verifying Parameter Changes: Verify Menu on page 104</a> .
	Setup Group		A select list of parameters necessary to get the drive operating quickly. → Refer to <a href="#">Using the Setup Group on page 104</a> . <b>Note:</b> Parameters listed in the Setup Group differ depending the Application Preset in parameter A1-06. Refer to <a href="#">Application Selection on page 111</a> .
	Parameter Setting Mode		Allows the user to access and edit all parameter settings. → Refer to <a href="#">Parameter Table on page 360</a> .
Programming Mode	Auto-Tuning Mode		Motor parameters are calculated and set automatically. → Refer to <a href="#">Auto-Tuning on page 113</a> .
Drive Mode	Frequency Reference		Returns to the frequency reference display screen.

#### ■ Drive Mode Details

The following actions are possible in the Drive Mode:

- Run and stop the drive
- Monitor the operation status of the drive (frequency reference, output frequency, output current, output voltage, etc.)
- View information on an alarm
- View a history of alarms that have occurred

**Figure 4.5** illustrates how to change the frequency reference from F 0.00 (0 Hz) to F 6.00 (6 Hz) while in the Drive Mode. This example assumes the drive is set to LOCAL.



**Figure 4.5** Setting the Frequency Reference while in the Drive Mode

**Note:** The drive will not accept a change to the frequency reference until the ENTER key is pressed after the frequency reference is entered. This feature prevents accidental setting of the frequency reference. To have the drive accept changes to the frequency reference as soon as changes are made without requiring the ENTER key, set o2-05 to 1.

## ■ Programming Mode Details

The following actions are possible in the Programming Mode:

- **Parameter Setting Mode:** Access and edit all parameter settings
- **Verify Menu:** Check a list of parameters that have been changed from their original default values
- **Setup Group:** Access a list of commonly used parameters to simplify setup (see *Simplified Setup Using the Setup Group on page 104*)
- **Auto-Tuning Mode:** Automatically calculates and sets motor parameters to optimize drive performance

## ◆ Changing Parameter Settings or Values

This example explains changing C1-02 (Deceleration Time 1) from 30.0 seconds (default) to 20.0 seconds.

Step		Display/Result
1.	Turn on the power to the drive. The initial display appears.	
2.	Press the  or  key until the Parameter Setting Mode screen appears.	
3.	Press the  key to enter the parameter menu tree.	
4.	Press  or  key to select the C parameter group.	
5.	Press  two times.	
6.	Press  or  key to select the parameter C1-02.	
7.	Press  to view the current setting value (10.0 s). Left digit flashes.	
8.	Press  until the desired number is selected. "1" flashes.	
9.	Press the  key and enter 0020.0.	
10.	Press  and the drive will confirm the change.	
11.	The display automatically returns to the screen shown in Step 4.	
12.	Press the  key until back at the initial display.	

## 4.3 The Drive and Programming Modes











### ◆ Verifying Parameter Changes: Verify Menu

The Verify Menu lists edited parameters from the Programming Mode or as a result of Auto-Tuning. It helps determine which settings have been changed, and is particularly useful when replacing a drive. If no settings have been changed, the Verify Menu will read *none*. The Verify Menu also allows users to quickly access and re-edit any parameters settings that have been changed.

**Note:** The Verify Menu will not display parameters from the A1 group (except for A1-02) even if those parameters have been changed from their default settings.

The following example is a continuation of the steps above. Here, parameter C1-02 is accessed using the Verify Menu, and is changed again from 30.0 s to 20.0 s.

To check the list of edited parameters:

Step			Display/Result
1.	Turn on the power to the drive. The initial display appears.	→	
2.	Press  or  until the display shows the top of the Verify Menu.	→	
3.	Press  to enter the list of parameters that have been edited from their original default settings. If parameters other than C1-02 have been changed, use the  or  key to scroll until C1-02 appears.	→	
4.	Press the  key to access the setting value. Left digit flashes.	→	

### ◆ Simplified Setup Using the Setup Group

In the Setup Group, the drive lists the basic parameters needed to set up the drive for the application. It provides a simplified way to get the application running right away by showing only the most important parameters.

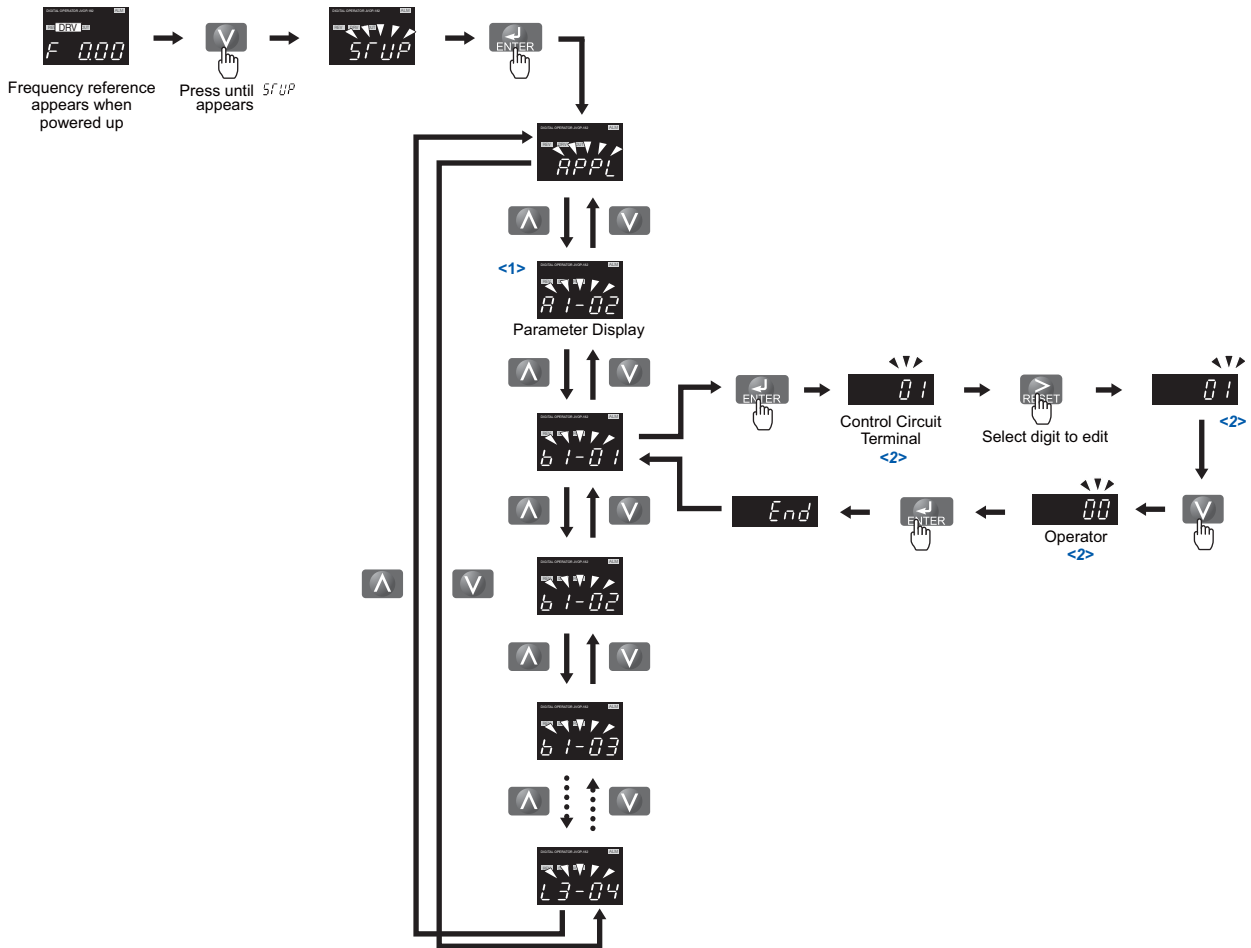
#### ■ Using the Setup Group

*Figure 4.6* illustrates how to enter and how to change parameters in the Setup Group.

The first display shown when entering the Setup Group is the Application Selection menu. Skipping this display will keep the current Setup Group parameter selection. The default setting for the Setup Group is a group of parameters most commonly use in general-purpose applications. Pressing the ENTER key from the Application Selection display and selecting an Application Preset will change the Setup Group to parameters optimal for the application selected. *Refer to Application Selection on page 111.*

In this example, the Setup Group is accessed to change b1-01 from 1 to 0. This changes the source of the frequency reference from the control circuit terminals to the digital operator.





<1> Use the up and down arrow keys to scroll through the Setup Group. Press the ENTER key to view or change parameter settings.  
 <2> To return to the previous menu without saving changes, press the ESC key.

Figure 4.6 Setup Group Example

■ Setup Group Parameters

Table 4.4 lists parameters available by default in the Setup Group. When an Application Preset has been selected in parameter A1-06 or the Application Selection display of the Setup Group, the parameters selected for the Setup Group will change automatically. Refer to *Application Selection on page 111*.

If the desired parameter is not listed in the Setup Group, go to the Programming Mode.

### 4.3 The Drive and Programming Modes

**Table 4.4 Setup Group Parameters**

Parameter	Name
A1-02	Control Method Selection
b1-01	Frequency Reference Selection 1
b1-02	Run Command Selection 1
b1-03	Stopping Method Selection
C1-01	Acceleration Time 1
C1-02	Deceleration Time 1
C6-02	Carrier Frequency Selection
d2-01	Frequency Reference Upper Limit
d2-02	Frequency Reference Lower Limit
E1-01	Input Voltage Setting
E1-04	Maximum Output Frequency
E1-05	Maximum Voltage
E1-06	Base Frequency
E2-01	Motor Rated Current
E2-11	Motor Rate Power
F6-01	Communications Error Operation Selection

Parameter	Name
H3-03	Terminal A1 Gain Setting
H3-04	Terminal A1 Bias Setting
H3-11	Terminal A2 Gain Setting
H3-12	Terminal A2 Bias Setting
L2-01	Momentary Power Loss Operation Selection
L2-02	Momentary Power Loss Ride Thru Time
L4-05	Frequency Reference Loss Detection Selection
L4-06	Frequency Reference at Reference Loss
L5-01	Number of Auto Restart Attempts
L5-03	Time to Continue Making Fault Restarts
L6-01	Torque Detection Selection 1
L6-02	Torque Detection level 1
L6-03	Torque Detection Time 1
o2-03	User Parameter Default Value
o2-05	Frequency Reference Setting Method Selection

**Note:** Parameter availability depends on the control mode set in A1-02 that is used to run the drive and motor. Consequently, some of the parameters listed above may not be accessible in certain control modes.

#### ◆ Switching Between LOCAL and REMOTE

When the drive is set to accept the Run command from the digital operator RUN key, this is referred to as LOCAL mode. When the drive is set to accept the Run command from an external device (via the input terminals, serial communications, etc.) this is referred to as REMOTE mode.

**WARNING! Sudden Movement Hazard.** The drive may start unexpectedly if the Run command is already applied when switching from LOCAL mode to REMOTE mode when b1-07 = 1, resulting in death or serious injury. Be sure all personnel are clear of rotating machinery.

The operation can be switched between LOCAL and REMOTE either by using the LO/RE key on the digital operator or a digital input.

- Note:**
1. After selecting LOCAL, the LO/RE light will remain lit.
  2. The drive will not allow the user to switch between LOCAL and REMOTE during run.

#### ■ Using the LO/RE Key on the Digital Operator

Step	Display/Result
1. Turn on the power to the drive. The initial display appears.	
2. Press . The LO/RE light will light up. The drive is now in LOCAL. To set the drive for REMOTE operation, press the  key again.	 

#### ■ Using Input Terminals S1 through S8 to Switch between LO/RE

The user can also switch between LOCAL and REMOTE modes using one of the digital input terminals S1 through S8 (set the corresponding parameter H1-□□ to “1”).

When setting the multi-function input terminals,

- Note:**
1. Refer to Parameter Table on page 360 for a list of digital input selections.
  2. Setting H1-□□ to 1 disables the LO/RE key on the digital operator.

## 4.4 Start-Up Flowcharts

The flowcharts in this section summarize basic steps required to start the drive. Use the flowcharts to determine the most appropriate start-up method for a given application. The charts are intended as a quick reference to help familiarize the user with start-up procedures.

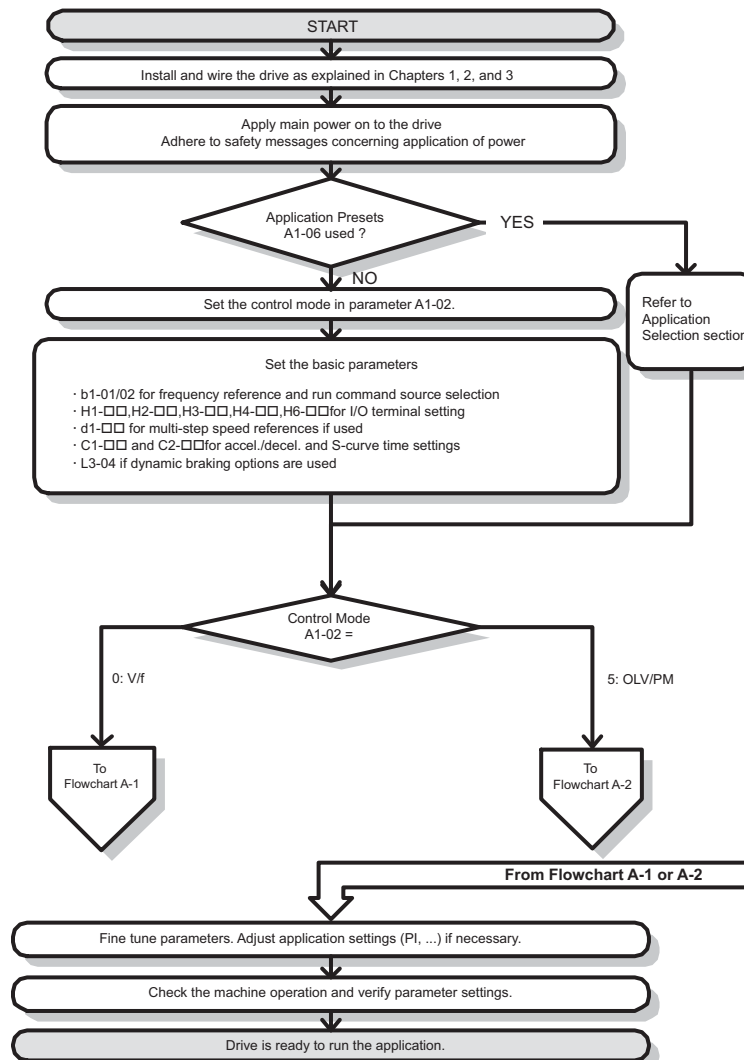
- Note:** 1. Function availability differs for drive models CIMR-E□4A0930 and 4A1200. *Refer to Parameter Groups on page 359* for details.  
2. Refer to *Application Selection on page 111* to set up the drive using one of the application presets.

Flowchart	Subchart	Objective	Page
A	–	Basic startup procedure and motor tuning	107
–	A-1	Simple motor setup using V/f mode	108
–	A-2	Setting up the drive to run a permanent magnet (PM) motor	109

**Note:** To set up the drive using one of the Application Presets, refer to *Application Selection on page 111*.

### ◆ Flowchart A: Basic Start-up and Motor Tuning

Flowchart A in *Figure 4.7* describes a basic start-up sequence. This sequence varies slightly depending on the application. Use drive default parameter settings in simple applications that do not require high precision.



**Figure 4.7 Basic Start-up**

**Note:** When the motor cable length has changed for more than 50 m after Auto-Tuning has been performed (e.g., after the drive has been set up and then later installed in a different location), execute Stationary Auto-Tuning for resistance between motor lines once the drive is installed in its final installation location.

**Note:** Auto-Tuning should be performed again after installing an AC reactor or other such components to the output side of the drive.

◆ Subchart A-1: Simple Motor Setup Using V/f Control

Flowchart A1 in *Figure 4.8* describes simple motor setup for V/f Control. V/f Control is suited for more basic applications such as fans and pumps. This procedure illustrates Energy Savings and Speed Estimation Speed Search.

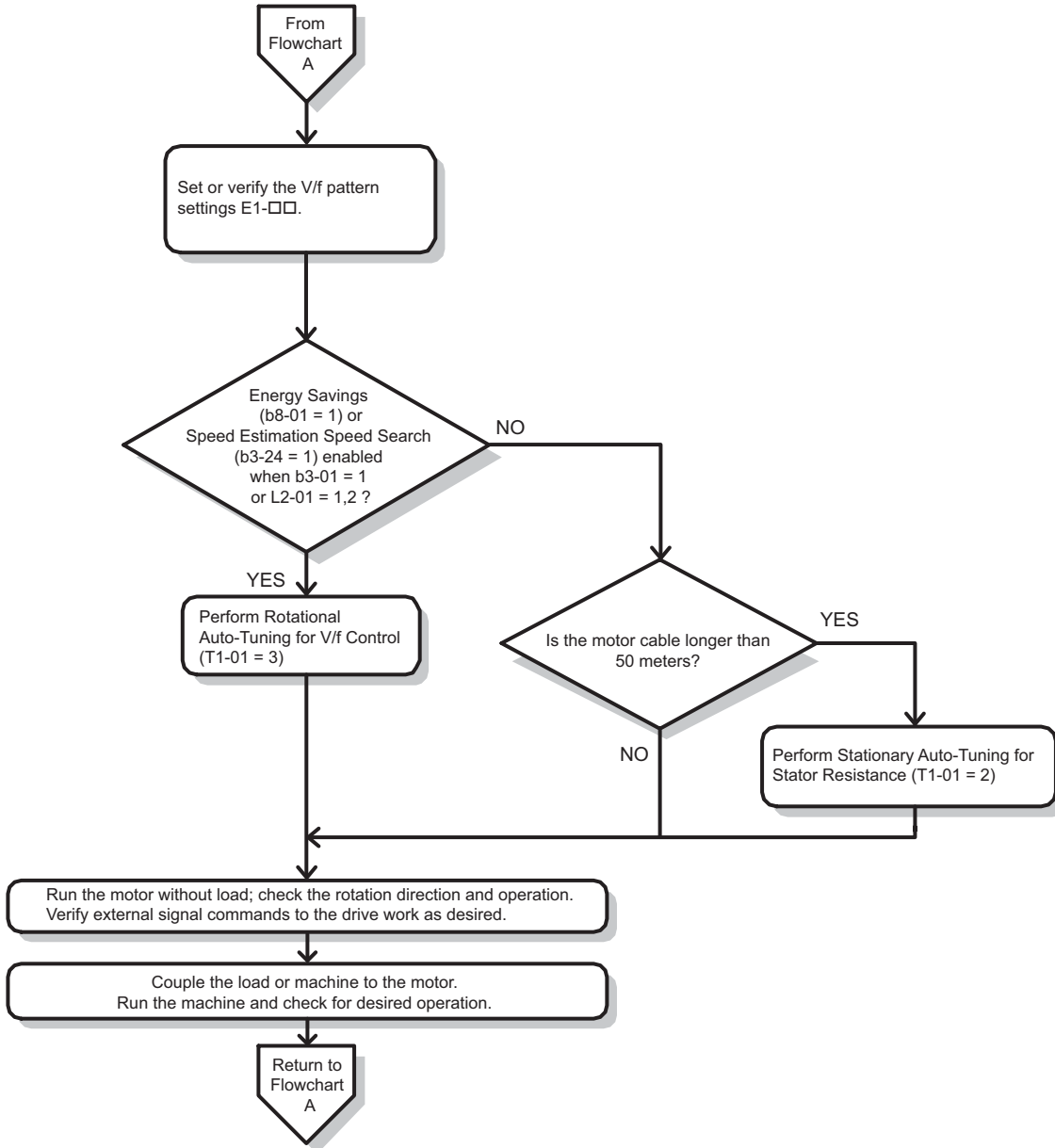
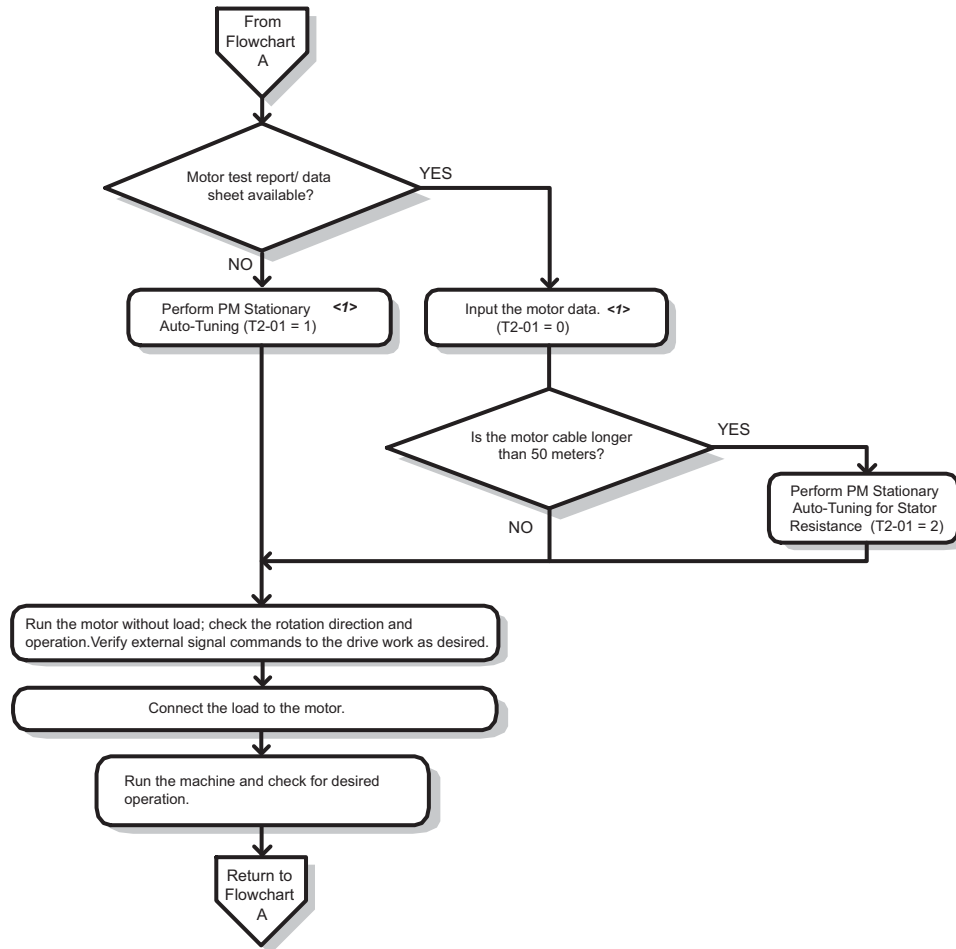


Figure 4.8 Simple Motor Setup with Energy Savings or Speed Search

### ◆ Subchart A-2: Operation with Permanent Magnet Motors

Flowchart A2 in [Figure 4.9](#) describes the set-up procedure for running a PM motor in Open Loop Vector Control. PM motors can be used for more energy-efficient operation in reduced or variable torque applications.



<f> Enter the motor code to E5-01 when using a Yaskawa PM motor (SMRA Series, SSR1 Series). If using a motor from another manufacturer, enter FFFF.

**Figure 4.9 Operation with Permanent Magnet Motors**

## 4.5 Powering Up the Drive

### ◆ Powering Up the Drive and Operation Status Display

#### ■ Powering Up the Drive

Review the following checklist before turning the power on.



Item to Check	Description
Power supply voltage	Ensure the power supply voltage is correct: 200 V class: 3-phase 200 to 240 Vac 50/60 Hz 400 V class: 3-phase 380 to 480 Vac 50/60 Hz
	Properly wire the power supply input terminals (R/L1, S/L2, T/L3). <I>
	Check for proper grounding of drive and motor.
Drive output terminals and motor terminals	Properly wire drive output terminals U/T1, V/T2, and W/T3 with motor terminals U, V, and W.
Control circuit terminals	Check control circuit terminal connections.
Drive control terminal status	Open all control circuit terminals (off).
Status of the load and connected machinery	Decouple the motor from the load.

<I> Check the following when connecting models CIMR-E□4A0930 and 4A1200:

- Remove the jumpers on R/L1-R1/L11, S/L2-S1/L21, and T/L3-T1/L31 when 12-phase rectification. [Refer to 12-Phase Rectification on page 62](#) for details.
- Properly connect the inputs on terminals R1/L11, S1/L21, and T1/L31 when not using 12-phase rectification.

#### ■ Status Display

When the power supply to the drive is turned on, the digital operator lights will appear as follows:

No.	Name	Description
Normal Operation		The data display area displays the frequency reference. [DRV] is lit.
Fault	 External fault (example)	Data displayed varies by the type of fault. Refer to <a href="#">Fault Displays, Causes, and Possible Solutions on page 265</a> for more information and possible solution. [ALM] and [DRV] are lit.

## 4.6 Application Selection

Several Application Presets are available to facilitate drive setup for commonly used applications. Selecting one of these Application Presets automatically assigns functions to the input and output terminals, and sets certain parameters to values appropriate for the application that was selected. In addition, the parameters most likely to be changed are assigned to the group of User Parameters, A2-01 through A2-16. User Parameters are part of the Setup Group, and provide quicker access to by eliminating the need to scroll through multiple menus.

An Application Preset can either be selected from the Application Selection display in the Setup Group (*Refer to Simplified Setup Using the Setup Group on page 104*) or in parameter A1-06. The following presets can be selected:

**Note:** An Application Preset can only be selected if all drive parameters are on at their original default settings. It may be necessary to initialize the drive by setting A1-03 to “2220” or “3330” prior to selecting an Application Preset.

**WARNING!** Confirm the drive I/O signals and external sequence before performing a test run. Setting parameter A1-06 may change the I/O terminal function automatically from the default setting. Failure to comply may result in death or serious injury.

No.	Parameter Name	Setting Range	Default
A1-06	Application Presets	0: Disabled 1: Water supply pump 3: Exhaust fan 4: HVAC 5: Compressor	0

### ◆ Setting 1: Water Supply Pump Application

Table 4.5 Water Supply Pump: Parameter Settings

No.	Name	Default Setting
A1-02	Control Method Selection	0: V/f Control
b1-04	Reverse Operation Selection	1: Reverse Prohibited
C1-01	Acceleration Time 1	1.0 s
C1-02	Deceleration Time 1	1.0 s
E1-03	V/f Pattern Selection	0FH
E1-07	Mid Output Frequency	30.0 Hz
E1-08	Mid Output Frequency Voltage	50.0 V
L2-01	Momentary Power Loss Operation Selection	1: Enabled
L3-04	Stall Prevention Selection during Deceleration	1: Enabled

Table 4.6 Water Supply Pump: User Parameters (A2-01 to A2-16)

No.	Parameter Name	No.	Parameter Name
b1-01	Frequency Reference Selection	E1-08	Mid Output Frequency Voltage
b1-02	Run Command Selection	E2-01	Motor Rated Current
b1-04	Reverse Operation Selection	H1-05	Multi-Function Digital Input Terminal S5 Function Selection
C1-01	Acceleration Time 1	H1-06	Multi-Function Digital Input Terminal S6 Function Selection
C1-02	Deceleration Time 1	H1-07	Multi-Function Digital Input Terminal S7 Function Selection
E1-03	V/f Pattern Selection	L5-01	Number of Auto Restart Attempts
E1-07	Mid Output Frequency	–	–

### ◆ Setting 3: Exhaust Fan Application

Table 4.7 Exhaust Fan: Parameter Settings

No.	Parameter Name	Default Setting
A1-02	Control Method Selection	0: V/f Control
b1-04	Reverse Operation Selection	1: Reverse Prohibited
E1-03	V/f Pattern Selection	0FH
E1-07	Mid Output Frequency	30.0 Hz
E1-08	Mid Output Frequency Voltage	50.0 V
L2-01	Momentary Power Loss Operation Selection	1: Enabled
L3-04	Stall Prevention Selection during Deceleration	1: Enabled

## 4.6 Application Selection

**Table 4.8 Exhaust Fan: User Parameters (A2-01 to A2-16)**

No.	Parameter Name	No.	Parameter Name
b1-01	Frequency Reference Selection	E1-07	Mid Output Frequency
b1-02	Run Command Selection	E1-08	Mid Output Frequency Voltage
b1-04	Reverse Operation Selection	E2-01	Motor Rated Current
b3-01	Speed Search Selection at Start	H1-05	Multi-Function Digital Input Terminal S5 Function Selection
C1-01	Acceleration Time 1	H1-06	Multi-Function Digital Input Terminal S6 Function Selection
C1-02	Deceleration Time 1	H1-07	Multi-Function Digital Input Terminal S7 Function Selection
E1-03	V/f Pattern Selection	L5-01	Number of Auto Restart Attempts

### ◆ Setting 4: HVAC Fan Application

**Table 4.9 HVAC Fan: Parameter Settings**

No.	Parameter Name	Default Setting
A1-02	Control Method Selection	0: V/f Control
b1-04	Reverse Operation Selection	1: Reverse Prohibited
b1-17	Run Command at Power Up	1: Run command issued, motor operation start
C6-02	Carrier Frequency Selection	3: 8.0 kHz
H2-03	Terminals M5,M6 Function Selection	39: Watt Hour Pulse Output
L2-01	Momentary Power Loss Operation Selection	2: CPU Power Active - Drive will restart if power returns prior to control power supply shut down.
L8-03	Overheat Pre-Alarm Operation Selection	4: Operation at lower speed
L8-38	Carrier Frequency Reduction	2: Enabled across entire frequency range.

**Table 4.10 HVAC Fan: User Parameters (A2-01 to A2-16)**

No.	Parameter Name	No.	Parameter Name
b1-01	Frequency Reference Selection	d2-02	Frequency Reference Lower Limit
b1-02	Run Command Selection	E1-03	V/f Pattern Selection
b1-03	Stopping Method Selection	E1-04	Max Output Frequency
b1-04	Reverse Operation Selection	E2-01	Motor Rated Current
C1-01	Acceleration Time 1	H3-11	Terminal A2 Gain Setting
C1-02	Deceleration Time 1	H3-12	Terminal A2 Input Bias
C6-02	Carrier Frequency Selection	L2-01	Momentary Power Loss Operation Selection
d2-01	Frequency Reference Upper Limit	o4-12	kWh Monitor Initial Value Selection

### ◆ Setting 5: Compressor Application

**Table 4.11 Compressor: Parameter Settings**

No.	Parameter Name	Default Setting
A1-02	Control Method Selection	0: V/f Control
b1-04	Reverse Operation Selection	1: Reverse Prohibited
C1-01	Acceleration Time 1	5.0 s
C1-02	Deceleration Time 1	5.0 s
E1-03	V/f Pattern Selection	0FH
L2-01	Momentary Power Loss Operation Selection	1: Enabled
L3-04	Stall Prevention Selection during Deceleration	1: Enabled

**Table 4.12 Compressor: User Parameters (A2-01 to A2-16):**

No.	Parameter Name	No.	Parameter Name
b1-01	Frequency Reference Selection	E1-03	V/f Pattern Selection
b1-02	Run Command Selection	E1-07	Mid Output Frequency
b1-04	Reverse Operation Selection	E1-08	Mid Output Frequency Voltage
C1-01	Acceleration Time 1	E2-01	Motor Rated Current
C1-02	Deceleration Time 1	-	-



## 4.7 Auto-Tuning

### ◆ Types of Auto-Tuning

The drive offers different types of Auto-Tuning for induction motors and permanent magnet motors. The type of Auto-Tuning used differs further based on the control mode and other operating conditions. Refer to the tables below to select the type of Auto-Tuning that best suits the application. Directions on how to execute Auto-Tuning are listed in [Start-Up Flowcharts on page 107](#).

**Note:** The drive will only show Auto-Tuning parameters that are valid for the control mode that has been set to A1-02. If the control mode is for an induction motor, the Auto-Tuning parameters for PM motors will not be available. If the control mode is for a PM motor, the Auto-Tuning parameters for induction motors will not be available.

### ■ Auto-Tuning for Induction Motors of V/f control

This feature automatically sets the V/f pattern and motor parameters E1-□□ and E2-□□ for an induction motor.

**Table 4.13 Types of Auto-Tuning for Induction Motors of V/f control**

Type	Setting	Application Conditions and Benefits
Stationary Auto-Tuning for Line-to-Line Resistance	T1-01 = 2	<ul style="list-style-type: none"> <li>The drive is used in V/f Control and other Auto-Tuning selections not possible.</li> <li>Drive and motor capacities differ.</li> <li>Tunes the drive after the cable between the drive and motor has been replaced with a cable over 50 m long. Assumes Auto-Tuning has already been performed.</li> </ul>
Rotational Auto-Tuning for V/f Control	T1-01 = 3	<ul style="list-style-type: none"> <li>Recommended for applications using Speed Estimation Speed Search or using the Energy Saving function in V/f Control.</li> <li>Assumes motor can rotate while Auto-Tuning is executed. Increases accuracy for certain functions like torque compensation, slip compensation, Energy Saving, and Speed Search.</li> </ul>

[Table 4.14](#) lists the data that must be entered for Auto-Tuning. Make sure this data is available before starting Auto-Tuning. The information needed is usually listed on the motor nameplate or in the motor test report provided by the motor manufacturer. Also refer to page [108](#) and [109](#) for details on Auto-Tuning process and selections.

**Table 4.14 Auto-Tuning Input Data**

Input Value	Input Parameter	Unit	Tuning Type (T1-01)	
			2 Line-to-Line Resistance	3 Rotational for V/f Control
Motor rated power	T1-02	kW	YES	YES
Motor rated voltage	T1-03	Vac	N/A	YES
Motor rated current	T1-04	A	YES	YES
Motor rated frequency	T1-05	Hz	N/A	YES
Number of motor poles	T1-06	–	N/A	YES
Motor rated Speed	T1-07	r/min	N/A	YES
Motor iron loss	T1-11	W	N/A	YES

### ■ Auto-Tuning for Permanent Magnet Motors of OLV control

Automatically sets the V/f pattern and motor parameters E1-□□ and E5-□□ when a PM motor is used.

**Table 4.15 Types of Auto-Tuning for Permanent Magnet Motors of OLV control**

Type	Setting	Application Conditions and Benefits
PM Motor Parameter Settings	T2-01 = 0	<ul style="list-style-type: none"> <li>Motor does not rotate during Auto-Tuning</li> <li>Motor test report or motor data like listed in <a href="#">Table 4.16</a> are available.</li> </ul>
PM Stationary Auto-Tuning	T2-01 = 1	<ul style="list-style-type: none"> <li>A motor test report listing motor data is not available. Drive automatically calculates and sets motor parameters.</li> </ul>
PM Stationary Auto-Tuning for Stator Resistance	T2-01 = 2	<ul style="list-style-type: none"> <li>Useful to tune the drive when the motor data were set up manually or by motor code and the cable is longer than 50 m. Should also be performed if the cable has changed after earlier tuning.</li> </ul>

[Table 4.16](#) lists the data that must be entered for Auto-Tuning. Make sure the data is available before starting Auto-Tuning. The information needed is usually listed on the motor nameplate or in the motor test report provided by the motor manufacturer. Also refer to page [109](#) for details on the tuning mode selection and the tuning process.

Table 4.16 Auto-Tuning Input Data

Input Value	Input Parameter	Unit	Tuning Type (T2-01)			
			0 Motor Parameter Settings		1 Stationary	2 Stationary Stator Resistance
Control Mode	A1-02	–	5			
Motor Code	T2-02	–	FFFFH	FFFFH	–	–
Motor Type	T2-03	–	N/A	N/A	YES	N/A
Motor rated power	T2-04	kW	N/A	YES	YES	N/A
Motor rated voltage	T2-05	Vac	N/A	YES	YES	N/A
Motor rated current	T2-06	A	N/A	YES	YES	YES
Motor rated frequency	T2-07	Hz	N/A	YES	YES	N/A
Number of motor poles	T2-08	–	N/A	YES	YES	N/A
Stator 1 Phase resistance	T2-10	Ω	YES	YES	N/A	N/A
d-axis inductance	T2-11	mH	YES	YES	N/A	N/A
q-axis inductance	T2-12	mH	YES	YES	N/A	N/A
Induced Voltage constant Unit Selection <1>	T2-13	mVs/rad (el.)	YES	YES	N/A	N/A
Voltage constant <2>	T2-14	mV/min (mech.)	YES	YES	N/A	N/A
Tuning pull-in current	T2-15	A	N/A	N/A	YES	N/A

<1> Only parameter T2-13 or T2-14 has to be input. Select one and leave the other empty.

<2> Depends on T2-13 setting.

## ◆ Before Auto-Tuning the Drive

Check the items below before Auto-Tuning the drive.

### ■ Basic Auto-Tuning Preparations

- Auto-Tuning requires the user to input data from the motor nameplate or motor test report. Make sure this data is available before Auto-Tuning the drive.
- For best performance, the drive input supply voltage must be greater than the motor rated voltage.
  - Note:** Better performance is possible when using a motor with a base voltage that is 20 V (40 V for 400 V class models) lower than the input supply voltage.
- To cancel Auto-Tuning, press the STOP key on the digital operator.
- When using a motor contactor, make sure it is closed throughout the Auto-Tuning process.
- [Table 4.17](#) describes digital input and output terminal operation while Auto-Tuning is executed.

Table 4.17 Digital Input and Output Operation During Auto-Tuning

Motor Type	Auto-Tuning Type	Digital Input	Digital Output
IM Motor	Stationary Auto-Tuning for Line-to-Line Resistance	Digital input functions are disabled.	Maintains the status at the start of Auto-Tuning
	Rotational Auto-Tuning for V/f Control		Functions the same as during normal operation
PM Motor	PM Motor Parameter Settings		Digital output functions are disabled.
	PM Stationary Auto-Tuning		Maintains the status at the start of Auto-Tuning
	PM Stationary Auto-Tuning for Stator Resistance		

### ■ Notes on Rotational Auto-Tuning

- To achieve optimal performance from Rotational Auto-Tuning, the load should be decoupled from the motor. Rotational Auto-Tuning is best suited for applications requiring high performance over a wide speed range.
- If motor and load can not be decoupled, reduce the load so that it is no greater than 30% of the rated load. Performing Rotational Auto-Tuning with a higher load will set motor parameters incorrectly, and can cause irregular motor rotation.
- Ensure the motor-mounted brake is fully released if installed.
- Connected machinery should be allowed to rotate the motor.

### ■ Notes on Stationary Auto-Tuning

Stationary Auto-Tuning modes analyze motor characteristics by injecting current into the motor for about one minute.

**WARNING! Electrical Shock Hazard.** When executing stationary Auto-Tuning, the motor does not rotate, however, power is applied. Do not touch the motor until Auto-Tuning is completed. Failure to comply may result in injury from electrical shock.

**WARNING! Sudden Movement Hazard.** If installed, do not release the mechanical brake during stationary Auto-Tuning. Inadvertent brake release may cause damage to equipment or injury to personnel. Ensure that the mechanical brake release circuit is not controlled by the drive multi-function digital outputs.

### Stationary Auto-Tuning for Line-to-Line Resistance and PM Motor Stator Resistance

- Perform when entering motor data manually while using motor cables longer than 50 m.
- If the motor cables have been replaced with line over 50 m long after Auto-Tuning as already been performed, then execute Stationary Auto-Tuning for line-to-line resistance.

### ◆ Auto-Tuning Interruption and Fault Codes

If tuning results are abnormal or the STOP key is pressed before completion, Auto-Tuning will be interrupted and a fault code will appear on the digital operator.

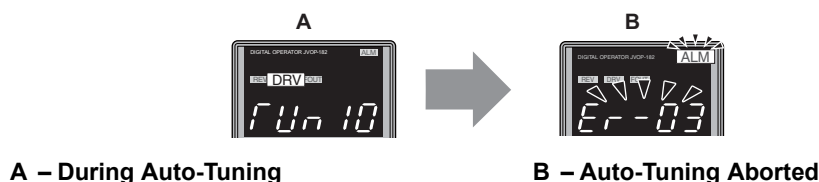


Figure 4.10 Auto-Tuning Aborted Display

### ◆ Auto-Tuning Operation Example

The following example demonstrates Rotational Auto-Tuning for V/f control (T1-01 = 3).

#### ■ Selecting the Type of Auto-Tuning

Step		Display/Result
1.	Turn on the power to the drive. The initial display appears.	
2.	Press the  or  key until the Auto-Tuning display appears.	
3.	Press  to begin setting parameters.	
4.	Press  to display the value for T1-01.	
5.	Save the setting by pressing .	
6.	The display automatically returns to the display shown in Step 3.	

#### ■ Enter Data from the Motor Nameplate

After selecting the type of Auto-Tuning, enter the data required from the motor nameplate.

**Note:** These instructions continue from Step 6 in “Selecting the Type of Auto-Tuning”.

Step		Display/Result
1.	Press  to access the motor output power parameter T1-02.	
2.	Press  to view the default setting.	
3.	Press  to select the digit to edit.	
4.	Press  and enter the motor power nameplate data in kW.	
5.	Press  to save the setting.	
6.	The display automatically returns to the display in Step 1.	

## 4.7 Auto-Tuning

Step		Display/Result
7.	Repeat Steps 1 through 5 to set the following parameters: <ul style="list-style-type: none"> <li>• T1-03, Motor Rated Voltage</li> <li>• T1-04, Motor Rated Current</li> <li>• T1-05, Motor Base Frequency</li> <li>• T1-06, Number of Motor Poles</li> <li>• T1-07, Motor Base Frequency</li> <li>• T1-11, Motor iron loss</li> </ul>	

**Note:** 1. For details on each setting, [Refer to Parameter Settings during Induction Motor Auto-Tuning: T1 on page 116](#).

**Note:** To execute Stationary Auto-Tuning for line-to-line resistance only, set parameters T1-02 and T1-04.

### ■ Starting Auto-Tuning

**WARNING! Sudden Movement Hazard.** The drive and motor may start unexpectedly during Auto-Tuning, which could result in death or serious injury. Ensure the area surrounding the drive motor and load are clear before proceeding with Auto-Tuning.

**WARNING! Electrical Shock Hazard.** High voltage will be supplied to the motor when Stationary Auto-Tuning is performed even with the motor stopped, which could result in death or serious injury. Do not touch the motor until Auto-Tuning has been completed.

**NOTICE:** Rotational Auto-Tuning will not function properly if a holding brake is engaged on the load. Failure to comply could result in improper operation of the drive. Ensure the motor can freely spin before beginning Auto-Tuning.

Enter the required information from the motor nameplate. Press to proceed to the Auto-Tuning start display.

**Note:** These instructions continue from Step 7 in “Enter Data from the Motor Nameplate”.

Step		Display/Result
1.	After entering the data listed on the motor nameplate, press  to confirm.	
2.	Press  to activate Auto-Tuning. <b>DRV</b> flashes. The drive begins by injecting current into the motor for about 1 min, and then starts to rotate the motor. <b>Note:</b> The first digit on the display always indicates 1. The second digit indicates the type of Auto-Tuning being performed.	
3.	Auto-Tuning finishes in approximately one to two minutes.	

### ◆ Parameter Settings during Induction Motor Auto-Tuning: T1

The T1-□□ parameters are used to set the Auto-Tuning input data for induction motor tuning.

**Note:** For motors that are to be operated in the field weakening range, first perform the Auto-Tuning with the base data. After Auto-Tuning is complete, change the maximum frequency E1-04 to the desired value.

#### ■ T1-01: Auto-Tuning Mode Selection

Sets the type of Auto-Tuning to be used. [Refer to Auto-Tuning for Induction Motors of V/f control on page 113](#) for details on the different types of Auto-Tuning.

No.	Name	Setting Range	Default
T1-01	Auto-Tuning Mode Selection	2, 3	2

**Setting 2: Stationary Auto-Tuning for Line-to-Line Resistance**

**Setting 3: Rotational Auto-Tuning for V/f Control**

#### ■ T1-02: Motor Rated Power

Sets the motor rated power according to the motor nameplate value.

No.	Name	Setting Range	Default
T1-02	Motor Rated Power	0.00 to 650.00 kW	Determined by o2-04

**Note:** The display resolution depends on the motor rated power. Drives with a maximum output up to 300 kW will display this value in units of 0.01 kW (two decimal places). Drives with a maximum output greater than 300 kW will display this value in units of 0.1 kW (one decimal place). [Refer to Model Number and Nameplate Check on page 29](#) for details.

### ■ T1-03: Motor Rated Voltage

Sets the motor rated voltage according to the motor nameplate value. If the motor to be operated above its base speed, enter the voltage at base speed here.

For better control precision around rated speed when using a vector control mode, it can be helpful to enter the no-load voltage for the motor here. The motor's "no-load voltage" refers to the voltage needed to operate the motor under no-load conditions at rated speed. The no-load voltage can usually be found in the motor test report available from the manufacturer. If no data is available, enter approximately 90% of the rated voltage printed on the motor nameplate. Note that this might increase the output current reducing the overload margin.

No.	Name	Setting Range	Default
T1-03 </>	Motor Rated Voltage	0.0 to 255.5 V	200.0 V

<1> Values shown here are for 200 V class drives. Double values when using a 400 V class unit.

### ■ T1-04: Motor Rated Current

Sets the motor rated current according to the motor nameplate value. For optimal performance, the motor rated current should be between 50 and 100% of the drive rated current. Enter the current at the motor base speed.

No.	Name	Setting Range	Default
T1-04	Motor Rated Current	10 to 200% of drive rated current	E2-11

### ■ T1-05: Motor Base Frequency

Sets the motor rated frequency according to the motor nameplate value. If a motor with an extended speed range is used or the motor is used in the field weakening area, enter the maximum frequency to E1-04 after Auto-Tuning is complete.

No.	Name	Setting Range	Default
T1-05	Motor Base Frequency	0.0 to 200.0 Hz	50.0Hz

### ■ T1-06: Number of Motor Poles

Sets the number of motor poles according to the motor nameplate value.

No.	Name	Setting Range	Default
T1-06	Number of Motor Poles	2 to 48	4

### ■ T1-07: Motor Base Speed

Used to set the motor rated speed according to the motor nameplate value. If a motor with an extended speed range is used or the motor is used in the field weakening area, enter the speed at base frequency here.

No.	Name	Setting Range	Default
T1-07	Motor Base Speed	0 to 24000 r/min	1450 r/min

### ■ T1-11: Motor Iron Loss

Provides iron loss information for determining the Energy Saving coefficient. T1-11 will first display a value for the motor iron loss that the drive automatically calculated the when motor capacity was entered to T1-02. If the motor test report is available, enter the motor iron loss value listed there.

No.	Name	Setting Range	Default
T1-11	Motor Iron Loss	0 to 65535 W	E2-11

## 4.7 Auto-Tuning

### ◆ Parameter Settings during PM Motor Auto-Tuning: T2

The T2-□□ parameters are used to set the Auto-Tuning input data for PM motor tuning.

#### ■ T2-01: PM Motor Auto-Tuning Mode Selection

Selects the type of Auto-Tuning to be performed. *Refer to Auto-Tuning for Permanent Magnet Motors of OLV control on page 113* for details on different types of Auto-Tuning.

No.	Name	Setting Range	Default
T2-01	PM Motor Auto-Tuning Mode Selection	0 to 2	0

0: PM Motor Parameter Settings

1: PM Stationary Auto-Tuning

2: PM Stationary Auto-Tuning for Stator Resistance

#### ■ T2-02: PM Motor Code Selection

If the drive is operating a Yaskawa PM motor from the SMRA or SSR1 series, enter the motor code for the motor in parameter T2-02. This will automatically set parameters T2-03 through T2-14. If using a specialized motor or one designed by a manufacturer other than Yaskawa, set T2-02 to FFFF. Data from the motor nameplate or the motor test report will then need to be entered as prompted.

Only the designated PM motor codes may be entered. The PM motor codes accepted by the drive will differ by the control mode that has been selected. Refer to *E5: PM Motor Settings on page 176* for motor codes.

No.	Name	Setting Range	Default
T2-02	PM Motor Code Selection	0000 to FFFF	Depending on A1-02 and o2-04

#### ■ T2-03: PM Motor Type

Selects the type of PM motor the drive will operate.

No.	Name	Setting Range	Default
T2-03	PM Motor Type	0, 1	1

0: IPM motor

1: SPM motor

#### ■ T2-04: PM Motor Rated Power

Specifies the motor rated power in kilowatts.

No.	Name	Setting Range	Default
T2-04	PM Motor Rated Power	0.00 to 650.00 kW	Depending on o2-04

**Note:** The display resolution depends on the motor rated power. Drives with a maximum output up to 300 kW will display this value in units of 0.01 kW (two decimal places). Drives with a maximum output greater than 300 kW will display this value in units of 0.1 kW (one decimal place). *Refer to Model Number and Nameplate Check on page 29* for details.

#### ■ T2-05: PM Motor Rated Voltage

Sets the motor rated voltage.

No.	Name	Setting Range	Default
T2-05 <1>	PM Motor Rated Voltage	0.0 to 255.0 V	200.0 V

<1> The setting range and default value shown here is for a 200 V class drive. These values double when using a 400 V class unit.

#### ■ T2-06: PM Motor Rated Current

Enter the motor rated current in amps.

No.	Name	Setting Range	Default
T2-06	PM Motor Rated Current	10% to 200% of the drive rated current.	Depending on o2-04

### ■ T2-07: PM Motor Base Frequency

Enter the motor base frequency in Hz.

**Note:** T2-07 will be displayed when in OLV/PM.

No.	Name	Setting Range	Default
T2-07	PM Motor Base Frequency	0.0 to 200.0 Hz	87.5 Hz

### ■ T2-08: Number of PM Motor Poles

Enter the number of motor poles.

No.	Name	Setting Range	Default
T2-08	Number of PM Motor Poles	2 to 48	6

### ■ T2-10: PM Motor Stator Resistance

Enter the motor stator resistance per motor phase.

No.	Name	Setting Range	Default
T2-10	PM Motor Stator Resistance	0.000 to 65.000 $\Omega$	Depending on T2-02

### ■ T2-11: PM Motor d-Axis Inductance

Enter the d axis inductance per motor phase.

No.	Name	Setting Range	Default
T2-11	PM Motor d-Axis Inductance	0.00 to 600.00 mH	Depending on T2-02

### ■ T2-12: PM Motor q-Axis Inductance

Enter the q axis inductance per motor phase.

No.	Name	Setting Range	Default
T2-12	PM Motor q-Axis Inductance	0.00 to 600.00 mH	Depending on T2-02

### ■ T2-13: Induced Voltage Constant Unit Selection

Selects the units used for setting the induced voltage coefficient.

No.	Name	Setting Range	Default
T2-13	Induced Voltage Constant Unit Selection	0, 1	1

0: mV (r/min)

1: mV (rad/sec)

**Note:** If T2-13 is set to 0, then the drive will use E5-24 (Motor Induction Voltage Constant 2), and will automatically set E5-09 (Motor Induction Voltage Constant 1) to 0.0. If T2-13 is set to 1, then the drive will use E5-09 and will automatically set E5-25 to 0.0.

### ■ T2-14: PM Motor Induced Voltage Constant (Ke)

Enter the motor induced voltage constant (Ke).

No.	Name	Setting Range	Default
T2-14	PM Motor Induced Voltage Constant	0.1 to 2000.0	Depending on T2-02

### ■ T2-15: Pull-In Current Level for PM Motor Tuning

Sets the amount of pull-in current used to tune the d-axis and q-axis inductance. Set as a percentage of the motor rated current.

No.	Name	Setting Range	Default
T2-15	Pull-In Current Level for PM Motor Tuning	0 to 120%	30%

## 4.8 No-Load Operation Test Run

### ◆ No-Load Operation Test Run

This section explains how to operate the drive with the motor decoupled from the load during a test run.

#### ■ Before Starting the Motor

Check the following items before operation:

- Ensure the area around the motor is safe.
- Ensure external emergency stop circuitry is working properly and other safety precautions have been taken.

#### ■ During Operation

Check the following items during operation:

- The motor should rotate smoothly (i.e., no abnormal noise or oscillation).
- The motor should accelerate and decelerate smoothly.

#### ■ No-Load Operation Instructions

The following example illustrates a test run procedure using the digital operator.

**Note:** Before starting the motor, set the frequency reference d1-01 to 6 Hz.

Step			Display/Result
1.	Turn on the power to the drive. The initial display appears.	→	
2.	Press the  key to select LOCAL. The LO/RE light will turn on.	→	 
3.	Press  to give the drive a Run command. RUN will light and the motor will rotate at 6 Hz.	→	 
4.	Ensure the motor is rotating in the correct direction and that no faults or alarms occur.	→	
5.	If there is no error in step 4, press  to increase the frequency reference. Increase the frequency in increments of 10 Hz, verifying smooth operation at all speeds. For each frequency, check the drive output current using monitor U1-03. The current should be well below the motor rated current.		
6.	The drive should operate normally. Press  to stop the motor. RUN flashes until the motor comes to a complete stop.	→	 



## 4.9 Test Run with Load Connected

### ◆ Test Run with the Load Connected

After performing a no-load test run, connect the motor and proceed to run the motor and load together.

#### ■ Notes on Connected Machinery

- Clear the area around the motor.
- The motor should come to a complete stop without problems.
- Connect the load and machinery to the motor.
- Fasten all installation screws properly. Check that the motor and connected machinery are held in place.
- Confirm that the Fast Stop circuit or mechanical safety measures operate correctly.
- Be ready to press the STOP button in case of emergency.

#### ■ Checklist Before Operation

- The motor should rotate in the proper direction.
- The motor should accelerate and decelerate smoothly.

#### ■ Operating the Motor under Loaded Conditions

Test run the application similarly to the no-load test procedure when connecting the machinery to the motor.

- Watch monitor parameter U1-03 during operation to ensure there is no overcurrent.
- If the application permits running the load in the reverse direction, try changing motor direction and the frequency reference while watching for abnormal motor oscillation or vibration.
- Correct any problems that occur with hunting, oscillation, or other control-related issues.

# 4.10 Verifying Parameter Settings and Backing Up Changes

Use the Verify Menu to check all changes to parameter settings as a result of Auto-Tuning. *Refer to Verifying Parameter Changes: Verify Menu on page 104.*

Save the verified parameter settings. Change the access level or set a password to the drive to prevent accidental modification of parameter settings.

### ◆ Backing Up Parameter Values: o2-03

The following procedure saves all parameters settings to drive memory where they can later be recalled. Set o2-03 to “1” to save parameter changes. This saves all parameter settings, and then returns o2-03 to 0. The drive can now “recall” the saved parameters by performing a User Initialization (A1-03 = 1110).

No.	Parameter Name	Description	Setting Range	Default Setting
o2-03	User Parameter Default Value	Lets the user create a set of default settings for a User Initialization. 0: Saved/Not set 1: Set Defaults - Saves current parameter settings as the default values for a User Initialization. 2: Clear All - Clears the currently saved user settings. After saving the user parameter set value, the items of 1110 (User Parameter Initialize) are displayed in A1-03 (User Parameter Default Value).	0 to 2	0
A1-03	Initialize Parameters	Selects a method to initialize the parameters. 0: No Initialize 1110: User Initialization (The user must first program and store desired settings using parameter o2-03) 2220: 2-Wire Initialization (parameter initialized prior to shipment) 3330: 3-Wire Initialization 5550: oPE4 Fault reset	0 to 5550	0

### ◆ Parameter Access Level: A1-01



Setting the Access Level for “Operation only” (A1-01 = 0) allows the user to access parameters A1-□□ and U□-□□ only. Other parameters are not displayed.

Setting the Access Level for “User Parameters” (A1-01 = 1) allows the user to access only the parameters that have been previously saved as User Parameters. This is helpful when displaying only the relevant parameters for a specific application.

No.	Parameter Name	Description	Setting Range	Default
A1-01	Access Level Selection	Selects which parameters are accessible via the digital operator. 0: Operation only. A1-01, A1-04, and A1-06 can be set and monitored, U□-□□ parameters can also be viewed. 1: User Parameters. Only those recently changed among application parameters A2-01 to A2-16 and A2-17 to A2-32 can be set and monitored. 2: Advanced Access Level. All parameters can be set and monitored.	0 to 2	2
A2-01 to A2-32	User Parameters 1 to 32	Parameters selected by the user are saved as User Parameters. This includes recently viewed parameters or parameters specifically selected for quick access. If parameter A2-33 is set to 1, recently viewed parameters will be listed between A2-17 and A2-32. Parameters A2-01 through A2-16 must be manually selected by the user. If A2-33 is set to 0, then recently viewed parameters will not be saved to the group of User Parameters. A2-□□ parameters are now available for manual programming.	b1-01 to o□-□□	—
A2-33	User Parameter Automatic Selection	0: Parameters A2-01 through A2-32 are reserved for the user to create a list of User Parameters. 1: Save history of recently viewed parameters. Recently edited parameters will be saved to A2-17 through A2-32 for quick access. The most recently changed parameter is saved to A2-17. The second most recently changed parameter is saved to A2-18.	0, 1	1

### ◆ Password Settings: A1-04, A1-05

The user can set a password to the drive to restrict access. The password is selected via parameter A1-05. The password must be entered to A1-04 to unlock parameter access (i.e., parameter setting A1-04 must match the value programmed into A1-05). The following parameters cannot be viewed or edited until the value entered to A1-04 correctly matches the value set to A1-05: A1-01, A1-02, A1-03, A1-06, and A2-01 through A2-33.

**Note:** Parameter A1-05 is hidden from view. To display A1-05, access parameter A1-04 and simultaneously press the  key and the  key.

## ◆ Copy Function

Parameter settings can be copied to another drive to simplify parameter restoration or multiple drive setup. The drive supports the following copy options:

- **LED Operator (standard in all models)**

The LED operator used to operate the drive also supports copying, importing, and verifying parameter settings. *Refer to o3: Copy Function on page 249* for details.

- **LCD Operator**

The optional LCD operator also supports copying, importing, and verifying parameter settings. Refer to the manual supplied with the LCD operator for instructions.

- **USB Copy Unit and CopyUnitManager**

The copy unit is an external option connected to the drive to copy parameter settings from one drive and save those settings to another drive. Refer to the manual supplied with the USB Copy Unit for instructions.

The CopyUnitManager is a PC software tool. It allows the user to load parameter settings from the Copy Unit onto a PC, or from the PC onto a Copy Unit. This is useful when managing parameters for various drives or applications. Refer to the manual supplied with the CopyUnitManager for instructions.

- **DriveWizard Plus**

DriveWizard is a PC software tool for parameter management, monitoring, and diagnosis. DriveWizard can load, store, and copy drive parameter settings. For details, refer to Help in the DriveWizard software.

## 4.11 Test Run Checklist

### 4.11 Test Run Checklist

Review the checklist before performing a test run. Check each item that applies.


<input checked="" type="checkbox"/>	No.	Checklist	Page
<input type="checkbox"/>	1	Thoroughly read the manual before performing a test run.	–
<input type="checkbox"/>	2	Turn the power on.	110
<input type="checkbox"/>	3	Set the voltage for the power supply to E1-01.	170

Check the items that correspond to the control mode being used.

**WARNING!** Ensure start/stop and Hardwire Baseblock circuits are wired properly and in the correct state before energizing the drive. Failure to comply could result in death or serious injury from moving equipment. When programmed for 3-Wire control, a momentary closure on terminal S1 may cause the drive to start.

<input checked="" type="checkbox"/>	No.	Checklist	Page
V/f Control (A1-02 = 0)			
<input type="checkbox"/>	4	Select the best V/f pattern according to the application and motor characteristics. Example: Set E1-03 to 1 when using a motor with a rated frequency of 50.0 Hz.	–
<input type="checkbox"/>	5	Perform Rotational Auto-Tuning for V/f Control if using Energy Saving functions.	113
Open Loop Vector Control for PM (A1-02 = 5)			
<input type="checkbox"/>	6	Perform Auto-Tuning as described.	118

Proceed to the following checklist after checking items 4 through 6.

<input checked="" type="checkbox"/>	No.	Checklist	Page
<input type="checkbox"/>	7	The <b>DRV</b> should light after giving a Run command.	–
<input type="checkbox"/>	8	To give a Run command and frequency reference from the digital operator, press  to set to LOCAL. The LO/RE key will light.	106
<input type="checkbox"/>	9	If the motor rotates in the opposite direction during the test run, switch two of the drive output terminals (U/T1, V/T2, W/T3) or change parameter b1-14.	110
<input type="checkbox"/>	10	Set the correct values for the motor rated current (E2-01, E5-03) and motor protection (L1-01) to ensure motor thermal protection.	–
<input type="checkbox"/>	11	If the Run command and frequency reference are provided via the control circuit terminals, set the drive for REMOTE and be sure the LO/RE light is out.	106
<input type="checkbox"/>	12	If the control circuit terminals should supply the frequency reference, select the correct voltage input signal level (0 to 10 V) or the correct current input signal level (4 to 20 mA or 0 to 20 mA).	131
<input type="checkbox"/>	13	Set the proper voltage to terminal A1 and A3 (-10 to +10 V).	131
<input type="checkbox"/>	14	When current input is used, switch the drive's built-in DIP switch S1 from the V-side to I-side. Set the level for current signal used to H3-09 (set "2" for 4 to 20 mA, or "3" for 0 to 20 mA).	131
<input type="checkbox"/>	15	Set the proper current to terminal A2. (-10 to +10 V, 4 to 20 mA or 0 to 20 mA).	131
<input type="checkbox"/>	16	If the frequency reference is supplied via one of the analog inputs, make sure the analog input produces the desired frequency reference. Make the following adjustments if the drive does not operate as expected: Gain adjustment: Set the maximum voltage/current signal and adjust the analog input gain (H3-03 for input A1, H3-11 for input A2, H3-07 for analog input A3) until the frequency reference value reaches the desired value. Bias adjustment: Set the minimum voltage/current signal and adjust the analog input bias (H3-04 for input A1, H3-12 for input A2, H3-08 for analog input A3) until the frequency reference value reaches the desired minimum value.	–

## Parameter Details

---

<b>5.1 A: INITIALIZATION</b> .....	<b>126</b>
<b>5.2 B: APPLICATION.</b> .....	<b>131</b>
<b>5.3 C: TUNING</b> .....	<b>160</b>
<b>5.4 D: REFERENCE SETTINGS</b> .....	<b>165</b>
<b>5.5 E: MOTOR PARAMETERS</b> .....	<b>170</b>
<b>5.6 F: OPTION SETTINGS.</b> .....	<b>179</b>
<b>5.7 H: TERMINAL FUNCTIONS</b> .....	<b>181</b>
<b>5.8 L: PROTECTION FUNCTIONS</b> .....	<b>209</b>
<b>5.9 N: SPECIAL ADJUSTMENTS</b> .....	<b>240</b>
<b>5.10 O: OPERATOR RELATED SETTINGS</b> .....	<b>246</b>
<b>5.11 U: MONITOR PARAMETERS</b> .....	<b>253</b>

## 5.1 A: Initialization

The initialization group contains parameters associated with initial setup of the drive. Parameters involving the display language, access levels, initialization, and password are located in this group.

### ◆ A1: Initialization

#### ■ A1-00: Language Selection

Selects the display language for the digital operator.

**Note:** This parameter is not reset when the drive is initialized using parameter A1-03.

No.	Parameter Name	Setting Range	Default
A1-00	Language Selection	0, 1, 7	7

**Setting 0: English**

**Setting 1: Japanese**

**Setting 7: Chinese**

#### ■ A1-01: Access Level Selection

Allows or restricts access to drive parameters.

No.	Parameter Name	Setting Range	Default
A1-01	Access Level Selection	0 to 2	2

**Setting 0: Operation only**

Access is restricted to parameters A1-01, A1-04, A1-06, and all U monitor parameters.

**Setting 1: User Parameters**

Access to only a specific list of parameters set to A2-01 through A2-32. These User Parameters can be accessed using the Setup Mode of the digital operator.

**Setting 2: Advanced Access Level (A) and Setup Access Level (S)**

All parameters can be viewed and edited.

#### Notes on Parameter Access

- If the drive parameters are password protected by A1-04 and A1-05, parameters A1-00 through A1-03, A1-06, and all A2 parameters cannot be modified.
- If a digital input terminal programmed for “Program lockout” (H1-□□ = 1B) is enabled, parameter values cannot be modified, even if A1-01 is set to 1 or 2.
- If parameters are changed via serial communication, then it will not be possible to edit or change parameters settings with the drive’s digital operator until an Enter command is issued to the drive from the serial communication.

#### ■ A1-02: Control Method Selection

Selects the Control Method (also referred to as the “control mode”) the drive uses to operate the motor.

**Note:** When changing control modes, all parameter settings depending upon the setting of A1-02 will be reset to the default.

No.	Parameter Name	Setting Range	Default
A1-02	Control Method Selection	0, 5	0

## Control Modes for Induction Motors (IM)

### Setting 0: V/f Control for Induction Motors

V/f Control is for simple speed control and multiple motor applications with low demands to dynamic response or speed accuracy. This control mode should be used when the motor parameters are unknown and Auto-Tuning cannot be performed. The speed control range is 1:40.

## Control Modes for Permanent Magnet Motors (SPM or IPM)

### Setting 5: Open Loop Vector Control for PM

Use this mode for variable torque applications and take advantage of the energy saving capabilities of a PM motor. Using this mode, the drive can control an SPM or IPM motor with a speed range of 1:20.

## ■ A1-03: Initialize Parameters

Resets parameters back to the original default values. After initialization, the setting for A1-03 automatically returns to 0.

No.	Parameter Name	Setting Range	Default
A1-03	Initialize Parameters	0, 1110, 2220, 3330, 5550	0

### Setting 1110: User Initialize

Drive parameters are reset to values selected by the user as User Settings. User Settings are stored when parameter o2-03 is set to “1: Set defaults”.

**Note:** A “user-initialization” resets all parameters to a user-defined set of default values that were previously saved to the drive. To clear the user-defined default values, set parameter o2-03 to 2.

### Setting 2220: 2-Wire Initialization

Resets all parameters back to their original default settings with digital inputs S1 and S2 configured as Forward run and Reverse run, respectively. For more on digital input functions, refer to [Setting 40, 41: Forward Run, Reverse Run Command for 2-wire Sequence on page 187](#).

### Setting 3330: 3-Wire Initialization

The drive parameters are returned to factory default values with digital inputs S1, S2, and S5 configured as Run, Stop, and Forward/Reverse respectively. Also refer to digital input functions, [Setting 0: 3-Wire Sequence on page 182](#).

### Setting 5550: oPE04 Reset

If parameters on a certain drive have been edited and then a different terminal block is installed with different settings saved in its built-in memory, an oPE04 error will appear on the display. To use the parameter settings saved to the terminal block memory, set A1-03 to 5550.

## Notes on Parameter Initialization

The parameters shown in [Table 5.1](#) will not be reset when the drive is initialized by setting A1-03 = 2220 or 3330. Although the control mode in A1-02 is not reset when A1-03 is set to 2220 or 3330, it may change when an application preset is selected.

**Table 5.1 Parameters not Changed by Drive Initialization**

No.	Parameter Name
A1-00	Language Selection
A1-02	Control Method Selection
E1-03	V/f Pattern Selection
E5-01	Motor Code Selection (for PM motors)
F6-08	Comm. Parameter Reset
L8-35	Installation Selection
o2-04	Drive/kVA Selection

## ■ A1-04, A1-05: Password and Password Setting

A1-04 is for entering the password when the drive is locked. A1-05 is a hidden parameter used to set the password.

No.	Parameter Name	Setting Range	Default
A1-04	Password	0000 to 9999	0000
A1-05	Password Setting		

## 5.1 A: Initialization

### How to use the Password

The user can set a password for the drive to restrict access. The password is set to A1-05 and must be entered to A1-04 to unlock parameter access. Until the correct password is entered, the following parameters cannot be viewed or edited: A1-01, A1-02, A1-03, A1-06, A1-07 and A2-01 through A2-32.

The instructions below demonstrate how to set a new password. Here, the password set is “1234”. An explanation follows on how to enter the password to unlock the parameters.

**Table 5.2 Setting the Password for Parameter Lock**

Step			Display/Result
1.	Turn on the power to the drive. The initial display appears.	→	
2.	Scroll to the Parameter Setup display and press	→	
3.	Scroll to the right by pressing	→	
4.	Select the flashing digits by pressing	→	
5.	Select A1-04 by pressing	→	
6.	Press the  key while holding down  at the same time. A1-05 will appear. <b>Note:</b> Because A1-05 is hidden, it will not be displayed by simply pressing the  key.	→	 “05” flashes
7.	Press the  key.	→	
8.	Use ,  and  to enter the password.	→	
9.	Press  to save what was entered.	→	
10.	The display automatically returns to the display shown in step 5.	→	












**Table 5.3 Check to see if A1-02 is locked (continuing from step 10 above)**

Step			Display/Result
1.	Press  to display A1-02.	→	 “02” flashes
2.	Press  to display the value set to A1-02.	→	
3.	Press  and , making sure that the setting values cannot be changed.		
4.	Press  to return to the first display.	→	

**Table 5.4 Enter the Password to Unlock Parameters (continuing from step 4 above)**

Step			Display/Result
1.	Press  to enter the parameter setup display.	→	
2.	Press  to select the flashing digits as shown.	→	 “01” flashes
3.	Press  to scroll to A1-04.	→	
4.	Enter the password “1234”.	→	
5.	Press  to save the new password.	→	
6.	Drive returns to the parameter display.	→	



Step			Display/Result
7.	Press  and scroll to A1-02.	→	
8.	Press  to display the value set to A1-02. If the first "0" blinks, parameter settings are unlocked.	→	
9.	Use  and  to change the value if desired (though changing the control mode at this point is not typically done).	→	 OLV/PM
10.	Press  to save the setting, or press  to return to the previous display without saving changes.	→	
11.	The display automatically returns to the parameter display.	→	

**Note:** Parameter settings can be edited after entering the correct password. Performing a 2-wire or 3-wire initialization resets the password to "0000". Reenter the password to parameter A1-05 after drive initialization.

## ■ A1-06: Application Preset

Several Application Presets are available to facilitate drive setup for commonly used applications. Selecting one of these Application Presets automatically programs certain parameters to a new set default values and selects the functions for the I/O terminals that best suit the application. All parameters changed when selecting an Application Preset are also assigned to the list of User Parameters, A2-01 through A2-16. These can be edited more easily in the Setup Mode and provide quicker access by eliminating the need to scroll through multiple menus.

*Refer to Application Selection on page 111* for details on parameter A1-06.

## ■ A1-07: DriveWorksEZ Function Selection

DriveWorksEZ is a software package that can be used to customize the drive functionality or add PLC functionality by the interconnection and configuration of basic software function blocks. The drive performs programs created by the user in 1 ms cycles.

Parameter A1-07 can be used to enable or disable the DriveWorksEZ program inside the drive.

- Note:**
1. If DriveWorksEZ has assigned functions to any multi-function output terminals, those functions will remain set to those terminals even after disabling DriveWorksEZ.
  2. For more information on DriveWorksEZ, contact a Yaskawa representative or the Yaskawa sales department directly.

No.	Parameter Name	Setting Range	Default
A1-07	DriveWorksEZ Function Selection	0 to 2	0

**Setting 0: DWEZ disabled**

**Setting 1: DWEZ enabled**

**Setting 2: Digital input**

If a digital input is programmed for DWEZ enable/disable (H1-□□ = 9F), DWEZ will be enabled when the input is opened.

## ◆ A2: User Parameters

### ■ A2-01 to A2-32: User Parameters 1 to 32

The user can select 32 parameters and assign them to A2-01 through A2-32. This saves time later scrolling through the parameter menu. The list of User Parameters can also track the most recently edited settings and save those parameters to this list.

No.	Parameter Name	Setting Range	Default
A2-01 to A2-32	User Parameters 1 to 32	A1-00 to 04-13	Determined by A1-06 <1>

<1> A1-06 determines how parameters edited by the user are saved to the list of Preferred Parameters, A2-01 through A2-32. Refer to *Application Selection on page 111* for details.

## 5.1 A: Initialization

---

### Saving User Parameters

To save specific parameters to A2-01 to A2-32, first set the access level to allow access to all parameters (A1-02 = 2). Next assign the parameter number to the User Parameters list by entering it into one of the A2-□□ parameters. If A1-01 is then set to 1, the access level can be restricted so that users can only set and refer to the specific parameters saved as User Parameters.

#### ■ A2-33: User Parameter Automatic Selection

A2-33 determines whether or not parameters that have been edited are saved to the User Parameters (A2-17 to A2-32) for quick, easy access.

No.	Parameter Name	Setting Range	Default
A2-33	User Parameter Automatic Selection	0 or 1	Determined by A1-06

#### Setting 0: Do not save list of recently viewed parameters.

To manually select the parameters listed in the User Parameter group, set A2-33 to 0.

#### Setting 1: Save history of recently viewed parameters.

By setting A2-33 to 1, all parameters that were recently edited will be automatically saved to A2-17 through A2-32. A total of 16 parameters are saved with the most recently edited parameter set to A2-17, the second most recently to A2-18, and so on. User Parameters can be accessed using the Setup Mode of the digital operator.

## 5.2 b: Application

### ◆ b1: Operation Mode Selection

#### ■ b1-01: Frequency Reference Selection 1

Use parameter b1-01 to select the frequency reference source 1 for the REMOTE mode.

- Note:**
1. If a Run command is input to the drive but the frequency reference entered is 0 or below the minimum frequency, the RUN indicator LED on the digital operator will light and the STOP indicator will flash.
  2. Press the LO/RE key to set the drive to LOCAL and use the operator keypad to enter the frequency reference.

No.	Parameter Name	Setting Range	Default
b1-01	Frequency Reference Selection 1	0 to 4	1

#### Setting 0: Operator keypad

Using this setting, the frequency reference can be input by:

- switching between the multi-step speed references in the d1-□□ parameters.
- entering the frequency reference on the operator keypad.

#### Setting 1: Terminals (analog input terminals)

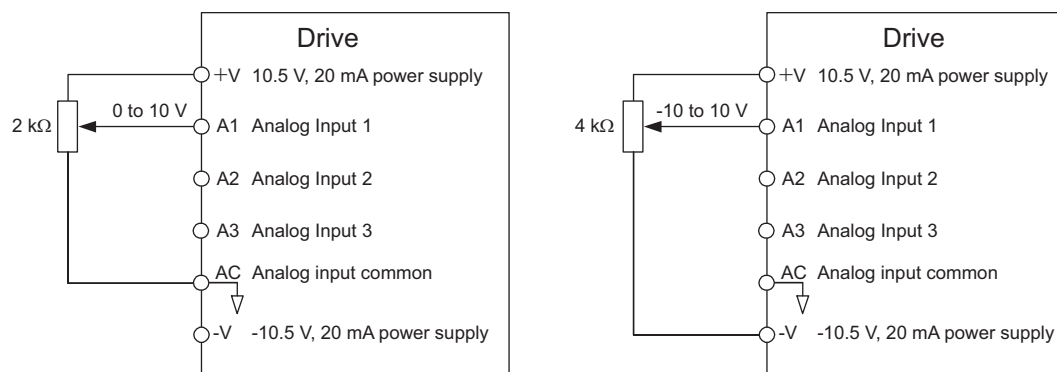
Using this setting, an analog frequency reference can be entered as a voltage or current signal from terminals A1, A2, or A3.

#### Voltage Input

Voltage input can be used at any of the three analog input terminals. Make the settings as described in [Table 5.5](#) for the input used.

**Table 5.5 Analog Input Settings for Frequency Reference Using Voltage Signals**

Terminal	Signal Level	Parameter Settings				Notes
		Signal Level Selection	Function Selection	Gain	Bias	
A1	0 to 10 Vd	H3-01 = 0	H3-02 = 0 (Frequency Reference Bias)	H3-03	H3-04	–
	-10 to +10 Vdc	H3-01 = 1				
A2	0 to 10 Vd	H3-09 = 0	H3-10 = 0 (Frequency Reference Bias)	H3-11	H3-12	Make sure to set DIP switch S1 on the terminal board to “V” for voltage input.
	-10 to +10 Vdc	H3-09 = 1				
A3	0 to 10 Vd	H3-05 = 0	H3-06 = 0 (Frequency Reference Bias)	H3-07	H3-08	Make sure to set DIP switch S4 on the terminal board to “AI”.
	-10 to +10 Vdc	H3-05 = 1				



**Figure 5.1 Setting the Frequency Reference as a Voltage Signal at Terminal A1**

Use the wiring example shown in [Figure 5.1](#) for any other analog input terminals. When using input A2 make sure DIP switch S1 is set for voltage input.

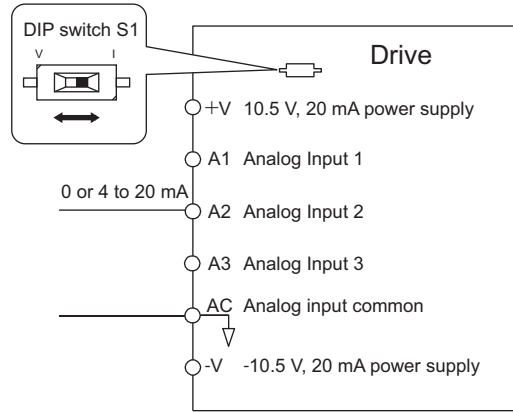
## 5.2 b: Application

### Current Input

Input terminal A2 can accept a current input signal. Refer to [Table 5.6](#) to set terminal A2 for current input.

**Table 5.6 Analog Input Settings for Frequency Reference Using a Current Signal**

Terminal	Signal Level	Parameter Settings			Notes
		Signal Level Selection	Function Selection	Gain	
A2	4 to 20 mA	H3-09 = 2	H3-10 = 0 (Frequency Bias)	H3-11	Make sure to set DIP switch S1 on the terminal board to "I" for current input.
	0 to 20 mA	H3-09 = 3			



**Figure 5.2 Setting the Frequency Reference as a Current Signal to Terminal A2**

DIP switch S1 must first be set for current input.

### Switching between Main/Auxiliary Frequency References

The frequency reference input can be switched between the analog terminals A1, A2, and A3 using multi-step speed inputs. Refer to [Multi-Step Speed Selection on page 165](#) for details on using this function.

### Setting 2: MEMOBUS/Modbus Communications

This setting requires entering the frequency reference via the RS-422/RS-485 serial communications port (control terminals R+, R-, S+, and S-). Refer to [MEMOBUS/Modbus Communications on page 411](#) for instructions.

### Setting 3: Option card

This setting requires entering the frequency reference via an option board plugged into connector CN5-A on the drive control board. Consult the option board manual for instructions on integrating the drive with the communication system.

**Note:** If the frequency reference source is set for an option PCB (b1-01 = 3), but an option board is not installed, an OPE05 Operator Programming Error will be displayed on the digital operator and the drive will not run.

### Setting 4: Pulse Train Input

If b1-01 is set to 4, the frequency reference must be provided by a pulse train signal to terminal RP. Follow the directions below to make sure the pulse signal is working properly.

#### Verifying Pulse Train is Working Properly

- Make sure that b1-04 is set to 4 and H6-01 is set to 0.
- Set the pulse input scaling H6-02 to the pulse train frequency value that equals 100% of the frequency reference.
- Enter a pulse train signal to terminal RP and check if the correct frequency reference is displayed.

### ■ b1-02: Run Command Selection 1

Parameter b1-02 determines the Run command source 1 in the REMOTE mode.

No.	Parameter Name	Setting Range	Default
b1-02	Run Command Selection 1	0 to 3	1

### Setting 0: Digital Operator

This setting requires entering the Run command via the digital operator RUN key and also illuminates the LO/RE indicator on the digital operator.

### Setting 1: Control Circuit Terminal

This setting requires that the Run and Stop commands are entered from the digital input terminals. The following sequences can be used:

- 2-wire sequence 1:  
Two inputs (FWD/Stop-REV/Stop). Initializing the drive by setting A1-03 = 2220, presets the terminals S1 and S2 to these functions. This is the default setting of the drive. Also refer to [Setting 40, 41: Forward Run, Reverse Run Command for 2-wire Sequence on page 187](#).
- 2-wire sequence 2:  
Two inputs (Start/Stop-FWD/REV). Also refer to [Setting 42, 43: Run and Direction Command for 2-wire Sequence 2 on page 188](#).
- 3-wire sequence:  
Three inputs (Start-Stop-FWD/REV). Initialize the drive by setting A1-03 = 3330 presets the terminals S1, S2, and S5 to these functions. Also refer to [Setting 0: 3-Wire Sequence on page 182](#).

### Setting 2: MEMOBUS/Modbus Communications

To issue a Run command via serial communications, set b1-02 to 2 and connect the RS-485/422 serial communication cable to control terminals R+, R-, S+, and S- on the removable terminal block. Refer to [MEMOBUS/Modbus Communications on page 411](#) for instructions.

### Setting 3: Option Card

To issue the Run command via the communication option board, set b1-02 to 3 and plug a communication option board into the CN5-A port on the control PCB. Refer to the manual supplied with the option board for instructions on integrating the drive into the communication system.

**Note:** If b1-02 is set to 3, but an option board is not installed in CN5-A, an oPE05 operator programming error will be displayed on the digital operator and the drive will not run.

## ■ b1-03: Stopping Method Selection

Select how the drive stops the motor when the Run command is removed or when a Stop command is entered.

No.	Parameter Name	Setting Range	Default
b1-03	Stopping Method Selection	0 to 3	0

### Setting 0: Ramp to stop

When the Run command is removed, the drive will decelerate the motor to stop. The deceleration rate is determined by the active deceleration time. The default deceleration time is set to parameter C1-02.

When the output frequency falls below the level set in parameter b2-01, the drive will start DC injection, Zero Speed Control or Short Circuit Braking, depending on the selected control mode. Refer to [b2-01: DC Injection Braking Start Frequency on page 137](#) for details.

### Setting 1: Coast to stop

When the Run command is removed, the drive will shut off its output and the motor will coast (uncontrolled deceleration) to stop. The stopping time is determined by the inertia and the friction in the driven system.

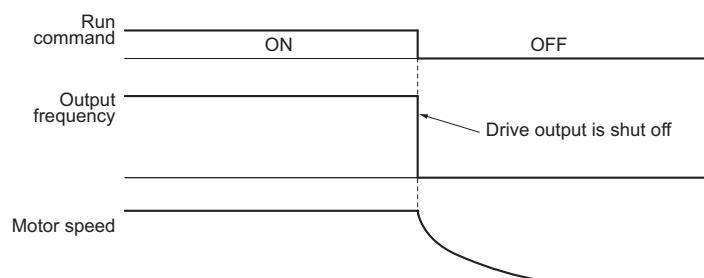


Figure 5.3 Coast to Stop

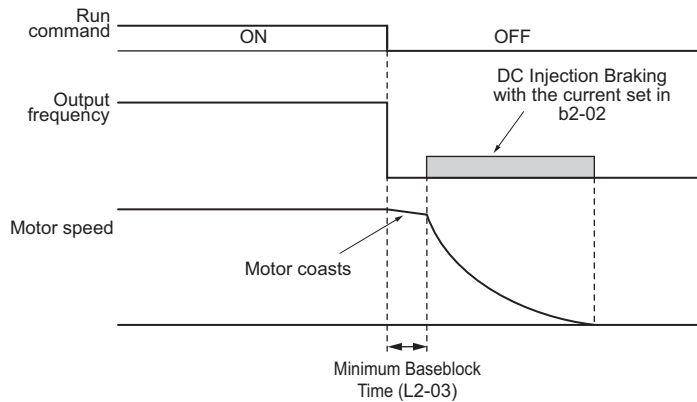
**Note:** After a stop is initiated, any subsequent Run command entered will be ignored until the minimum baseblock time (L2-03) has expired. Do not enter Run command until it has come to a complete stop. To start the motor back up before it has stopped completely, use DC Injection at start (refer to [b2-03: DC Injection Braking Time at Start on page 138](#)) or Speed Search (refer to [b3: Speed Search on page 139](#)).

## 5.2 b: Application

### Setting 2: DC Injection Braking to stop

When the Run command is removed, the drive will enter baseblock (turn off its output) for the minimum baseblock time (L2-03). Once the minimum baseblock time has expired, the drive will brake the motor by injecting DC current into the motor windings. The stopping time is significantly faster than when compared with simply coasting to stop. The level of current used for DC Injection Braking is set by parameter b2-02 (default = 50%).

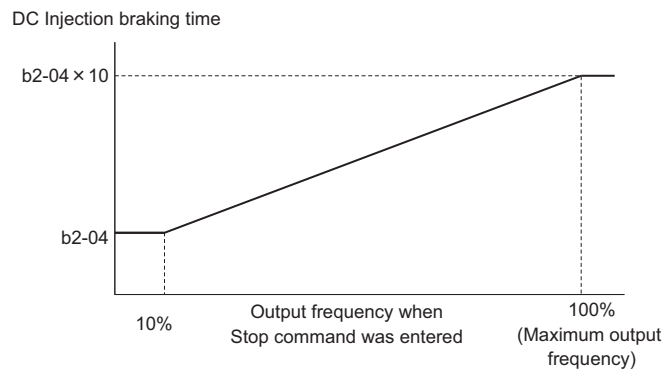
**Note:** This function is not available in the control modes for PM motors (A1-02 = 5, 6, 7).



**Figure 5.4 DC Injection Braking to Stop**

The time for DC Injection Braking is determined by the value set to b2-04 and by the output frequency at the time the Run command is removed. It can be calculated by:

$$\text{DC Injection brake time} = \frac{(b2-04) \times 10 \times \text{Output frequency}}{\text{Max. output frequency (E1-04)}}$$

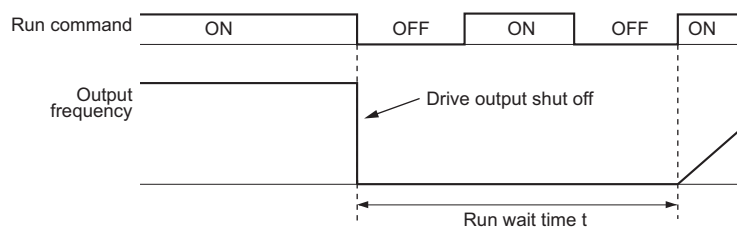


**Figure 5.5 DC Injection Braking Time Depending on Output Frequency**

**Note:** If an overcurrent (oC) fault occurs during DC Injection Braking to stop, lengthen the minimum baseblock time (L2-03) until the fault no longer occurs.

### Setting 3: Coast to Stop with Timer

When the Run command is removed, the drive will turn off its output and the motor will coast to stop. If a Run command is input before the time t (value of C1-02) has expired, the drive will not start. A Run command activated during time t must be cycled after t has expired in order to start the drive.



**Figure 5.6 Coast to Stop with Timer**

The wait time  $t$  is determined by the output frequency when the Run command is removed and by the active deceleration time.

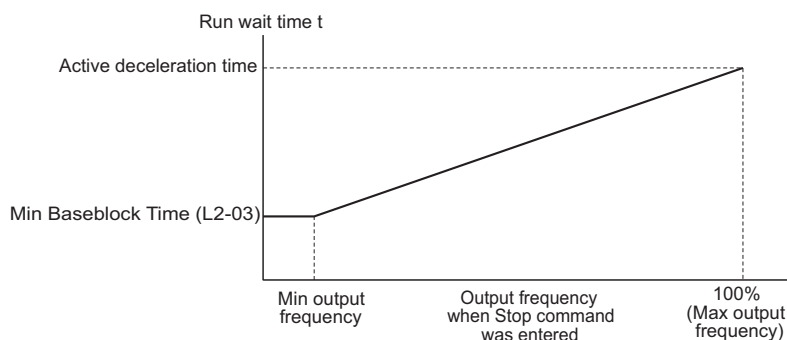


Figure 5.7 Run Wait Time Depending on Output Frequency

### ■ b1-04: Reverse Operation Selection

For some applications, reverse motor rotation is not appropriate and may cause problems (e.g., air handling units, pumps, etc.). Setting parameter b1-04 to 1 instructs the drive to ignore any Reverse run commands.

No.	Parameter Name	Setting Range	Default
b1-04	Reverse Operation Selection	0 or 1	0

#### Setting 0: Reverse operation enabled

Possible to operate the motor in both forward and reverse directions.

#### Setting 1: Reverse operation disabled

Drive disregards a Reverse run command or a negative frequency reference.

### ■ b1-06: Digital Input Reading

This parameter defines how the digital inputs are read. The inputs are acted upon every 1 ms or 2 ms depending upon the setting.

No.	Name	Setting Range	Default
b1-06	Digital Input Reading	0 or 1	1

#### Setting 0: Read once (1 ms scan)

The state of a digital input is read once. If the state has changed, the input command is immediately processed. With this setting the drive responds more quickly to digital inputs, but a noisy signal could cause erroneous operation.

#### Setting 1: Read twice (2 ms scan)

The state of a digital input is read twice. Only if the state does not change during the double reading, the input command is processed. This reading process is slower but more resistant against noisy signals.

### ■ b1-07: LOCAL/REMOTE Run Selection

The drive has three separate control sources that can be switched using digital inputs (H1-□□ = 1 (LOCAL/REMOTE Selection) or 2 (External reference 1/2)) or the LO/RE key on the digital operator. [Refer to Setting 1: LOCAL/REMOTE Selection on page 182](#), [Refer to Setting 2: External Reference 1/2 Selection on page 183](#) and [Refer to o2-01: LO/RE \(LOCAL/REMOTE\) Key Function Selection on page 247](#) for details.

- LOCAL: Digital operator. The digital operator is used to set the frequency reference and Run command.
- REMOTE: External reference 1. The frequency reference and Run command source are set by b1-01 and b1-02.
- REMOTE: External reference 2. The frequency reference and Run command source are set by b1-15 and b1-16.

## 5.2 b: Application

When switching from LOCAL to REMOTE, or between External reference 1 and External reference 2, the Run command may already be present at the location the source was switched to. Parameter b1-07 can be used to determine how the Run command is treated in this case.

No.	Parameter Name	Setting Range	Default
b1-07	LOCAL/REMOTE Run Selection	0 or 1	0

### Setting 0: Run command must be cycled

When the Run command source is different in the old and new source (e.g., the old source was the terminals and the new source is serial communication), and the Run command is active at the new source as the switch over occurs, the drive will not start or will stop operation if it was running before. The Run command has to be cycled at the new source in order to start the drive again.

### Setting 1: Accept Run command at the new source

When the Run command is active at the new source, the drive starts or continues operation if it was running before.

**WARNING!** *The drive may start unexpectedly if switching control sources when b1-07 = 1. Clear all personnel away from rotating machinery and electrical connections prior to switching control sources. Failure to comply may cause death or serious injury.*

### ■ b1-08: Run command selection while in Programming Mode

As a safety precaution, the drive will not normally respond to a Run command input when the digital operator is being used to adjust parameters in the Programming Mode (Verify Menu, Setup Mode, Parameter Settings Mode, and Auto-Tuning Mode). If required by the application, set b1-08 to allow the drive to run while in the Programming Mode.

No.	Parameter Name	Setting Range	Default
b1-08	Run Command Selection while in Programming Mode	0 to 2	0

### Setting 0: Disabled

A Run command is not accepted while the digital operator is in the Programming Mode.

### Setting 1: Enabled

A Run command is accepted in any digital operator mode.

### Setting 2: Prohibit programming during run

It is not possible to enter the Programming Mode as long as the drive output is active. The Programming Mode cannot be displayed during Run.

### ■ b1-11: Drive Delay Time Setting

If a time is set into parameter b1-11, the drive will delay executing any run command until the b1-11 time has expired. During Drive delay time execution, the digital operator will display WrUn.

Both the Alarm and Run indicators will blink while the drive waits to execute the Run command.

No.	Parameter Name	Setting Range	Default
b1-11	Drive Delay Time Setting	0 to 600 s	0

### ■ b1-14: Phase Order Selection

Sets the phase order for drive output terminals U/T1, V/T2, and W/T3.

Switching motor phases will reverse the direction of the motor.

No.	Parameter Name	Setting Range	Default
b1-14	Phase Order Selection	0 or 1	0

### Setting 0: Standard phase order

### Setting 1: Switched phase order



### ■ b1-15: Frequency Reference Selection 2

Refer to b1-01: Frequency Reference Selection 1 on page 131.

No.	Parameter Name	Setting Range	Default
b1-15	Frequency Reference Selection 2	0 to 4	0

### ■ b1-16: Run Command Selection 2

Refer to b1-02: Run Command Selection 1 on page 132.

No.	Parameter Name	Setting Range	Default
b1-16	Run Command Selection 2	0 to 3	0

### ■ b1-17: Run Command at Power Up

This parameter is used to determine whether an external Run command that is active during power up will start the drive or not.

No.	Parameter Name	Setting Range	Default
b1-17	Run Command at Power Up	0 or 1	0

#### Setting 0: Run command at power up is not issued

The Run command has to be cycled to start the drive.

**Note:** For safety reasons, the drive is initially programmed not to accept a Run command at power up (b1-17 = 0). If a Run command is issued at power up, the RUN indicator LED will flash quickly.

#### Setting 1: Run command and power up is issued

If an external Run command is active when the drive is powered up, then the drive will start to operate the motor as soon as it gets ready for operation (i.e., once the internal start up process is complete).

**WARNING!** Sudden Movement Hazard. If b1-17 is set to 1 and an external Run command is active during power up, the motor will begin rotating as soon as the power is switched on. Proper precautions must be taken to ensure that the area around the motor is safe prior to powering up the drive. Failure to comply may cause serious injury.

## ◆ b2: DC Injection Braking and Short Circuit Braking

These parameters determine how the DC Injection Braking, Zero Speed Control, and Short Circuit Braking features operate.

### ■ b2-01: DC Injection Braking Start Frequency

Parameter b2-01 is active when “Ramp to stop” is selected as the stopping method (b1-03 = 0).

No.	Name	Setting Range	Default
b2-01	DC Injection Braking Start Frequency	0.0 to 10.0 Hz	Determined by A1-02

The function triggered by parameter b2-01 depends on the control mode that has been selected.

#### V/f (A1-02 = 0)

For these control modes, parameter b2-01 sets the starting frequency for DC Injection Braking at stop. Once the output frequency falls below the setting of b2-01, DC Injection Braking is enabled for the time set in parameter b2-04.

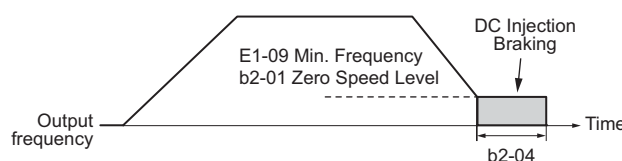


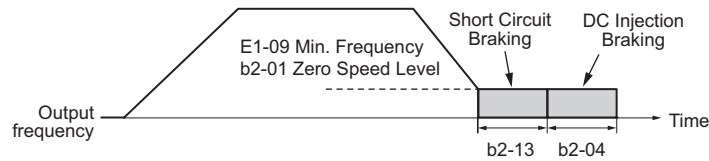
Figure 5.8 DC Injection Braking at Stop for V/f

**Note:** If b2-01 is set to a smaller value than parameter E1-09 (minimum frequency), then DC Injection Braking will begin as soon as the frequency falls to the value set to E1-09.

## 5.2 b: Application

### OLV/PM (A1-02 = 5)

For these control modes, parameter b2-01 sets the starting frequency for Short-Circuit Braking at stop. Once the output frequency falls below the setting of b2-01, Short-Circuit Braking is enabled for the time set in parameter b2-13. If DC Injection Braking time is enabled at stop, then DC Injection Braking is performed for the time set in b2-04 after Short-Circuit Braking is complete.



**Figure 5.9 Short-Circuit Braking at Stop in OLV/PM**

**Note:** If b2-01 is set to a smaller value than parameter E1-09 (minimum frequency), then DC Injection Braking will begin as soon as the frequency falls to the value set to E1-09.

#### ■ b2-02: DC Injection Braking Current

Sets the DC Injection Braking Current as a percentage of the drive rated current. If set larger than 50%, the carrier frequency is automatically reduced to 1 kHz.

No.	Name	Setting Range	Default
b2-02	DC Injection Braking Current	0 to 100%	50%

A DC current can be circulated within the motor windings while the motor is stopped. The current will produce heat within the motor and prevent condensation. b2-02 determines the percentage of drive rated output current that will be used for the motor pre-heat function. This function can be useful in applications where the motor sits for extended periods of time in humid conditions. Motor pre-heating can only be initiated by closing a digital input programmed as a Motor Pre-Heat 1 (H1-□□ = 60). Check with the motor manufacturer to determine the maximum acceptable current level the motor can withstand when stopped. Be sure not to exceed the motor manufacturers recommended level.

#### ■ b2-03: DC Injection Braking Time at Start

Sets the time of DC Injection Braking at start. Used to stop a coasting motor before restarting it or to apply braking torque at start. Disabled when set to 0.00 s.

No.	Name	Setting Range	Default
b2-03	DC Injection Braking Time at Start	0.00 to 10.00 s	0.00 s

**Note:** Before starting an uncontrolled rotating motor (e.g., a fan motor driven by windmill effect), DC Injection or Speed Search should be used to either stop the motor or detect its speed before starting it. Otherwise motor stalling and other faults can occur.

#### ■ b2-04: DC Injection Braking Time at Stop

This parameter sets the DC Injection Braking time at stop. Used to completely stop a motor with high inertia load after ramp down. Increase the value if the motor still coasts by inertia after it should have stopped. Disabled when set to 0.00 s.

No.	Name	Setting Range	Default
b2-04	DC Injection Braking Time at Stop	0.00 to 10.00 s	Determined by A1-02

#### ■ b2-09: Motor Pre-Heat Current 2

b2-09 determines the percentage of motor rated output current that will be used for the motor pre-heat function. This function can be useful in applications where the motor sits for extended periods of time in humid conditions. Motor pre-heating can only be initiated by closing a digital input programmed as a Motor Pre-Heat 2 (H1-□□ = 50).

No.	Name	Setting Range	Default
b2-09	Motor Pre-Heat Current 2	0 to 100%	5

### ■ b2-12: Short Circuit Brake Time at Start

Short Circuit Braking can be used in OLV/PM. By shorting all three motor phases, it produces a braking torque in the motor and can be used to stop a coasting motor before starting it again.

Parameter b2-12 sets the time for Short-Circuit Brake operation at start. Disabled when set to 0.00 s.

No.	Name	Setting Range	Default
b2-12	Short Circuit Brake Time at Start	0.00 to 25.50 s	0.00 s

**Note:** Short Circuit Braking cannot prevent a PM motor from being rotated by an external force. To prevent the load from rotating the motor, use DC Injection.

### ■ b2-13: Short Circuit Brake Time at Stop

The Short Circuit Braking described for parameter b2-12 can also be applied at the end of deceleration in order to completely stop high inertia loads. Short Circuit Braking is initiated for the time set in b2-13 when the output frequency falls below the higher of the values b1-02 and E1-09. Parameter b2-13 sets the time for Short Circuit Braking at stop. Disabled when set to 0.00 s.

No.	Name	Setting Range	Default
b2-13	Short Circuit Brake Time at Stop	0.00 to 25.50 s	0.50 s

### ■ b2-18: Short Circuit Braking Current

Parameter b2-18 sets the current level for Short Circuit Braking operation as a percentage of the motor rated current. Even though a higher current level can be set using b2-18, the Short Circuit Braking current will not be higher than the drive rated current of 120%.

No.	Name	Setting Range	Default
b2-18	Short Circuit Braking Current	0.0 to 200.0%	100.0%

## ◆ b3: Speed Search

The Speed Search function allows the drive to detect the speed of a rotating motor shaft that is driven by external forces (e.g., a fan rotating by windmill effect or motor driven by load inertia). The motor operation can be directly started from the speed detected without needing to stop the machine before.

Example: When a momentary loss of power occurs, the drive output shuts off. This results in a coasting motor. When power returns, the drive can find the speed of the coasting motor and restart it directly.

For PM motors, only parameter b3-01 is needed to enable Speed Search.

For induction motors, the drive offers two types of Speed Search than can be selected by parameter b3-24 (Speed Estimation and Current Detection). Both methods are explained below, then followed by a description of all relevant parameters.

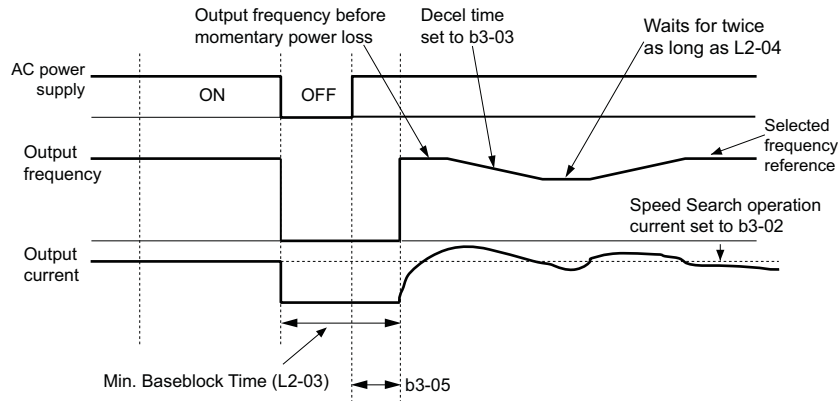
### ■ Current Detection Speed Search (b3-24 = 0)

Current Detection Speed Search is for use with IM motors. Current Detection Speed Search detects the motor speed by looking at motor current. When Speed Search is started it reduces the output frequency starting either from the maximum output frequency or the frequency reference while increasing the output voltage using the time set in parameter L2-04. As long as the current is higher than the level set in b3-02, the output frequency is lowered using the time constant b3-03. If the current falls below b3-02, the drive assumes that the output frequency and motor speed are the same and accelerates or decelerates to the frequency reference.

Be aware that sudden acceleration may occur when using this method of Speed Search with relatively light loads.

The following time chart illustrates how Current Detection Speed Search operates after a momentary power loss (L2-01 must be set to 1 or 2):

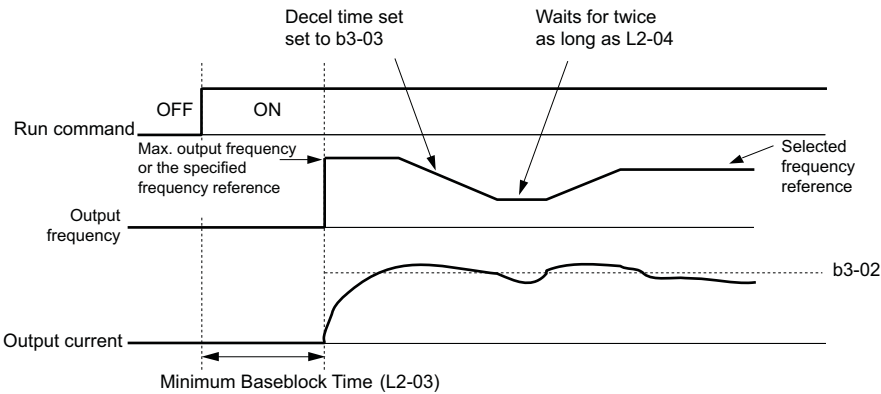
## 5.2 b: Application



**Figure 5.10 Current Detection Speed Search after Power Loss**

**Note:** After power is restored, the drive waits until the time set to b3-05 has passed before performing Speed Search. Thereby the Speed Search may start not at the end of L2-03 but even later.

When Speed Search is applied automatically with the Run command, the drive waits for the minimum baseblock time L2-03 before Speed Search is started. If L2-03 is smaller than the time set in parameter b3-05, then b3-05 is used as the wait time.



**Figure 5.11 Current Detection Speed Search at Start or Speed Search Command by Digital Input**

### Notes on Using Current Detection Type Speed Search

- Shorten the Speed Search deceleration time set to b3-03 if an oL1 fault occurs while performing Current Detection Speed Search.
- Current Detection Speed Search is not available when using Open Loop Vector Control for PM motors.
- Increase the minimum baseblock time set to L2-03 if an overcurrent or overvoltage fault occurs when performing Speed Search after power is restored following a momentary power loss.

### ■ Speed Estimation Type Speed Search (b3-24 = 1)

This method can be used for a single induction motor connected to a drive. It should not be used if the motor is one or more frame sizes smaller than the drive or when using a single drive to operate more than one motor.

Speed Estimation is executed in two steps as described below.

#### Step 1: Back EMF Voltage Estimation

This method is used by Speed Search after short baseblock (e.g., a power loss where the drive's CPU kept running and the Run command was kept active). Here, the drive estimates the motor speed by analyzing the back EMF voltage. It outputs the estimated frequency and increases the voltage using the time constant set in parameter L2-04. After that, the motor is accelerated or decelerated to the frequency reference starting from the detected speed. If there is not enough residual voltage in the motor windings to perform the calculations described above, then the drive will automatically proceed to step 2.

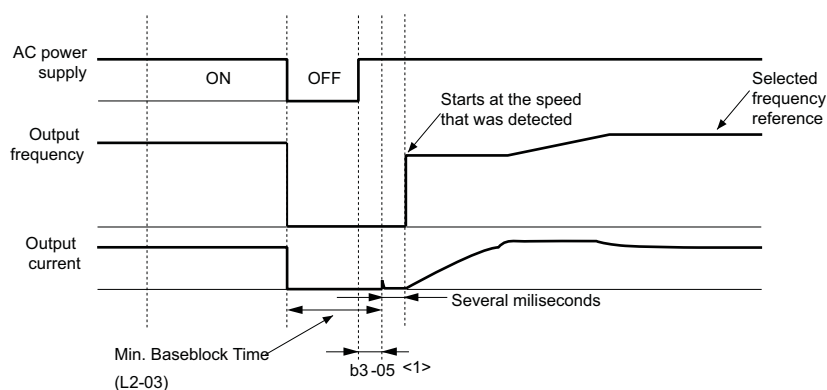


Figure 5.12 Speed Search after Baseblock

- <1> Once AC power is restored, the drive will wait for at least the time set to b3-05. If the power interruption is longer than the minimum baseblock time set to L2-03, the drive will wait until the time set to b3-05 has passed after power is restored before starting Speed Search.

### Step 2: Current Injection

Current Injection is performed when there is not enough residual voltage remaining in the motor. This might occur after longer power losses, when Speed Search is applied with the Run command (b3-01 = 1), or if an External search command is used. It injects the DC current set in b3-06 to the motor and detects the speed by measuring the current feedback. The drive outputs the detected frequency and increases the voltage using the time constant set in parameter L2-04 while looking at the motor current. If the current is higher than the level in b3-02, then the output frequency is reduced. When the current falls below b3-02, the motor speed is assumed to be found and the drive starts to accelerate or decelerate to the frequency reference.

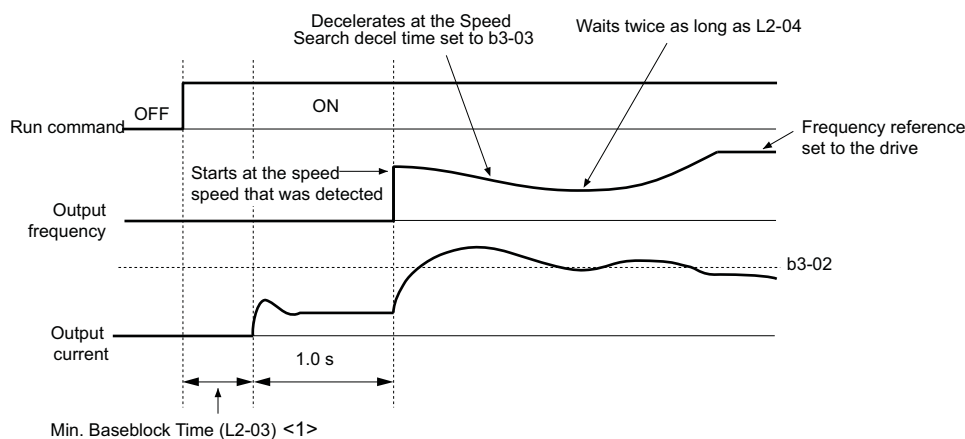


Figure 5.13 Speed Search at Start

- <1> The wait time for Speed Search (b3-05) determines the lower limit.

### Notes on Using Speed Estimation Speed Search

- Rotational Auto-Tuning for V/f Control (T1-01 = 3) needs to be first performed if you plan to use Speed Estimation in V/f Control. Perform Stationary Auto-Tuning for Line-to-Line Resistance (T1-01 = 2) again if there is a change in the cable length between the drive and motor.
- If the application is running multiple motors from the same drive, or if the motor is considerably smaller than the capacity of the drive.
- Speed Estimation may have trouble finding the actual speed if the motor cable is very long. Current Detection should be used in such situations.
- Use Current Detection instead of Speed Estimation when operating motors smaller than 1.5 kW. Speed Estimation can end up stopping smaller motors, as it might not be able to detect the speed or rotation direction of such small motors.
- Short Circuit Braking is recommended instead of Speed Search when using OLV/PM along with a fairly long motor cable.

## 5.2 b: Application

### ■ Activating of Speed Search

Speed Search can be activated as described below. Note that the Speed Search type must be selected in parameter b3-24 independent of the activation method.

1. Automatically activate Speed Search with every Run command. Here, external Speed Search commands are ignored.
2. Activate Speed Search using the digital input terminals.

The following input functions for H1-□□ can be used.

**Table 5.7 Speed Search Activation by Digital Inputs**

Setting	Description	b3-24 = 0	b3-24 = 1
61	External Search Command 1	Closed: Activate Current Detection Speed Search from the maximum output frequency (E1-04).	Activate Speed Estimation Speed Search
62	External Search Command 2	Closed: Activate Current Detection Speed Search from the frequency reference.	

To activate Speed Search by a digital input, the input must always be set together with the Run command, or the Run command must be entered after the Speed Search command is given.

3. After automatic fault restart

When the number of maximum fault restarts in parameter L5-01 is set higher than 0, the drive will automatically perform Speed Search as specified by b3-24 following a fault.

4. After momentary power loss

This mode requires that the Power Loss Ride-Thru function be enabled always or at least enabled during CPU operation (L2-01 = 1 or 2). [Refer to L2-01: Momentary Power Loss Operation Selection on page 214](#)

5. After external baseblock is released

The drive will resume the operation starting with Speed Search if the Run command is present and the output frequency is above the minimum frequency when the Baseblock command is released.

### ■ b3-01: Speed Search Selection at Start

Determines if Speed Search is automatically performed when a Run command is issued or not.

No.	Parameter Name	Setting Range	Default
b3-01	Speed Search Selection at Start	0 or 1	0

#### Setting 0: Disabled

When the Run command is entered, the drive starts operating at the minimum output frequency. If external Speed Search 1 or 2 is already enabled by a digital input, the drive will start operating with Speed Search.

#### Setting 1: Enabled

Speed Search is performed whenever the Run command is entered. The drive begins running the motor once Speed Search is complete.

### ■ b3-02: Speed Search Deactivation Current

Sets the operating current for Speed Search as a percentage of the drive rated current. Normally there is no need to change this setting. If the drive has trouble restarting, try lowering this value.

No.	Name	Setting Range	Default
b3-02	Speed Search Deactivation Current	0 to 200%	Determined by A1-02

**Note:** When parameter A1-02 = 0 (V/f Control) the factory default setting is 120. When parameter A1-02 = 2 (Open Loop Vector) the factory default setting is 100.

### ■ b3-03: Speed Search Deceleration Time

Parameter b3-03 sets the output frequency reduction ramp used by Current Detection Speed Search (b3-24 = 0) and by the Current Injection Method of Speed Estimation (b3-24 = 1). The time entered into b3-03 will be the time to decelerate from maximum frequency (E1-04) to minimum frequency (E1-09).

No.	Name	Setting Range	Default
b3-03	Speed Search Deceleration Time	0.1 to 10.0 s	2.0 s

### ■ b3-04: V/f Gain During Speed Search

During Speed Search, the output voltage calculated from the V/f pattern is multiplied with the value set in parameter b3-04. Changing this setting can be useful in order to reduce the output current during Speed Search.

No.	Name	Setting Range	Default
b3-04	V/f Gain During Speed Search	10 to 100%	Determined by o2-04

### ■ b3-05: Speed Search Delay Time

In cases where an output contactor is used between the drive and the motor, the contactor must be closed before Speed Search can be performed. This parameter can be used to delay the Speed Search operation, giving the contactor enough time to close completely.

No.	Name	Setting Range	Default
b3-05	Speed Search Delay Time	0.0 to 100.0 s	0.2 s

### ■ b3-06: Output Current 1 During Speed Search

Sets the current injected to the motor at the beginning of Speed Estimation Speed Search as a factor of the motor rated current set in E2-01. If the motor speed is relatively slow when the drive starts to perform Speed Search after a long period of baseblock, it may be helpful to increase the setting value. The output current during Speed Search is automatically limited by the drive rated current.

No.	Name	Setting Range	Default
b3-06	Output Current 1 during Speed Search	0.0 to 2.0	Determined by o2-04

**Note:** If Speed Estimation is not working correctly even after adjusting b3-06, try using Current Detection Speed Search instead.

### ■ b3-10: Speed Search Detection Compensation Gain

This parameter sets the gain for the detected motor speed of the Speed Estimation Speed Search. The setting should be increased only if an overvoltage fault occurs when the drive restarts the motor.

No.	Name	Setting Range	Default
b3-10	Speed Search Detection Compensation Gain	1.00 to 1.20	1.05

### ■ b3-14: Bi-Directional Speed Search Selection

Sets how the drive determines the motor rotation direction when performing Speed Estimation Speed Search.

No.	Parameter Name	Setting Range	Default
b3-14	Bi-Directional Speed Search Selection	0 or 1	1

#### Setting 0: Disabled

The drive uses the frequency reference to determine the direction of motor rotation in order to restart the motor.

#### Setting 1: Enabled

The drive detects the motor rotation direction in order to restart the motor.

### ■ b3-17: Speed Search Restart Current Level

A large current can flow into the drive if there is a fairly large difference between the estimated frequency and the actual motor speed when performing Speed Estimation. This parameter sets the current level at which Speed Estimation is restarted, thus avoiding overcurrent and overvoltage problems. Set as a percentage of the drive rated current.

No.	Name	Setting Range	Default
b3-17	Speed Search Restart Current Level	0 to 200%	150%

## 5.2 b: Application

### ■ b3-18: Speed Search Restart Detection Time

Sets the time that the current must be greater than the level set in b3-17 before Speed Search can be restarted.

No.	Name	Setting Range	Default
b3-18	Speed Search Restart Detection Time	0.00 to 1.00 s	0.10 s

### ■ b3-19: Number of Speed Search Restarts

Sets the number of times the drive should attempt to find the speed and restart the motor. If the number of restart attempts exceeds the value set to b3-19, the SEr fault will occur and the drive will stop.

No.	Name	Setting Range	Default
b3-19	Number of Speed Search Restarts	0 to 10	3

### ■ b3-24: Speed Search Method Selection

Sets the Speed Search method used.

No.	Parameter Name	Setting Range	Default
b3-24	Speed Search Method Selection	0 or 1	0

#### Setting 0: Current Detection Speed Search

#### Setting 1: Speed Estimation Speed Search

**Note:** For explanations of the Speed Search methods, *Refer to Current Detection Speed Search (b3-24 = 0) on page 139* and *Refer to Speed Estimation Type Speed Search (b3-24 = 1) on page 140*.

### ■ b3-25: Speed Search Wait Time

Sets the wait time between Speed Search restarts. Increase the wait time if problems occur with overcurrent, overvoltage, or if the SEr fault occurs.

No.	Name	Setting Range	Default
b3-25	Speed Search Wait Time	0.0 to 30.0 s	0.5 s

### ■ b3-27: Start Speed Search Select

Selects a condition to activate Speed Search Selection at Start (b3-01) or External Speed Search Command 1 or 2 from the multi-function input.

No.	Parameter Name	Setting Range	Default
b3-27	Start Speed Search Select	0, 1	0

#### Setting 0: Triggered when a Run Command is Issued (Normal)

#### Setting 1: Triggered when an External Baseblock is Released

## ◆ b4: Delay Timers

The timer function is independent of drive operation and can be used to delay the switching of a digital output triggered by a digital input signal. An on-delay and off-delay can be separately set. The delay timer can help to get rid of chattering switch noise from sensors.

To enable the timer function, a multi-function input must be set to “Timer input” (H1-□□=18) and a multi-function output must be set to “Timer output” (H2-□□=12). One timer can be used only.

### ■ b4-01, b4-02: Timer Function On-Delay, Off-Delay Time

b4-01 sets the on-delay time for switching the timer output. b4-02 sets the off-delay time for switching the timer output.

No.	Name	Setting Range	Default
b4-01	Timer Function On-Delay Time	0.0 to 3000.0 s	0.0 s
b4-02	Timer Function Off-Delay Time	0.0 to 3000.0 s	0.0 s



## ■ Timer Function Operation

When the timer function input closes for longer than the value set in b4-01, the timer output switches on. When the timer function input is open for longer than the value set in b4-02, the timer output function switches off. The following diagram demonstrates the timer function operation.

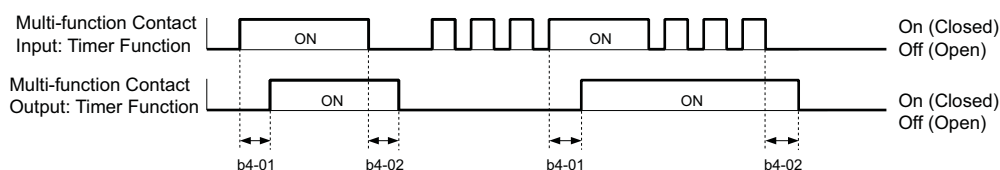


Figure 5.14 Timer Operation

## ◆ b5: PI Control

The drive has a built in PI (Proportional + Integral) controller that can be used for closed loop control of system variables such as pressure, temperature, and so on. The difference between the target and the feedback value (deviation) is fed into the PI controller. The PI controller adjusts the drive output frequency in order to minimize the deviation, providing accurate control of system variables.

### ■ P Control

The output of P control is the product of the deviation and the P gain so that it follows the deviation directly and linearly. With P control, only an offset between the target and feedback remains.

### ■ I Control

The output of I control is the integral of the deviation. It minimizes the offset between target and feedback value that typically remains when pure P control is used. The integral time (I time) constant determines how fast the offset is eliminated.

### ■ PI Operation

To better demonstrate how PI works, the diagram below shows how the PI output changes when the PI input (deviation) jumps from 0 to a constant level.

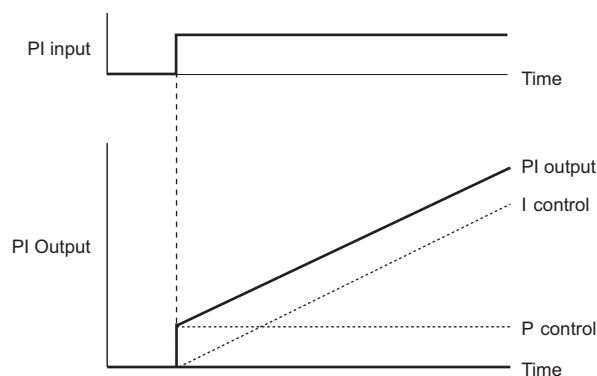


Figure 5.15 PI Operation

### ■ Using PI Control

Applications for PI control are listed in the table below.

Application	Description	Sensors Used
Speed Control	Machinery speed is fed back and adjusted to meet the target value. Synchronous control is performed using speed data from other machinery as the target value	Tachometer
Pressure	Maintains constant pressure using pressure feedback.	Pressure sensor
Fluid Control	Keeps flow at a constant level by feeding back flow data.	Flow rate sensor
Temperature Control	Maintains a constant temperature by controlling a fan with a thermostat.	Thermocoupler, Thermistor

## 5.2 b: Application

### ■ PI Setpoint Input Methods

The PI setpoint input depends on the PI function setting in parameter b5-01.

If parameter b5-01 is set to 1, the frequency reference in b1-01 (or b1-15) or one of the inputs listed in [Table 5.8](#) becomes the PI setpoint.

If b5-01 is set to 3, then the PI setpoint can be input from one of the sources listed in [Table 5.8](#).

**Table 5.8 PI Setpoint Sources**

PI Setpoint Source	Settings
Analog Input A1	Set H3-02 = C
Analog Input A2	Set H3-10 = C
Analog Input A3	Set H3-06 = C
MEMOBUS/Modbus Register 0006H	Set bit 1 in register 000FH to 1 and input the setpoint to register 0006H
Pulse Input RP	Set H6-01 = 2
Parameter b5-19	Set parameter b5-18 = 1 and input the PI setpoint to b5-19

**Note:** A duplicate allocation of the PI setpoint input will result in an oPE alarm.

### ■ PI Feedback Input Methods

Either one feedback signal can be input for normal PI control, or two feedback signals can be input for controlling a differential process value.

#### Normal PI Feedback

The PI feedback signal can be input from one of the sources listed below.

**Table 5.9 PI Feedback Sources**

PI Feedback Source	Settings
Analog Input A1	Set H3-02 = B
Analog Input A2	Set H3-10 = B
Analog Input A3	Set H3-06 = B
Pulse Input RP	Set H6-01 = 1

**Note:** A duplicate allocation of the PI feedback input will result in an oPE alarm.

#### Differential Feedback

The second PI feedback signal for differential feedback can come from the sources listed below. The differential feedback function is automatically enabled when a differential feedback input is assigned.

**Table 5.10 PI Differential Feedback Sources**

PI Differential Feedback Source	Settings
Analog Input A1	Set H3-02 = 16
Analog Input A2	Set H3-10 = 16
Analog Input A3	Set H3-06 = 16

**Note:** A duplicate allocation of the PI differential feedback input will result in an oPE alarm.

PI Block Diagram

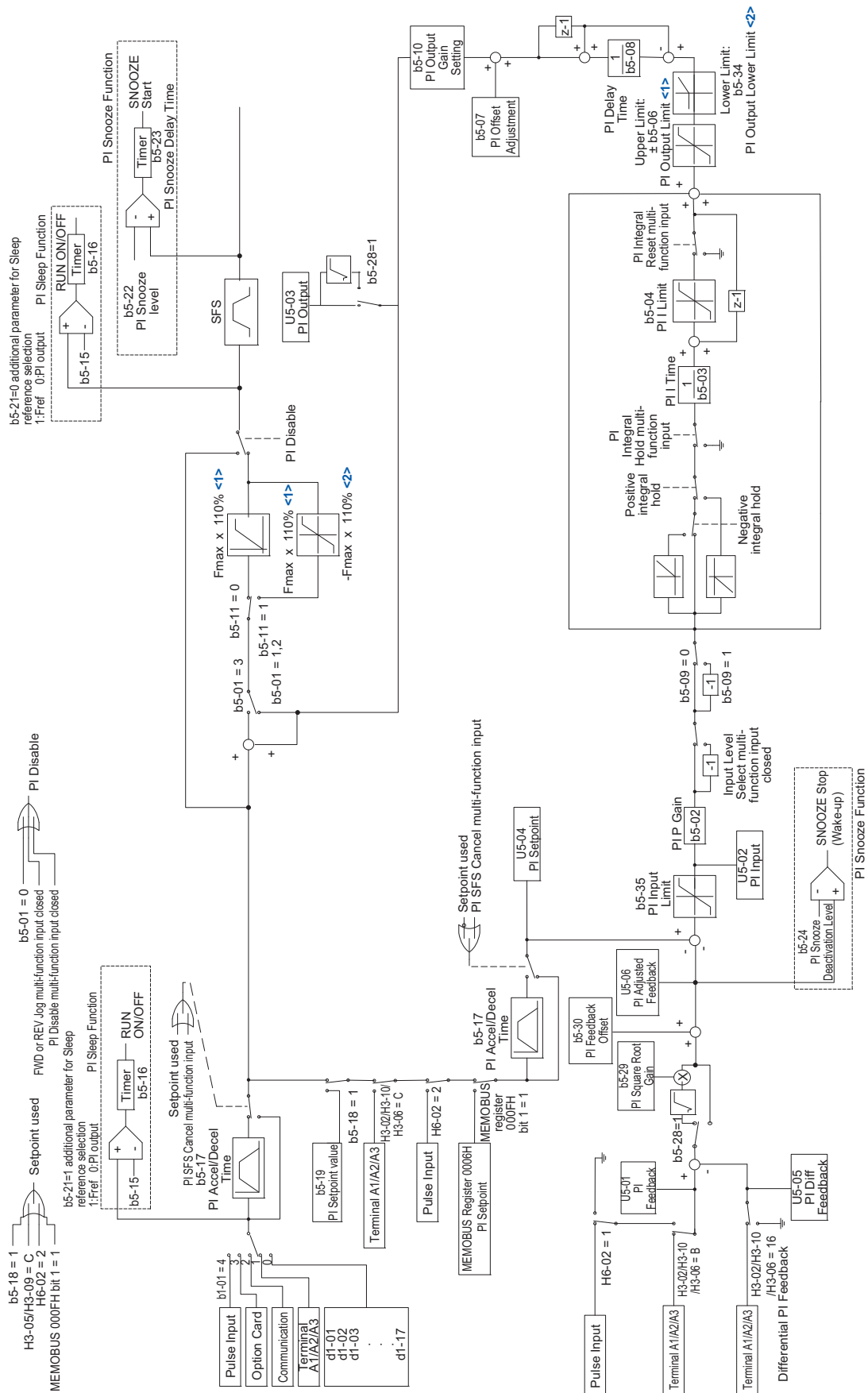


Figure 5.16 PI Block Diagram

## 5.2 b: Application

### ■ b5-01: PI Function Setting

Enables or disables the PI operation and selects the PI operation mode.

No.	Parameter Name	Setting Range	Default
b5-01	PI Function Setting	0, 1, 3	0

#### Setting 0: PI disabled

#### Setting 1: Output frequency = PI output 1

The PI controller is enabled and the PI output builds the frequency reference.

#### Setting 3: Output frequency = frequency reference + PI output 1

The PI controller is enabled and the PI output is added to the frequency reference.

### ■ b5-02: Proportional Gain Setting (P)

Sets the P gain that is applied to the PI input. A large value will tend to reduce the error, but may cause instability (oscillations) if set too high. A low value may allow too much offset between the setpoint and feedback.

No.	Name	Setting Range	Default
b5-02	Proportional Gain Setting (P)	0.00 to 25.00	1.00

### ■ b5-03: Integral Time Setting (I)

Sets the time constant that is used to calculate the integral of the PI input. The smaller the integral time set to b5-03, the faster the offset will be eliminated. If set too short, it can cause overshoot or oscillation. To turn off the integral time, set b5-03 = 0.00.

No.	Name	Setting Range	Default
b5-03	Integral Time Setting (I)	0.0 to 360.0 s	1.0 s

### ■ b5-04: Integral Limit Setting

Sets the maximum output possible from the integral block. Set as a percentage of the maximum frequency (E1-04).

No.	Name	Setting Range	Default
b5-04	Integral Limit Setting	0.0 to 100.0%	100.0%

**Note:** On some applications, especially those with rapidly varying loads, the output of the PI function may show a fair amount of oscillation. To suppress this oscillation, a limit can be applied to the integral output by programming b5-04.

### ■ b5-06: PI Output Limit

Sets the maximum output possible from the entire PI controller. Set as a percentage of the maximum frequency (E1-04).

No.	Name	Setting Range	Default
b5-06	PI Output Limit	0.0 to 100.0%	100.0%

### ■ b5-07: PI Offset Adjustment

Sets the offset added to the PI controller output. Set as a percentage of the maximum frequency.

No.	Name	Setting Range	Default
b5-07	PI Offset Adjustment	-100.0 to 100.0%	0.0%

### ■ b5-08: PI Primary Delay Time Constant

Sets the time constant for the filter applied to the output of the PI controller. Normally, change is not required.

No.	Name	Setting Range	Default
b5-08	PI Primary Delay Time Constant	0.00 to 10.00 s	0.00 s

**Note:** Useful when there is a fair amount of oscillation or when rigidity is low. Set to a value larger than the cycle of the resonant frequency. Increasing this time constant may reduce the responsiveness of the drive.

### ■ b5-09: PI Output Level Selection

Normally a positive PI input (feedback smaller than setpoint) leads to positive PI output. Parameter b5-09 can be used to reverse the sign of the PI controller output signal.

No.	Parameter Name	Setting Range	Default
b5-09	PI Output Level Selection	0 or 1	0

#### Setting 0: Normal Output

A positive PI input causes an increase in the PI output (direct acting).

#### Setting 1: Reverse Output

A positive PI input causes a decrease in the PI output (reverse acting).

### ■ b5-10: PI Output Gain Setting

Applies a gain to the PI output and can be helpful when the PI function is used to trim the frequency reference (b5-01 = 3).

No.	Name	Setting Range	Default
b5-10	PI Output Gain Setting	0.00 to 25.00	1.00

### ■ b5-11: PI Output Reverse Selection

Determines whether a negative PI output reverses the direction of drive operation or not. When the PI function is used to trim the frequency reference (b5-01 = 3), this parameter has no effect and the PI output will not be limited (same as b5-11 = 1).

No.	Parameter Name	Setting Range	Default
b5-11	PI Output Reverse Selection	0 or 1	0

#### Setting 0: Reverse Disabled

Negative PI output will be limited to 0 and the drive output will be stopped.

#### Setting 1: Reverse Enabled

Negative PI output will cause the drive to run in the opposite direction.

### ■ PI Feedback Loss Detection

The PI feedback loss detection function can detect broken sensors or broken sensor wiring. It should be used whenever PI control is enabled to prevent critical machine conditions (e.g., acceleration to max. frequency) caused by a feedback loss.

Feedback loss can be detected in two ways:

- **Feedback Low Detection**

Detected when the feedback falls below a certain level for longer than the specified time. This function is set up using parameters b5-12 to b5-14.

- **Feedback High Detection**

Detected when the feedback rises beyond a certain level for longer than the specified time. This function is set up using parameters b5-12, b5-36, and b5-37.

The following figure explains the working principle of feedback loss detection when the feedback signal is too low. Feedback high detection works in the same way.

## 5.2 b: Application

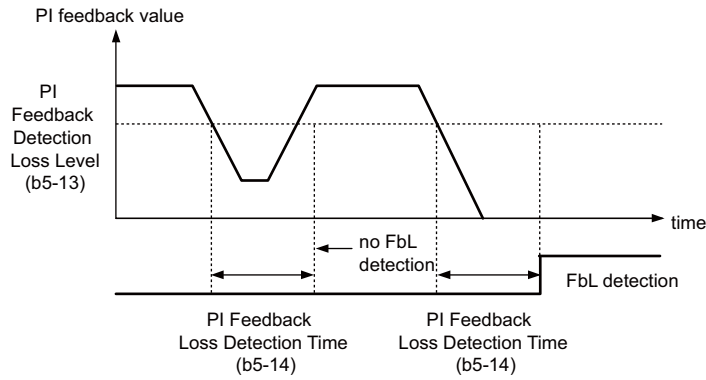


Figure 5.17 PI Feedback Loss Detection

### ■ b5-12: PI Feedback Loss Detection Selection

Enables or disables the feedback loss detection and sets the operation when a feedback loss is detected.

No.	Parameter Name	Setting Range	Default
b5-12	PI Feedback Loss Detection Selection	0 to 5	0

#### Setting 0: Digital Output Only

A digital output set for “PI feedback low” (H2-□□ = 3E) will be triggered if the PI feedback value is below the detection level set to b5-13 for the time set to b5-14 or longer. A digital output set for “PI feedback high” (H2-□□ = 3F) will be triggered if the PI feedback value is beyond the detection level set to b5-36 for longer than the times set to b5-37. Neither a fault nor an alarm is displayed on the digital operator. The drive will continue operation. When the feedback value leaves the loss detection range, the output is reset.

#### Setting 1: Feedback Loss Alarm

If the PI feedback value falls below the level set to b5-13 for longer than the time set to b5-14, a “FBL - Feedback Low” alarm will be displayed and a digital output set for “PI feedback low” (H2-□□ = 3E) will be triggered. If the PI feedback value exceeds the level set to b5-36 for longer than the time set to b5-37, a “FBH - Feedback High” alarm will be displayed and a digital output set for “PI feedback high” (H2-□□ = 3F) will be triggered. Both events trigger an alarm output (H1-□□ = 10). The drive will continue operation. When the feedback value leaves the loss detection range, the alarm and outputs are reset.

#### Setting 2: Feedback Loss Fault

If the PI feedback value falls below the level set to b5-13 for longer than the time set to b5-14, a “FbL - Feedback Low” fault will be displayed. If the PI feedback value exceeds the level set to b5-36 for longer than the time set to b5-37, a “FbH - Feedback High” fault will be displayed. Both events trigger a fault output (H1-□□ = E) and cause the drive to stop the motor.

#### Setting 3: Digital output only, even if PI is disabled by digital input

Same as b5-12 = 0. Detection is still active even if PI is disabled by a digital input (H1-□□ = 19).

#### Setting 4: Feedback loss alarm, even if PI is disabled by digital input

Same as b5-12 = 1. Detection is still active even if PI is disabled by a digital input (H1-□□ = 19).

#### Setting 5: Feedback loss fault, even if PI is disabled by digital input

Same as b5-12 = 2. Detection is still active even if PI is disabled by a digital input (H1-□□ = 19).

### ■ b5-13: PI Feedback Loss Detection Level

Sets the feedback level used for PI feedback low detection. The PI feedback has to fall below this level for longer than the time b5-14 before feedback loss is detected.

No.	Name	Setting Range	Default
b5-13	PI Feedback Low Detection Level	0 to 100%	0%

### ■ b5-14: PI Feedback Loss Detection Time

Sets the time that the PI feedback has to fall below b5-13 before feedback loss is detected.

No.	Name	Setting Range	Default
b5-14	PI Feedback Low Detection Time	0.0 to 25.5 s	1.0 s

### ■ b5-36: PI Feedback High Detection Level

Sets the feedback level used for PI feedback high detection. The PI feedback has to exceed this level for longer than the time b5-37 before feedback loss is detected.

No.	Name	Setting Range	Default
b5-36	PI Feedback High Detection Level	0 to 100%	100%

### ■ b5-37: PI Feedback High Detection Time

Sets the time for that the PI feedback has to exceed b5-36 before feedback loss is detected.

No.	Name	Setting Range	Default
b5-37	PI Feedback High Detection Time	0.0 to 25.5 s	1.0 s

### ■ PI Sleep/Snooze

The PI Sleep function stops the drive when the PI output or the frequency reference falls below the PI Sleep operation level for a certain time. The drive will resume operating once the PI output or frequency reference rises above the PI Sleep operation level for the specified time. An example of PI Sleep operation appears in the figure below.

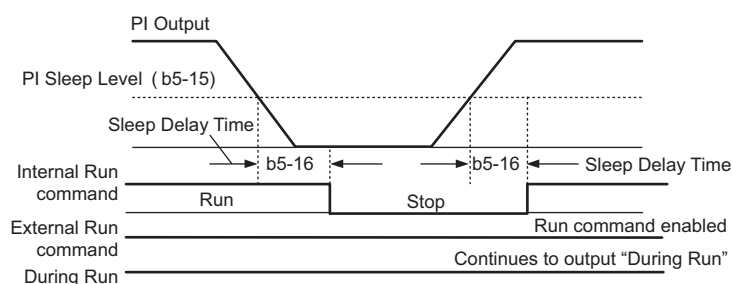


Figure 5.18 PI Sleep Operation

#### Notes on using the PI Sleep function

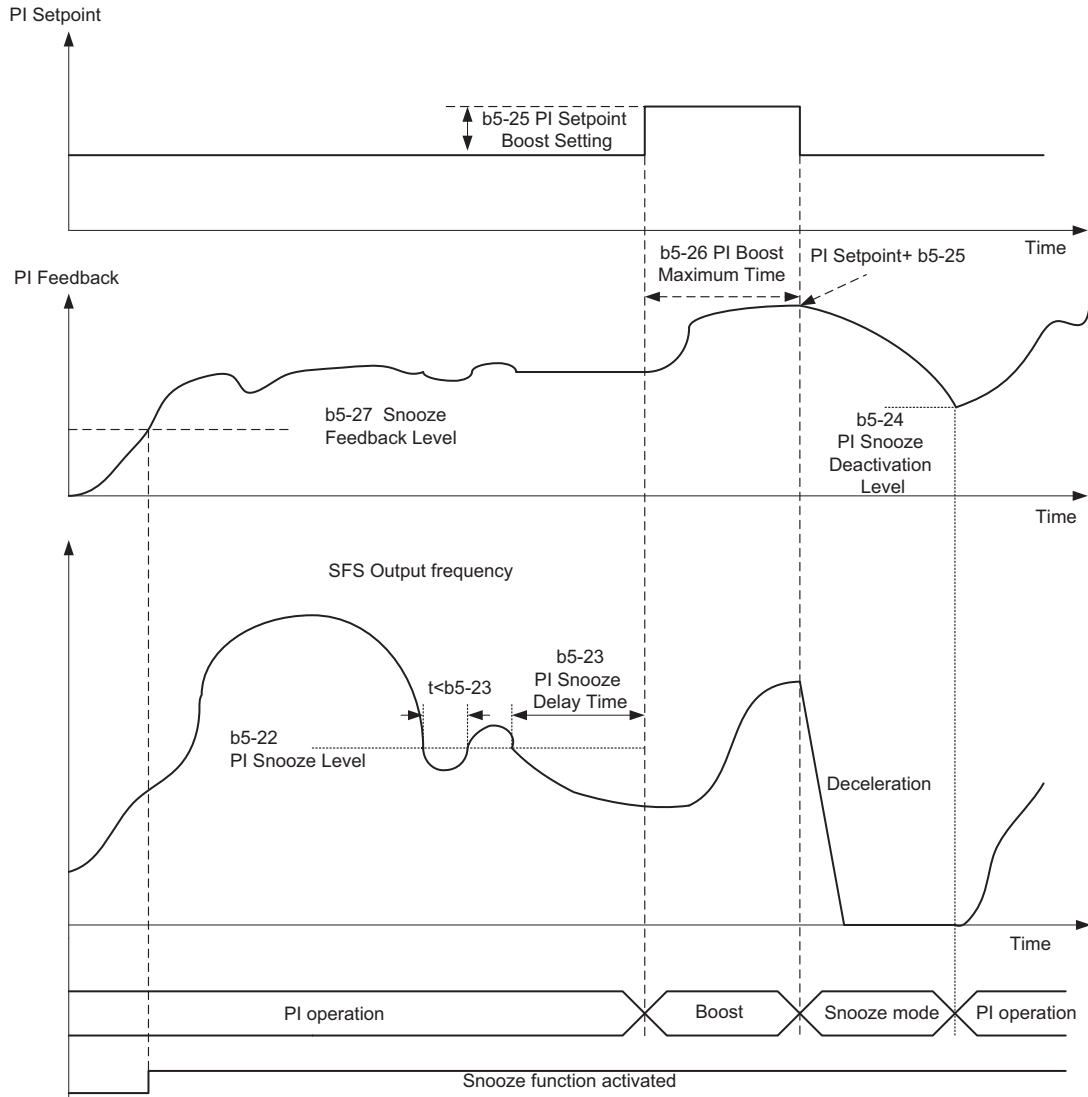
- The PI Sleep function is always active, even if PI control is disabled.
- The PI Sleep function stops the motor according to the stopping method in b1-03.

The PI Snooze Function is a variation on the Sleep Function. The PI Snooze function must be selected by setting parameter b5-21 = "2: Snooze". Once the Snooze Function is selected, the drive monitors the output frequency. If the output frequency drops below the PI Snooze Level (b5-22), and stays below that level for at least the PI Snooze Delay Time (b5-23), the drive output shuts off. This is different from the PI Sleep Function because it is the feedback that must drop below the PI Snooze Deactivation Level (b5-24) before normal drive output will begin again.

Just before the Snooze Function is activated, the PI Setpoint can be temporarily increased to create an overshoot of the intended PI Setpoint. The temporary boost is determined by the PI Boost Setting Level (b5-25). Once the temporary boost level is reached (or the PI Maximum Boost Time (b5-26) is exceeded), the drive output shuts off (snoozes) and the intended PI Setpoint returns. From this point on, the Snooze Function operates normally and the drive output returns when the feedback level drops below b5-24.

## 5.2 b: Application

The parameters necessary that control the PI Sleep/Snooze function are explained below.



### ■ b5-15: PI Sleep Function Start Level

Sets the level that triggers PI Sleep.

The drive goes into Sleep mode if the PI output or frequency reference is smaller than b5-15 for longer than the time set in b5-16. It resumes the operation when the PI output or frequency reference is above b5-15 for longer than the time set in b5-16.

No.	Name	Setting Range	Default
b5-15	PI Sleep Function Start Level	0.0 to 200.0 Hz	0.0 Hz

### ■ b5-16: PI Sleep Delay Time

Sets the delay time to activate or deactivate the PI Sleep function.

No.	Name	Setting Range	Default
b5-16	PI Sleep Delay Time	0.0 to 25.5 s	0.0 s



### ■ b5-17: PI Accel/Decel Time

The PI acceleration/deceleration time is applied on the PI setpoint value.

As the normal acceleration times C1-□□ are applied after the PI output, they reduce the responsiveness of the system and can cause hunting or overshoot and undershoot when the setpoint changes quickly. Using the PI acceleration/deceleration time instead helps to avoid such problems.

The PI acceleration/deceleration time can be canceled using a digital input programmed for “PI SFS cancel” (H1-□□ = 34).

No.	Name	Setting Range	Default
b5-17	PI Accel/Decel Time	0.0 to 6000.0 s	0.0 s

### ■ b5-18: PI Setpoint Selection

Enables or disables parameter b5-19 for PI setpoint.

No.	Parameter Name	Setting Range	Default
b5-18	PI Setpoint Selection	0 or 1	0

#### Setting 0: Disabled

Parameter b5-19 is not used as the PI setpoint.

#### Setting 1: Enabled

Parameter b5-19 is used as PI setpoint.

### ■ b5-19: PI Setpoint Value

Used as the PI setpoint if parameter b5-18 = 1.

No.	Name	Setting Range	Default
b5-19	PI Setpoint Value	0.00 to 100.00%	0.00%

### ■ b5-20: PI Setpoint Scaling

Determines the units that the PI setpoint (b5-19) is set in and displayed. Also determines the units for monitors U5-01 and U5-04.

No.	Parameter Name	Setting Range	Default
b5-20	PI Setpoint Scaling	0 to 3	1

#### Setting 0: Hz

The setpoint and PI monitors are displayed in Hz with a resolution of 0.01 Hz.

#### Setting 1: %

The setpoint and PI monitors are displayed as a percentage with a resolution of 0.01%.

#### Setting 2: r/min

The setpoint and PI monitors are displayed in r/min with a resolution of 1 r/min.

#### Setting 3: User Defined

Parameters b5-38 and b5-39 determine the units and resolution used to display the values the setpoint in b5-19, and PI monitors U1-01 and U1-04.

## 5.2 b: Application

### ■ b5-21: PI Sleep Input Source

Parameter b5-21 selects the sleep function characteristic action.

When b5-21= 1, the sleep function start level (b5-15) is compared to the drive's output (Speed Command after PI block). This is the setting that should be used for open loop control.

It is also possible to have the sleep function start level (b5-15) compared to the drive input or setpoint. For this special application set b5-21 = 0.

When b5-21= 2, a variation of the sleep function called "Snooze" is enabled, see parameter b5-22 to b5-27.

No.	Name	Setting Range	Default
b5-21	PI Sleep input Source	0 to 2	1

0: PI Setpoint

1: SFS input

2: Snooze

### ■ b5-22: PI Snooze Level

Sets the PI Snooze function start level as a percentage of maximum frequency.

No.	Name	Setting Range	Default
b5-22	PI Snooze Level	0 to 100%	0

### ■ b5-23: PI Snooze Delay Time

Sets the PI Snooze function delay time in terms of seconds.

No.	Name	Setting Range	Default
b5-23	PI Snooze Delay Time	0 to 2600 s	0

### ■ b5-24: PI Snooze Deactivation Level

When the PI feedback drops below this level, normal operation starts again. Sets as a percentage of maximum frequency.

No.	Name	Setting Range	Default
b5-24	PI Snooze Wake-Up Level	0 to 100%	0

### ■ b5-25: PI Setpoint Boost Setting

Temporary increase of PI setpoint to create an overshoot of the intended PI setpoint

No.	Name	Setting Range	Default
b5-25	PI Boost Setting Level	0 to 100%	0

### ■ b5-26: PI Maximum Boost Time

Associated with the Snooze Function. In cases where the temporary PI Setpoint (intended PI setpoint + PI Setpoint Boost) cannot be reached within the PI Maximum Boost Time (b5-26), the Setpoint Boost is interrupted and the Drive output is turned off.

No.	Name	Setting Range	Default
b5-26	PI Maximum Boost Time	0 to 2600 s	0

### ■ b5-27: PI Snooze Feedback Level

This is a second method of initiating the Snooze Function. If the PI feedback level exceeds the PI Snooze Feedback Level (b5-27), then the drive output shuts off. Once the PI feedback drops below the PI Snooze Deactivation Level (b5-24) then normal drive and PI operation return. Snooze activates if both b5-22 and b5-27 conditions are met. There is no time delay for deactivation. Sets as a percentage of maximum frequency.

No.	Name	Setting Range	Default
b5-27	PI Snooze Feedback Level	0 to 100%	60

### ■ b5-28: PI Feedback Function Selection

If b5-28 = 1, the square root of the PI feedback is compared to the PI Setpoint in order to determine appropriate drive output to properly regulate the system. This is helpful in cases where the measured feedback is pressure but the PI loop needs to regulate flow.

No.	Name	Setting Range	Default
b5-28	PI Feedback Function Selection	0,1	0

0: Disabled

1: Square Root

### ■ b5-29: PI Square Root Gain

A multiplier applied to the square root of the feedback.

If the PI Function is regulating the flow of a closed loop system by using a pressure feedback, it may be convenient to view the square root of the PI output using monitor U1-37.

No.	Name	Setting Range	Default
b5-29	PI Square Root Gain	0.00 to 2.00	0.00

### ■ b5-30: PI Feedback Offset

Sets PI feedback Offset as a percentage of maximum frequency.

No.	Name	Setting Range	Default
b5-30	PI Feedback Offset	0.00 to 100.00%	0.00

### ■ b5-34: PI Output Lower Limit

Sets the minimum possible PI controller output as a percentage of the maximum output frequency (E1-04). The lower limit is disabled when set to 0.00%

No.	Name	Setting Range	Default
b5-34	PI Output Lower Limit	-100.0 to 100.0%	0.00%

### ■ b5-35: PI Input Limit

Sets the maximum allowed PI input as a percentage of the maximum output frequency (E1-04). Parameter b5-35 acts as a bipolar limit.

No.	Name	Setting Range	Default
b5-35	PI Input Limit	0 to 1000.0%	1000.0%

### ■ b5-38, b5-39: PI Setpoint User Display, PI Setpoint Display Digits

When parameter b5-20 is set to 3, the parameters b5-38 and b5-39 can be used to set a user defined display for the PI setpoint (b5-19) and PI feedback monitors (U5-01, U5-04).

Parameter b5-38 determines the display value when the maximum frequency is output. Parameter b5-39 determines the number of digits. The setting value is equal to the number of decimal places.

No.	Name	Setting Range	Default
b5-38	PI Setpoint User Display	1 to 60000	Determined by b5-20
b5-39	PI Setpoint Display Digits	0 to 3	Determined by b5-20

### ■ b5-40: Frequency Reference Monitor Content During PI

Sets the content of the frequency reference monitor display (U1-01) when PI control is active.

No.	Name	Setting Range	Default
b5-40	Frequency Reference Monitor Content During PI	0 or 1	0

#### Setting 0: Frequency Reference after PI

Monitor U1-01 displays the frequency reference increased or reduced for the PI output.

## 5.2 b: Application

### Setting 1: Frequency Reference

Monitor U1-01 displays the frequency reference value.

#### ■ Fine-Tuning PI

Once PI control parameters have been set, fine-tuning may be required. Follow the directions below.

**Table 5.11 PI Fine Tuning**

Goal	Tuning Procedure	Result
Overshoot must be suppressed	<ul style="list-style-type: none"> <li>Increase the integral time (b5-03)</li> </ul>	
Quickly achieve stability, and some overshoot is permissible	<ul style="list-style-type: none"> <li>Decrease the integral time (b5-03)</li> </ul>	
Suppress long cycle oscillations (longer than the integral time setting)	<ul style="list-style-type: none"> <li>Increase the integral time (b5-03)</li> </ul>	
Suppress short cycle oscillations	<ul style="list-style-type: none"> <li>Reduce the proportional gain (b5-02) or increase the PI primary delay time (b5-08)</li> </ul>	

#### ■ b5-41: PI Unit Selection

Sets the display units in U5-14 and U5-15.

No.	Name	Setting Range	Default
b5-41	PI Unit Selection	0 to 14	0

0: WC (Inch of Water)

1: PSI (lb/Sq inch)

2: GPM (Gallons/min)

3: F (Deg Fahrenheit)

4: CFM (Cubic ft/min)

5: CMH (Cubic M/h)

6: LPH (Liters/h)

7: LPS (Liters/s)

8: Bar (Bar)

9: Pa (Pascal)

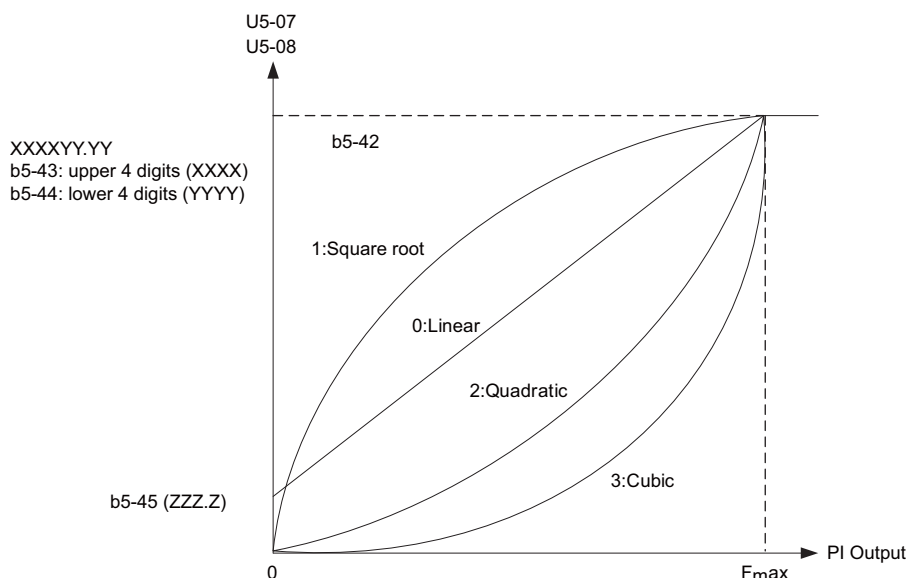
10: C (Deg Celsius)

- 11: Mtr (Meters)
- 12: Ft (Feet)
- 13: LPN (Liters/min)
- 14: CMM (Cubic M/min)

### ■ b5-42: PI Output Monitor Calculation Method

No.	Name	Setting Range	Default
b5-42	PI Output Monitor Calculation Method	0 to 3	0

- 0: Linear unit
- 1: Square root unit
- 2: Quadratic unit
- 3: Cubic unit



### ■ b5-43/b5-44: Custom PI Output Monitor Setting 1/2

U5-14 and U5-15 show Custom PI output. U5-14 shows the upper 4 digits and U5-15 shows the lower 4 digits. It shows 999999.99 maximum. b5-43 and b5-44 is used for setting maximum monitor value at maximum frequency.

No.	Name	Setting Range	Default
b5-43	Custom PI Output Monitor Setting 1	0 to 9999	0
b5-44	Custom PI Output Monitor Setting 2	0.00 to 99.99	0

### ■ b5-45: Custom PI Output Monitor Setting 3

b5-14 shows Custom PI Output. b5-45 is used for setting the minimum display value at 0 speed. This function is effective when b5-42 is set to 0 (Linear unit)

No.	Name	Setting Range	Default
b5-45	Custom PI output monitor setting 3	00.0 to 999.9	0

### ■ b5-46: PI Setpoint Monitor Unit Selection

Sets the Operator display units in U5-01 and U5-04 when b5-20 = 3.

No.	Name	Setting Range	Default
b5-46	PI Setpoint Value Monitor Unit Selection	0 to 14	0

- 0: WC (Inch of Water)
- 1: PSI (lb/Sq inch)
- 2: GPM (Gallons/min)
- 3: F (Deg Fahrenheit)

## 5.2 b: Application

4: CFM (Cubic ft/min)

5: CMH (Cubic M/h)

6: LPH (Liters/h)

7: LPS (Liters/s)

8: Bar (Bar)

9: Pa (Pascal)

10: C (Deg Celsius)

11: Mtr (Meters)

12: Ft (Feet)

13: LPN (Liters/min)

14: CMM (Cubic M/min)

### ■ b5-47: Reverse Operation Selection 2 by PI Output

Determines whether a negative PI output reverses the direction of drive operation. When the PI function is used to trim the frequency reference (b5-01 = 3 or 4), this parameter has no effect and the PI output will not be limited (same as b5-11 = 1).

No.	Name	Setting Range	Default
b5-47	Reverse Operation Selection 2 by PI Output	0 or 1	0

#### Setting 0: Reverse Disabled

Negative PI output will be limited to 0 and the drive output will be stopped.

#### Setting 1: Reverse Enabled

Negative PI output will cause the drive to run in the opposite direction.

## ◆ b8: Energy Saving

The Energy Saving feature improves overall system operating efficiency by operating the motor at its most efficient level.

- Note:**
1. Energy Saving is not designed for applications that experience instantaneous heavy loads or applications that rarely operate with light load conditions.
  2. Energy Saving is mainly designed for applications with variable torque but is not appropriate for applications where the load may suddenly increase.
  3. As the performance of the Energy Saving function strongly depends on the accuracy of the motor data, always perform Auto-Tuning and make sure the motor data has been entered correctly before using this function.

### ■ b8-01: Energy Saving Control Selection

Enables or disables the Energy Saving function.

No.	Parameter Name	Setting Range	Default
b8-01	Energy Saving Control Selection	0 or 1	Determined by A1-02

#### Setting 0: Disabled

#### Setting 1: Enabled

### ■ b8-04: Energy Saving Coefficient Value (V/f)

Parameter b8-04 is used to fine-tune Energy Saving control. The default setting depends on the capacity of the drive. Adjust this setting while viewing the output power monitor (U1-08) and running the drive with a light load.

A low setting results in less output voltage and less energy consumption, but too small a value will cause the motor to stall.

No.	Name	Setting Range	Default
b8-04	Energy Saving Coefficient Value	0.00 to 655.00	Determined by E2-11, and o2-04

- Note:** This default value changes if the motor rated capacity set to E2-11 is changed. The Energy Saving coefficient is set automatically when Auto-Tuning for Energy Saving is performed ([Refer to Auto-Tuning on page 113](#)).

### ■ b8-05: Power Detection Filter Time (V/f)

The Energy Saving function continuously searches out the lowest output voltage in order to achieve minimum output power. Parameter b8-05 determines how often the output power is measured in ms.

Reducing this setting will increase the response time. If the filter time is too short, the motor may become unstable with a lighter load.

No.	Name	Setting Range	Default
b8-05	Power Detection Filter Time	0 to 2000 ms	20 ms

### ■ b8-06: Search Operation Voltage Limit (V/f)

Sets the voltage limit for the optimal output voltage detection of Speed Search as a percentage of the maximum output voltage. During the search operation, the drive will keep the output voltage above this level to prevent motor stalling.

**Note:** If set too low, the motor may stall with a sudden increase to the load. Disabled when b8-06 = 0. Setting this value to 0 does not disable Energy Saving.

No.	Name	Setting Range	Default
b8-06	Search Operation Voltage Limit	0 to 100%	0%

## 5.3 C: Tuning

C parameters are used to set the acceleration and deceleration characteristics, as well as S-curves. Other parameters in this group cover settings for torque compensation, and carrier frequency.

### ◆ C1: Acceleration and Deceleration Times

#### ■ C1-01 to C1-04: Accel, Decel Time 1/2

Two different sets of acceleration and deceleration times can be set in the drive. They can be selected by digital inputs, by the motor selection, or can be switched automatically. Acceleration time parameters always set the time to accelerate from 0 Hz to the maximum output frequency (E1-04). Deceleration time parameters always set the time to decelerate from maximum output frequency to 0 Hz. C1-01 and C1-02 are the default active accel/decel settings.

No.	Parameter Name	Setting Range	Default
C1-01	Acceleration Time 1	0.0 to 6000.0 s	30.0 s
C1-02	Deceleration Time 1		
C1-03	Acceleration Time 2		
C1-04	Deceleration Time 2		

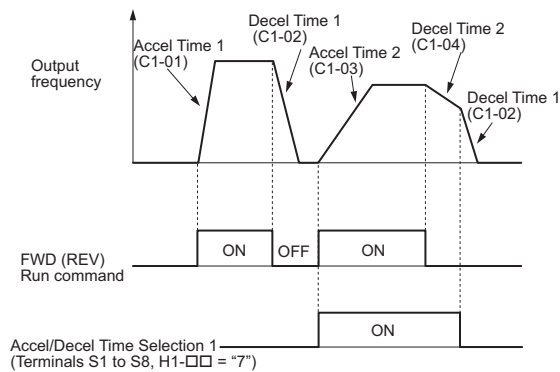
#### Switching Acceleration Times by Digital Input

Accel/decel time 1 are active by default if no input is set. The accel/decel time 2 can be activated by digital inputs (H1-□□ = 7) as explained in [Table 5.12](#).

**Table 5.12 Accel/Decel Time Selection by Digital Input**

Accel/Decel Time Sel. 1 H1-□□ = 7	Active Times	
	Acceleration	Deceleration
0	C1-01	C1-02
1	C1-03	C1-04

[Figure 5.19](#) shows an operation example for changing accel/decel. times. The example below requires that the stopping method be set for “Ramp to stop” (b1-03 = 0).



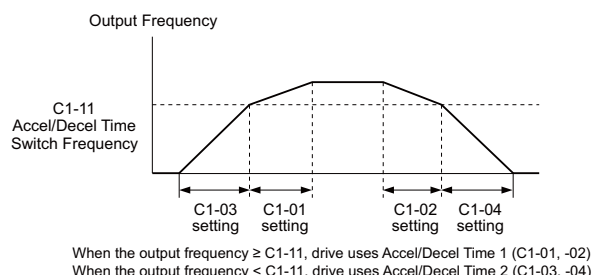
**Figure 5.19 Timing Diagram of Accel/Decel Time Change**



### Switching Accel/Decel Times by a Frequency Level

The drive can switch between different acceleration and deceleration times automatically. The drive will switch from accel/decel time 2 in C1-03 and C1-04 to the default accel/decel time in C1-01 and C1-02 when the output frequency exceeds the frequency level set in parameter C1-11. When it falls below this level, the accel/decel times are switched back. [Figure 5.20](#) shows an operation example.

**Note:** Acceleration and deceleration times selected by digital inputs have priority over the automatic switching by the frequency level set to C1-11. For example, if accel/decel time 2 is selected, the drive will use this time only and not switch from accel/decel time 2 to the selected one.



**Figure 5.20 Accel/Decel Time Switching Frequency**

### ■ C1-11: Accel/Decel Time Switching Frequency

Sets the frequency at which the drive switches between accel/decel time settings. [Refer to Switching Accel/Decel Times by a Frequency Level on page 161.](#)

No.	Parameter Name	Setting Range	Default
C1-11	Accel/Decel Time Switching Frequency	0.0 to 200.0 Hz	0.0 Hz

**Note:** Setting C1-11 to 0.0 Hz disables this function.

### ■ C1-09: Fast Stop Time

Parameter C1-09 will set a special deceleration that is used when certain faults occur or that can be operated by closing a digital input configured as H1-□□ = 15 (N.O. input) or 17 (N.C. input). The input does not have to be closed continuously, even a momentary closure will trigger the Fast Stop operation. Unlike standard deceleration, once the Fast Stop operation is initiated, the drive cannot be restarted until the deceleration is complete, the Fast Stop input is cleared, and the Run command is cycled.

A digital output programmed for “During Fast Stop” (H2-□□ = 4C) will be closed as long as Fast Stop is active.

A Fast Stop can be selected as the action the drive should take when certain faults occur, such as L8-03 (Overheat Pre-Alarm Operation Selection).

No.	Parameter Name	Setting Range	Default
C1-09	Fast Stop Time	0.0 to 6000.0 s	10.0 s

**NOTICE:** Rapid deceleration can trigger an overvoltage fault. When faulted, the drive output shuts off, and the motor coasts. To avoid this uncontrolled motor state and to ensure that the motor stops quickly and safely, set an appropriate Fast Stop time to C1-09.

◆ **C2: S-Curve Characteristics**

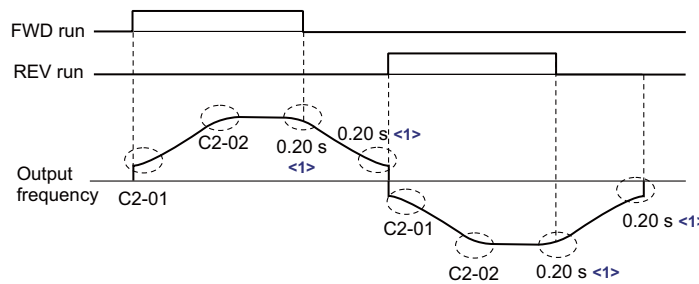
Use S-curve characteristics to smooth acceleration and to minimize abrupt shock to the load. Set S-curve characteristic time during acceleration at start and acceleration at stop. If the STo fault (Hunting Detection) occurs when starting a PM motor, try increasing the value set to C2-01.

■ **C2-01 and C2-02: S-Curve Characteristics**

C2-01 and C2-02 set separate S-curves for each section of the acceleration.

No.	Parameter Name	Setting Range	Default
C2-01	S-Curve Characteristic at Accel Start	0.00 to 10.00 s	Determined by A1-02
C2-02	S-Curve Characteristic at Accel End		0.20 s

Figure 5.21 explains how S-curves are applied.



<1> S-Curve characteristic at Decel Start/End is fixed to 0.20 s.

Figure 5.21 S-Curve Timing Diagram - FWD/REV Operation

Setting the S-curve will increase the acceleration times.

$$\text{Actual accel time} = \text{accel time setting} + (C2-01 + C2-02) / 2$$

◆ **C4: Torque Compensation**

The torque compensation function compensates for insufficient torque production at start-up or when a load is applied.

**Note:** Make sure the motor parameters and V/f pattern are set properly before setting torque compensation parameters.

■ **C4-01: Torque Compensation Gain**

Sets the gain for the torque compensation function.

No.	Parameter Name	Setting Range	Default
C4-01	Torque Compensation Gain	0.00 to 2.50	Determined by A1-02

**Torque Compensation in V/f and OLV/PM:**

The drive calculates the motor primary voltage loss using the output current and the termination resistor value (E2-05 for IM, E5-05 for PM motors) and then adjusts the output voltage to compensate insufficient torque at start or when load is applied. The effects of this voltage compensation can be increased or decreased using parameter C4-01.

**Adjustment**

Although this parameter rarely needs to be adjusted, changing the torque compensation gain in small steps of 0.05 may help in the following situations:

- Increase this setting when using a long motor cable.
- Decrease this setting when motor oscillation occurs.

Adjust C4-01 so that the output current does not exceed the drive rated current.

**Note:** Refrain from adjusting this parameter in OLV/PM. Too high a value can cause overcompensation, resulting in motor oscillation.

## ■ C4-02: Torque Compensation Primary Delay Time

Sets the delay time used for applying torque compensation.

No.	Parameter Name	Setting Range	Default
C4-02	Torque Compensation Primary Delay Time	0 to 60000 ms	Determined by A1-02

### Adjustment

Although C4-02 rarely needs to be changed, adjustments may help in the following situations:

- If the motor vibrates, increase C4-02.
- If the motor responds too slowly to changes in the load, decrease C4-02.

## ◆ C6: Carrier Frequency

### ■ C6-02: Carrier Frequency Selection

Parameter C6-02 sets the switching frequency of the drive's output transistors. Changes to the switching frequency helps lower audible noise and also reduces leakage current.

**Note:** Increasing the carrier frequency above the default value automatically lowers the drive's current rating. *Refer to Rated Current Depending on Carrier Frequency on page 164.*

No.	Parameter Name	Setting Range	Default
C6-02	Carrier Frequency Selection	1 to F </>	Determined by A1-02, o2-04.

<1> The setting range is 1, 2, and F for models CIMR-E□4A0515 to 4A1200.

### Settings:

C6-02	Carrier Frequency	C6-02	Carrier Frequency	C6-02	Carrier Frequency
1	2.0 kHz	5	12.5 kHz	9	Swing PWM 3
2	5.0 kHz	6	15.0 kHz	A	Swing PWM 4
3	8.0 kHz	7	Swing PWM 1	F	User defined (C6-03 to C6-05)
4	10.0 kHz	8	Swing PWM 2		

**Note:** Swing PWM uses a carrier frequency of 2.0 kHz as a base, then applies a special PWM pattern to reduce the audible noise.

### Guidelines for Carrier Frequency Parameter Setup

Symptom	Remedy
Speed and torque are unstable at low speeds	Lower the carrier frequency.
Noise from the drive affects peripheral devices	
Excessive leakage current from the drive	
Wiring between the drive and motor is too long </>	
Audible motor noise is too loud	Increase the carrier frequency or use Swing PWM.

<1> The carrier frequency may need to be lowered if the motor cable is too long. Refer to the table below.

Wiring Distance	Up to 50 m	Up to 100 m	Greater than 100 m
Recommended setting value for C6-02	1 to F (up to 15 kHz)	1 to 2 (up to 5 kHz), 7 (Swing PWM)	1 (up to 2 kHz), 7 (Swing PWM)

**Note:** The maximum cable length is 100 m when A1-02 = 5 (OLV/PM).

### ■ C6-03, C6-04, C6-05: Carrier Frequency Upper Limit, Lower Limit, Proportional Gain

Use these parameters to set a user defined or a variable carrier frequency. To set the upper and lower limits and the carrier frequency proportional gain, first set C6-02 to F.

No.	Parameter Name	Setting Range	Default
C6-03	Carrier Frequency Upper Limit	1.0 to 15.0 kHz </>	Determined by C6-02
C6-04	Carrier Frequency Lower Limit (V/f Control only)	1.0 to 15.0 kHz </>	
C6-05	Carrier Frequency Proportional Gain (V/f Control only)	0 to 99 </>	

<1> The setting range is 1.0 to 5.0 for models CIMR-E□4A0515 to 4A1200.

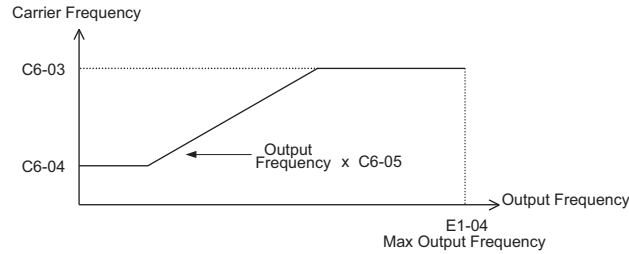
### 5.3 C: Tuning

#### Setting a Fixed User Defined Carrier Frequency

A carrier frequency between the fixed selectable values can be entered in parameter C6-03 when C6-02 is set to F. In V/f Control, parameter C6-04 must also be adjusted to the same value as C6-03.

#### Setting a Variable Carrier Frequency (V/f Control)

In V/f Control, the carrier frequency can be set up to change linearly with the output frequency. To do this, set the upper and lower limits for the carrier frequency and the carrier frequency proportional gain (C6-03, C6-04, C6-05) as shown in [Figure 5.22](#).



**Figure 5.22 Carrier Frequency Changes Relative to Output Frequency**

**Note:** When C6-05 is set lower than 7, C6-04 is disabled and the carrier frequency will be fixed to the value set in C6-03.

#### ■ Rated Current Depending on Carrier Frequency

The tables below show the drive output current depending on the carrier frequency settings.

Use the data in [Table 5.13](#) to linearly calculate output current values for carrier frequencies not listed in the tables.

**Table 5.13 Carrier Frequency and Current Derating**

Three-Phase 200 V Class				Three-Phase 400 V Class			
Model CIMR-E□	Rated Current (A)			Model CIMR-E□	Rated Current (A)		
	2 kHz	8 kHz	15 kHz		2 kHz	8 kHz	15 kHz
2A0004	3.5	3.2	2.56	4A0002	2.1	1.8	1.1
2A0006	6	5	4	4A0004	4.1	3.4	2
2A0008	8	6.9	5.5	4A0005	5.4	4.8	2.9
2A0010	9.6	8	6.4	4A0007	6.9	5.5	3.3
2A0012	12	11	8.8	4A0009	8.8	7.2	4.3
2A0018	17.5	14	11.2	4A0011	11.1	9.2	5.5
2A0021	21	17.5	14	4A0018	17.5	14.8	8.9
2A0030	30	25	20	4A0023	23	18	10.8
2A0040	40	33	26.4	4A0031	31	24	14.4
2A0056	56	47	37.6	4A0038	38	31	18.6
2A0069	69	60	48	4A0044	44	39	23.4
2A0081	81	75	53	4A0058	58	45	27
2A0110	110	85	60	4A0072	72	60	36
2A0138	138	115	81	4A0088	88	75	45
				4A0103	103	91	55

Three-Phase 200 V Class				Three-Phase 400 V Class			
Model CIMR-E□	Rated Current (A)			Model CIMR-E□	Rated Current (A)		
	2 kHz	5 kHz	10 kHz		2 kHz	5 kHz	10 kHz
2A0169	169	145	116	4A0139	139	112	78
2A0211	211	180	144	4A0165	165	150	105
2A0250	250	215	172	4A0208	208	180	126
2A0312	312	283	226	4A0250	250	216	151
2A0360	360	346	277	4A0296	296	260	182
2A0415	415	415	332	4A0362	362	304	213
				4A0414	414	370	—
				4A0515	515	397	—
				4A0675	675	528	—
				4A0930	930	716	—
				4A1200	1200	938	—

## 5.4 d: Reference Settings

The figure below gives an overview of the reference input, selections, and priorities.

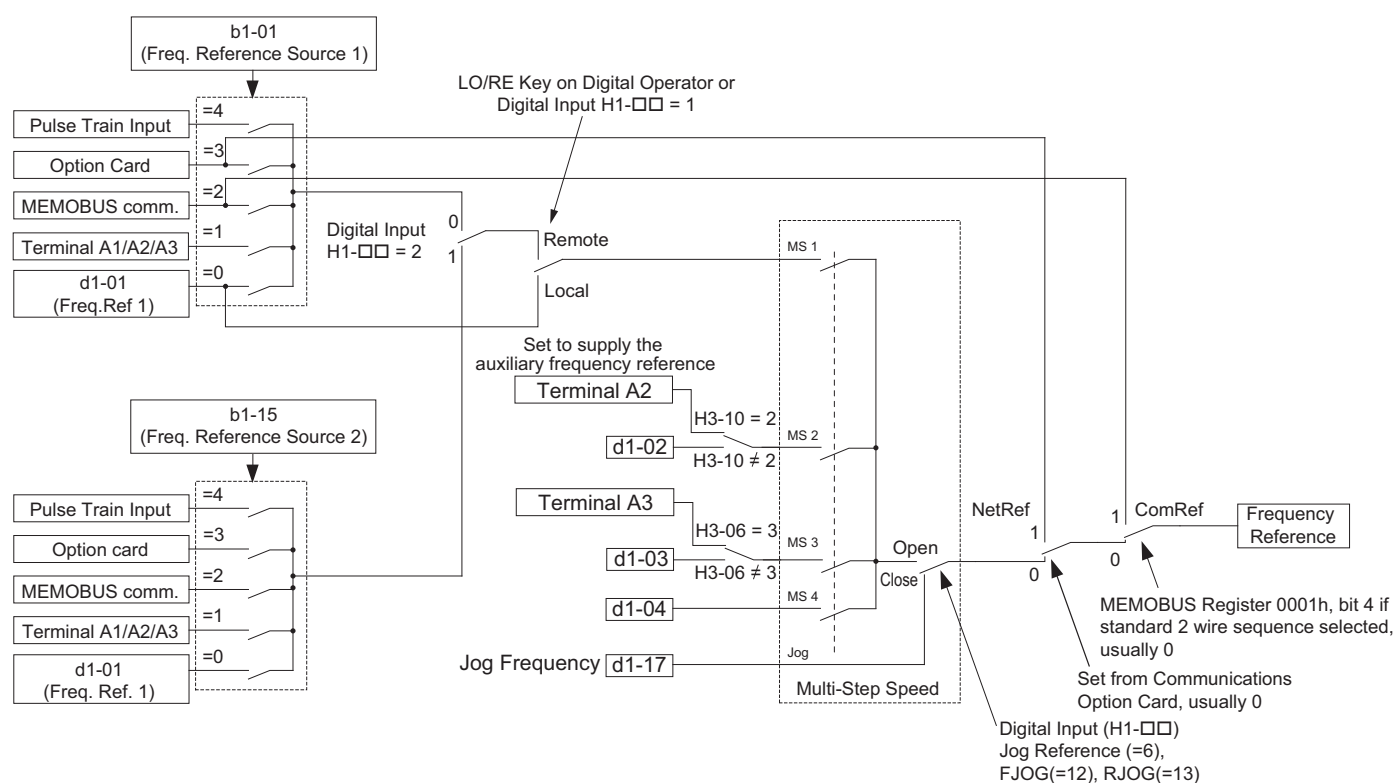


Figure 5.23 Frequency Reference Setting Hierarchy

### ◆ d1: Frequency Reference

#### ■ d1-01 to d1-04 and d1-17: Frequency Reference 1 to 4 and Jog Frequency Reference

Up to 5 preset frequency references (including the Jog reference) can be programmed in the drive. The drive lets the user switch between these frequency references during run by using the digital input terminals. The drive uses the acceleration and deceleration times that have been selected when switching between each frequency reference.

The Jog frequency must be selected by a separate digital input and overrides all other frequency references.

The multi-step speed references 1, 2, and 3 can be provided by analog inputs.

No.	Parameter Name	Setting Range	Default
d1-01 to d1-04	Frequency Reference 1 to 4	0.00 to 200.00 Hz <1> <2>	0.00 Hz <2>
d1-17	Jog Frequency Reference	0.00 to 200.00 Hz <1> <2>	6.00 Hz <2>

<1> The upper limit is determined by the maximum output frequency (E1-04) and upper limit for the frequency reference (d2-01).  
 <2> Setting units are determined by parameter o1-03. The default is "Hz" (o1-03 = 0) in V/f and OLV/PM control modes.

#### Multi-Step Speed Selection

To use several speed references for a multi-step speed sequence, set the H1-□□ parameters to 3 and 4. To assign the Jog reference to a digital input, set H1-□□ to 6.

Notes on using analog inputs as Multi-Step Speed 1 and 2:

- Multi-Step Speed 1  
When setting terminal A1's analog input to Multi-Step Speed 1, set b1-01 to 1, and when setting d1-01 (Frequency Reference 1) to Multi-Step Speed 1, set b1-01 to 0.
- Multi-Step Speed 2  
When setting terminal A2's analog input to Multi-Step Speed 2, set H3-10 (Terminal A2 Function Selection) to 2 (Auxiliary frequency reference 1). When setting d1-02 (Frequency Reference 2) to Multi-Step Speed 2, set H3-10 to 1F (Through mode).

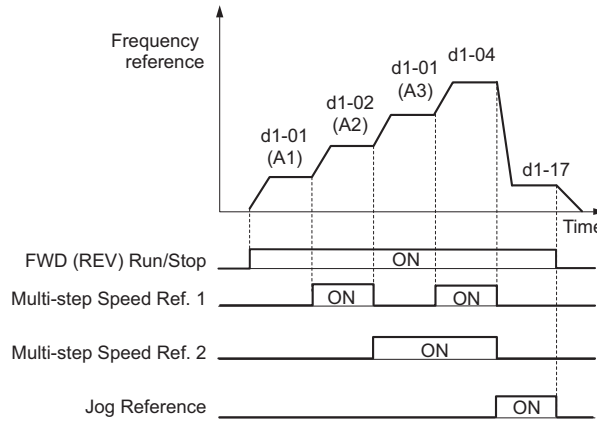
## 5.4 d: Reference Settings

The different speed references can be selected as shown in [Table 5.14](#). [Figure 5.24](#) illustrates the multi-step speed selection.

**Table 5.14 Multi-Step Speed Reference and Terminal Switch Combinations**

Reference	Multi-Step Speed 1 H1-□□=3	Multi-Step Speed 2 H1-□□=4	Jog Reference H1-□□=6
Frequency Reference 1 (set in b1-01)	OFF	OFF	OFF
Frequency Reference 2 (d1-02 or input terminal A1, A2, A3)	ON	OFF	OFF
Frequency Reference 3 (d1-03 or input terminal A1, A2, A3)	OFF	ON	OFF
Frequency Reference 4 (d1-04)	ON	ON	OFF
Jog Frequency Reference (d1-17) </>	-	-	ON

</> The Jog frequency overrides whatever frequency reference is being used.



**Figure 5.24 Preset Reference Timing Diagram**

### ◆ d2: Frequency Upper/Lower Limits

By entering upper or lower frequency limits, the user can keep motor speed from going above or below levels that may cause resonance or equipment damage.

#### ■ d2-01: Frequency Reference Upper Limit

Sets the maximum frequency reference as a percentage of the maximum output frequency. This limit applies to all frequency references.

Even if the frequency reference is set to a higher value, the drive internal frequency reference will not exceed this value.

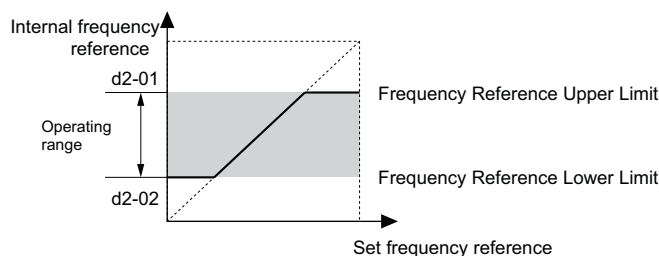
No.	Parameter Name	Setting Range	Default
d2-01	Frequency Reference Upper Limit	0.0 to 110.0%	100.0%

#### ■ d2-02: Frequency Reference Lower Limit

Sets the minimum frequency reference as a percentage of the maximum output frequency. This limit applies to all frequency references.

If a lower reference than this value is entered, the drive will run at the limit set to d2-02. If the drive is started with a lower reference than d2-02, it will accelerate up to d2-02.

No.	Parameter Name	Setting Range	Default
d2-02	Frequency Reference Lower Limit	0.0 to 110.0%	0.0%



**Figure 5.25 Frequency Reference: Upper and Lower Limits**

### ■ d2-03: Master Speed Reference Lower Limit

Unlike frequency reference lower limit (d2-02) that affects the all frequency references wherever they are sourced from (i.e., analog input, preset speed, Jog speed, etc.), the master speed lower limit (d2-03) sets a lower limit that will only affect a frequency reference entered from the analog input terminals (A1, A2, or A3).

Set as a percentage of the maximum output frequency.

**Note:** When lower limits are set to both parameters d2-02 and d2-03, the drive uses the greater of those two values as the lower limit.

No.	Parameter Name	Setting Range	Default
d2-03	Master Speed Reference Lower Limit	0.0 to 110.0%	0.0%

### ◆ d3: Jump Frequency

#### ■ d3-01 to d3-04: Jump Frequencies 1, 2, 3 and Jump Frequency Width

To avoid operating at a speed that causes resonance in driven machinery, the drive can be programmed with three separate Jump frequencies. The Jump frequencies are frequency ranges that the drive will not operate at. If the speed reference falls within a Jump frequency dead band, the drive will clamp the frequency reference just below the dead band and only accelerate past it when the frequency reference rises above the upper end of the dead band.

Setting parameters d3-01 through d3-03 to 0.0 Hz disables the Jump frequency function.

No.	Parameter Name	Setting Range	Default
d3-01	Jump Frequency 1	0.0 to 200.0 Hz	0.0 Hz
d3-02	Jump Frequency 2	0.0 to 200.0 Hz	0.0 Hz
d3-03	Jump Frequency 3	0.0 to 200.0 Hz	0.0 Hz
d3-04	Jump Frequency Width	0.0 to 20.0 Hz	1.0 Hz

Figure 5.26 shows the relationship between the Jump frequency and the output frequency.

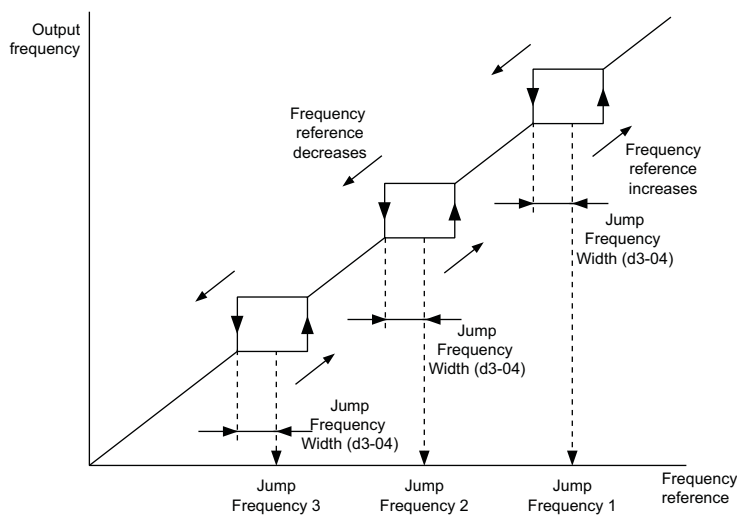


Figure 5.26 Jump Frequency Operation

- Note:**
1. The drive will use the active accel/decel time to pass through the specified dead band range, but will not allow continuous operation in that range.
  2. When setting more than one Jump frequency, make sure that  $d3-01 \geq d3-02 \geq d3-03$ .

### ◆ d4: Frequency Reference Hold Function

#### ■ d4-01: Frequency Reference Hold Function Selection

This parameter is effective when either of the digital input functions listed below is used.

- Accel/decel ramp hold function (H1-□□ = A)
- Up/Down function (H1-□□ = 10/11)

## 5.4 d: Reference Settings

Parameter d4-01 determines whether the frequency reference value is saved when the Stop command is entered or the power supply is shut down.

No.	Parameter Name	Setting Range	Default
d4-01	Frequency Reference Hold Function Selection	0 or 1	0

The operation depends on the function used with parameter d4-01.

### Setting 0: Disabled

- Acceleration hold

The hold value will be reset to 0 Hz when the Stop command is entered or the drive power is switched off. The active frequency reference will be the value the drive uses when it restarts.

- Up/Down

The frequency reference value will be reset to 0 Hz when the Stop command is entered or the drive power is switched off. The drive will start from 0 Hz when it is turned back on again.

### Setting 1: Enabled

- Acceleration hold

The last hold value will be saved when the Run command or the drive power is switched off. The drive will use the value that was saved as the frequency reference when it restarts. The multi-function input terminal set for “Accel/decel ramp hold” (H1-□□ = A) must be enabled the entire time, or else the hold value will be cleared when the power is switched on.

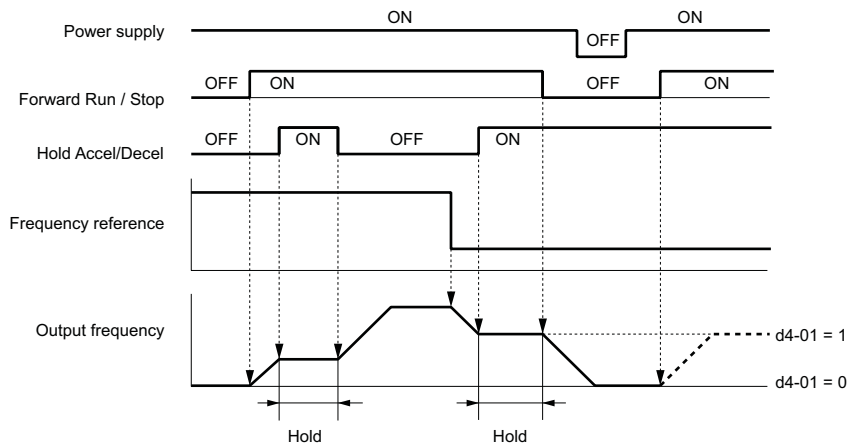


Figure 5.27 Frequency Reference Hold with Accel/Decel Hold Function

- Up/Down

The frequency reference value will be saved when the Run command or the drive power is switched off. The drive will use the frequency reference that was saved when it restarts.

### Clearing the Value that was Saved

Depending on which function is used, the frequency reference value that was saved can be cleared by:

- Releasing the input programmed for Acceleration hold.
- Setting an Up or Down command while no Run command is active.

### ■ d4-10: Up/Down Frequency Reference Limit Selection

Selects how the lower frequency limit is set when the Up/Down function is used. Refer to [Setting 10, 11: Up, Down Command on page 184](#) for details on the Up/Down function in combination with frequency reference limits.

No.	Parameter Name	Setting Range	Default
d4-10	Up/Down Frequency Reference Limit Selection	0 or 1	0

### Setting 0: Lower Limit is Determined by d2-02 or Analog Input

The lower frequency reference limit is determined by the higher value of either parameter d2-02 or an analog input (A1, A2, A3) that is programmed for “Frequency bias”.

**Note:** For example, if the command to switch the external reference (H1-□□ = 2) is used to switch between the Up/Down function and an analog input as the reference source, then the analog value would become the lower reference limit when the Up/Down command is active. Change d4-10 to 1 to make the Up/Down function independent of the analog input value.



**Setting 1: Lower Limit is Determined by Parameter d2-02**

Only parameter d2-02 sets the lower frequency reference limit.

**◆ d6: Field Weakening and Field Forcing****Field Weakening**

The Field Weakening function reduces the output voltage to a pre-defined level in order to reduce the energy consumption of the motor. It can be activated using a digital input programmed for H1-□□ = 63. Field Weakening should only be used with a known and unchanging light load condition. Use the Energy Saving function (b8-□□ parameters) when Energy Saving for various different load conditions is required.

**Field Forcing**

The Field Forcing function compensates the delaying influence of the motor time constant when changing the excitation current reference. Field Forcing can improve the motor responsiveness. It is ineffective during DC Injection Braking.

**■ d6-01: Field Weakening Level**

Sets the level to what the output voltage is reduced when Field Weakening is activated. Set as percentage of the maximum output voltage.

No.	Parameter Name	Setting Range	Default
d6-01	Field Weakening Level	0 to 100%	80%

**■ d6-02: Field Weakening Frequency Limit**

Sets the minimum output frequency for that field weakening can be activated. For frequencies below d6-02, Field Weakening cannot be activated.

No.	Parameter Name	Setting Range	Default
d6-02	Field Weakening Frequency Limit	0 to 200.0 Hz	0.0 Hz

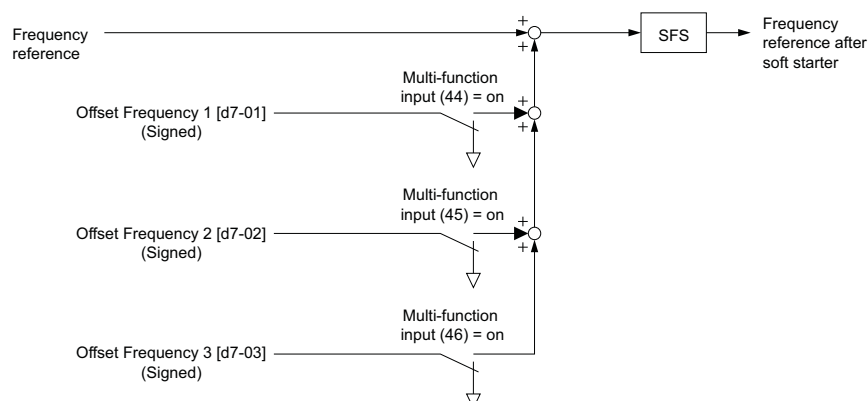
**◆ d7: Offset Frequency****■ d7-01 to d7-03: Offset Frequency 1 to 3**

Three different offset values can be added to the frequency reference. They can be selected using digital inputs programmed for Offset frequency 1, 2, and 3 (H1-□□ = 44, 45, 46). The selected offset values are added together if multiple inputs are closed at the same time.

**Note:** This function can be used to replace the “Trim Control” function (H1-□□ = 1C, 1D) of earlier Yaskawa drives.

No.	Parameter Name	Setting Range	Default
d7-01	Offset Frequency 1	-100.0 to 100.0%	0%
d7-02	Offset Frequency 2	-100.0 to 100.0%	0%
d7-03	Offset Frequency 3	-100.0 to 100.0%	0%

*Figure 5.28* illustrates the Offset frequency function.



**Figure 5.28 Offset Frequency Operation**

## 5.5 E: Motor Parameters

E parameters cover V/f pattern and motor data settings.

### ◆ E1: V/f Pattern

#### ■ E1-01: Input Voltage Setting

Set the input voltage parameter to the nominal voltage of the AC power supply. This parameter adjusts the levels of some protective features of the drive (overvoltage, Stall Prevention, etc.).

**NOTICE:** Set parameter E1-01 to match the input voltage of the drive. Drive input voltage (not motor voltage) must be set in E1-01 for the protective features to function properly. Failure to set the correct drive input voltage will result in improper drive operation.

No.	Parameter Name	Setting Range	Default
E1-01 <1>	Input Voltage Setting	155 to 255 V	200 V

<1> The setting range and default value shown here are for 200 V class drives. Double this for 400 V class units.

#### E1-01 Related Values

The input voltage setting determines the undervoltage detection level as well as DC bus levels used by the KEB function and the overvoltage suppression function.

Voltage	Setting Value of E1-01	(Approximate Values)		
		Uv Detection Level (L2-05)	Desired DC Bus Voltage during KEB (L2-11)	ov Suppression / Stall Prevention Level (L3-17)
200 V Class	All settings	190 V	260 V	375 V
	setting ≥ 400 V	380 V	500 V	750 V
400 V Class	setting ≥ 400 V	380 V	500 V	750 V
	setting < 400 V	350 V	460 V	750 V

**Note:** The braking transistor operation levels are valid for the drive internal braking transistor. If an external CDBR braking chopper is used, refer to the instruction manual of that unit.

#### ■ V/f Pattern Settings (E1-03)

The drive uses the V/f pattern that has been set to adjust the output voltage relative to the frequency reference. There are 15 different preset V/f patterns (setting 0 to E) to select from, each with varying voltage profiles, saturation levels (frequency at which maximum voltage is reached), and maximum frequencies. Additionally, one custom V/f pattern is available (setting F). The custom V/f pattern requires the user to create the pattern using parameters E1-04 through E1-10.

#### ■ E1-03: V/f Pattern Selection

The user can select the V/f pattern for the drive and motor from 15 predefined patterns, or create a custom V/f pattern.

No.	Parameter Name	Setting Range	Default
E1-03	V/f Pattern Selection	0 to F <1>	F <2>

<1> Parameter setting value is not reset to the default value during drive initialization (A1-03).

<2> Settings 0 through E are not available when using any of the vector control modes.

**Setting a Predefined V/f Pattern (Setting 0 to F)**

Choose the V/f pattern that best meets the application demands from the table below. These settings are available only in V/f Control modes. Set the correct value to E1-03. Parameters E1-04 to E1-13 can only be monitored, not changed.

- Note:**
1. Setting an improper V/f pattern may result in low motor torque or increased current due to overexcitation.
  2. Parameter E1-03 is not reset when the drive is initialized.

**Table 5.15 Predefined V/f Patterns**

Setting	Specification	Characteristic	Application
0	50 Hz	Constant torque	For general purpose applications. Torque remains constant regardless of changes to speed.
1	60 Hz		
2	60 Hz (with 50 Hz base)		
3	72 Hz (with 60 Hz base)		
4	50 Hz 2	Derated torque	For fans, pumps, and other applications where the required torque changes as a function of the speed.
5	50 Hz 1		
6	60 Hz 1		
7	60 Hz 2	High starting torque	Select high starting torque when: <ul style="list-style-type: none"> <li>• Wiring between the drive and motor exceeds 150 m</li> <li>• A large amount of starting torque is required</li> <li>• An AC reactor is installed</li> </ul>
8	50 Hz, mid starting torque		
9	50 Hz, high starting torque		
A	60 Hz, mid starting torque		
B	60 Hz, high starting torque		
C	90 Hz (with 60 Hz base)	Constant output	Output voltage is constant when operating at greater than 60 Hz.
D	120 Hz (with 60 Hz base)		
E	180 Hz (with 60 Hz base)		
F </>	60 Hz	Constant torque	For general purpose applications. Used for general applications requiring constant torque.

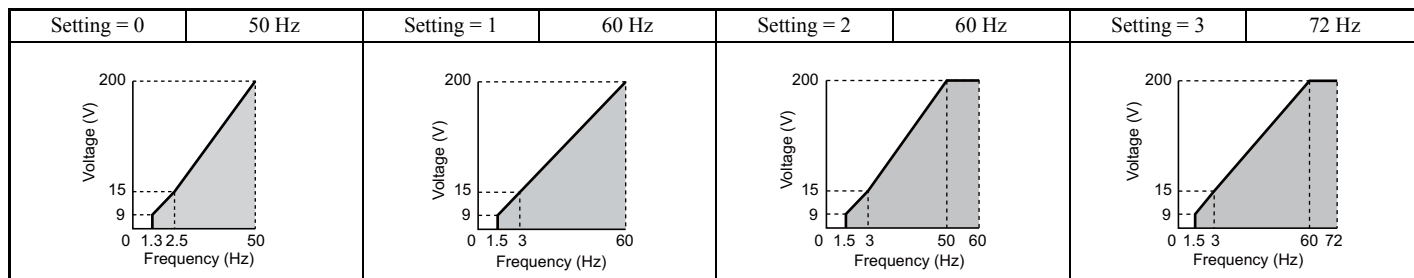
<1> V/f pattern F allows setting up a custom V/f pattern by changing parameters E1-04 to E1-13. When the drive is shipped, the default values for parameters E1-04 to E1-13 will be equal to V/f pattern 1 of the predefined patterns.

The following tables show details on predefined V/f patterns.

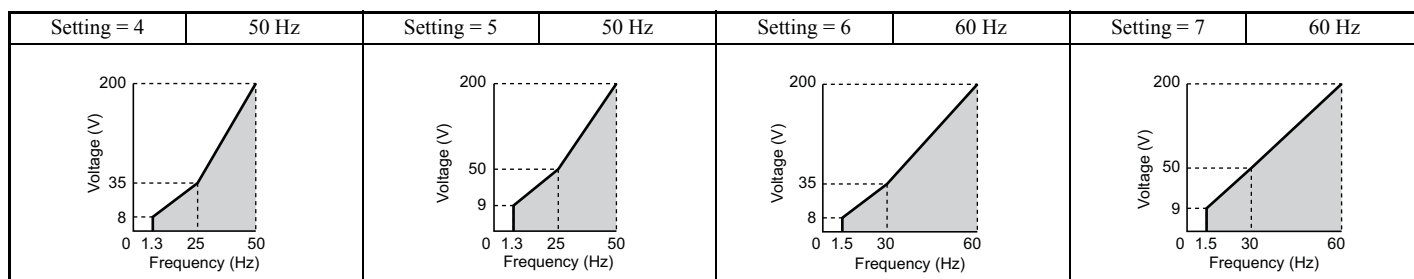
The following graphs are for 200 V class drives. Double the values when using a 400 V class drive.

**Predefined V/f Patterns for models CIMR-E□2A0004 to 2A0021 and CIMR-E□4A0002 to 4A0011**

**Table 5.16 Constant Torque Characteristics, Settings 0 to 3**

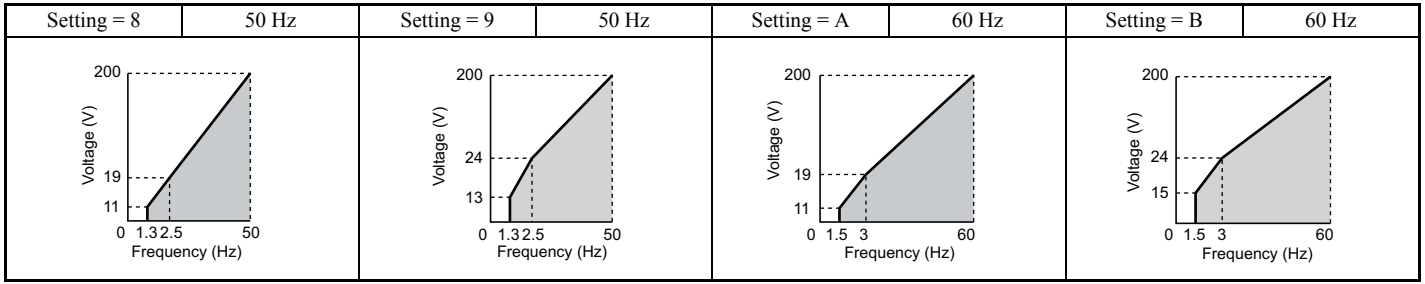


**Table 5.17 Derated Torque Characteristics, Settings 4 to 7**

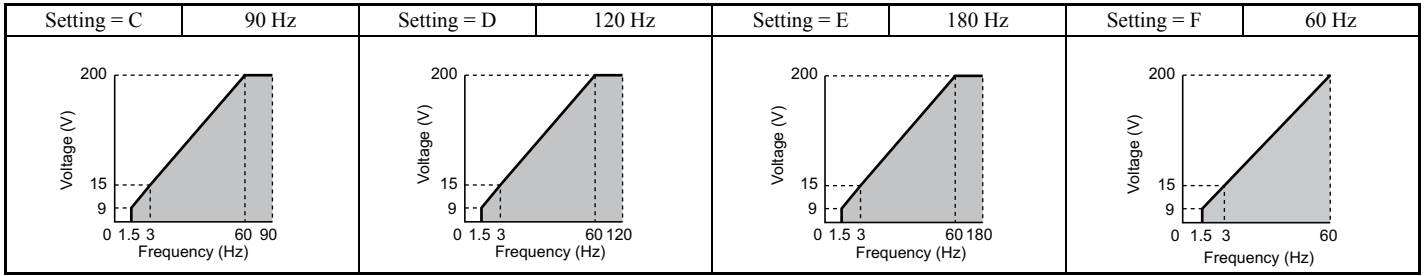


## 5.5 E: Motor Parameters

**Table 5.18 High Starting Torque, Settings 8 to B**



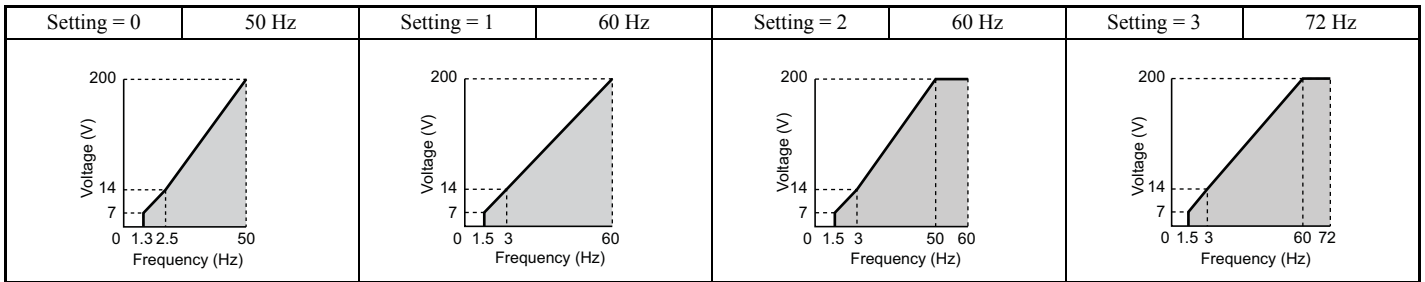
**Table 5.19 Rated Output Operation, Settings C to F**



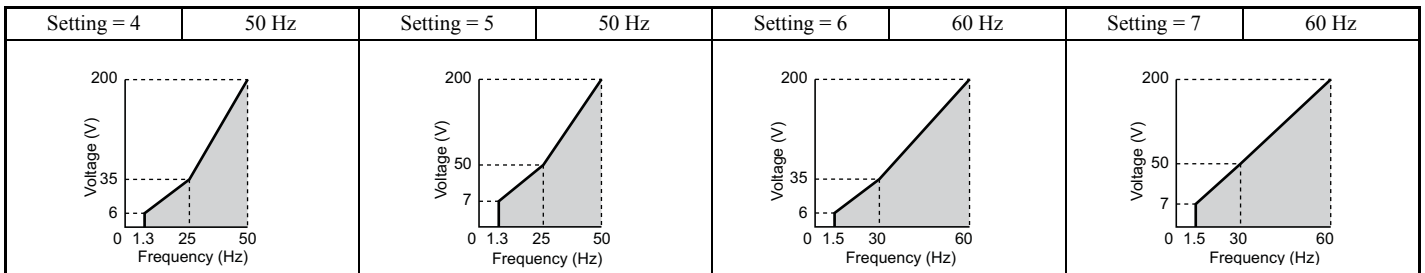
### Predefined V/f Patterns for Models CIMR-E□2A0030 to 2A0211 and CIMR-E□4A0018 to 4A0103

The following graphs are for 200 V class drives. Double values when using a 400 V class drive.

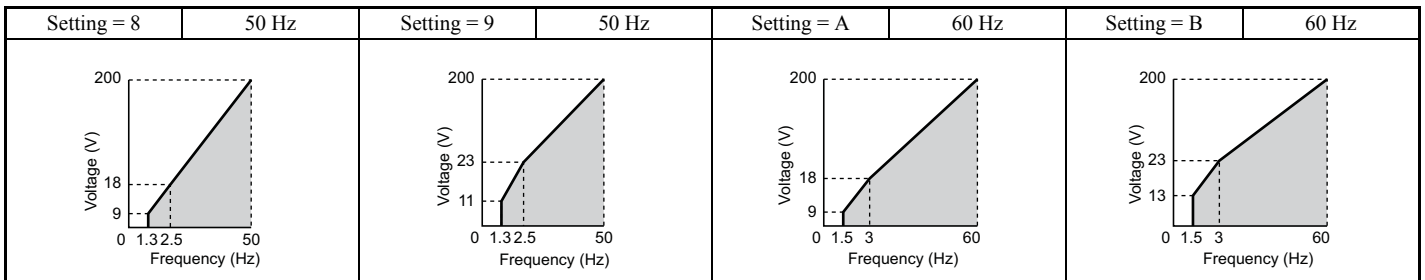
**Table 5.20 Rated Torque Characteristics, Settings 0 to 3**



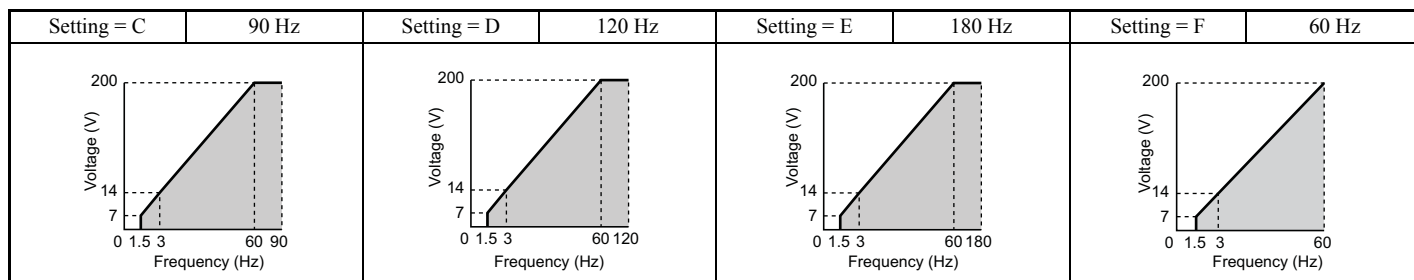
**Table 5.21 Derated Torque Characteristics, Settings 4 to 7**



**Table 5.22 High Starting Torque, Settings 8 to B**



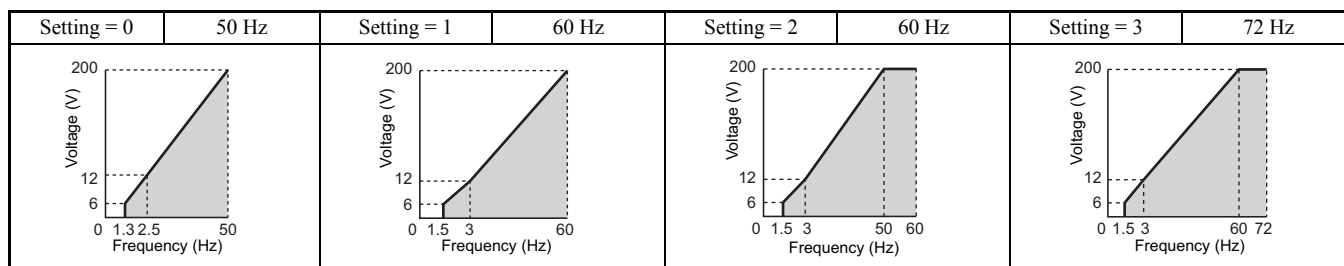
**Table 5.23 Constant Output, Settings C to F**



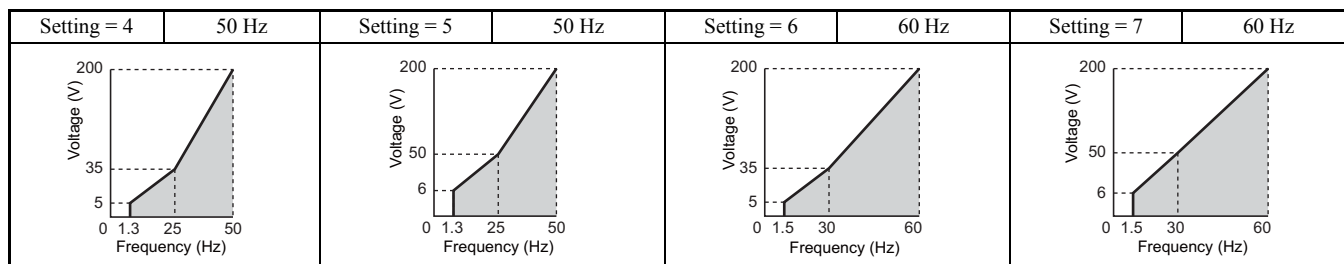
**Predefined V/f Patterns for Models CIMR-E□2A0250 to 2A0415 and CIMR-E□4A0139 to 4A1200**

The following graphs are for 200 V class drives. Double values when using a 400 V class drive.

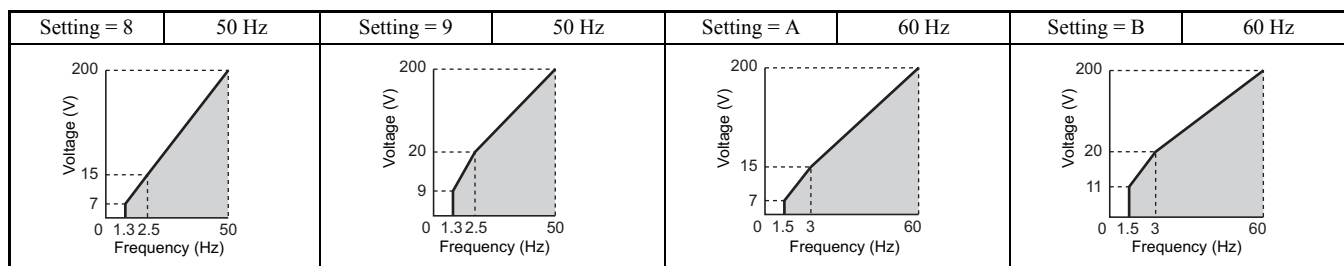
**Table 5.24 Rated Torque Characteristics, Settings 0 to 3**



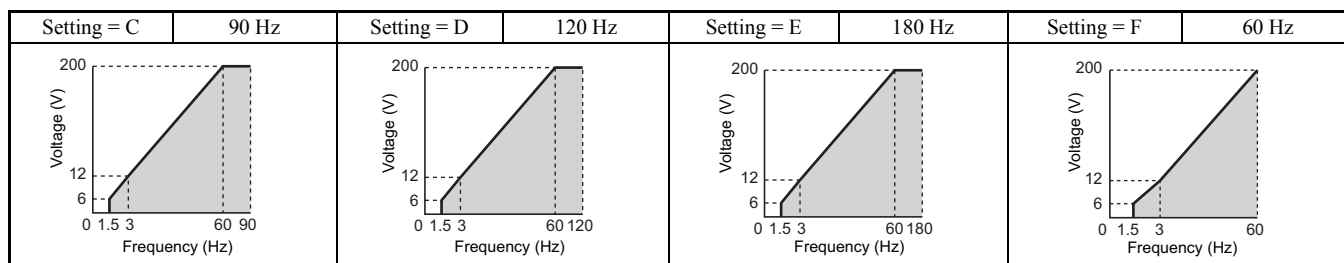
**Table 5.25 Derated Torque Characteristics, Settings 4 to 7**



**Table 5.26 High Starting Torque, Settings 8 to B**



**Table 5.27 Constant Output, Settings C to F**



**Setting a Custom V/f Pattern (Setting F: Default)**

Setting parameter E1-03 to F allows to set up a custom V/f pattern by changing parameters E1-04 to E1-13.

When initialized, the default values for parameters E1-04 to E1-13 will be equal to V/f pattern 1 of the predefined patterns.

## 5.5 E: Motor Parameters

### ■ E1-04 to E1-13: V/f Pattern Settings

If E1-03 is set to a preset V/f pattern (i.e., set to any value besides F), then the user can refer to parameters E1-04 through E1-13 to monitor the V/f pattern. To create a new V/f pattern, set E1-03 to F. Refer to [Figure 5.29](#) for an example custom V/f pattern.

**Note:** Certain E1-□□ parameters might not be visible depending on the selected control mode. [Refer to Parameter Table on page 360](#) for details.

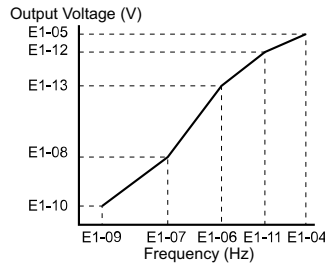
No.	Parameter Name	Setting Range	Default
E1-04	Maximum Output Frequency	40.0 to 200.0 Hz	<1> <2>
E1-05	Maximum Voltage	0.0 to 255.0 V <3>	<1> <2>
E1-06	Base Frequency	0.0 to [E1-04]	<1> <2>
E1-07	Middle Output Frequency	0.0 to [E1-04]	<1>
E1-08	Middle Output Frequency Voltage	0.0 to 255.0 V <3>	<1> <2>
E1-09	Minimum Output Frequency	0.0 to [E1-04]	<1> <2>
E1-10	Minimum Output Frequency Voltage	0.0 to 255.0 V <3>	<1> <2>
E1-11	Middle Output Frequency 2	0.0 to [E1-04]	0.0 Hz <4>
E1-12	Middle Output Frequency Voltage 2	0.0 to 255.0 V <3>	0.0 V <3> <4>
E1-13	Base Voltage	0.0 to 255.0 V <3>	0.0 V <3>

<1> Default setting is determined by the control mode.

<2> When using PM motors, the default setting is determined by the motor code set to E5-01.

<3> Values shown here are for 200 V class drives. Double values when using a 400 V class unit.

<4> Parameter ignored when E1-11 and E1-12 are set to 0.0.



**Figure 5.29 V/f Pattern**

- Note:**
1. The following condition must be true when setting up the V/f pattern:  $E1-09 \leq E1-07 < E1-06 \leq E1-11 \leq E1-04$
  2. To make the V/f pattern a straight line below E1-06, set  $E1-09 = E1-07$ . In this case the E1-08 setting is disregarded.
  3. E1-03 is unaffected when the parameters are initialized using parameter A1-03, but the settings for E1-04 through E1-13 are returned to their default values.
  4. Parameters E1-11, E1-12, and E1-13 should only be used to fine-tune the V/f pattern in the constant output range. These parameters rarely need to be changed.

## ◆ E2: Motor Parameters

These parameters contain the motor data. They are set automatically when Auto-Tuning is performed (this includes Rotational Auto-Tuning, Stationary Auto-Tuning 1 and 2). If Auto-Tuning cannot be performed, then manually enter the motor data directly to these parameters.

**Note:** As the motor parameters for a PM motor are set up in the E5-□□ parameters, parameters for induction motors (E2-□□) are hidden when a PM motor control mode is selected for motor 1 (when A1-02 is set to 5).

### ■ E2-01: Motor Rated Current

Provides motor control, protects the motor, and calculates torque limits. Set E2-01 to the full load amps (FLA) stamped on the motor nameplate. If Auto-Tuning completes successfully, the value entered to T1-04 will automatically be saved to E2-01.

No.	Parameter Name	Setting Range	Default
E2-01	Motor Rated Current	10% to 200% of the drive rated current.	Determined by o2-04

- Note:**
1. This value's number of decimal places depends on the drive model. The value will have two decimal places (0.01 A) if the drive is set for a Maximum Applicable Motor Capacity up to 11 kW (refer to [Table A.1](#) and [Table A.2](#)) and one decimal place (0.1 A) if the set Maximum Applicable Motor Capacity is higher than 11 kW.
  2. If the motor rated current in E2-01 is set lower than the motor no-load current in E2-03, than a parameter setting error will occur (oPE02). E2-03 must be set correctly to prevent this error.

### ■ E2-02: Motor Rated Slip

Sets the motor rated slip in Hz. The setting in E2-02 is used for motor protection and to calculate torque limits.

No.	Parameter Name	Setting Range	Default
E2-02	Motor Rated Slip	0.00 to 20.00 Hz	Determined by o2-04

Calculate the motor rated slip using the information written on the motor nameplate and the formula below:

$$E2-02 = f - (n \times p)/120$$

(f: rated frequency (Hz), n: rated motor speed (r/min), p: number of motor poles)

### ■ E2-03: Motor No-Load Current

Set the no-load current for the motor in amperes when operating at the rated frequency and the no-load voltage. The motor no-load current listed in the motor test report can be entered to E2-03 manually. Contact the motor manufacturer to receive a copy of the motor test report.

No.	Parameter Name	Setting Range	Default
E2-03	Motor No-Load Current	0 to [E2-01] (unit: 0.01 A)	Determined by o2-04

**Note:** This value's number of decimal places depends on the drive model. The value will have two decimal places (0.01 A) if the drive is set for a Maximum Applicable Motor Capacity up to 11 kW (refer to [Table A.1](#) and [Table A.2](#)) and one decimal place (0.1 A) if the set Maximum Applicable Motor Capacity is higher than 11 kW

### ■ E2-04: Number of Motor Poles

Set the number of motor poles to E2-04. If Auto-Tuning completes successfully, the value entered to T1-06 will automatically be saved to E2-04.

No.	Parameter Name	Setting Range	Default
E2-04	Number of Motor Poles	2 to 48	4

### ■ E2-05: Motor Line-to-Line Resistance

Sets the line-to-line resistance of the motor stator winding. If Auto-Tuning completes successfully, this value is automatically calculated. Remember that this value must be entered as line-to-line and not for each motor phase.

If Auto-Tuning is not possible, then contact the motor manufacturer to find out the line-to-line resistance or measure it manually. When using the manufacturer motor test report, calculate E2-05 by the formulas below.

- E-type insulation: Multiply 0.92 times the resistance value ( $\Omega$ ) listed on the test report at 75°C
- B-type insulation: Multiply 0.92 times the resistance value ( $\Omega$ ) listed on the test report at 75°C.
- F-type insulation: Multiply 0.87 times the resistance value ( $\Omega$ ) listed on the test report at 115°C.

No.	Parameter Name	Setting Range	Default
E2-05	Motor Line-to-Line Resistance	0.000 to 65.000 $\Omega$ </>	Determined by o2-04

</> The units are expressed in m $\Omega$  for models CIMR-E□4A0930 and 4A1200.

### ■ E2-10: Motor Iron Loss for Torque Compensation

This parameter sets the motor iron loss in watts.

No.	Parameter Name	Setting Range	Default
E2-10	Motor Iron Loss for Torque Compensation	0 to 65535 W	Determined by o2-04

## 5.5 E: Motor Parameters

### ■ E2-11: Motor Rated Power

This parameter sets the motor rated power in kW. If Auto-Tuning completes successfully, the value entered to T1-02 will automatically be saved to E2-11.

No.	Parameter Name	Setting Range	Default
E2-11	Motor Rated Power	0.00 to 650.00 kW </>	Determined by o2-04

<1> The display resolution depends on the motor rated power. Drive models 2A0004 to 2A0415 and 4A0002 to 4A0515 will display this value in units of 0.01 kW (two decimal places). Models 4A0675 to 4A1200 will display this value in units of 0.1 kW (one decimal place). [Refer to Model Number and Nameplate Check on page 29](#) for details.

### ■ Setting Motor Parameters Manually

Follow the instructions below when setting motor-related parameters manually instead of using the Auto-Tuning feature. Refer to the motor test report included with the motor to make sure the correct data is entered into the drive.

#### Setting the Motor Rated Current

Enter the motor rated current listed on the nameplate of the motor to E2-01.

#### Setting the Motor Rated Slip

Use the base speed listed on the motor nameplate to calculate the rated slip. Refer to the formula below, then enter that value to E2-02.

$$\text{Motor rated slip} = \text{rated frequency [Hz]} - \text{base speed [r/min]} \times (\text{no. of motor poles}) / 120$$

#### Setting the No-Load Current

Enter the no-load current at rated frequency and rated voltage to E2-03. The no-load current is not usually listed on the nameplate. Contact the motor manufacturer if the data cannot be found.

The default setting of the no-load current is for performance with a 4-pole Yaskawa motor.

#### Setting the Line-to-Line Resistance

E2-05 is normally set during Auto-Tuning. If Auto-Tuning cannot be performed, contact the manufacturer of the motor to find out what the correct resistance is between motor lines. The motor test report can also be used to calculate this value:

- E-type insulation: Multiply 0.92 times the resistance value ( $\Omega$ ) listed on the test report at 75°C.
- B-type insulation: Multiply 0.92 times the resistance value ( $\Omega$ ) listed on the test report at 75°C.
- F-type insulation: Multiply 0.87 times the resistance value ( $\Omega$ ) listed on the test report at 115°C.

#### Setting the Motor Leakage Inductance

The motor leakage inductance set to E2-06 determines the amount of voltage drop relative to the motor rated voltage. This value should be entered particularly for motors with a low degree of inductance, such as high-speed motors. As this information is not listed on the motor nameplate, contact the motor manufacturer to find out the correct value for the motor leakage inductance.

#### Setting the Motor Iron Loss for Torque Compensation

This value only needs to be set when using V/f Control. Enter this value in watts to E2-10. The drive uses this setting to improve the precision of torque compensation.

## ◆ E5: PM Motor Settings

These parameters set the motor data of a PM motor.

When Yaskawa motors are used, entering the motor code written on the motor nameplate will set up the E5-□□ parameters.

For all other PM motors, Auto-Tuning can be performed. If motor data is known, it can also be entered manually.

- Note:**
1. E5-□□ parameters are visible only when a PM motor control mode is selected (A1-02 = 5).
  2. E5-□□ parameters are not reset when the drive is initialized using parameter A1-03.



### ■ E5-01: Motor Code Selection

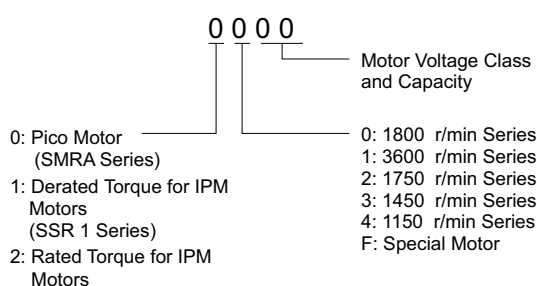
When Yaskawa motors are used, set the motor code for the PM motor being used. Depending on the motor code entered, the drive automatically sets several parameters to appropriate values. *Refer to Parameters that Change with the Motor Code Selection on page 404* for details on the supported motor codes and their parameter settings.

Setting parameter E5-01 to FFFF will allow to set the motor data manually using the E5-□□ parameters.

No.	Parameter Name	Setting Range	Default
E5-01	Motor Code Selection	0000 to FFFF	Determined by o2-04

- Note:**
1. E5-□□ parameters are not reset when the drive is initialized using parameter A1-03.
  2. When E5-01 is set to a value other than FFFF, the drive will not initialize using parameter A1-03.
  3. Changing E5-01 to FFFF from value other than FFFF will not change the values of parameters E5-02 through E5-24.
  4. Set E5-01 to FFFF when using a motor other than a Yaskawa SMRA, SSR1, or SST4 series.
  5. Default setting is:  
OLV/PM: Yaskawa SSR1 Series (1750 r/min)

*Figure 5.30* explains the motor code setting.



**Figure 5.30 PM Motor Code**

### ■ E5-02: Motor Rated Power

Sets the rated power of the motor. Determined by the value set to T2-04 during Stationary Auto-Tuning for PM motors or by entering the motor code to E5-01.

No.	Parameter Name	Setting Range	Default
E5-02	Motor Rated Power	0.10 to 650.00 kW <I>	Determined by E5-01

<I> The display resolution depends on the motor rated power. Drive models 2A0004 to 2A0415 and 4A0002 to 4A0515 will display this value in units of 0.01 kW (two decimal places). Models 4A0675 to 4A1200 will display this value in units of 0.1 kW (one decimal place). *Refer to Model Number and Nameplate Check on page 29* for details.

### ■ E5-03: Motor Rated Current

Sets the motor rated current in amps. This parameter is automatically set when the value is entered to T2-06 during the Auto-Tuning process.

No.	Parameter Name	Setting Range	Default
E5-03	Motor Rated Current	10 to 200% of drive rated current	Determined by E5-01

- Note:** This value's number of decimal places depends on the drive model. The value will have two decimal places (0.01 A) if the drive is set for a Maximum Applicable Motor Capacity up to 11 kW (refer to *Table A.1* and *Table A.2*) and one decimal place (0.1 A) if the set Maximum Applicable Motor Capacity is higher than 11 kW.

### ■ E5-04: Number of Motor Poles

Sets the number of motor poles. This parameter is automatically set when the value is entered to T2-08 during the Auto-Tuning process.

No.	Parameter Name	Setting Range	Default
E5-04	Number of Motor Poles	2 to 48	Determined by E5-01

## 5.5 E: Motor Parameters

### ■ E5-05: Motor Stator Resistance (r1)

Set the resistance for one motor phase. When measuring the resistance manually, make sure not to enter the line-to-line resistance into E5-05.

No.	Parameter Name	Setting Range	Default
E5-05	Motor Stator Resistance	0.000 to 65.000 Ω	Determined by E5-01

### ■ E5-06: Motor d-Axis Inductance (Ld)

Sets the d-axis inductance in 0.01 mH units. This parameter is set during the Auto-Tuning process.

No.	Parameter Name	Setting Range	Default
E5-06	Motor d-Axis Inductance	0.00 to 300.00 mH	Determined by E5-01

### ■ E5-07: Motor q-Axis Inductance (Lq)

Sets the q-axis inductance in 0.01 mH units. This parameter is set during the Auto-Tuning process.

No.	Parameter Name	Setting Range	Default
E5-07	Motor q-Axis Inductance	0.00 to 600.00 mH	Determined by E5-01

### ■ E5-09: Motor Induction Voltage Constant 1 (Ke)

Set the induced peak voltage per phase in units of 0.1 mV/(rad/s) [electrical angle]. Set this parameter when using an IPM motor with derated torque (SSR1 series or equivalent) or an IPM motor with constant torque (SST4 series or equivalent).

Set the voltage constant with E5-09 or E5-24 when E5-01 is set to FFFF. This parameter is set during Auto-Tuning for Yaskawa SSR1 or SST4 series PM motors.

No.	Parameter Name	Setting Range	Default
E5-09	Motor Induction Voltage Constant 1	0.0 to 2000.0 mV/(rad/s)	Determined by E5-01

**Note:** Ensure that E5-24 = 0 when setting parameter E5-09. An alarm will be triggered, however, if both E5-09 and E5-24 are set 0, or if neither parameter is set to 0. When E5-01 = FFFF, then E5-09 = 0.0.

### ■ E5-24: Motor Induction Voltage Constant 2 (Ke)

Set the induced phase-to-phase rms voltage in units of 0.1 mV/(r/min) [mechanical angle]. Set this parameter when using an SPM Motor (SMRA Series or equivalent).

When E5-01 is set to FFFF, use either E5-09 or E5-24 for setting the voltage constant. This parameter is set during Parameter Auto-Tuning for PM motors.

No.	Parameter Name	Setting Range	Default
E5-24	Motor Induction Voltage Constant 2	0.0 to 6500.0 mV/(r/min)	Determined by E5-01

**Note:** Ensure that E5-09 = 0 when setting parameter E5-24. An alarm will be triggered, however, if both E5-09 and E5-24 are set 0, or if neither parameter is set to 0. When E5-01 = FFFF, then E5-09 = 0.0.

### ■ E5-25: Polarity Judge Selection

Sets the polarity level (SD) that determines the motor poles at start.

No.	Parameter Name	Setting Range	Default
E5-25	Polarity Judge Selection	0 or 1	0

**Setting 0: Positive Polarity**

**Setting 1: Negative Polarity**

## 5.6 F: Option Settings

### ◆ F6: Communication Option Card

These parameters are to configure communication option cards and communication fault detection methods.

Some parameters apply to all communication option cards, while some parameters are used only for certain network options.

Parameter	Communication Protocol				
	CC-Link <1>	MECHATROLINK-II <1>	PROFIBUS-DP <1>	CANopen <1>	DeviceNet <1>
F6-01 to F6-03 to F6-08	○	○	○	○	○
F6-04, -10, -11, -14	○	–	–	–	–
F6-20 to F6-26	–	○	–	–	–
F6-30 to F6-32	–	–	○	–	–
F6-35 to F6-36	–	–	–	○	–
F6-50 to F6-63	–	–	–	–	○

<1> Under development

#### ■ F6-01: Communications Error Operation Selection

Determines drive operation if a communication error occurs.

No.	Parameter Name	Setting Range	Default
F6-01	Communications Error Operation Selection	0 to 3	1

**Setting 0: Ramp to stop (uses the deceleration time set to C1-02)**

**Setting 1: Coast to stop**

**Setting 2: Fast Stop (uses the Fast Stop time set to C1-09)**

**Setting 3: Alarm only (continue operation)**

#### ■ F6-02: External Fault from Comm. Option Detection Selection

Determines the detection method of an external fault initiated by a communication option (EF0).

No.	Parameter Name	Setting Range	Default
F6-02	External Fault from Comm. Option Detection Selection	0 or 1	0

**Setting 0: Always detected**

**Setting 1: Detection during run only**

#### ■ F6-03: External Fault from Comm. Option Operation Selection

Determines the operation when an external fault is initiated by a communication option (EF0).

No.	Parameter Name	Setting Range	Default
F6-03	External Fault from Comm. Option Operation Selection	0 to 3	1

**Setting 0: Ramp to stop**

**Setting 1: Coast to stop**

**Setting 2: Fast Stop**

**Setting 3: Alarm only (continue operation)**

#### ■ F6-07: Multi-Step Speed Enable/Disable when NetRef/ComRef is Selected

Selects how multi-step speed inputs are treated when the NetRef command is set.

No.	Parameter Name	Setting Range	Default
F6-07	NetRef/ComRef Function Selection	0, 1	0

**Setting 0: Multi-step speed operation disabled**

If the NetRef command is selected, multi-step speed input frequency references are disabled (like Yaskawa E7 drives).

## 5.6 F: Option Settings

---

### Setting 1: Multi-step speed operation enabled

Even if the NetRef command is selected, multi-step speed inputs are still active and can override the frequency reference from the communications option (like Yaskawa V7 drives).

#### ■ F6-08: Reset Communication Parameters

Determines whether communication-related parameters (F6-□□) are reset when the drive is initialized using parameter A1-03.

No.	Parameter Name	Setting Range	Default
F6-08	Reset Communication Parameters	0, 1	0

**Setting 0: Do not reset parameters F6-□□ when the drive is initialized with A1-03**

**Setting 1: Reset F6-□□ when the drive is initialized with A1-03**

**Note:** F6-08 is not reset when the drive is initialized, but does determine whether initializing the drive with A1-03 resets the other communication parameters, F6-□□.

---

### ◆ CC-Link Parameters

Parameters F6-04, F6-10, F6-11, and F6-14 set up the drive to operate on a CC-Link network.

For details on parameter settings, refer to the YASKAWA AC Drive 1000-Series Option CC-Link Installation Manual and Technical Manual.

---

### ◆ MECHATROLINK Parameters

Parameters F6-20 through F6-26 set up the drive to operate on a MECHATROLINK network.

For details on parameter settings, refer to the YASKAWA AC Drive 1000-Series Option MECHATROLINK-II Installation Manual and Technical Manual.

---

### ◆ PROFIBUS-DP Parameters

Parameters F6-30 through F6-32 set up the drive to operate on a PROFIBUS-DP network.

For details on parameter settings, refer to the YASKAWA AC Drive 1000-Series Option PROFIBUS-DP Installation Manual and Technical Manual.

---

### ◆ CANopen Parameters

Parameters F6-35 and F6-36 set up the drive to operate on a CANopen network.

For details on parameter settings, refer to the YASKAWA AC Drive 1000-Series Option CANopen Installation Manual and Technical Manual.

---

### ◆ DeviceNet Parameters

Parameters F6-50 through F6-63 set up the drive to operate on a DeviceNet network.

For details on parameter settings, refer to the YASKAWA AC Drive 1000-Series Option DeviceNet Installation Manual and Technical Manual.

## 5.7 H: Terminal Functions

H parameters are used to assign functions to the external terminals.

### ◆ H1: Multi-Function Digital Inputs

#### ■ H1-01 to H1-08: Functions for Terminals S1 to S8

These parameters assign functions to the multi-function digital inputs. The various functions and their settings are listed below in [Table 5.28](#).

No.	Parameter Name	Setting Range	Default
H1-01	Multi-Function Digital Input Terminal S1 Function Selection	1 to 9F	40 (F) <I>: Forward Run Command (2-wire sequence)
H1-02	Multi-Function Digital Input Terminal S2 Function Selection	1 to 9F	41 (F) <I>: Reverse Run Command (2-wire sequence)
H1-03	Multi-Function Digital Input Terminal S3 Function Selection	0 to 9F	24: External Fault
H1-04	Multi-Function Digital Input Terminal S4 Function Selection	0 to 9F	14: Fault Reset
H1-05	Multi-Function Digital Input Terminal S5 Function Selection	0 to 9F	3 (0) <I>: Multi-Step Speed Reference 1
H1-06	Multi-Function Digital Input Terminal S6 Function Selection	0 to 9F	4 (3) <I>: Multi-Step Speed Reference 2
H1-07	Multi-Function Digital Input Terminal S7 Function Selection	0 to 9F	6 (4) <I>: Jog Reference Selection
H1-08	Multi-Function Digital Input Terminal S8 Function Selection	0 to 9F	8: External Baseblock Command

<I> Number appearing in parenthesis is the default value after performing a 3-Wire initialization.

**Table 5.28 Multi-Function Digital Input Terminal Settings**

Setting	Function	Page	Setting	Function	Page
0	3-wire Sequence	<a href="#">182</a>	35	PI Input Level Selection	<a href="#">187</a>
1	LOCAL/REMOTE Selection	<a href="#">182</a>	36	External Reference 1/2 Selection 2	<a href="#">187</a>
2	External Reference 1/2 Selection	<a href="#">183</a>	40	Forward Run Command (2-wire Sequence)	<a href="#">187</a>
3	Multi-step Speed Reference 1	<a href="#">183</a>	41	Reverse Run Command (2-wire Sequence)	
4	Multi-step Speed Reference 2		42	Run Command (2-wire Sequence 2)	<a href="#">188</a>
6	Jog Reference Selection	<a href="#">183</a>	43	FWD/REV Command (2-wire Sequence 2)	
7	Accel/Decel Time Selection 1	<a href="#">183</a>	44	Offset Frequency 1	<a href="#">188</a>
8	Baseblock Command (N.O.)	<a href="#">183</a>	45	Offset Frequency 2	
9	Baseblock Command (N.C.)		46	Offset Frequency 3	
A	Accel/Decel Ramp Hold	<a href="#">183</a>	47	Node Setup	<a href="#">188</a>
B	Drive Overheat Alarm (oH2)	<a href="#">183</a>	50	Motor Pre-Heat 2	<a href="#">188</a>
C	Analog Terminal Input Selection	<a href="#">184</a>	60	Motor Pre-Heat 1	<a href="#">188</a>
F	Through Mode	<a href="#">184</a>	61	External Speed Search Command 1	<a href="#">188</a>
10	Up Command	<a href="#">184</a>	62	External Speed Search Command 2	<a href="#">188</a>
11	Down Command		63	Field Weakening	<a href="#">189</a>
12	Forward Jog	<a href="#">185</a>	65	KEB Ride-Thru 1 (N.C.)	<a href="#">189</a>
13	Reverse Jog		66	KEB Ride-Thru 1 (N.O.)	
14	Fault Reset	<a href="#">185</a>	67	Communications Test Mode	<a href="#">189</a>
15	Fast Stop (N.O.)	<a href="#">185</a>	68	High Slip Braking	<a href="#">189</a>
17	Fast Stop (N.C.)	<a href="#">185</a>	69	Jog 2	<a href="#">189</a>
18	Timer Function Input	<a href="#">186</a>	6A	Drive Enable	<a href="#">189</a>
19	PI Disable	<a href="#">186</a>	7A	Keb Ride-Thru 2 (N.C.)	<a href="#">189</a>
1B	Program Lockout	<a href="#">186</a>	7B	Keb Ride-Thru 2 (N.O.)	
1E	Reference Sample Hold	<a href="#">186</a>	7C	Short Circuit Braking (N.O.)	<a href="#">189</a>
20 to 2F	External Fault	<a href="#">186</a>	7D	Short Circuit Braking (N.C.)	
30	PI Integral Reset	<a href="#">187</a>	90 to 97	DriveWorksEZ Digital Input 1 to 8	<a href="#">190</a>
31	PI Integral Hold	<a href="#">187</a>	9F	DriveWorksEZ Disable	<a href="#">190</a>
34	PI Soft Starter Cancel	<a href="#">187</a>	–	–	–

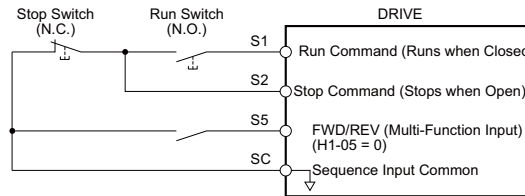
## 5.7 H: Terminal Functions

### Setting 0: 3-Wire Sequence

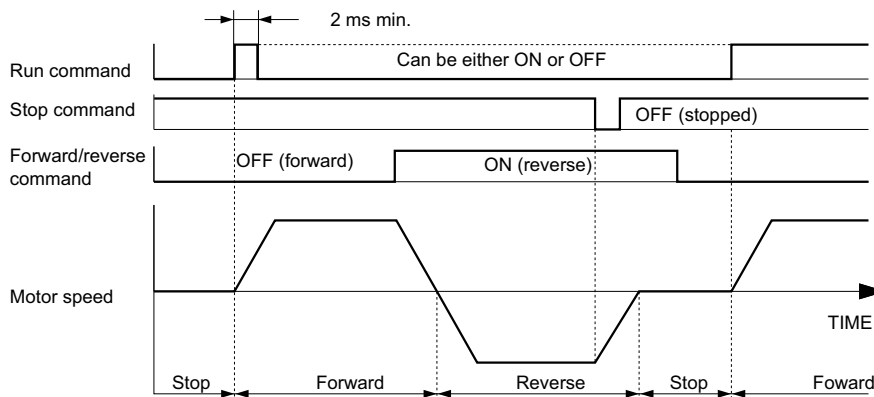
When one of the digital inputs is programmed for 3-wire control, that input becomes a forward/reverse directional input, S1 becomes the Run command input, and S2 becomes the Stop command input.

The drive will start the motor when the input S1 set for the Run command is closed for longer than 2 ms. The drive will stop the operation when the Stop input S2 is released for a brief moment. Whenever the input programmed for 3 wire sequence is open, the drive will be set for forward direction. If the input is closed, the drive is set for reverse direction.

**Note:** When 3-wire sequence is selected, the Run and Stop commands must be input via S1 and S2.



**Figure 5.31 3-Wire Sequence Wiring Diagram**



**Figure 5.32 3-Wire Sequence**

- Note:**
1. The Run command must be closed for more than 2 ms.
  2. If the Run command is active at power up and b1-17 = 0 (Run command at power up not accepted), the Run LED will flash to indicate that protective functions are operating. If required by the application, set b1-17 to 1 to have the Run command issued automatically as soon as the drive is powered up.

**WARNING! Sudden Movement Hazard.** Ensure start/stop and Hardwire Baseblock circuits are wired properly and in the correct state before energizing the drive. Failure to comply could result in death or serious injury from moving equipment.

**WARNING!** The drive may start unexpectedly in reverse direction after power up if it is wired for 3-wire sequence but set up for 2-wire sequence (default). Make sure b1-17 is set to "0" (drive does not accept a Run command active at power up). When initializing the drive use 3-wire initialization. Failure to comply could result in death or serious injury from moving equipment.

### Setting 1: LOCAL/REMOTE Selection

This setting allows the input terminal to determine if the drive will run in LOCAL mode or REMOTE mode.

Status	Description
Closed	LOCAL: Frequency reference and Run command are input from the digital operator.
Open	REMOTE: Frequency reference and Run command are input from the external reference that has been selected. If a digital input set to H1-□□ = 2 is active, they will be read from external reference source 2 (b1-15 and b1-16). Otherwise they will be read from external reference source 1 (b1-01 and b1-02).

- Note:**
1. If one of the multi-function input terminals is set to for LOCAL/REMOTE, then the LO/RE key on the operator will be disabled.
  2. When the drive is set to LOCAL, the LO/RE LED will light.
  3. The default setting of the drive is not to allow switching between LOCAL and REMOTE during run. To allow the drive to switch between LOCAL and REMOTE during run, [Refer to b1-07: LOCAL/REMOTE Run Selection on page 135.](#)

### Setting 2: External Reference 1/2 Selection

This function can be used to switch the Run command and frequency reference source between External reference 1 and 2 if the drive is in the REMOTE mode.

Status	Description
Open	External reference 1 is used (defined by parameters b1-01 and b1-02)
Closed	External reference 2 is used (defined by parameters b1-15 and b1-16)

**Note:** With default settings the drive is not to allow switching between External reference 1 and 2 during run. *Refer to b1-07: LOCAL/REMOTE Run Selection on page 135* if this feature is required by the application.

### Setting 3 and 4: Multi-Step Speed Reference 1/2

Used to switch multi-step speed frequency references d1-01 to d1-08 by digital inputs. Refer to *d1: Frequency Reference on page 165* for details.

### Setting 6: Jog Reference Selection

The Jog frequency set in parameter d1-17 becomes the frequency reference when the input terminal closes. Refer to *d1: Frequency Reference on page 165* for details.

### Setting 7: Accel/Decel Time Selection 1

Used to switch between accel/decel times 1 (C1-01 and C1-02) and 2 (C1-03 and C1-04). *Refer to C1-01 to C1-04: Accel, Decel Time 1/2 on page 160* for details.

### Setting 8, 9: Baseblock Command (N.O., N.C.)

When the drive receives a Baseblock command, the output transistor stop switching and the motor coasts to stop. During this time, the alarm “bb” will flash on the digital operator to indicate baseblock. When baseblock ends and a Run command is active, the drive performs Speed Search to get the motor running again.

Digital Input Function	Drive Operation	
	Input Open	Input Closed
Setting 8 (N.C.)	Baseblock (Interrupt output)	Normal operation
Setting 9 (N.O.)	Normal operation	Baseblock (Interrupt output)

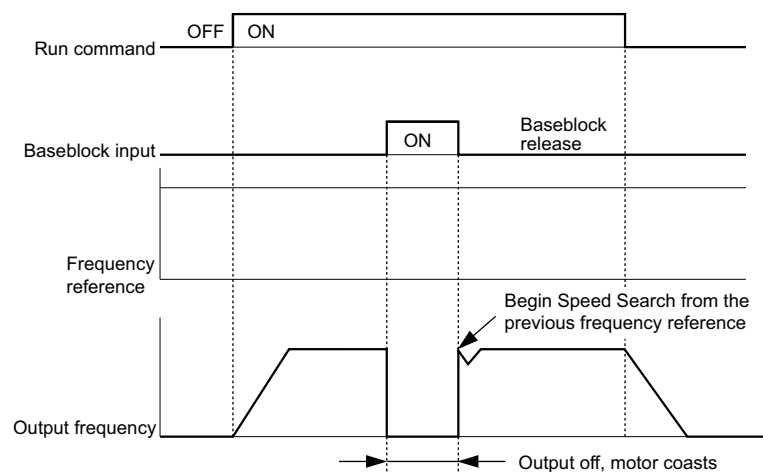


Figure 5.33 Baseblock Operation During Run

### Setting A: Accel/Decel Ramp Hold

When the digital input programmed for the Accel/decel ramp hold function closes, the drive will lock (“hold”) the output frequency. Acceleration or deceleration will resume once the input is opened again.

If the Accel/decel ramp hold function is enabled (d4-01 = 1), the drive will save the output frequency to memory whenever the Ramp Hold input is closed. When the drive is restarted after stop or after power supply interruption, the output frequency that was saved will become the frequency reference (provided that the Accel/decel ramp hold input is still closed). *Refer to d4-01: Frequency Reference Hold Function Selection on page 167* for details.

### Setting B: Drive Overheat Alarm (oH2)

Triggers an oH2 alarm when the contact closes. Because this is an alarm, drive operation is not affected.

## 5.7 H: Terminal Functions

### Setting C: Analog Terminal Input Selection (terminal A1, A2, A3)

When closed, the terminals specified in H3-14 are enabled. When open, the drive disregards the input signal to the analog terminals.

### Setting F: Through Mode

Select this setting when using the terminal in a pass-through mode. When set to F, an input does not trigger any function in the drive. Setting F, however, still allows the input status to be read out by a PLC via a communication option or MEMOBUS/Modbus communications.

### Setting 10, 11: Up, Down Command

Using the Up/Down function allows the frequency reference to be set by two push buttons. One digital input must be programmed as the Up input (H1-□□ = 10) to increase the frequency reference, and the other one must be programmed as the Down input (H1-□□ = 11) to decrease the frequency reference.

The Up/Down function has priority over the frequency references from the digital operator, the analog inputs, and the pulse input (b1-01 = 0, 1, 4). If the Up/Down function is used, then references provided by these sources will be disregarded.

The inputs operate as shown in the table below.

Status		Drive Operation
Up (10)	Down (11)	
Open	Open	Hold current frequency reference
Closed	Open	Increase frequency reference
Open	Closed	Decrease frequency reference
Closed	Closed	Hold current frequency reference

- Note:**
1. An oPE03 alarm will occur when only one of the functions Up/Down is programmed for a digital input.
  2. An oPE03 alarm will occur if the Up/Down function is assigned to the terminals while another input is programmed for the Accel/ decel ramp hold function. For more information on alarms, [Refer to Drive Alarms, Faults, and Errors on page 260](#).
  3. The Up/Down function can only be used for External reference 1. Consider this when using Up/Down and the external reference switching command (H1-□□ = 2).

### Using the Up/Down Function with Frequency Reference Hold (d4-01)

- When the frequency reference hold function is disabled (d4-01 = 0), the Up/Down frequency reference will be reset to 0 when the Run command is cleared or the power is cycled.
- When d4-01 = 1, the drive will save the frequency reference set by the Up/Down function. When the Run command or the power is cycled, the drive will restart with the reference value that was saved. The value that was saved can be reset by closing either the Up or Down input without having a Run command active. [Refer to d4-01: Frequency Reference Hold Function Selection on page 167](#).

### Using the Up/Down Function with Frequency Reference Limits

The upper frequency reference limit is determined by parameter d2-01.

The value for the lower frequency reference limit depends on the setting of parameter d4-10, and can be set by an analog input or parameter d2-02. [Refer to d4-10: Up/Down Frequency Reference Limit Selection on page 168](#) for details.

When a Run command is applied, the lower limits work as follows:

- If the lower limit is set by d2-02 only, the drive will accelerate to this limit as soon as a Run command is entered.
- If the lower limit is determined by an analog input only, the drive will accelerate to the limit as long as the Run command and an Up or Down command are active. It will not start running if only the Run command is on.
- If the lower limit is set by both an analog input and d2-02, and the analog limit is higher than the d2-02 value, then the drive will accelerate to the d2-02 value when a Run command is input. Once the d2-02 value is reached, it will continue acceleration to the analog limit only if an Up or Down command is set.

[Figure 5.34](#) shows an Up/Down function example with a lower frequency reference limit set by d2-02, and the frequency reference hold function both enabled and disabled.



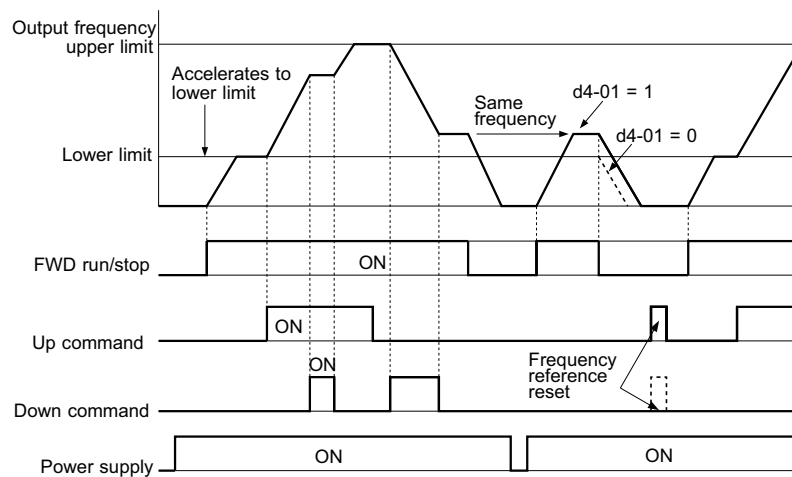


Figure 5.34 Up/Down Command Operation

### Setting 12, 13: Forward Jog, Reverse Jog

Digital inputs programmed as Forward Jog (H1-□□ = 12) and Reverse Jog (H1-□□ = 13) will be Jog inputs that do not require a Run command. Closing the terminal set for Forward Jog input will cause the drive to ramp to the Jog frequency reference (d1-17) in the forward direction. The Reverse Jog will cause the same action in the reverse direction. The Forward Jog and Reverse Jog command can be set independently.

**Note:** The Forward Jog and Reverse Jog commands override all other frequency references. However, if the drive is set to prohibit reverse rotation (b1-04 = 1), then activating Reverse Jog will have no effect. If both the Forward Jog and Reverse Jog are input simultaneously for 500 ms or more, an alarm will occur and the drive will ramp to stop.

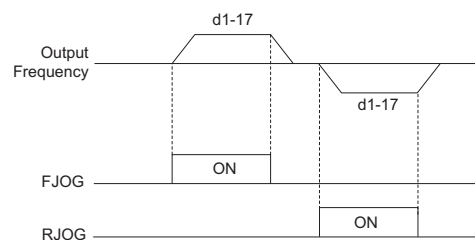


Figure 5.35 FJOG/RJOG Operation

### Setting 14: Fault Reset

Whenever the drive detects a fault condition, the fault output contact will close and the drive's output will shut off. The motor then coasts to stop (specific stopping methods can be selected for some faults such as L1-04 for motor overheating). Once the Run command is removed, the fault can be cleared by either the RESET key on the digital operator or by closing a digital input configured as a Fault Reset (H1-□□ = 14).

**Note:** Fault Reset commands are ignored as long as the Run command is present. To reset a fault, first remove the Run command.

### Setting 15, 17: Fast Stop (N.O., N.C.)

The Fast Stop function operates much like an emergency stop input to the drive. If a Fast Stop command is input while the drive is running, the drive will decelerate to a stop by the deceleration time set to C1-09 (*Refer to C1-09: Fast Stop Time on page 161*). The drive can only be restarted after it has come to a complete stop, the Fast Stop input is off, and the Run command has been switched off.

- To trigger the Fast Stop function with a N.O. switch, set H1-□□ = 15.
- To trigger the Fast Stop function with a N.C. switch, set H1-□□ = 17.

Figure 5.36 shows an operation example of Fast Stop.

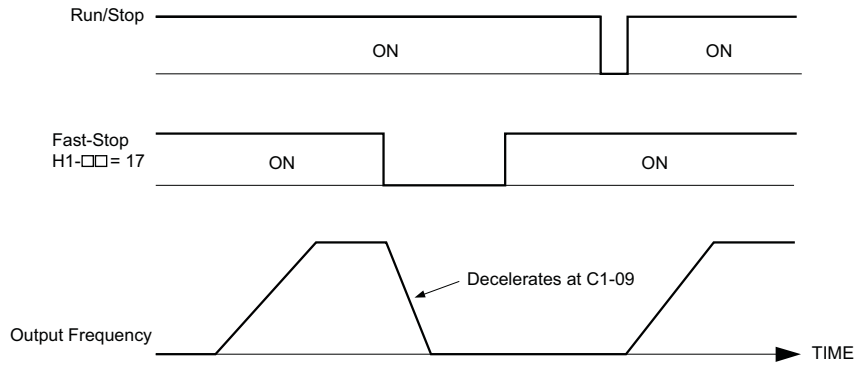


Figure 5.36 Fast Stop Sequence

**NOTICE:** Rapid deceleration can trigger an overvoltage fault. When faulted, the drive output shuts off, and the motor coasts. To avoid this uncontrolled motor state and to ensure that the motor stops quickly and safely, set an appropriate Fast Stop time to C1-09.

### Setting 18: Timer Function Input

This setting configures a digital input terminal as the input for the timer function. Use this setting combination with the timer function output (H2-□□ = 12). Refer to [b4: Delay Timers on page 144](#) for details.

### Setting 19: PI Disable

When the PI function has been enabled by parameter b5-01, it can be indefinitely disabled by closing a digital input. When the input is released, the drive resumes PI operation. Also refer to [PI Block Diagram on page 147](#).

### Setting 1B: Program Lockout

When an input is programmed for Program Lockout, parameters values cannot be changed as long as this input is open (it is still possible to view and monitor parameter settings).

### Setting 1E: Reference Sample Hold

This function allows the user to sample an analog frequency reference signal being input to terminal A1, A2, or A3 and hold the frequency reference at the sampled level. Once the Analog Frequency Reference Sample/Hold function is held for at least 100 ms, the drive reads the analog input and changes the frequency reference to the newly sampled speed as illustrated in [Figure 5.37](#).

When the power is shut off and the sampled analog frequency reference is cleared, the frequency reference is reset to 0.

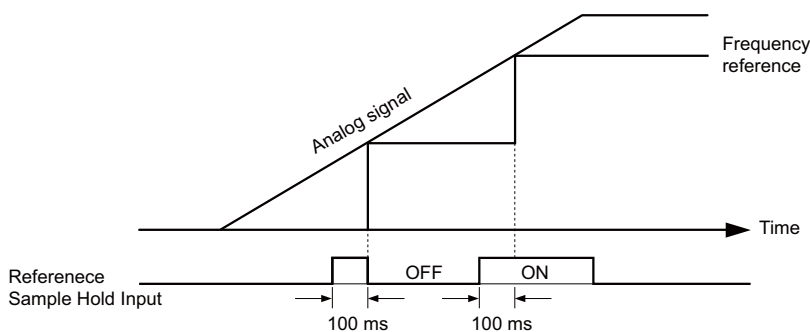


Figure 5.37 Analog Frequency Reference Sample/Hold

An oPE03 error will occur when one of the following functions is used simultaneously with the Analog frequency reference sample/hold command.

- Hold accel/decel stop (setting: A)
- Up command, Down command (setting: 10, 11)
- Offset frequency (setting: 44 to 46)
- Up or Down functions (setting: 75, 76)

### Setting 20 to 2F: External Fault

By using the External fault command, the drive can be stopped when problems occur with external devices.

To use the External fault command, set one of the multi-function digital inputs to any value between 20 to 2F. The digital operator will display EF□ where □ is the number of the terminal to which the external fault signal is assigned.

For example, if an external fault signal is input to terminal S3, “EF3” will be displayed.

Select the value to be set in H1-□□ from a combination of any of the following three conditions:

- Signal input level from peripheral devices (N.O., N.C.)
- External fault detection method
- Operation after external fault detection

The following table shows the relationship between the conditions and the value set to H1-□□:

Setting	Terminal Status <1>		Detection Conditions <2>		Stopping Method			
	N.O.	N.C.	Always Detected	Detected during Run only	Ramp to Stop (fault)	Coast to Stop (fault)	Fast Stop (fault)	Alarm Only (continue running)
20	0		0		0			
21		0	0		0			
22	0			0	0			
23		0		0	0			
24	0		0			0		
25		0	0			0		
26	0			0		0		
27		0		0		0		
28	0		0				0	
29		0	0				0	
2A	0			0			0	
2B		0		0			0	
2C	0		0					0
2D		0	0					0
2E	0			0				0
2F		0		0				0

<1> Determine the terminal status for each fault, i.e., whether the terminal is normally open or normally closed.

<2> Determine whether detection for each fault should be enabled only during run or always detected.

### Setting 30: PI Integral Reset

By configuring one of the digital inputs for PI integral reset (H1-□□ = 30), the value of the integral component in PI control will be reset to 0 whenever the terminal is closed. [Refer to PI Block Diagram on page 147](#) for more details.

### Setting 31: PI Integral Hold

By configuring a digital input for Integral Hold (H1-0□ = 31), the value of the integral component of the PI control is locked as long as the input is active. The PI controller resumes integral operation from the hold value as soon as the integral hold input is released. [Refer to PI Block Diagram on page 147](#) for more information on this function.

### Setting 34: PI Soft Starter Cancel

A digital input configured as a PI soft starter cancel input (H1-0□ = 34) can be used to enable or disable the PI soft starter and thereby canceling the PI accel/decel time (b5-17). [Refer to PI Block Diagram on page 147](#).

### Setting 35: PI Input Level Selection

Allows an input terminal to switch the sign of the PI input. [Refer to PI Block Diagram on page 147](#) for details.

### Setting 36: External Reference 1/2 Selection 2

This function can be used to switch the Run command and frequency reference source between External reference 1 and 2 if the drive is in the REMOTE mode.

Status	Description
CLOSED	Run command and frequency reference source 1 (determined by b1-01 and b1-02)
OPEN	Run command and frequency reference source 2 (determined by b1-15 and b1-16)

**Note:** With default settings the drive is not to allow switching between External reference 1 and 2 during run. Refer to [b1-07: LOCAL/REMOTE Run Selection on page 135](#) if this feature is required by the application.

### Setting 40, 41: Forward Run, Reverse Run Command for 2-wire Sequence

Configures the drive for a 2-wire sequence.

## 5.7 H: Terminal Functions

When an input terminal set to 40 closes, the drive operates in the forward direction. When an input set for 41 closes, the drive will operate in reverse. Closing both inputs at the same time will result in an external fault.

- Note:**
1. This function cannot be used simultaneously with settings 42 and 43.
  2. The same functions are assigned to terminals S1 and S2 when the drive is initialized for 2-wire sequence.

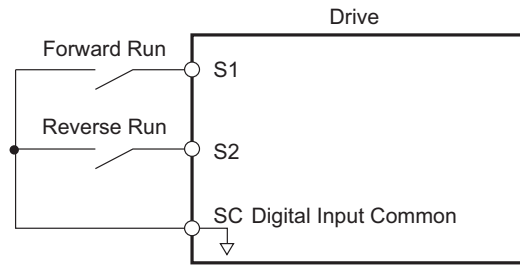


Figure 5.38 Example Wiring Diagram for 2-Wire Sequence

### Setting 42, 43: Run and Direction Command for 2-wire Sequence 2

Sets the drive for 2-wire sequence 2.

When an input terminal programmed for 42 is closed, the drive will operate in the direction selected. When the input opens, the drive will stop. The input programmed for 43 selects the direction. If it is open, forward direction is selected. If it is closed, reverse direction is selected.

**Note:** This function cannot be used simultaneously with settings 40 and 41.

### Setting 44, 45, 46: Offset Frequency 1, 2, 3

These inputs can be used to add offset frequencies d7-01, d7-02, and d7-03 to the frequency reference. [Refer to d7-01 to d7-03: Offset Frequency 1 to 3 on page 169](#) for details.

### Setting 47: Node Setup

If the SI-S3 option card is connected, closing this terminal will set a node address for operation on a CANopen network.

### Setting 50: Motor Pre-Heat 2

Sets the DC preheat current for multi-function input setting 50 as a percentage of motor rated current (E2-01). Refer to setting 60: Motor Pre-Heat 1 for detail.

### Setting 60: Motor Pre-Heat 1

In order to prevent condensation on the motor windings, a DC current can be circulated through the windings. The heat produced by the current in the windings will prevent the moisture from condensation on the wire. Motor Pre-Heating can only be initiated by closing a digital input programmed as a Motor Pre-Heat input (H1-0□ = 60). The level of the DC current used by the Motor Pre-Heat function is determined by b2-09.

A Run input will be given priority over a Motor Pre-Heat input. When the Run command is removed, if the Motor Pre-Heat input is still closed, the motor pre-heating will resume.

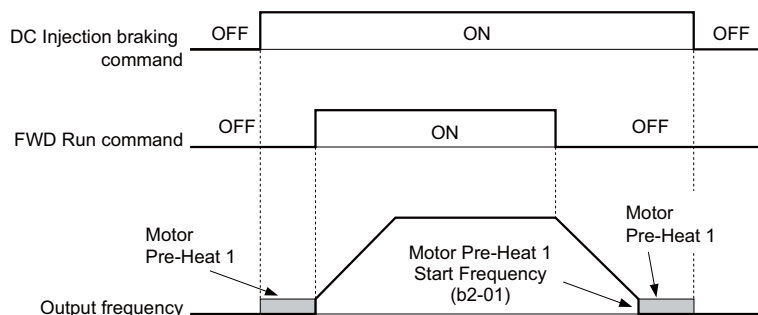


Figure 5.39 DC Injection Braking Input Timing Diagram

### Setting 61, 62: External Speed Search Command 1, 2

These input functions can be used to enable Speed Search even if parameter b3-01 = 0 (no Speed Search at start). [Refer to Activating of Speed Search on page 142](#) for details on how to use the input signals. [Refer to b3: Speed Search on page 139](#) for more about Speed Search.

**Note:** Operator error oPE03 will result if both Speed Search 1 and Speed Search 2 are set to the input terminals at the same time.

### Setting 63: Field Weakening

Enabled in V/f Control. When closed, Field Weakening is performed. For details, [Refer to d6: Field Weakening and Field Forcing on page 169](#).

### Setting 65, 66: KEB Ride-Thru 1 (N.C.), 2 (N.O.)

Used to enable the KEB Ride-Thru function selected in parameter L2-29. [Refer to KEB Ride-Thru Function on page 215](#) for more information on this function.

Digital Input Function	Drive Operation	
	Input Open	Input Closed
Setting 65 (N.C.)	KEB Ride-Thru Deceleration	Normal operation
Setting 66 (N.O.)	Normal operation	KEB Ride-Thru Deceleration

**Note:** Both KEB Ride-Thru 1 and 2 cannot be assigned to the input terminals at the same time. This will trigger setting error oPE03.

### Setting 67: Communication test mode

The drive has a built-in function for self-diagnosing serial communications operation. The test involves wiring the send and receive terminals of the RS-485/422 port together. The drive transmits data and then confirms that the communications are received normally. [Refer to Self-Diagnostics on page 436](#) for details on how to use this function.

### Setting 68: High Slip Braking

Closing an input programmed for this function triggers High Slip Braking (available only in V/f control mode). Once HSB is started, the drive has to come to a complete stop and the HSB command must be removed before a restart can be performed. [Refer to n3: High Slip Braking \(HSB\) and Overexcitation Braking on page 241](#).

### Setting 69: Jog 2

The Jog 2 function applies to 3-Wire control only. If a digital input is configured as Jog 2 (H1-□□ = 69) when the drive is not in 3-Wire Control, an oPE03 fault will occur. The Jog 2 input will cause the drive to ramp to the Jog Frequency Reference (d1-17) in the direction dictated by the Fwd/Rev input of the 3-Wire Control mode. Accelerating to and from the Jog Frequency Reference will be determined by the active Accel/Decel parameters.

### Setting 6A: Drive Enable

A digital input configured as a “Drive enable” (H1-□□ = 6A) will prevent the drive from executing a Run command until the input is closed. When the input is open, the digital operator will display ÅgdnEÅh to indicate that the drive is disabled.

If a Run command is enabled before the terminal set for “Drive enable” closes, then the drive will not run until the Run command is cycled (i.e., a new Run command is required). If the input is opened while the drive is running, the drive will stop according to the stop method set to b1-03 (Refer to b1-03: Stopping Method Selection on page 125).

### Setting 7A, 7B: KEB Ride-Thru 2 (N.C., N.O.)

An input terminal set to 7A or 7B can trigger Single Drive KEB Ride-Thru during deceleration. If enabled, L2-29 is disregarded. Refer to [KEB Ride-Thru Function on page 215](#) for details.

Digital Input Function	Drive Operation	
	Input Open	Input Closed
Setting 7A (N.C.)	Single Drive KEB Ride-Thru 2	Normal operation
Setting 7B (N.O.)	Normal operation	Single Drive KEB Ride-Thru 2

**Note:** KEB Ride-Thru 1 and 2 cannot both be assigned to the input terminals at the same time. Doing so will trigger an oPE3 error.

### Setting 7C, 7D: Short Circuit Braking (N.O., N.C.) (OLV/PM)

An input programmed for this function can be used to activate Short Circuit Braking in Open Loop Vector control modes for PM motors. By linking all three phases of a PM motor, Short Circuit Braking creates a braking torque that can be used to stop a rotating motor or prevent a motor from coasting due to external forces (such as the windmill effect in fan applications). Parameter b2-18 can be used to limit the current during Short Circuit Braking.

Digital Input Function	Drive Operation	
	Input Open	Input Closed
Setting 7C (N.O.)	Normal operation	Short Circuit Braking
Setting 7D (N.C.)	Short-Circuit Braking	Normal operation

## 5.7 H: Terminal Functions

### Setting 90 to 97: DriveWorksEZ Digital Input 1 to 8

These settings are for digital inputs functions used in DriveWorksEZ. Normally there is no need to change these settings.

### Setting 9F: DriveWorksEZ Disable

This function is used to enable or disable a DriveWorksEZ program in the drive. An input programmed for this function is effective only if A1-07 = 2.

Status	Description
Open	DriveWorksEZ enabled
Closed	DriveWorksEZ disabled

## ◆ H2: Multi-Function Digital Outputs

### ■ H2-01 to H2-03: Terminal M1-M2, M3-M4, and M5-M6 Function Selection

The drive has three multi-function output terminals. [Table 5.29](#) lists the functions available for these terminals using H2-01, H2-02, and H2-03.

No.	Parameter Name	Setting Range	Default
H2-01	Terminal M1-M2 Function Selection (relays)	0 to 192	0: During run
H2-02	Terminal M3-M4 Function Selection (relays)	0 to 192	1: Zero Speed
H2-03	Terminal M5-M6 Function Selection (relays)	0 to 192	2: Speed agree 1

**Table 5.29 Multi-Function Digital Output Terminal Settings**

Setting	Function	Page	Setting	Function	Page
0	During Run	<a href="#">190</a>	1E	Restart Enabled	<a href="#">196</a>
1	Zero Speed	<a href="#">191</a>	1F	Motor Overload Alarm (oL1)	<a href="#">196</a>
2	Speed Agree 1	<a href="#">191</a>	20	Drive Overheat Pre-alarm (oH)	<a href="#">196</a>
3	User-set Speed Agree 1	<a href="#">192</a>	2F	Maintenance Period	<a href="#">197</a>
4	Frequency Detection 1	<a href="#">191</a>	37	During Frequency Output	<a href="#">197</a>
5	Frequency Detection 2	<a href="#">192</a>	38	Drive Enable	<a href="#">197</a>
6	Drive Ready	<a href="#">193</a>	39	Watt Hour Pulse Output	<a href="#">197</a>
7	DC Bus Undervoltage	<a href="#">193</a>	3A	Drive Overheat Alarm (oH2)	<a href="#">197</a>
8	During Baseblock (N.O.)	<a href="#">193</a>	3B	RUN Command from Option Card/Communications	<a href="#">197</a>
9	Frequency Reference Source	<a href="#">193</a>	3C	LOCAL/REMOTE Status	<a href="#">197</a>
A	Run Command Source	<a href="#">193</a>	3D	During Speed Search	<a href="#">197</a>
B	Torque Detection 1 (N.O.)	<a href="#">194</a>	3E	PI Feedback Low	<a href="#">197</a>
C	Frequency Reference Loss	<a href="#">194</a>	3F	PI Feedback High	<a href="#">198</a>
E	Fault	<a href="#">194</a>	4A	During KEB Operation	<a href="#">198</a>
F	Through Mode	<a href="#">194</a>	4B	During Short Circuit Braking	<a href="#">198</a>
10	Minor Fault	<a href="#">194</a>	4C	During Fast Stop	<a href="#">198</a>
11	Fault Reset Command Active	<a href="#">194</a>	4D	oH Pre-alarm Time Limit	<a href="#">198</a>
12	Timer Output	<a href="#">194</a>	50	Waiting for Run	<a href="#">198</a>
13	Speed Agree 2	<a href="#">194</a>	58	Underload Detection	<a href="#">198</a>
14	User-set Speed Agree 2	<a href="#">195</a>	60	Internal Cooling Fan Alarm	<a href="#">198</a>
15	Frequency Detection 3	<a href="#">195</a>	90	Driveworksez Digital Output 1	<a href="#">198</a>
16	Frequency Detection 4	<a href="#">195</a>	91	Driveworksez Digital Output 2	
17	Torque Detection 1 (N.C.)	<a href="#">194</a>	92	Driveworksez Digital Output 3	
1A	During Reverse	<a href="#">196</a>	100 to 192	Functions 0 to 92 with Inverse Output	<a href="#">198</a>
1B	During Baseblock (N.C.)	<a href="#">196</a>			

### Setting 0: During Run

Output closes when the drive is outputting a voltage.

Status	Description
Open	Drive is stopped.
Closed	A Run command is input or the drive is during deceleration or during DC injection.

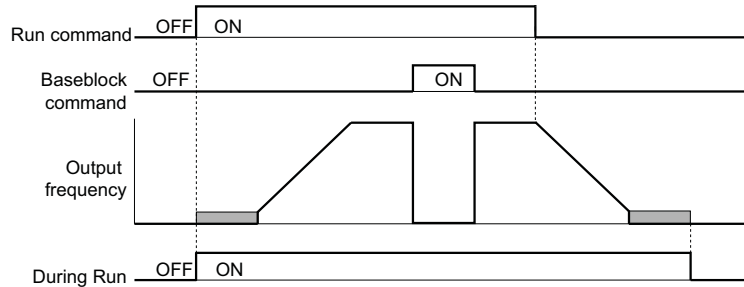


Figure 5.40 During Run Time Chart

**Setting 1: Zero Speed**

Terminal closes whenever the output frequency or motor speed falls below the minimum output frequency set to E1-09 or b2-01.

Status	Description
Open	Output frequency is above the minimum output frequency set to E1-09 or b2-01
Closed	Output frequency is less than the minimum output frequency set to E1-09 or b2-01

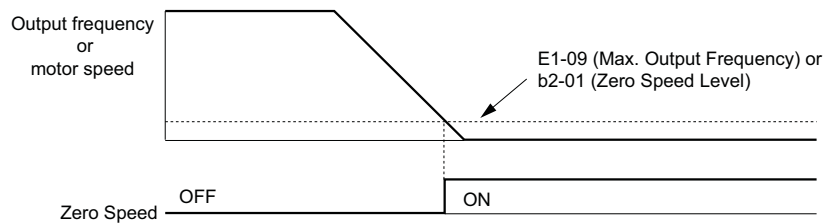


Figure 5.41 Zero-Speed Time Chart

**Setting 2: Speed Agree 1 ( $f_{ref} / f_{out}$  Agree 1)**

Closes whenever the actual output frequency is within the Speed Agree Width (L4-02) of the current frequency reference regardless of the direction.

Status	Description
Open	Output frequency or motor speed does not match the frequency reference while the drive is running.
Closed	Output frequency or motor speed is within the range of frequency reference $\pm L4-02$ .

**Note:** Detection works in both directions, forward and reverse.

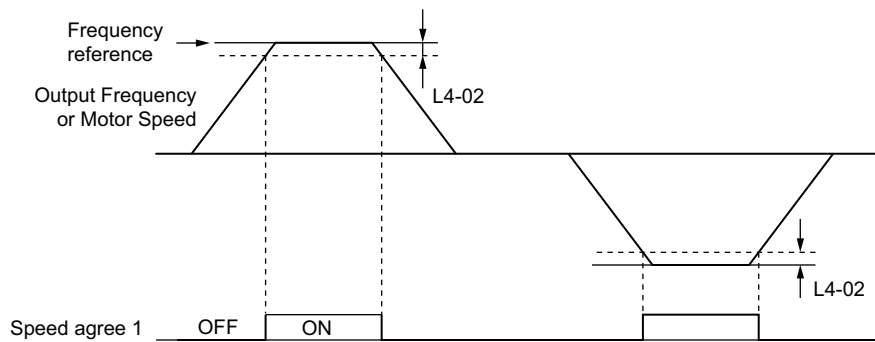


Figure 5.42 Speed Agree 1 Time Chart

*Refer to L4-01, L4-02: Speed Agreement Detection Level and Detection Width on page 227 for more details.*

**Setting 3: User-set Speed Agree 1 ( $f_{ref} / f_{set}$  Agree 1)**

Closes whenever the actual output frequency and the frequency reference are within the speed agree width (L4-02) of the programmed speed agree level (L4-01).

Status	Description
Open	Output frequency or motor speed and frequency reference are not both within the range of L4-01 $\pm L4-02$ .
Closed	Output frequency or motor speed and the frequency reference are both within the range of L4-01 $\pm L4-02$ .

**Note:** Frequency detection works in both forward and reverse. The value of L4-01 is used as the detection level for both directions.

## 5.7 H: Terminal Functions

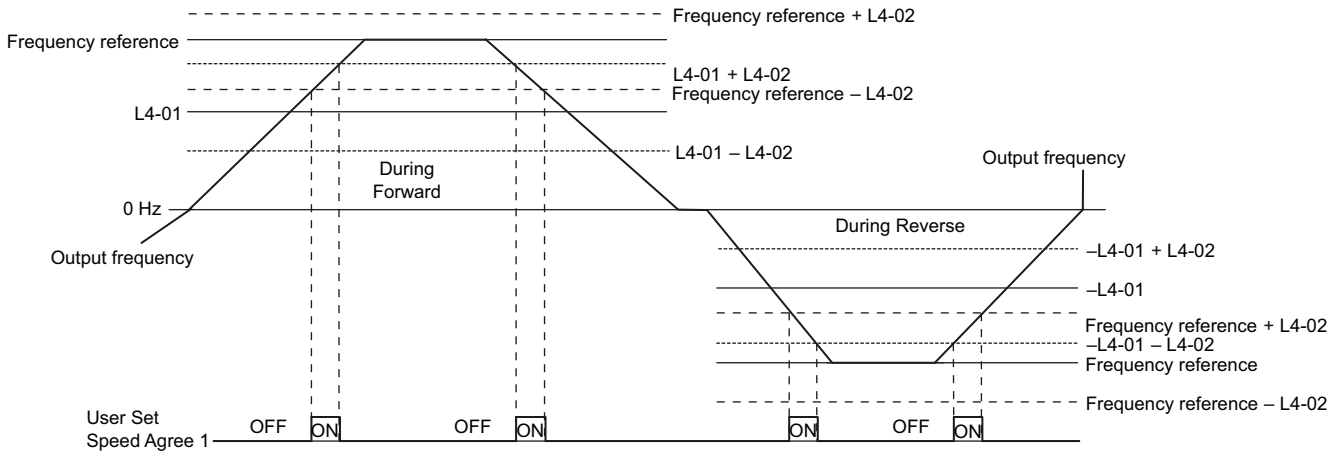


Figure 5.43 User Set Speed Agree 1 Time Chart

Refer to L4-01, L4-02: Speed Agreement Detection Level and Detection Width on page 227 for more instructions.

### Setting 4: Frequency Detection 1

Output opens when the output frequency rises above the detection level set in L4-01 plus the detection width set in L4-02. The terminal remains open until the output frequency falls below the level set in L4-01.

Status	Description
Open	Output frequency or motor speed exceeded L4-01 + L4-02.
Closed	Output frequency or motor speed is below L4-01 or has not exceeded L4-01 + L4-02.

**Note:** Frequency detection works in both forward and reverse. The value of L4-01 is used as the detection level for both directions.

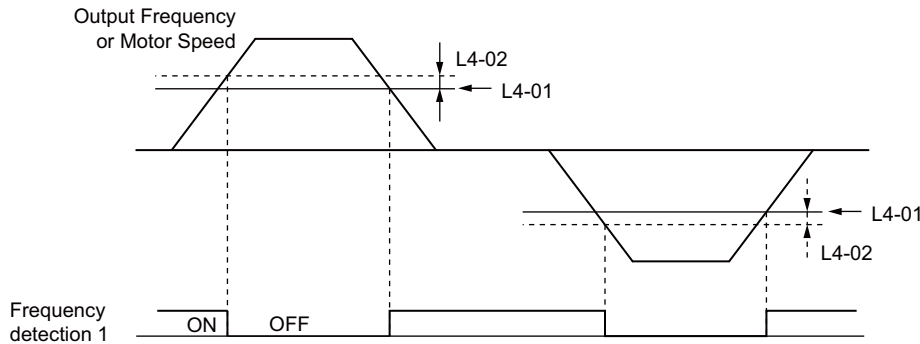


Figure 5.44 Frequency Detection 1 Time Chart

Refer to L4-01, L4-02: Speed Agreement Detection Level and Detection Width on page 227 for more details.

### Setting 5: Frequency Detection 2

Output closes whenever the output frequency is above the detection level set in L4-01. The terminal remains closed until the output frequency falls below L4-01 minus the setting of L4-02.

Status	Description
Open	Output frequency or motor speed is below L4-01 minus L4-02 or has not exceeded L4-01.
Closed	Output frequency or motor speed exceeded L4-01.

**Note:** Frequency detection works in both forward and reverse. The value of L4-01 is used as the detection level for both directions.



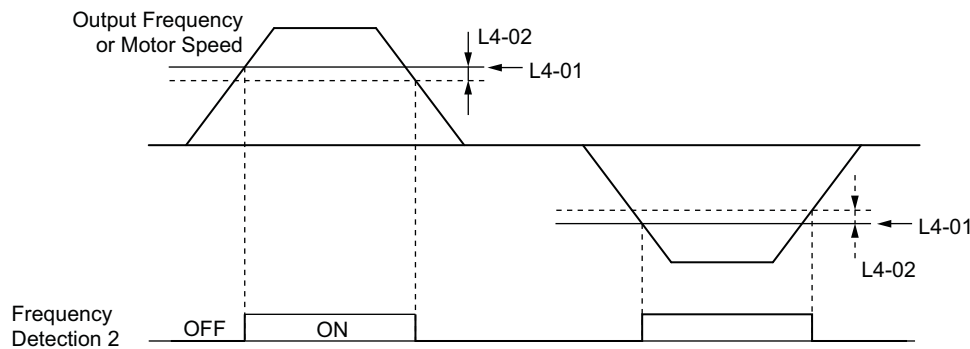


Figure 5.45 Frequency Detection 2 Time Chart

Refer to L4-01, L4-02: Speed Agreement Detection Level and Detection Width on page 227 for more details.

### Setting 6: Drive Ready

Output closes whenever the drive is ready to operate the motor. The terminal will not close under the conditions listed below, and any Run commands will be disregarded.

- When the power is shut off
- During a fault
- When the drive's internal power supply has malfunctioned
- When a parameter setting error makes it impossible to run
- Although stopped, an overvoltage or undervoltage situation occurs
- While editing a parameter in the Programming Mode (when b1-08 = 0)

### Setting 7: DC bus Undervoltage

Output closes whenever the DC bus voltage or control circuit power supply drops below the trip level set in L2-05. A fault in the DC bus circuit will also cause the terminal to set for "DC bus undervoltage" to close.

Status	Description
Open	DC bus voltage is above the level set to L2-05
Closed	DC bus voltage has fallen below the trip level set to L2-05.

### Setting 8: During Baseblock (N.O.)

Output closes to indicate that the drive is in a baseblock state. While in baseblock, output transistors do not switch and no main circuit voltage is output.

Status	Description
Open	Drive is not in a baseblock state.
Closed	Baseblock is being executed.

### Setting 9: Frequency Reference Source

A digital output programmed for this function shows the frequency reference source that is currently selected.

Status	Description
Open	Frequency reference is provided from External reference 1 (b1-01) or External reference 2 (b1-15)
Closed	Frequency reference is being sourced from the digital operator.

### Setting A: Run Command Source

A digital output programmed for this function shows the Run command source that is currently selected.

Status	Description
Open	Run command is provided from External reference 1 (b1-02) or 2 (b1-16).
Closed	Run command is being sourced from the digital operator.

## 5.7 H: Terminal Functions

### Setting B, 17: Torque Detection 1 (N.O., N.C.)

These digital output functions can be used to signal an overtorque or undertorque situation to an external device.

Set up the torque detection levels and select the output function from the table below. *Refer to L6: Torque Detection on page 231* for details.

Setting	Status	Description
B	Closed	Torque detection 1 (N.O.): Output current/torque exceeds (overtorque detection) or is below (undertorque detection) the torque value set in parameter L6-02 for longer than the time specified in parameter L6-03.
17	Open	Torque detection 1 (N.C.): Output current/torque exceeds (overtorque detection) or is below (undertorque detection) the torque value set in parameter L6-02 for longer than the time specified in parameter L6-03.

### Setting C: Frequency Reference Loss

An output set for this function will be closed if frequency reference loss is detected. *Refer to L4-05: Frequency Reference Loss Detection Selection on page 228* for details.

### Setting E: Fault

The digital output will close whenever the drive experiences a fault (this excludes faults CPF00 and CPF01).

### Setting F: Through Mode

Select this setting when using the terminal in a pass-through mode. When set to F, an output does not trigger any function in the drive. Setting F, however, still allows the output status to be read by a PLC via a communication option or MEMOBUS/Modbus communications.

### Setting 10: Minor Fault

Output closes when a minor fault condition is present.

### Setting 11: Fault Reset Command Active

Output closes whenever there is an attempt to reset a fault situation from the control circuit terminals, via serial communications, or using a communications option card.

### Setting 12: Timer Output

This setting configures a digital output terminal as output for the timer function. *Refer to b4: Delay Timers on page 144* for details.

### Setting 13: Speed Agree 2 ( $f_{ref} / f_{out}$ agree 2)

Closes whenever the actual output frequency or motor speed is within the speed agree width (L4-04) of the current frequency reference, regardless of the direction.

Status	Description
Open	Output frequency or motor speed does not match the frequency reference while the drive is running.
Closed	Output frequency or motor speed is within the range of frequency reference $\pm$ L4-04.

**Note:** Detection works in both forward and reverse.

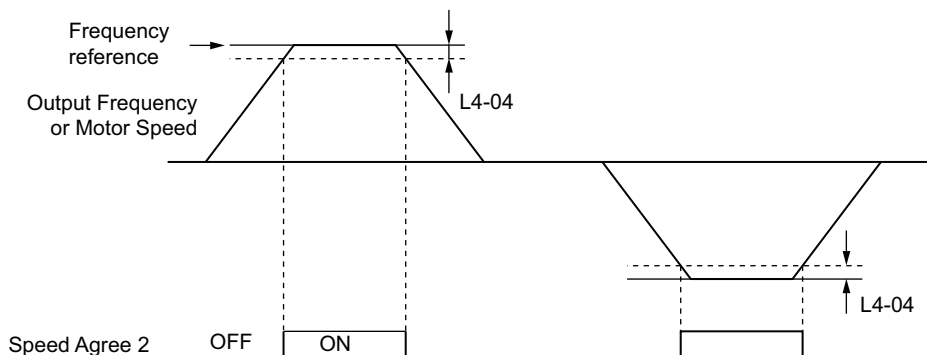


Figure 5.46 Speed Agree 2 Time Chart

*Refer to L4-03, L4-04: Speed Agreement Detection Level and Detection Width (+/-) on page 227* for more details.

**Setting 14: User-set Speed Agree 2 ( $f_{ref} / f_{set}$  agree 2)**

Closes whenever the actual output frequency or motor speed and the frequency reference are within the speed agree width (L4-04) of the programmed speed agree level (L4-03). As the detection level L4-03 is a signed value, detection works in the specified direction only.

Status	Description
Open	Output frequency or motor speed and frequency reference are both outside the range of $L4-03 \pm L4-04$
Closed	Output frequency or motor speed and the frequency reference are both within the range of $L4-03 \pm L4-04$

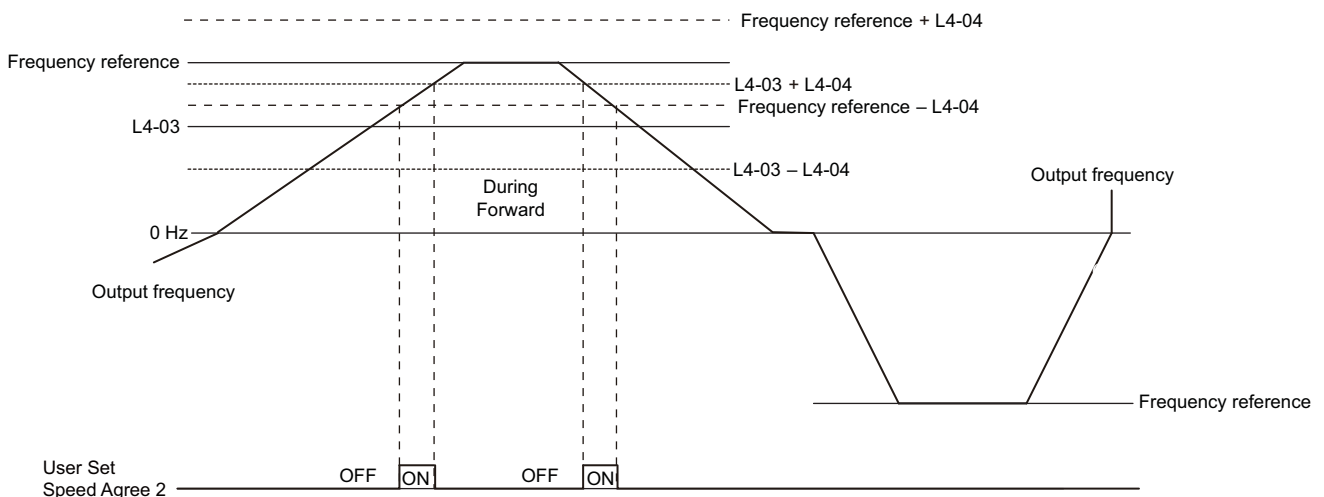


Figure 5.47 User Set Speed Agree 2 Example with a Positive L3-04 Value

Refer to L4-03, L4-04: Speed Agreement Detection Level and Detection Width (+/-) on page 227 for more details.

**Setting 15: Frequency Detection 3**

Output opens when the output frequency or motor speed rises above the detection level set in L4-03 plus the detection with set in L4-04. The terminal remains open until the output frequency or motor speed falls below the level set in L4-03. As the detection level L4-03 is a signed value, the detection works in the specified direction only.

Status	Description
Open	Output frequency or motor speed exceeded $L4-03$ plus $L4-04$ .
Closed	Output frequency or motor speed is below $L4-03$ or has not exceeded $L4-03$ plus $L4-04$ yet.

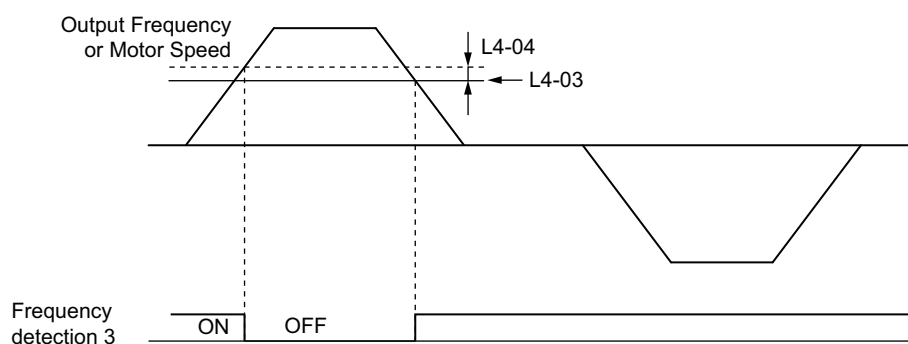


Figure 5.48 Frequency Detection 3 Example with a Positive L3-04 Value

Refer to L4-03, L4-04: Speed Agreement Detection Level and Detection Width (+/-) on page 227 for more details.

**Setting 16: Frequency Detection 4**

Output closes whenever the output frequency or motor speed is above the detection level set in L4-03. The terminal remains closed until the output frequency or motor speed falls below  $L4-03$  minus the setting of L4-04. As the detection level L4-03 is a signed value, frequency detection works in the specified direction only.

Status	Description
Open	Output frequency or motor speed is below $L4-03$ minus $L4-04$ or has not exceeded $L4-03$ yet.
Closed	Output frequency or motor speed exceeded $L4-03$ .

## 5.7 H: Terminal Functions

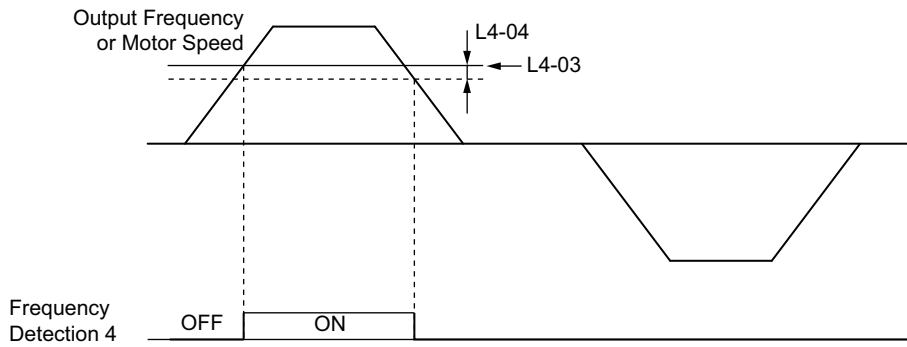


Figure 5.49 Frequency Detection 4 Example with Positive L3-04 Value

Refer to L4-03, L4-04: Speed Agreement Detection Level and Detection Width (+/-) on page 227 for more details.

### Setting 1A: During Reverse

A digital output set for “During reverse” will close whenever the drive is running the motor in the reverse direction.

Status	Description
Open	Motor is being driven in the forward direction or stopped.
Closed	Motor is being driven in reverse.

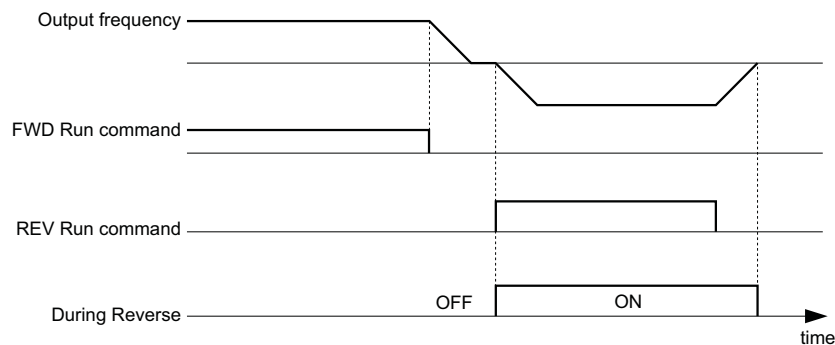


Figure 5.50 Reverse Direction Output Example Time Chart

### Setting 1B: During Baseblock (N.C.)

Output opens to indicate that the drive is in a baseblock state. While Baseblock is executed, output transistors do not switch and no main circuit voltage is output.

Status	Description
Open	Baseblock is being executed.
Closed	Drive is not in a baseblock state.

### Setting 1E: Restart Enabled

An output set for “Restart enabled” closes once the drive begins attempting to restart after a fault has occurred.

The fault restart function allows the drive to automatically clear a fault. The terminal set to 1E will close after the fault is cleared and the drive has begun attempting to restart. If the drive cannot successfully restart within the number of attempts permitted by L5-01, then a fault will be triggered and the terminal set to 1E will open. Refer to L5: Fault Restart on page 228 for details on automatic restart.

### Setting 1F: Motor Overload Alarm (oL1)

An output programmed for this function will close when the motor overload level estimated by the oL1 fault detection exceeds 90% of the oL1 detection level. Refer to L1-01: Motor Overload Protection Selection on page 209.

### Setting 20: Drive Overheat Pre-alarm (oH)

Output closes whenever the drive heatsink temperature reaches the level specified by parameter L8-02. Refer to L8-02: Overheat Alarm Level on page 233 for details on drive overheat detection.

**Setting 2F: Maintenance Period**

Output closes when the cooling fan, DC bus capacitors, or DC bus pre-charge relay may require maintenance as determined by the estimated performance life span of those components. Components performance life is displayed as a percentage on the digital operator screen. *Refer to Periodic Maintenance on page 301.*

**Setting 37: During Frequency Output**

Output closes when the drive is outputting a frequency.

Status	Description
Open	Drive is stopped or one of the following functions is being performed: baseblock, DC Injection Braking, Short Circuit Braking.
Closed	Drive is outputting frequency.

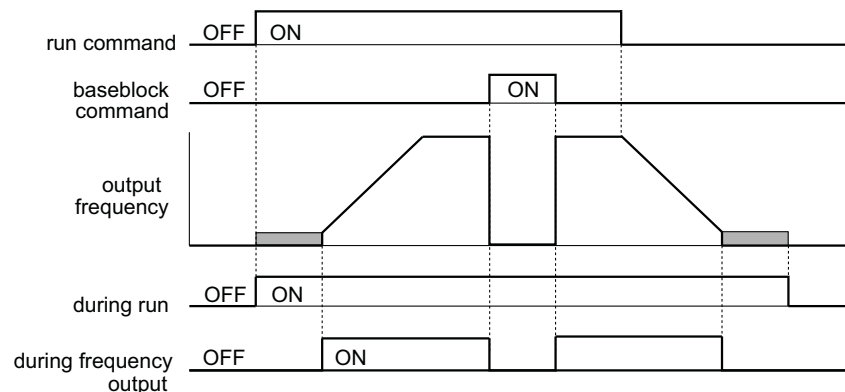


Figure 5.51 During Frequency Output Time Chart

**Setting 38: Drive Enable**

A digital output set for “Drive enable” will reflect the status of a digital input configured as a “Drive enable” input (H1-□□ = 6A). If that digital input closes, then the digital output set for “Drive enable” will also close.

**Setting 39: Watt Hour Pulse Output**

Outputs a pulse to indicate the watt hours. *Refer to H2-06: Watt Hour Output Unit Selection on page 198* for details.

**Setting 3A: Drive Overheat Alarm (oH2)**

Output closes when an external device triggered an overheat warning in the drive.

**Setting 3B: RUN Command from Option Card/Communications**

If a multi-function digital output is programmed to 3B the output will be switched ON when the RUN command is input from the built-in communication (MEMOBUS/Modbus) or from a communication option card (SI-S3, SI-N3, etc). If both RUN commands are off the output will be switched OFF.

Status	Description
Open	Run command is not input from the MEMOBUS/Modbus communication or a Communication option.
Closed	Run command is input from the MEMOBUS/Modbus communication or a Communication option.

**Setting 3C: LOCAL/REMOTE Status**

Output terminal closes while the drive is set for LOCAL and opens when in REMOTE.

Status	Description
Open	REMOTE: The external reference that has been selected (either b1-01 and b1-02 or b1-15 and b1-16) is used as frequency reference and Run command source
Closed	LOCAL: The digital operator is used as frequency reference and Run command source

**Setting 3D: During Speed Search**

Output terminal closes while Speed Search is being performed. *Refer to b3: Speed Search on page 139* for details.

**Setting 3E: PI Feedback Low**

Output terminal closes when a PI feedback loss is detected. The feedback is considered to be lost if it falls below the level set to b5-13 for longer than the time set to b5-14. *Refer to PI Feedback Loss Detection on page 149* for details.

## 5.7 H: Terminal Functions

### Setting 3F: PI Feedback High

Output terminal closes when a PI feedback loss is detected. The feedback is considered to be lost if it rises beyond the level set to b5-36 for longer than the time set to b5-37. *Refer to PI Feedback Loss Detection on page 149* for details.

### Setting 4A: During KEB Operation

Output terminal closes while KEB is being performed. *Refer to KEB Ride-Thru Function on page 215* for a KEB function description.

### Setting 4B: During Short Circuit Braking

Output terminal closes while Short Circuit Braking is being executed.

### Setting 4C: During Fast Stop

Output terminal closes when a Fast Stop is being executed. *Setting 15, 17: Fast Stop (N.O., N.C.) on page 185.*

### Setting 4D: oH Pre-alarm Time Limit

Output terminal closes when the drive is reducing the speed due to a drive overheat alarm (L8-03 = 4) and the overheat alarm has not disappeared after ten frequency reduction operation cycles. *Refer to L8-03: Overheat Pre-Alarm Operation Selection on page 234* for a more detailed description.

### Setting 50: Waiting for RUN (WrUn)

The Drive will delay executing any run command until the time set in b1-11 has expired.

### Setting 58: Underload Detection

Underload is detected when the output current falls below the underload detection level defined by L6-14 and L6-02.

### Setting 60: Internal Cooling Fan Alarm

Output closes when the drive's internal cooling fan has failed.

### Setting 90 to 92: DriveWorksEZ Digital Output 1 to 3

These settings are for output functions used in DriveWorksEZ. Normally there is no need to change these settings.

### Setting 100 to 192: Functions 0 to 92 with Inverse Output

These settings have the same function as settings 0 to 92 but with inverse output. Set as 1□□, where the "1" indicates inverse output and the last two digits specify the setting number of the function.

Examples:

- For inverse output of "8: During baseblock", set 108.
- For inverse output of "4A: During KEB" set 14A.

### ■ H2-06: Watt Hour Output Unit Selection

When one of the multi-function terminals is set to output the number of watt hours (H2-01, H2-02, or H2-03 = 39), parameter H2-06 determines the units for the output signal.

This output function provides a watt hour meter or a PLC input by a 200 ms pulse signal. H2-06 determines the frequency that pulses are issued to keep track of the kWh for the drive.

No.	Parameter Name	Setting Range	Default
H2-06	Watt Hour Output Unit Selection	0: 0.1 kWh units 1: 1 kWh units 2: 10 kWh units 3: 100 kWh units 4: 1000 kWh units	0

- Note:**
1. A negative power output (i.e., regeneration) does not subtract from the total watt hours.
  2. The drive keeps track of the watt hours as long as the control circuit has power. The value is reset when the power supply is shut off.

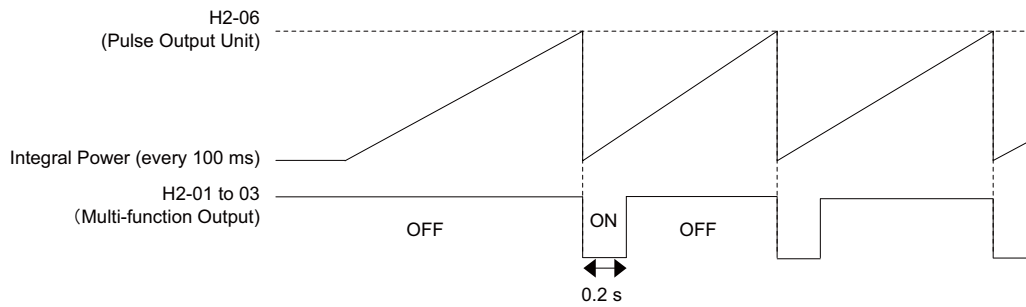


Figure 5.52 Watt Hour Output Example

### ◆ H3: Multi-Function Analog Inputs

The drive is equipped with three multi-function analog input terminals: A1, A2, and A3. See [Table 5.30](#) for a listing of the functions that can be set to these terminals.

#### ■ H3-01: Terminal A1 Signal Level Selection

Selects the input signal level for analog input A1.

No.	Name	Setting Range	Default
H3-01	Terminal A1 Signal Level Selection	0 to 1	0

##### Setting 0: 0 to 10 Vdc

The input level is 0 to 10 Vdc. The minimum input level is limited to 0%, so that a negative input signal due to gain and bias settings will be simply read as 0%.

##### Setting 1: -10 to 10 Vdc

The input level is -10 to 10 Vdc. If the resulting voltage is negative after being adjusted by gain and bias settings, then the motor will rotate in reverse.

#### ■ H3-02: Terminal A1 Function Selection

Selects the input signal level for analog input A3. [Refer to Multi-Function Analog Input Terminal Settings on page 202](#) for instructions on how to adjust the signal level.

No.	Name	Setting Range	Default
H3-02	Terminal A1 Function Selection	0 to 31	0

#### ■ H3-03, H3-04: Terminal A1 Gain and Bias Settings

Parameter H3-03 sets the level of the selected input value that is equal to 10 Vdc input at terminal A1 (gain).

Parameter H3-04 sets the level of the selected input value that is equal to 0 V input at terminal A1 (bias).

Both can be used to adjust the characteristics of the analog input signal to terminal A1.

No.	Name	Setting Range	Default
H3-03	Terminal A1 Gain Setting	-999.9 to 999.9%	100.0%
H3-04	Terminal A1 Bias Setting	-999.9 to 999.9%	0.0%

## 5.7 H: Terminal Functions

### Setting Examples

- Gain H3-03 = 200%, bias H3-04 = 0, terminal A1 as frequency reference input (H3-02 = 0):

An input 10 Vdc will be equivalent to a 200% frequency reference and 5 Vdc will be equivalent to a 100% frequency reference. Since the drive output is limited by the maximum frequency parameter (E1-04), the frequency reference will be equal to E1-04 above 5 Vdc.

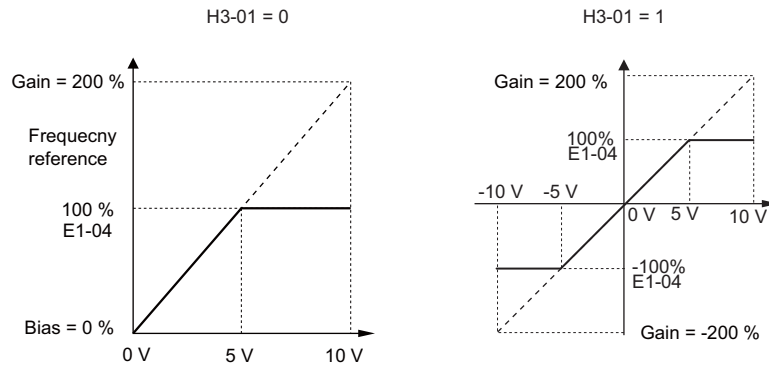


Figure 5.53 Frequency Reference Setting by Analog Input with Increased Gain

- Gain H3-03 = 100%, bias H3-04 = -25%, terminal A1 as frequency reference input:

An input of 0 Vdc will be equivalent to a -25% frequency reference.

When parameter H3-01 = 0, the frequency reference is 0% between 0 and 2 Vdc input.

When parameter H3-01 = 1, the motor will rotate in reverse between -10 and 2 Vdc input.

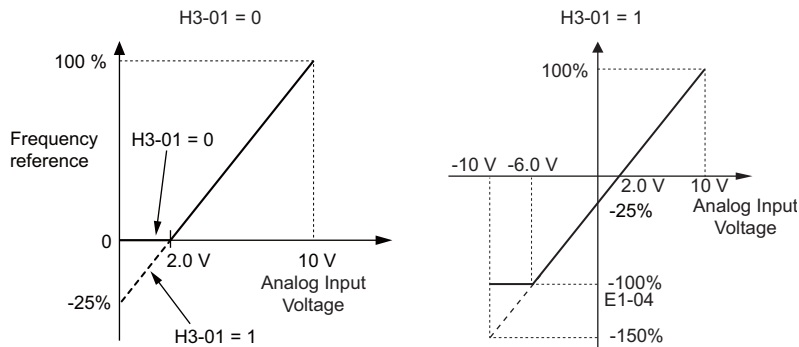


Figure 5.54 Frequency Reference Setting by Analog Input with Negative Bias

### ■ H3-05: Terminal A3 Signal Level Selection

Determines the function assigned to analog input terminal A3. [Refer to Multi-Function Analog Input Terminal Settings on page 202](#) for a list of functions and descriptions.

No.	Name	Setting Range	Default
H3-05	Terminal A3 Signal Level Selection	0, 1	0

#### Setting 0: 0 to 10 Vdc

The input level is 0 to 10 Vdc. See the explanation provided for H3-01. [Refer to Setting 0: 0 to 10 Vdc on page 199.](#)

#### Setting 1: -10 V to 10 Vdc

The input level is -10 to 10 Vdc. See the explanation provided for H3-01. [Refer to Setting 1: -10 to 10 Vdc on page 199.](#)

### ■ H3-06: Terminal A3 Function Selection

Determines the function assigned to analog input terminal A3. [Refer to Multi-Function Analog Input Terminal Settings on page 202](#) for a list of functions and descriptions.

No.	Name	Setting Range	Default
H3-06	Terminal A3 Function Selection	0 to 31	2



### ■ H3-07, H3-08: Terminal A3 Gain and Bias Setting

Parameter H3-07 sets the level of the selected input value that is equal to 10 Vdc input at terminal A3 (gain).

Parameter H3-08 sets the level of the selected input value that is equal to 0 V input at terminal A3 (bias).

No.	Name	Setting Range	Default
H3-07	Terminal A3 Gain Setting	-999.9 to 999.9%	100.0%
H3-08	Terminal A3 Bias Setting	-999.9 to 999.9%	0.0%

### ■ H3-09: Terminal A2 Signal Level Selection

Selects the input signal level for analog input A2. Be sure to also set DIP switch S1 on the terminal board accordingly for a voltage input or current input.

No.	Name	Setting Range	Default
H3-09	Terminal A2 Signal Level Selection	0 to 3	2

#### Setting 0: 0 to 10 Vdc

The input level is 0 to 10 Vdc. *Refer to Setting 0: 0 to 10 Vdc on page 199*

#### Setting 1: -10 to 10 Vdc

The input level is -10 to 10 Vdc. *Refer to Setting 1: -10 to 10 Vdc on page 199.*

#### Setting 2: 4 to 20 mA Current Input

The input level is 4 to 20 mA. Negative input values by negative bias or gain settings will be limited to 0%.

#### Setting 3: 0 to 20 mA Current Input

The input level is 0 to 20 mA. Negative input values by negative bias or gain settings will be limited to 0%.

### ■ H3-10: Terminal A2 Function Selection

Determines the function assigned to analog input terminal A2. *Refer to Multi-Function Analog Input Terminal Settings on page 202* for a list of functions and descriptions.

No.	Name	Setting Range	Default
H3-10	Terminal A2 Function Selection	0 to 31	0

### ■ H3-11, H3-12: Terminal A2 Gain and Bias Setting

Parameter H3-11 sets the level of the input value selected that is equal to 10 Vdc input or 20 mA input to terminal A2.

Parameter H3-12 sets the level of the input value selected that is equal to 0 V, 4 mA or 0 mA input at terminal A2.

Both can be used to adjust the characteristics of the analog input signal to terminal A2. The setting works in the same way as parameters H3-03 and H3-04 for analog input A1.

No.	Name	Setting Range	Default
H3-11	Terminal A2 Gain Setting	-999.9 to 999.9%	100.0%
H3-12	Terminal A2 Bias Setting	-999.9 to 999.9%	0.0%

### ■ H3-13: Analog Input Filter Time Constant

Parameter H3-13 sets the time constant for a first order filter that will be applied to the analog inputs.

An analog input filter can be used to prevent erratic drive control when a “noisy” analog reference is used. The drive operation becomes more stable the longer the time programmed, but it becomes less responsive to rapidly changing analog signals.

No.	Name	Setting Range	Default
H3-13	Analog Input Filter Time Constant	0.00 to 2.00 s	0.03 s

## 5.7 H: Terminal Functions

### ■ H3-14: Analog Input Terminal Enable Selection

When one of the multi-function digital input parameters is set for “Analog input enable” (H1-□□ = C), the value set to H3-14 determines which analog input terminals are enabled and which terminals are disabled when the input is closed. All analog input terminals will be enabled all of the time if H1-□□ is not set to C.

No.	Name	Setting Range	Default
H3-14	Analog Input Terminal Enable Selection	1 to 7	7

**Setting 1: A1 only enabled**

**Setting 2: A2 only enabled**

**Setting 3: A1 and A2 only enabled**

**Setting 4: A3 only enabled**

**Setting 5: A1 and A3 only enabled**

**Setting 6: A2 and A3 only enabled**

**Setting 7: All analog input terminals enabled**

### ■ H3-16 to H3-18 Terminal A1/A2/A3 Offset

Parameters H3-16 to H3-18 set the offset level of the selected input value to terminal A1, A2 or A3 that is equal to 0 Vdc input. These parameters rarely need adjustment.

No.	Name	Setting Range	Default
H3-16	Terminal A1 Offset	-500 to 500	0
H3-17	Terminal A2 Offset	-500 to 500	0
H3-18	Terminal A3 Offset	-500 to 500	0

### ■ Multi-Function Analog Input Terminal Settings

See [Table 5.30](#) for information on how H3-02, H3-10, and H3-06 determine functions for terminals A1, A2, and A3.

**Note:** The scaling of all input functions depends on the gain and bias settings for the analog inputs. Set these to appropriate values when selecting and adjusting analog input functions.

**Table 5.30 Multi-Function Analog Input Terminal Settings**

Setting	Function	Page	Setting	Function	Page
0	Frequency Bias	<a href="#">202</a>	C	PI Setpoint	<a href="#">204</a>
1	Frequency Gain	<a href="#">203</a>	D	Frequency Bias	<a href="#">204</a>
2	Auxiliary Frequency Reference 1	<a href="#">203</a>	E	Motor Temperature (PTC input: A3 only)	<a href="#">204</a>
3	Auxiliary Frequency Reference 2	<a href="#">203</a>	F	Through Mode	<a href="#">204</a>
4	Output Voltage Bias	<a href="#">203</a>	16	Differential PI Feedback	<a href="#">204</a>
5	Accel/Decel Time Gain	<a href="#">203</a>	17 <I>	Motor Thermistor (NTC)	<a href="#">204</a>
6	DC Injection Braking Current	<a href="#">203</a>	1F	Through Mode	<a href="#">204</a>
7	Torque Detection Level	<a href="#">203</a>	30	DriveWorksEZ Analog Input 1	<a href="#">204</a>
8	Stall Prevention Level During Run	<a href="#">204</a>	31	DriveWorksEZ Analog Input 2	
9	Output Frequency Lower Limit Level	<a href="#">204</a>	32	DriveWorksEZ Analog Input 3	
B	PI Feedback	<a href="#">204</a>	–	–	–

<I> This function is available in models CIMR-E□4A0930 and 4A1200.

#### Setting 0: Frequency Bias

The input value of an analog input set to this function will be added to the analog frequency reference value. When the frequency reference is supplied by a different source other than the analog inputs, this function will have no effect. Use this setting also when only one of the analog inputs is used to supply the frequency reference.

By default, analog inputs A1 and A2 are set for this function. Using A1 and A2 at the same time increases the frequency reference by the total of all inputs.

Example: If the analog frequency reference from analog input terminal A1 is 50% and a bias of 20% is applied by analog input terminal A2, the resulting frequency reference will be 70% of the maximum output frequency.

**Setting 1: Frequency Gain**

The input value of an analog input set to this function will be multiplied with the analog frequency reference value.

Example: If the analog frequency reference from analog input terminal A1 is 80% and a gain of 50% is applied from analog input terminal A2, the resulting frequency reference will be 40% of the maximum output frequency.

**Setting 2: Auxiliary Reference 1**

Sets the auxiliary frequency reference 1 when multi-step speed operation is selected. *Refer to Multi-Step Speed Selection on page 165* for details.

**Setting 3: Auxiliary Reference 2**

Sets the auxiliary frequency reference 2 when multi-step speed operation is selected. *Refer to Multi-Step Speed Selection on page 165* for details.

**Setting 4: Output Voltage Bias**

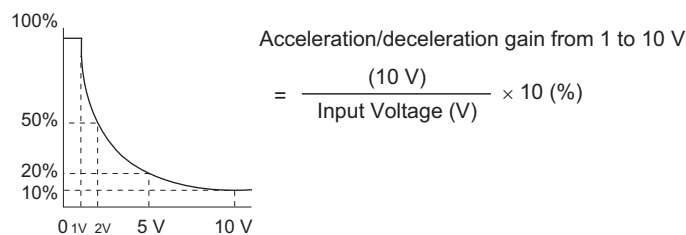
Voltage bias boosts the output voltage of the V/f curve as a percentage of the maximum output voltage (E1-05). Available only when using V/f Control.

**Setting 5: Accel/Decel Time Gain**

Adjusts the gain level for the acceleration and deceleration times set to parameters C1-01 through C1-04.

The acceleration time used by the drive is calculated by multiplying the this gain level to C1-□□ as follows:

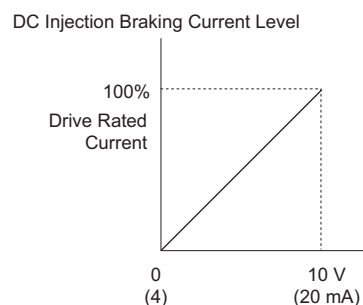
$C1-□□ \times \text{Accel/decel time gain} = \text{Drive accel/decel time}$



**Figure 5.55 Accel/Decel Time Gain with Analog Input Terminal**

**Setting 6: DC Injection Braking Current**

The current level used for DC Injection Braking. Set as a percentage of the maximum output current using.



**Figure 5.56 DC Injection Braking Current Using an Analog Input Terminal**

**Setting 7: Torque Detection Level**

Using this setting, the overtorque/undertorque detection level for torque detection 1 (L6-01) can be set by an analog input. The analog input will replace the level set to L6-02. An analog input of 100% (10 V or 20 mA) will set a torque detection level equal to 100% drive rated current / motor rated torque. Adjust the analog input gain if higher detection level settings are required. *Refer to L6: Torque Detection on page 231* for details on torque detection.

### Setting 8: Stall Prevention Level During Run

This setting allows an analog input signal to adjust the Stall Prevention level. [Figure 5.57](#) shows the setting characteristics. The drive will use either the Stall Prevention level set to L3-06 or the level coming from the analog input terminal that has been selected, whichever value is lower.

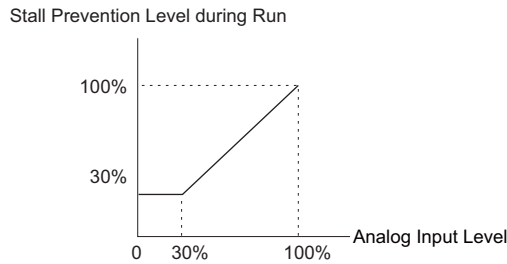


Figure 5.57 Stall Prevention During Run Using an Analog Input Terminal

### Setting 9: Output Frequency Lower Limit Level

The user can adjust the lower limit of the output frequency using an analog input signal.

### Setting B: PI Feedback

An input set for this function supplies the PI feedback value. This setting requires PI operation to be enabled in b5-01. [Refer to PI Feedback Input Methods on page 146.](#)

### Setting C: PI Setpoint

An input set for this function supplies the PI setpoint value, and the frequency reference selected in parameter b1-01 is no longer the PI setpoint. PI operation to be enabled in b5-01 to use this setting. [Refer to PI Setpoint Input Methods on page 146.](#)

### Setting D: Frequency Bias

The input value of an analog input set to this function will be added to the frequency reference. This function can be used with any frequency reference source.

### Setting E: Motor Temperature (PTC input: A3 only)

In addition to motor overload fault detection oL1, it is possible to use a PTC (Positive Temperature Coefficient) thermistor for motor insulation protection. Connect the PTC to analog input terminal A3, and set switch S4 on the terminal board to PTC. Refer to Terminal A3 Analog/PTC Input Selection on page 125 for details on setting S4. [Refer to Motor Protection Using a Positive Temperature Coefficient \(PTC\) on page 211](#) for further explanation.

### Setting F, 1F: Through Mode

When set to F or 1F, an input does not affect any drive function, but the input level can still be read out by a PLC via a communication option or MEMOBUS/Modbus communications.

### Setting 16: Differential PI Feedback

If an analog value is set for this function, the PI controller is set for differential feedback. The subtraction of the PI feedback input value and the differential feedback input value builds the feedback value that is used to calculate the PI input. [Refer to PI Feedback Input Methods on page 146.](#)

### Setting 17: Motor Thermistor (NTC)

Used as a complement or a substitution for oL1. [Refer to Motor Protection Using an NTC Thermistor Input on page 212.](#)

### Setting 30, 31, 32: DriveWorksEZ Analog Input 1, 2, 3

These settings are for functions used in DriveWorksEZ. Normally there is no need to change or apply these settings.

## ◆ H4: Multi-Function Analog Outputs

These parameters assign functions to analog output terminals FM and AM for monitoring a specific aspect of drive performance.

### ■ H4-01, H4-04: Multi-Function Analog Output Terminal FM, AM Monitor Selection

Sets the desired drive monitor parameter  $U\Box-\Box\Box$  to output as an analog value via terminal FM and AM. *Refer to U: Monitor Parameters on page 253* for a list of all monitors. The “Analog Output Level” column indicates if a monitor can be used for analog output.

Example: Enter “103” for U1-03.

No.	Name	Setting Range	Default
H4-01	Multi-Function Analog Output Terminal FM Monitor Selection	000 to 999	102
H4-04	Multi-Function Analog Output Terminal AM Monitor Selection	000 to 999	103

A setting of 031 or 000 applies no drive monitor to the analog output. With this setting, terminal functions as well as FM and AM output levels can be set by a PLC via a communication option or MEMOBUS/Modbus (through mode).

### ■ H4-02, H4-03: Multi-Function Analog Output Terminal FM Gain and Bias H4-05, H4-06: Multi-Function Analog Output Terminal AM Gain and Bias

Parameter H4-02 and H4-05 set the terminal FM and AM output signal level equal to 100% of the monitor (gain). Parameter H4-03 and H4-06 set the bias added to the monitor output for terminals FM and AM. Both are set as a percentage, where 100% equals 10 Vdc analog output. The output voltage of both terminals is limited to 10 Vdc.

The output signal range can be selected between 0 to +10 Vdc or -10 to +10 Vdc using parameter H4-07 and H4-08. *Figure 5.58* illustrates how gain and bias settings work.

No.	Name	Setting Range	Default
H4-02	Multi-Function Analog Output Terminal FM Gain	-999.9 to 999.9%	100.0%
H4-03	Multi-Function Analog Output Terminal FM Bias	-999.9 to 999.9%	0.0%
H4-05	Multi-Function Analog Output Terminal AM Gain	-999.9 to 999.9%	50.0%
H4-06	Multi-Function Analog Output Terminal AM Bias	-999.9 to 999.9%	0.0%

### Using Gain and Bias to Adjust Output Signal Level

The output signal is adjustable while the drive is stopped.

#### Terminal FM

1. View the value set to H4-02 (Terminal FM Monitor Gain) on the digital operator. A voltage equal to 100% of the parameter being set in H4-01 will be output from terminal FM.
2. Adjust H4-02 viewing the monitor connected to the terminal FM.
3. View the value set to H4-03 on the digital operator, terminal FM will output a voltage equal to 0% of the parameter being set in H4-01.
4. Adjust H4-03 viewing the output signal on the terminal FM.

#### Terminal AM

1. View the value set to H4-05 (Terminal AM Monitor Gain) on the digital operator. A voltage equal to 100% of the parameter being set in H4-04 will be output from terminal AM.
2. Adjust H4-05 viewing the monitor connected to the terminal AM.
3. View the value set to H4-06 on the digital operator, terminal AM will output a voltage equal to 0% of the parameter being set in H4-04.
4. Adjust H4-06 viewing the output signal on the terminal AM.

Example 1: To have an output signal of 5 V at terminal FM when the monitored value is at 100%, set H4-02 to 50%.

Example 2: To have an output signal of 10 V at terminal FM when the monitored value is at 76.7%, set H4-02 to 150%.

## 5.7 H: Terminal Functions

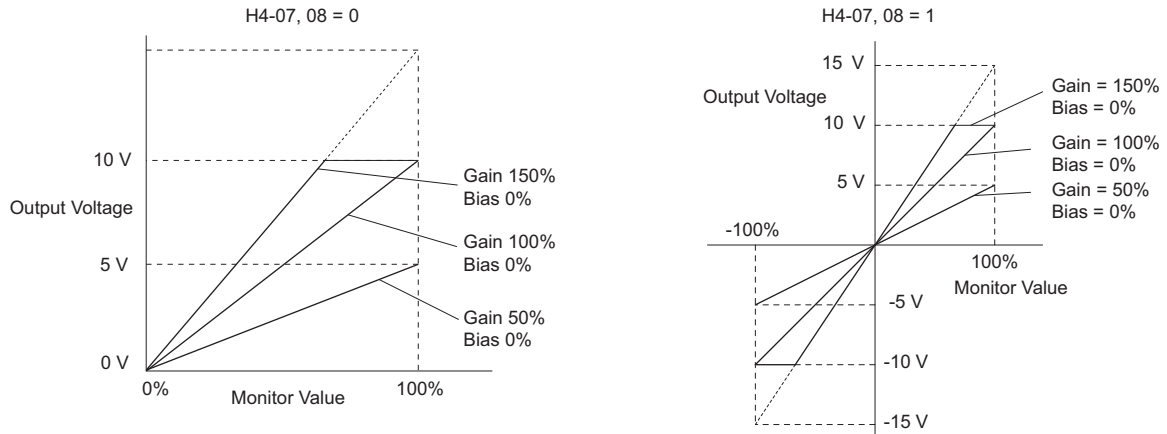


Figure 5.58 Analog Output Gain and Bias Setting Example 1 and 2

Example 3: To have an output signal of 3 V at terminal FM when the monitored value is at 0%, set H4-03 to 30%.

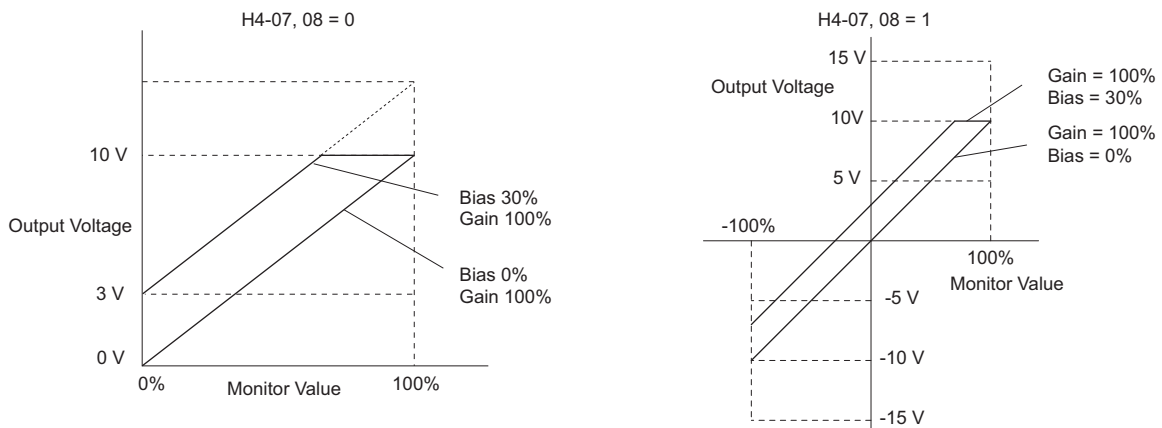


Figure 5.59 Analog Output Gain and Bias Setting Example 3

### ■ H4-07, H4-08: Multi-Function Analog Output Terminal FM, AM Signal Level Selection

Sets the voltage output level of U parameter (monitor parameter) data to terminal FM and terminal AM using parameters H4-07 and H4-08.

No.	Name	Setting Range	Default
H4-07	Multi-Function Analog Output Terminal FM Signal Level Selection	0 to 2	0
H4-08	Multi-Function Analog Output Terminal AM Signal Level Selection	0 to 2	0

Setting 0: 0 to 10 V

Setting 1: -10 V to 10 V

Setting 2: 4 to 20 mA

### ◆ H5: MEMOBUS/Modbus Serial Communication

Through the drives built in RS-422/RS-485 port (terminals R+, R-, S+, S-), serial communication is possible using programmable logic controllers (PLCs) or similar devices running the MEMOBUS/Modbus protocol.

The H5-□□ parameters are used to set up the drive for MEMOBUS/Modbus Communications. [Refer to MEMOBUS/Modbus Serial Communication on page 416](#) for detailed descriptions of the H5-□□ parameters.

### ◆ H6: Pulse Train Input/Output

A one track pulse train signal with a maximum frequency of 32 kHz can be input to the drive at terminal RP. This pulse train signal can be used as the frequency reference, for PI functions, or as the speed feedback signal in V/f Control.

The pulse output monitor terminal MP can output drive monitor values as a pulse train signal with a maximum frequency of 32 kHz. It can be used in sinking or sourcing mode. [Refer to Using the Pulse Train Output on page 86](#) for details.

Use parameters H6-□□ to set the scale and other aspects of the pulse input terminal RP and pulse output terminal MP.

### ■ H6-01: Pulse Train Input Terminal RP Function Selection

Selects the function of pulse train input terminal RP.

No.	Name	Setting Range	Default
H6-01	Pulse Train Input Terminal RP Function Selection	0 to 2	0

#### Setting 0: Frequency reference

If the pulse input is set for this function and the frequency reference source is set to pulse input (b1-01, b1-15 = 4), the drive reads the frequency value from terminal RP.

#### Setting 1: PI feedback value

Using this setting, the feedback value for PI control can be supplied as a pulse signal at terminal RP. [Refer to b5: PI Control on page 145](#) for details on PI control.

#### Setting 2: PI setpoint value

Using this setting, the setpoint value for PI control can be supplied as a pulse signal at terminal RP. [Refer to b5: PI Control on page 145](#) for details on PI control.

### ■ H6-02: Pulse Train Input Scaling

This parameter sets the pulse signal frequency that is equal to 100% of the input value selected in parameter H6-01.

No.	Name	Setting Range	Default
H6-02	Pulse Train Input Scaling	100 to 32000 Hz	1440 Hz

### ■ H6-03: Pulse Train Input Gain

Sets the level of the input value selected in H6-01 when a pulse train signal with the frequency set in H6-02 is input to terminal RP.

No.	Name	Setting Range	Default
H6-03	Pulse Train Input Gain	0.0 to 1000.0%	100.0%

### ■ H6-04: Pulse Train Input Bias

Sets the level of the input value selected in H6-01 when no signal (0 Hz) is input to terminal RP.

No.	Name	Setting Range	Default
H6-04	Pulse Train Input Bias	-100.0 to 100.0%	0.0%

### ■ H6-05: Pulse Train Input Filter Time

Sets the pulse train input filter time constant in seconds.

No.	Name	Setting Range	Default
H6-05	Pulse Train Input Filter Time	0.00 to 2.00 s	0.10 s

### ■ H6-06: Pulse Train Monitor Selection

Selects the monitor to output as a pulse train signal via terminal MP. Indicate which monitor to output entering the three digits in U□-□□. [Refer to U: Monitor Parameters on page 253](#) for a complete list of monitors. Monitors that can be selected by H6-06 appear in the table below.

No.	Name	Setting Range	Default
H6-06	Pulse Train Monitor Selection	000 <I>, 031, 101, 102, 105, 116, 501, 502, 702 to 711, 801 to 809	102

<I> Set "000" when the terminal is not used, or when using the terminal in the through mode.

### ■ H6-07: Pulse Train Monitor Scaling

Pulse train monitor scaling sets the output frequency at terminal MP when the specified monitor item is at 100%. Set H6-06 to 102 and H6-07 to 0 to make the pulse train monitor output synchronous to the output frequency.

No.	Name	Setting Range	Default
H6-07	Pulse Train Monitor Scaling	0 to 32000 Hz	1440 Hz

### ■ H6-08: Pulse Train Input Minimum Frequency

Sets the minimum output frequency that can be detected by the pulse train input. Increasing this setting reduces the time the drive needs to react to changes in the input signal.

- If the pulse input frequency falls below this level, the pulse input value will be 0.
- Enabled when H6-01 = 0, 1, or 2.

No.	Name	Setting Range	Default
H6-08	Pulse Train Input Minimum Frequency	0.1 to 1000.0 Hz	0.5 Hz



## 5.8 L: Protection Functions

### ◆ L1: Motor Protection

#### ■ L1-01: Motor Overload Protection Selection

The drive has an electronic overload protection function that estimates the motor overload level based on output current, output frequency, thermal motor characteristics, and time. An oL1 fault will be triggered when motor overload is detected and drive output will be shut off.

L1-01 sets the overload protection function characteristics according to the motor being used.

No.	Name	Setting Range	Default
L1-01	Motor Overload Protection Selection	0, 1, 4	Determined by A1-02

- Note:**
1. When the motor protection function is enabled (L1-01 ≠ 0), an oL1 alarm can be output through one of the multi-function outputs by setting H2-01 to 1F. The output will close when the motor overload level reaches 90% of the oL1 detection level.
  2. Select a method to protect the motor from overheat by setting L1-01 when running a single motor from the drive. An external thermal relay is not needed.

#### Setting 0: Disabled (motor overload protection is not provided)

This setting should be used if no motor overheat protection is desired or if multiple motors are connected to a single drive. In this case it is recommended that you install a thermal relay for each motor as shown in [Figure 5.60](#)

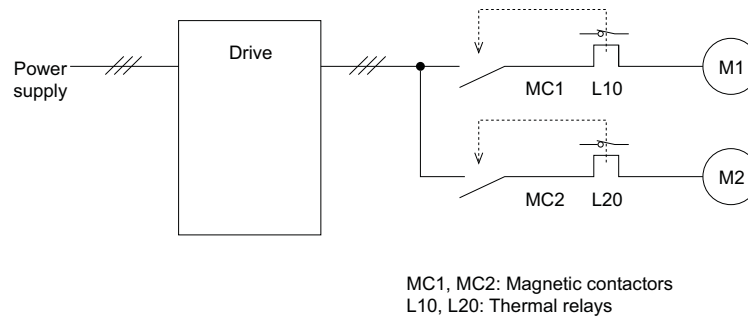


Figure 5.60 Example of Protection Circuit Design for Multiple Motors

**NOTICE:** Thermal protection cannot be provided when running multi-motors simultaneously with the same drive, or when using motors with a current rating that is relatively high when compared with other standard motors (such as a submersible motor). Failure to comply could result in motor damage. Disable the electronic overload protection of the drive (L1-01 = "0: Disabled") and protect each motor with individual motor thermal overloads.

**NOTICE:** Close MC1 and MC2 before operating the drive. (MC1 and MC2 cannot be switched off during run.)

#### Setting 1: Standard Fan Cooled (< 10:1 motor)

Because the motor is self-cooled, the overload tolerance drops when the motor speed is lowered. The drive appropriately adjusts the electrothermal trigger point according to the motor overload characteristics, protecting the motor from overheat throughout the entire speed range.

Overload Tolerance	Cooling Ability	Overload Characteristics
<p>Rated Speed=100% Speed 60 s A: Max. speed for 200LJ and above B: Max. speed for 160MJ to 180 LJ C: Max. speed for 132MJ and below</p> <p>Torque (%) Speed (%)</p>	<p>Motor designed to operate from line power. Motor cooling is most effective when running at rated base frequency (check the motor nameplate or specifications).</p>	<p>Continuous operation at less than line power frequency with 100% load can trigger motor overload protection (oL1). A fault is output and the motor will coast to stop.</p>

## 5.8 L: Protection Functions

### Setting 4: PM motor with variable torque

This setting is for operating a PM motor. PM motors for derated torque have a self-cooling design, so the overload tolerance drops as the motor slows. Electronic thermal overload is triggered in accordance with the motor overload characteristics, providing overheat protection across the entire speed range.

Overload Tolerance	Cooling Ability	Overload Characteristics
	<p>Motor is designed to produce 100% torque at base speed. Built with effective cooling capabilities.</p>	<p>Reaching 100% when operating at below the base frequency will cause a motor overload fault (oL1). The drive fault output closes and the motor coasts to stop.</p>

### Setting 6: General-purpose motor (50 Hz)

Because the motor (50 Hz) is self-cooled, the overload tolerance drops when the motor speed is lowered. The drive appropriately adjusts the electrothermal trigger point according to the motor overload characteristics, protecting the motor from overheat throughout the entire speed range.

Overload Tolerance	Cooling Ability	Overload Characteristics
<p>Rated Speed=100% Speed</p> <p>A: Max. speed for 200LJ and above            B: Max. speed for 160MJ to 180 LJ            C: Max. speed for 132MJ and below</p>	<p>Motor designed to operate from line power. Motor cooling is most effective when running at rated base frequency (check the motor nameplate or specifications).</p>	<p>Continuous operation at less than line power frequency with 100% load can trigger motor overload protection (oL1). A fault is output and the motor will coast to stop.</p>

### ■ L1-02: Motor Overload Protection Time

Sets the time it takes the drive to detect motor overheat due to overload. This setting rarely requires adjustment, but should correlate with the motor overload tolerance protection time for performing a hot start.

No.	Name	Setting Range	Default
L1-02	Motor Overload Protection Time	0.1 to 5.0 minutes	1.0 minutes

Defaulted to operate with an allowance of 150% overload operation for one minute in a hot start.

**Figure 5.61** shows an example of the electrothermal protection operation time using a general-purpose motor operating at 60 Hz with L1-02 set to one minute.

During normal operation, motor overload protection operates in the area between a cold start and a hot start.

- Cold start: Motor protection operation time in response to an overload situation that was suddenly reached when starting a stationary motor.
- Hot start: Motor protection operation time in response to an overload situation that occurred during sustained operation at rated current.

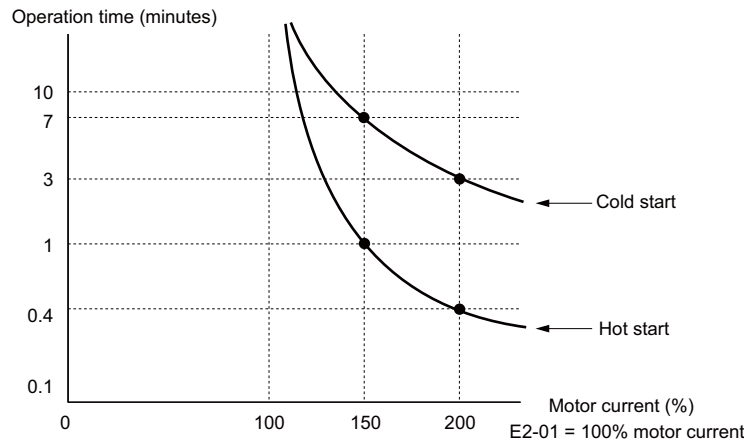


Figure 5.61 Motor Protection Operation Time

### Motor Protection Using a Positive Temperature Coefficient (PTC)

A motor PTC can be connected to an analog input of the drive. This input is used by the drive for motor overload protection.

When the PTC input signal reaches the motor overload alarm level, an oH3 alarm will be triggered and the drive will continue operation as selected in L1-03. When the PTC input signal reaches the overload fault level, an oH4 fault will be triggered, a fault signal will be output, and the drive will stop the motor using the stop method determined in L1-04.

Figure 5.62 shows a PTC connection example for analog input A2. If using analog input A2, make sure to set DIP switch S1 on the terminal board for voltage input when using this function.

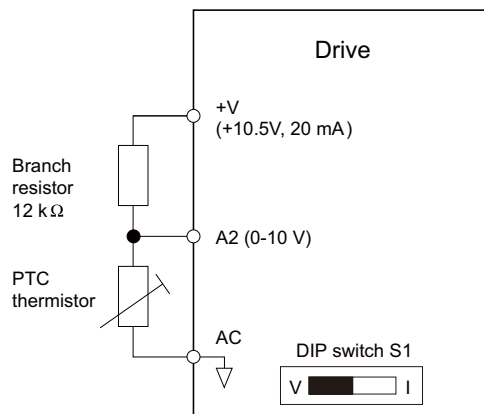


Figure 5.62 Connection of a Motor PTC

The PTC must have the following characteristics for one motor phase. The drives motor overload detection expects 3 of these PTCs to be connected in series.

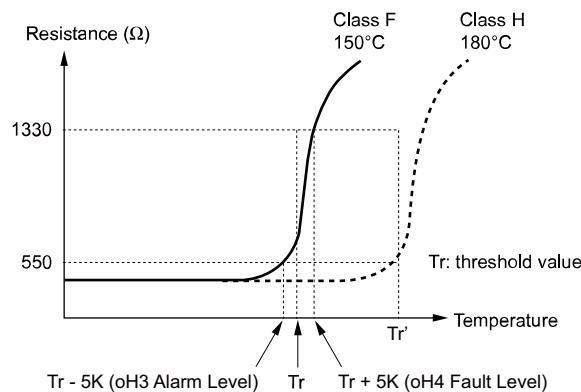


Figure 5.63 Motor PTC Characteristics

Overheat detection using a PTC can be set up by parameters L1-03, L1-04, and L1-05 as explained below.

## 5.8 L: Protection Functions

### ■ L1-03: Motor Overheat Alarm Operation Selection (PTC input)

Sets the drive operation when the PTC input signal reaches the motor overheat alarm level (oH3).

No.	Name	Setting Range	Default
L1-03	Motor Overheat Alarm Operation Selection (PTC input)	0 to 3	3

#### Setting 0: Ramp to stop

The drive stops the motor using the deceleration time 1 set in parameter C1-02.

#### Setting 1: Coast to stop

The drive output is switched off and the motor coasts to stop.

#### Setting 2: Fast Stop

The drive stops the motor using the Fast Stop time set in parameter C1-09.

#### Setting 3: Alarm only

The operation is continued and an oH3 alarm is displayed on the digital operator.

### ■ L1-04: Motor Overheat Fault Operation Selection (PTC input)

Sets the drive operation when the PTC input signal reaches the motor overheat fault level (oH4).

No.	Name	Setting Range	Default
L1-04	Motor Overheat Fault Operation Selection (PTC input)	0 to 2	1

#### Setting 0: Ramp to stop

The drive stops the motor using the deceleration time 1 set in parameter C1-02.

#### Setting 1: Coast to Stop

The drive output is switched off and the motor coasts to stop.

#### Setting 2: Fast Stop

The drive stops the motor using the Fast Stop time set in parameter C1-09.

### ■ L1-05: Motor Temperature Input Filter Time (PTC input)

Used to set a filter on the PTC input signal in order to prevent a motor overheat fault from being mistakenly detected.

No.	Name	Setting Range	Default
L1-05	Motor Temperature Input Filter Time (PTC input)	0.00 to 10.00 s	0.20 s

### ■ L1-13: Continuous Electrothermal Operation Selection

Determines whether or not to hold the current value of the electrothermal motor protection (L1-01) when the power supply is interrupted.

No.	Name	Setting Range	Default
L1-13	Continuous Electrothermal Operation Selection	0 or 1	1

#### Setting 0: Disabled

#### Setting 1: Enabled

### ■ Motor Protection Using an NTC Thermistor Input

Motor protection is possible for models CIMR-E□4A0930 and 4A1200 by connecting the NTC thermistor input in the motor windings to one of the drive analog input terminals.

This enables the drive to provide torque compensation in response to changes in motor temperature and protect the motor from overheating.

If the NTC input signal using the drive multi-function analog input terminal exceeds the overheat alarm level set to L1-16, then oH5 will flash on the digital operator screen. The drive will respond to the alarm according to the setting of L1-20 (default setting is to continue operation when an oH5 alarm occurs).

Figure 5.64 shows a circuit using the NTC thermistor and the terminal resistance values. Set DIP switch S1 on the drive to "V" for voltage input when wiring the NTC thermistor input to terminal A2 on the drive.

**Note:** This example assumes that H3-10 = 17, H3-09 = 10, and DIP switch S1 has been set for voltage input.

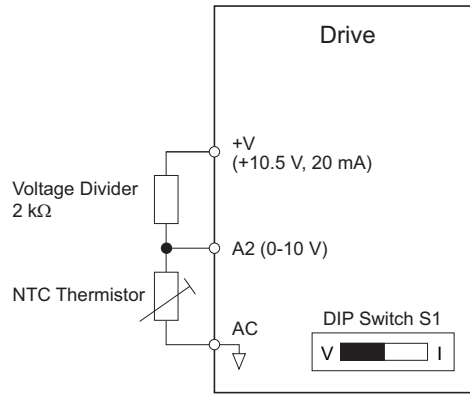


Figure 5.64 Motor Protection Circuit using NTC Input

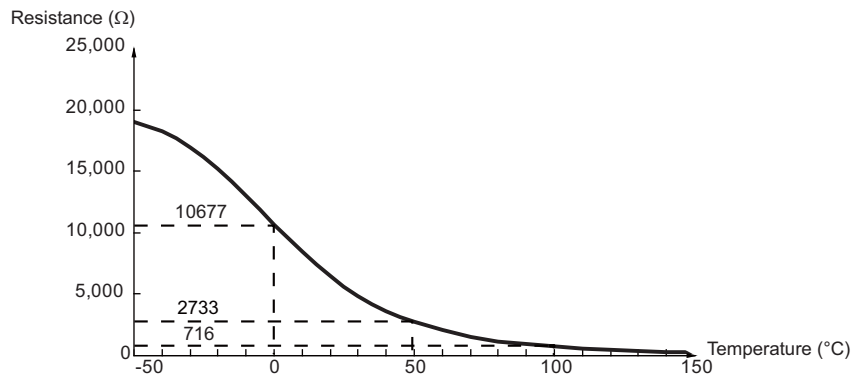


Figure 5.65 Temperature and Resistance of NTC Thermistor

L1-15 to L1-20 can determine the overheat protection settings using the NTC thermistor input. Parameter descriptions are listed below.

**Note:** L1-15 to L1-20 are available in models CIMR-E□4A0930 and 4A1200.

■ **L1-15: Motor 1 Thermistor Selection (NTC)**

**Note:** This parameter is available in models CIMR-E□4A0930 and 4A1200.

No.	Name	Setting Range	Default
L1-15	Motor 1 Thermistor Selection (NTC)	0, 1	0

Setting 0: Disable

Setting 1: Enable

■ **L1-16: Motor 1 Overheat Temperature**

Sets the temperature that will trigger an overheat fault (oH5) for motor 1.

**Note:** This parameter is available in models CIMR-E□4A0930 and 4A1200.

No.	Name	Setting Range	Default
L1-16	Motor 1 Overheat Temperature	50 to 200°C	120

Parameter Details

5

## 5.8 L: Protection Functions

### ■ L1-19: Operation at Thermistor Disconnect (THo) (NTC)

Determines drive operation when a thermistor disconnect fault occurs (THo).

**Note:** This parameter is available in models CIMR-E□4A0930 and 4A1200.

No.	Name	Setting Range	Default
L1-19	Operation at Thermistor Disconnect (THo) (NTC)	0 to 3	3

#### Setting 0: Ramp to stop

The drive stops the motor using the deceleration time1 set in parameter C1-02.

#### Setting 1: Coast to stop

The drive output is switched off and the motor coasts to stop.

#### Setting 2: Fast stop

The drive stops the motor using the Fast stop time set in parameter C1-09.

#### Setting 3: Alarm only

The operation is continued and a THo alarm is displayed on the digital operator.

### ■ L1-20: Operation at Motor Overheat (oH5)

Determines drive operation when a motor overheat fault occurs (oH5).

**Note:** This parameter is available in models CIMR-E□4A0930 and 4A1200.

No.	Name	Setting Range	Default
L1-20	Operation at Motor Overheat (oH5)	0 to 3	1

#### Setting 0: Ramp to stop

The drive stops the motor using the deceleration time1 set in parameter C1-02.

#### Setting 1: Coast to stop

The drive output is switched off and the motor coasts to stop.

#### Setting 2: Fast stop

The drive stops the motor using the Fast stop time set in parameter C1-09.

#### Setting 3: Alarm only

The operation is continued and an oH5 alarm is displayed on the digital operator.

## ◆ L2: Momentary Power Loss Ride-Thru

### ■ L2-01: Momentary Power Loss Operation Selection

When a momentary power loss occurs (DC bus voltage falls below the level set in L2-05), the drive can be set to automatically return to the operation it was performing when the power went out based on certain conditions.

No.	Name	Setting Range	Default
L2-01	Momentary Power Loss Operation Selection	0 to 5	0

#### Setting 0: Disabled (default)

If power is not restored within 15 ms, a Uv1 fault will result and the drive will stop the motor. The motor coasts to stop.

#### Setting 1: Recover within L2-02

When a momentary power loss occurs, the drive output will be shut off. Should the power return within the time set to parameter L2-02, the drive will perform Speed Search and attempt to resume operation. If power is not restored within this time (i.e., DC bus voltage level remains below Uv1 detection level L2-05), then a Uv1 fault is triggered.

**Setting 2: Recover as long as CPU has power**

When a momentary power loss occurs, the drive output will be shut off. Should the power return as long as the drive control circuit has power, the drive will attempt to perform Speed Search and resume the operation. A Uv1 fault is not triggered.

**Setting 3: KEB Ride-Thru operation within L2-02**

The drive decelerates using regenerative energy from the motor until the time set in L2-02 has expired. It then tries to accelerate back to the frequency reference. If the power does not returned within the time set in L2-02, an Uv1 fault is triggered and the drive output shuts off. The type of KEB operation is determined by the setting of L2-29.

**Setting 4: KEB Ride-Thru as long as CPU has power**

The drive decelerates using regenerative energy from the motor until the power returns and then restarts. If the motor has come to a stop before, the power returns. If the drive control power gets lost, the drive output will shut off. A Uv1 fault is not triggered. The type of KEB operation is determined by the setting of L2-29.

**Setting 5: Ramp to stop with KEB deceleration**

The drive ramps to stop using the regenerative energy from the motor. Even if the power is restored, the drive will continue decelerating until it brings the motor to a complete stop. The type of KEB operation is determined by the setting of parameter L2-29. Note that if an input terminal set for KEB 1 (H1-□□ = 65, 66) is triggered while the drive is decelerating, then it will accelerate back up to speed when the input is released.

**Notes on Settings 1 through 5**

- “Uv” will flash on the operator while the drive is attempting to recover from a momentary power loss. A fault signal is not output at this time.
- A Momentary Power Loss Unit is available to allow for a longer momentary power loss ride through time in the drive model CIMR-E□2A0004 through 2A0056 and CIMR-E□4A0002 through 4A0031. This option makes it possible to continue running after up to two seconds of power loss.
- When a magnetic contactor between motor and drive is used, be sure that the magnetic contactor remains closed as long as the drive performs KEB operation or attempts to restart with Speed Search.
- Make sure the Run command is kept active during KEB operation. Otherwise the drive cannot accelerate back to the frequency reference when the power returns.
- When L2-01 is set to 3, 4, or 5, KEB Ride-Thru will be executed as specified in L2-29.

**■ KEB Ride-Thru Function**

When power loss is detected, the Kinetic Energy Backup Ride-Thru function (KEB Ride-Thru) decelerates the motor and uses regenerative energy to keep the main circuit operating. Despite power loss, the drive output is not interrupted.

No.	Name	Setting Range	Default
L2-29	KEB Ride-Thru Function	0, 1	0

**Single Drive KEB Ride-Thru 1 (L2-29 = 0)**

Once KEB Ride-Thru begins, the drive uses regenerative energy from the motor to keep the DC bus voltage at the level set to L2-11 while adjusting the rate of deceleration based on the time set to L2-06.

**Note:** If undervoltage occurs in the DC bus (Uv1), shorten the KEB deceleration time (L2-06). If overvoltage occurs (oV), increase the KEB deceleration time.

**Single Drive KEB Ride-Thru 2 (L2-29 = 1)**

The drive uses information about the inertia of the connected machinery to determine the deceleration rate necessary to keep the DC bus voltage at the level set in parameter L2-11. The resulting deceleration time is calculated based on the system inertia and cannot be adjusted.

■ KEB Ride-Thru Start

KEB operation is always triggered in the same way, independent of the selected KEB operation mode. When the KEB function is selected as the function to be executed when power loss operation occurs (L2-01 = 3, 4, or 5), then KEB Ride-Thru will be activated if one of the following conditions becomes true:

- A digital input programmed for H1-□□ = 65 or 66 is activated. This will start KEB operation using the mode selected in parameter L2-29.
- A digital input programmed for H1-□□ = 7A or 7B is activated. This will automatically select Single KEB Ride-Thru 2, disregarding the setting of L2-29.
- The DC bus voltage fell below the level specified in L2-05. The KEB operation will start as specified in L2-29.

**Note:** KEB Ride-Thru 1 and 2 cannot both be assigned to input terminals at the same time. Attempting this will trigger an oPE3 error.

If a digital input is used for triggering the KEB operation and the device that controls the input acts relatively slow, parameter L2-10 can be used to set a minimum KEB operation time. In the example below, KEB operation is triggered by the DC bus voltage and the Hold command is triggered by a digital input.

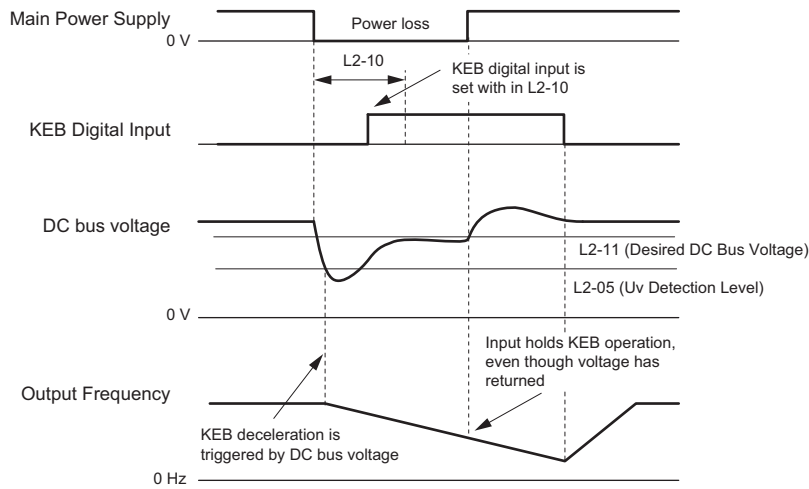


Figure 5.66 KEB Operation Using a KEB Input

■ KEB Ride-Thru End Detection

The KEB function end detection depends on the setting of parameter L2-01 and if a digital input programmed for KEB (H1-□□ = 65, 66, 7A, 7B) is used or not.

KEB Ride-Thru Operation in L2-02, Input Terminals Not Used

Here, L2-01 = 3 and the input terminals have not been set for KEB Ride-Thru (H1-□□ does not equal 65, 66, 7A, 7B). After decelerating for the time set in parameter L2-02, the drive ends KEB operation and attempts to accelerate back to the frequency reference. If the power has not returned within L2-02, an Uv1 fault occurs and the drive output shuts off.

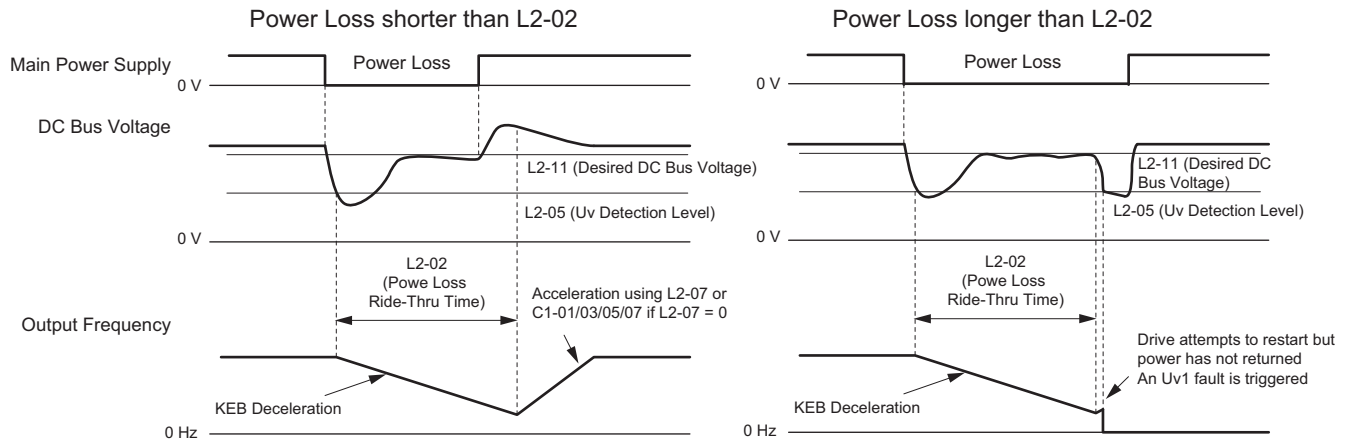


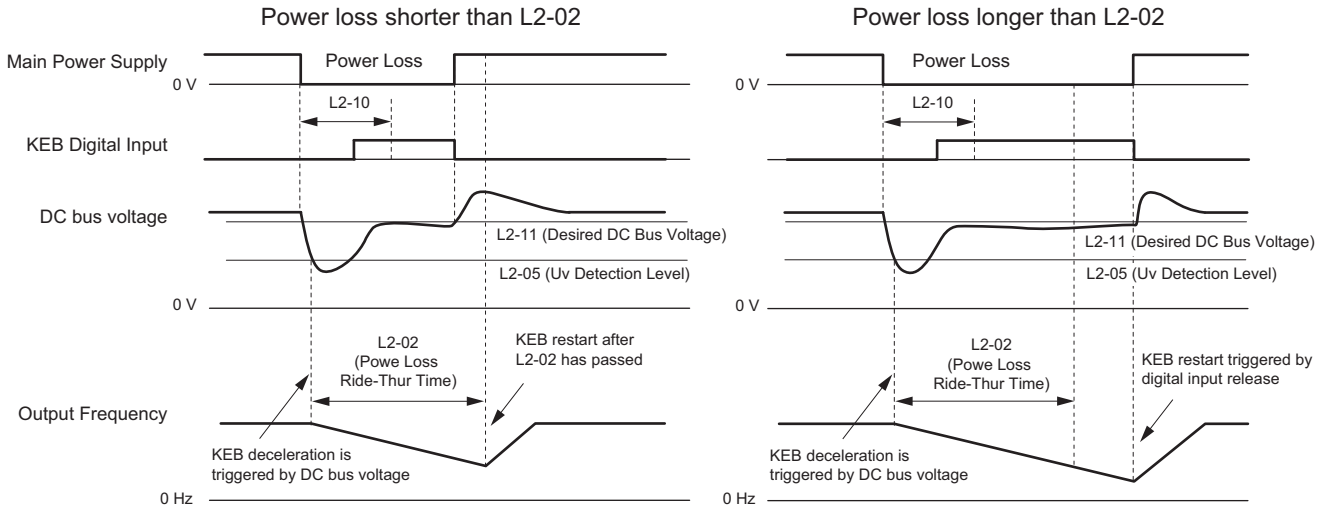
Figure 5.67 KEB Operation Using L2-02, Without KEB Input



**KEB Ride-Thru Operation Within L2-02, Input Terminals Used**

Here, L2-01 = 3 and an input terminal is set to issue KEB Ride-Thru (H1-□□ = 65, 66, 7A, 7B). After decelerating for the time set in parameter L2-02, the drive checks the DC bus voltage and the status of the digital input. If the DC bus voltage is still below the level set in L2-11 or if the KEB digital input is still active, KEB deceleration continues. If the voltage level has risen above the value set to L2-11, then normal operation is resumed.

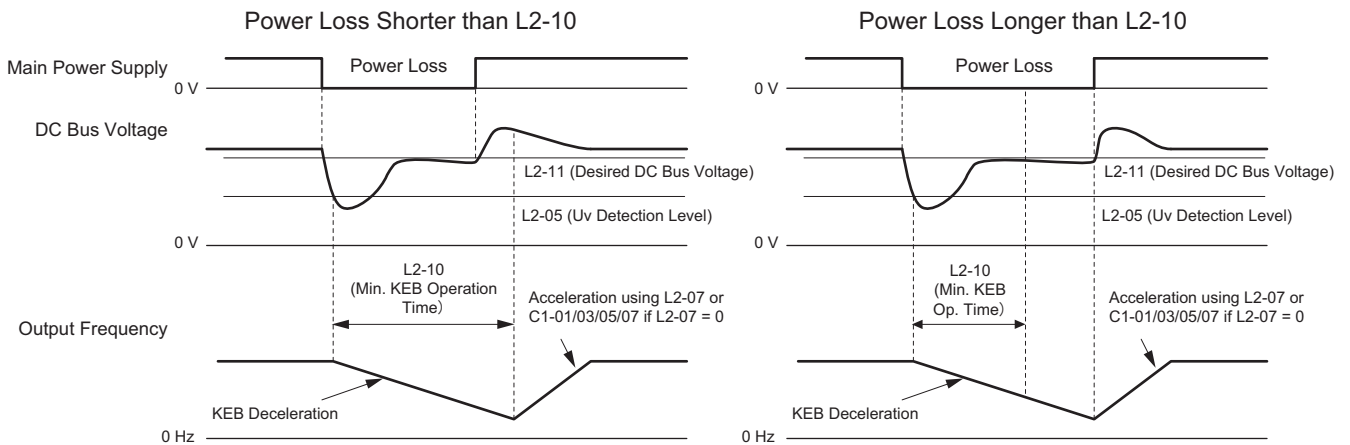
**Note:** The time set in L2-02 has priority over L2-10. Even if L2-10 is set to a longer time than L2-02, once the time in L2-02 passes, the drive will check the DC bus voltage level and the status of the terminal assigned to KEB Ride-Thru, then try to restart.



**Figure 5.68 KEB Operation Using L2-02 and KEB Input**

**KEB Ride-Thru Operation as Long as CPU Has Power, KEB Input Not Used**

Here, L2-01 = 4 and the input terminals have not been set for KEB Ride-Thru (H1-□□ does not equal 65, 66, 7A, 7B). After decelerating for the time set in parameter L2-10, the drive checks the DC bus voltage level. If the DC bus voltage is lower than the level set in L2-11, then deceleration continues. Once the DC bus voltage rises above the value of L2-11, normal operation is resumed.



**Figure 5.69 KEB Operation Using L2-10, Without KEB Input**

Parameter Details

5

## 5.8 L: Protection Functions

### KEB Ride-Thru Operation as Long as CPU Has Power, KEB Input Used

Here, L2-01 = 3 and an input terminal is set to issue KEB Ride-Thru (H1-□□ = 65, 66, 7A, 7B). After decelerating for the time set in parameter L2-10, the drive checks the DC bus voltage and the status of the digital input. If the DC bus voltage is still below the level set in L2-11 or if the digital input assigned to KEB Ride-Thru is still active, then the drive continues to decelerate. If the DC bus voltage has risen above L2-11 and the terminal that initiated KEB Ride-Thru is released, then operation resumes.

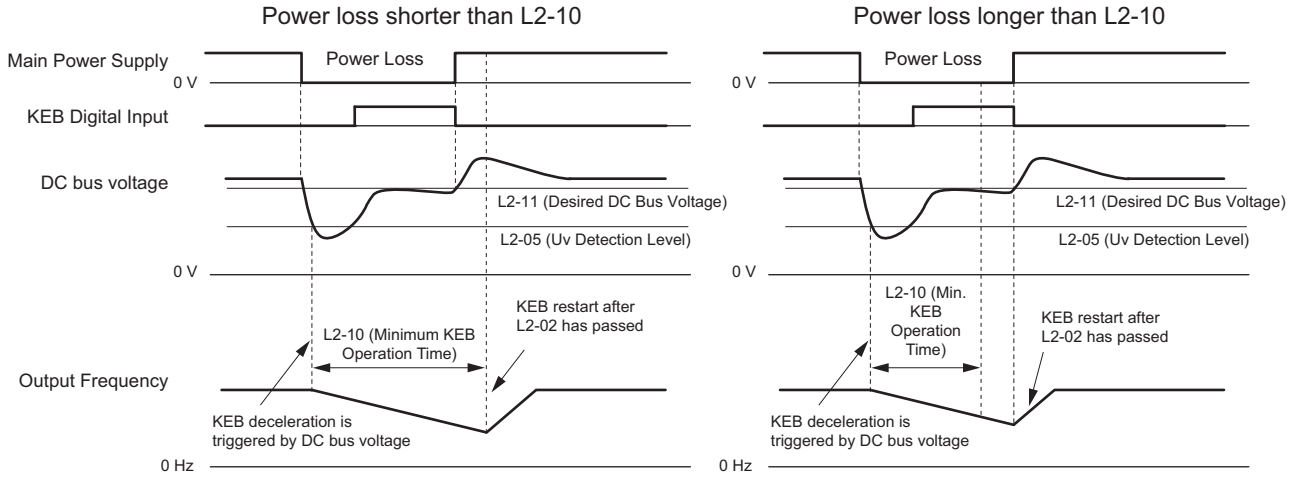


Figure 5.70 KEB Operation Using L2-10 and KEB Input

### L2-01 = 5

KEB operation ends when the motor has come to a stop, even if the power returns and the digital input terminal that initiated KEB Ride-Thru is cleared.

### KEB Operation Wiring Example

Figure 5.71 shows a wiring example for triggering the KEB Ride-Thru at power loss using an undervoltage relay. If power loss occurs, the undervoltage relay triggers KEB Ride-Thru at terminal S6 (H1-06 = 65, 66, 7A, 7B).

**Note:** Make sure the Run command is not switched off during momentary power loss. If the Run command is shut off, the drive will not accelerate back to speed when the power is restored.

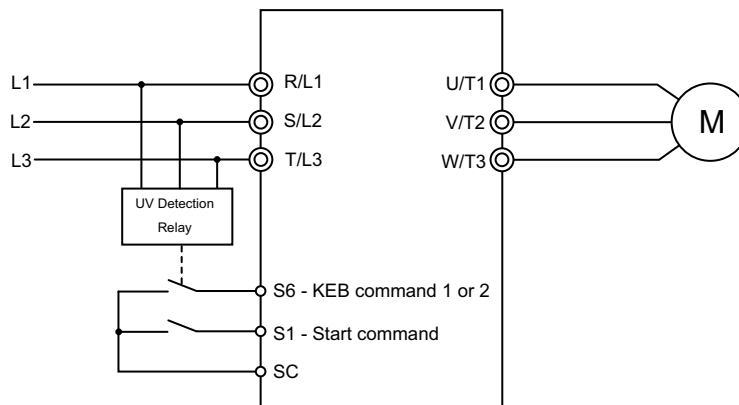


Figure 5.71 KEB Function Wiring Example

### Parameters for KEB Ride-Thru

Table 5.31 lists parameters needed to set up KEB Ride-Thru depending the type of KEB Ride-Thru selected in L2-29.

Table 5.31 KEB Function Related Adjustments

Parameter	Name	Setting Instructions	KEB Mode (L2-29)	
			0	1
C1-09	Fast Stop Time	<ul style="list-style-type: none"> <li>Increase if an overvoltage fault (ov) occur during KEB deceleration.</li> <li>Decrease if an undervoltage fault (Uv1) occurs during KEB deceleration.</li> </ul>	YES	NO
L2-05	Undervoltage Detection Level	Increase if an undervoltage fault (Uv1) fault occurs at KEB operation start in order to let the drive detect power loss more quickly.	YES	YES

Parameter	Name	Setting Instructions	KEB Mode (L2-29)	
			0	1
L2-06	KEB Deceleration Time	<ul style="list-style-type: none"> <li>Increase if an overvoltage fault (ov) occur during KEB deceleration</li> <li>Decrease if an undervoltage fault (Uv1) occurs during KEB deceleration</li> </ul>	NO	NO
L2-07	KEB Acceleration Time	Adjust to the desired acceleration time. If set to 0, standard acceleration times are used (C1-01, C1-03).	YES	YES
L2-08	Frequency Gain at KEB Start	<ul style="list-style-type: none"> <li>Increase if an undervoltage fault occurs right after KEB operation starts.</li> <li>Decrease if an overvoltage fault occurs right after KEB operation starts.</li> </ul>	YES	NO
L2-10	KEB Detection Time	<ul style="list-style-type: none"> <li>Increase when a digital input is set for KEB Ride-Thru and an undervoltage fault occurs after power was lost because the device that controls the input does not react quickly enough.</li> <li>If the DC bus voltage overshoots after KEB Ride-Thru begins (and no input terminal is set to KEB Ride-Thru), increase L2-10 to longer than the overshoot.</li> </ul>	YES	YES
L2-11	Desired DC Bus Voltage during KEB	<ul style="list-style-type: none"> <li>Set to around 1.22 times the input voltage for Single Drive KEB Ride-Thru 2.</li> <li>Set to around 1.4 times the input voltage for Single Drive KEB Ride-Thru 1.</li> </ul>	YES	YES
L3-20	Main Circuit Adjustment Gain	<ul style="list-style-type: none"> <li>Increase this setting slowly in steps of 0.1 if overvoltage (ov) or undervoltage (Uv1) occurs at the beginning of deceleration</li> <li>Reduce if torque ripple occurs during deceleration while executing KEB Ride-Thru.</li> </ul>	NO	YES
L3-21	Accel/Decel Rate Calculation Gain	<ul style="list-style-type: none"> <li>Reduce L3-21 in steps of 0.05 if there is a fairly large speed or current ripple.</li> <li>Decreasing this setting too much can result in a slow DC bus voltage control response, and may lead to problems with overvoltage or undervoltage.</li> </ul>	NO	YES
L3-24	Motor Acceleration Time	Set the motor acceleration time as described on page 226.	NO	YES
L3-25	Load Inertia Ratio	Set the load/inertia ratio as described on page 226.	NO	YES

### ■ L2-02: Momentary Power Loss Ride-Thru Time

Sets the maximum time allowed to ride through a power loss. If power loss operation exceeds this time, the drive will attempt to accelerate back to frequency reference. This parameter is valid if L2-01 = 1 or 3.

**Note:** The amount of time the drive is capable of recovering after a power loss is determined by the capacity of the drive. Drive capacity determines the upper limit for L2-02.

No.	Name	Setting Range	Default
L2-02	Momentary Power Loss Ride-Thru Time	0.0 to 25.5 s	Determined by o2-04

### ■ L2-03: Momentary Power Loss Minimum Baseblock Time

Sets the minimum baseblock time when power is restored following a momentary power loss. This determines the time the drive waits for the residual voltage in the motor to dissipate. Increase this setting if overcurrent or overvoltage occurs at the beginning of Speed Search, after a power loss, or during DC Injection Braking.

No.	Name	Setting Range	Default
L2-03	Momentary Power Loss Minimum Baseblock Time	0.1 to 5.0 s	Determined by o2-04

### ■ L2-04: Momentary Power Loss Voltage Recovery Ramp Time

Sets the time for the drive to restore the output voltage to the level specified by the V/f pattern after Speed Search. The setting value determines the time for the voltage to go from 0 V to the maximum voltage.

No.	Name	Setting Range	Default
L2-04	Momentary Power Loss Voltage Recovery Ramp Time	0.0 to 5.0 s	Determined by o2-04

### ■ L2-05: Undervoltage Detection Level (Uv)

Determines the voltage at which a Uv1 fault is triggered or at which the KEB function is activated. This setting rarely needs to be changed.

No.	Name	Setting Range	Default
L2-05 <1>	Undervoltage Detection Level	150 to 210 Vdc	Determined by A1-02, E1-01 and o2-04 <2>

<1> Values are for 200 V class drives and must be doubled for 400 V class drives.

<2> The default setting for 400 V class drives will vary depending on if the drive input voltage is over or under 400 V.

- Note:**
- When setting L2-05 below the default value, an AC reactor option should be installed to the input side of the power supply to prevent damage to drive circuitry.
  - If using KEB Ride-Thru and L2-05 is set too low, then undervoltage in the DC bus (uv1) will be triggered before KEB Ride-Thru can be executed. Take caution not to set this value too low.

## 5.8 L: Protection Functions

### ■ L2-06: KEB Deceleration Time

Sets the time to decelerate from the frequency reference at the time KEB Ride-Thru was initiated down to zero speed.

No.	Name	Setting Range	Default
L2-06	KEB Deceleration Time	0.00 to 6000.0 s </>	0.00 s

<1> Setting range is determined by the accel/decel time units set in C1-10. If the time is set in units of 0.01 s (C1-10 = 0), the setting range becomes 0.00 to 600.00 s.

### ■ L2-07: KEB Acceleration Time

Sets the time to reaccelerate from the speed when KEB was deactivated to the frequency reference.

When set to 0.0 s, the drive will accelerate back up to speed according to the active deceleration time set by C1-01, C1-03.

No.	Name	Setting Range	Default
L2-07	KEB Acceleration Time	0.00 to 6000.0 s	0.00 s

### ■ L2-08: Frequency Gain at KEB Start

When the KEB Ride-Thru command is input, the output frequency is reduced in a single step in order to quickly get the motor into a regenerative state. The amount of this frequency reduction can be calculated using the formula below. Note that L2-08 can only be used with induction motors.

Amount of reduction = Slip frequency prior to KEB  $\times$  (L2-08)  $\times$  2

No.	Name	Setting Range	Default
L2-08	Frequency Gain at KEB Start	0 to 300%	100%

### ■ L2-10: KEB Detection Time (Minimum KEB Time)

Parameter L2-10 determines how long KEB Ride-Thru must operate once it is triggered. Also refer to [KEB Ride-Thru End Detection on page 216](#).

No.	Name	Setting Range	Default
L2-10	KEB Detection Time	0 to 2000 ms	50 ms

### ■ L2-11: DC Bus Voltage Setpoint during KEB

Determines the setpoint (target value) for the DC bus voltage during Single KEB Ride-Thru 2. For Single KEB Ride-Thru 1, parameter L2-11 defines the voltage level to end KEB Ride-Thru.

No.	Name	Setting Range	Default
L2-11	DC Bus Voltage Setpoint during KEB	150 to 400 Vdc </>	<2>

<1> Values are for 200 V class drives and must be doubled for 400 V class drives.

<2> Default setting is determined by E1-01.

### ■ L2-29: KEB Method Selection

Selects the way the Kinetic Energy Buffering function operates.

The KEB function is not active when L2-01 is set to 4.

**Note:** If a multi function input is set for Single KEB Ride-Thru 2 (H1-□□ = 7A, 7B) the setting of L2-29 is disregarded and the KEB mode equal to L2-29 = 1 is automatically selected.

No.	Name	Setting Range	Default
L2-29	KEB Method Selection	0, 1	0

**Setting 0: Single Drive KEB Ride-Thru 1**

**Setting 1: Single Drive KEB Ride-Thru 2**

Refer to [KEB Ride-Thru Function on page 215](#) for detailed explanations.

## ◆ L3: Stall Prevention

When the load is too high or acceleration and deceleration times are too short, the motor may be unable to keep up with the frequency reference, resulting in excessive slip. During acceleration, this usually causes an overcurrent fault (oC), drive overload (oL2), or motor overload (oL1). During deceleration, it can cause excessive regenerative power to flow back into the DC bus capacitors, eventually causing the drive to fault out from overvoltage (oV). The drive can prevent the motor from stalling and still reach the desired speed without the user needing to change the acceleration or deceleration time settings. The Stall Prevention function can be set separately for acceleration, operating at constant speeds, and deceleration.

### ■ L3-01: Stall Prevention Selection during Acceleration

Stall Prevention during acceleration (L3-01) prevents tripping with overcurrent (oC), motor overload (oL1), or drive overload (oL2) faults common when accelerating with heavy loads.

L3-01 determines the type of Stall Prevention the drive should use during acceleration.

No.	Name	Setting Range	Default
L3-01	Stall Prevention Selection during Acceleration	0 to 2	1

#### Setting 0: Disabled

No Stall Prevention is provided. If the acceleration time is too short, the drive may not be able to get the motor up to speed fast enough, thus tripping an overload fault.

#### Setting 1: Enabled

Enables Stall Prevention during acceleration. Operation varies, depending on the control mode.

- V/f Control:

If the output current rises above the Stall Prevention level set in L3-02, then the drive stops accelerating. Acceleration will not resume until the output current falls 15% below the setting in L3-02.

The Stall Prevention level is automatically reduced in the constant power range. *Refer to L3-03: Stall Prevention Limit during Acceleration on page 222.*

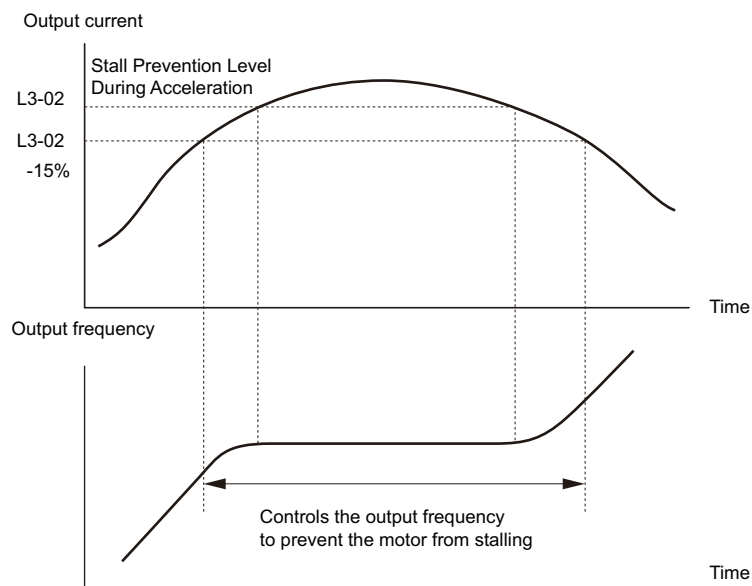


Figure 5.72 Stall Prevention During Acceleration for Induction Motors

## 5.8 L: Protection Functions

- Open Loop Vector Control for PM:

If the output current remains above the Stall Prevention level set in L3-02 for the time set in L3-27, then the drive will begin to decelerate using the deceleration time set in L3-22. (*Refer to L3-22: Deceleration Time at Stall Prevention during Acceleration on page 223.*) Acceleration will not resume until the output current falls 15% below the setting in L3-02.

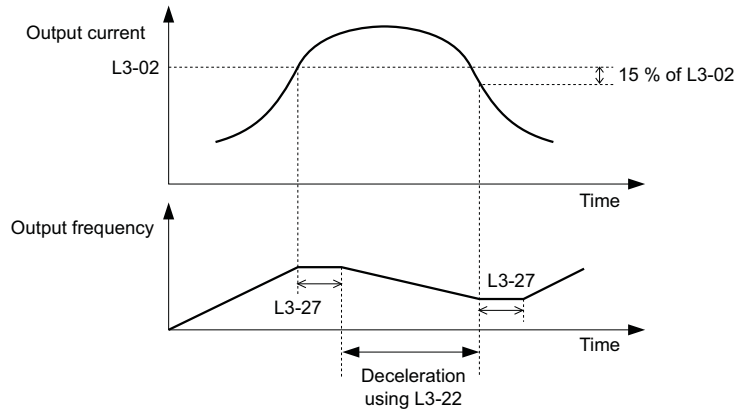


Figure 5.73 Stall Prevention During Acceleration for Permanent Magnet Motors

### Setting 2: Intelligent Stall Prevention

When L3-02 = 2, the drive will disregard the selected acceleration time and try to accelerate in the minimum time. The acceleration rate is adjusted so that the current does not exceed the value set in parameter L3-02.

#### ■ L3-02: Stall Prevention Level during Acceleration

Sets the output current level at which the Stall Prevention during acceleration is activated.

No.	Name	Setting Range	Default
L3-02	Stall Prevention Level during Acceleration	0 to 150% </>	</>

<1> The upper limit and default value is determined by the carrier frequency derating selection (L8-38).

- Stalling may occur when the motor is rated at a smaller capacity than the drive and the Stall Prevention default settings are used. Set L3-02 as appropriate if stalling occurs.
- When operating the motor in the constant power range, also set parameter L3-03.

#### ■ L3-03: Stall Prevention Limit during Acceleration

The Stall Prevention level is automatically reduced when the motor is operated in the constant power range. L3-03 sets the lower limit for this reduction as a percentage of the drive rated current.

No.	Name	Setting Range	Default
L3-03	Stall Prevention Limit during Acceleration	0 to 100%	50%

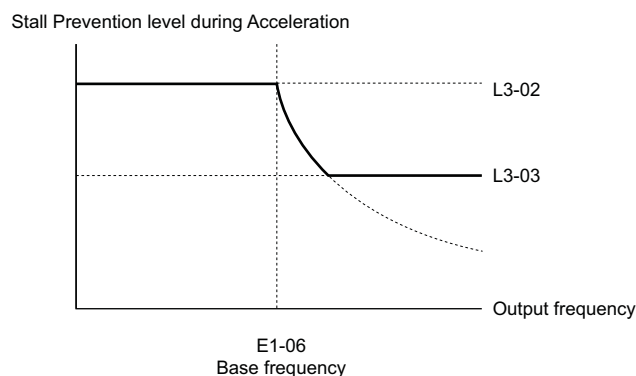


Figure 5.74 Stall Prevention Level and Limit During Acceleration

### ■ L3-22: Deceleration Time at Stall Prevention during Acceleration

Sets the brief deceleration time used when stalling occurs while accelerating a PM motor. When set to 0, this function is disabled and the drive will decelerate at the selected deceleration time when stalling occurs.

The function is effective only in Open Loop Vector Control for PM motors and if parameter L3-01 is set to 1.

No.	Name	Setting Range	Default
L3-22	Deceleration Time at Stall Prevention During Acceleration	0 to 6000.0 s	0.0 s

### ■ L3-04: Stall Prevention Selection during Deceleration

Stall Prevention during deceleration can control the deceleration based on the DC bus voltage and prevent an overvoltage fault caused by high inertia or rapid deceleration.

No.	Name	Setting Range	Default
L3-04	Stall Prevention Selection During Deceleration	0 to 2, 4, 5 <I>	1

<I> Settings 4 and 5 are not available in OLV/PM.

#### Setting 0: Disabled

When this setting is used, the drive decelerates according to the set deceleration time. With high inertia loads or rapid deceleration, an overvoltage (ov) fault may occur. In this case use braking options or switch to another L3-04 selection.

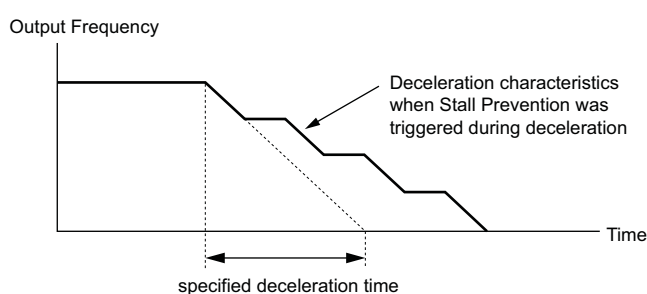
#### Setting 1: General-purpose Stall Prevention

With this setting the drive tries to decelerate within the set deceleration time. When the DC bus voltage exceeds the Stall Prevention level, the drive pauses deceleration. Deceleration continues as soon as the DC bus voltage drops below that level. Stall Prevention may be triggered repeatedly to avoid an overvoltage fault. The DC bus voltage level for Stall Prevention depends on the input voltage setting E1-01.

Drive Input Voltage	Stall Prevention Level during Deceleration
200 V Class	377 Vdc
400 V Class	754 Vdc

- Note:**
1. This setting should not be used in combination with a Dynamic Braking Resistor or other braking options. If Stall Prevention during deceleration is enabled, it will be triggered before the braking resistor option can operate.
  2. This method may lengthen the total deceleration time compared to the set value. If this is not appropriate for the application consider using a braking option.

*Figure 5.75* illustrates the function of Stall Prevention during deceleration.



**Figure 5.75 Stall Prevention During Deceleration**

#### Setting 2: Intelligent Stall Prevention

With this setting, the drive adjusts the deceleration rate so that the DC bus voltage is kept at the level set in parameter L3-17. This way the shortest possible deceleration time is achieved while the motor is protected from stalling. The deceleration time that has been selected is disregarded, but the achievable deceleration time cannot be smaller than 1/10 of the set deceleration time.

This function uses the following parameters for adjusting the deceleration rate:

- DC bus voltage gain (L3-20)
- Deceleration rate calculations gain (L3-21)
- Inertia calculations for motor acceleration time (L3-24)
- Load inertia ratio (L3-25)

## 5.8 L: Protection Functions

**Note:** As the deceleration time is not constant, Intelligent Stall Prevention should not be used in applications where stopping accuracy is a concern. Use braking options instead.

### Setting 4: Overexcitation Deceleration 1

Overexcitation Deceleration 1 (increasing the motor flux) is faster than deceleration with no Stall Prevention (L3-04 = 0). Setting 4 changes the selected decel time and functions to provide protection from an overvoltage trip. Refer to [Overexcitation Deceleration \(Induction Motors\) on page 242](#) for details.

### Setting 5: Overexcitation Deceleration 2

Overexcitation Deceleration 2 slows down the motor while trying to maintain the DC bus voltage at the level set in parameter L3-17. This function shortens the achievable deceleration time more than by using Overexcitation Deceleration 1. Setting 5 will shorten/lengthen the decel time to maintain the L3-17 bus level. Refer to [Overexcitation Deceleration \(Induction Motors\) on page 242](#) for details.

### ■ L3-05: Stall Prevention Selection during Run

Stall Prevention during run can prevent a motor from stalling by automatically reducing the speed when a transient overload occurs while the motor is running at constant speed.

This parameter determines how Stall Prevention works during run.

No.	Name	Setting Range	Default
L3-05	Stall Prevention Selection During Run	0 to 2	1

**Note:** 1. This parameter is available in V/f and OLV/PM.

2. When output frequency is 6 Hz or less, Stall Prevention during run is disabled regardless of the setting in L3-05 and L3-06.

### Setting 0: Disabled

Drive runs at the set frequency reference. A heavy load may cause the motor to stall and trip the drive with an oC or oL fault.

### Setting 1: Decelerate using C1-02

If the current exceeds the Stall Prevention level set in parameter L3-06, then the drive will decelerate at decel time 1 (C1-02). Once the current level drops below the value of L3-06 minus 2% for 100 ms, the drive accelerates back to the frequency reference at the active acceleration time.

### Setting 2: Decelerate using C1-04

Same as setting 1 except the drive decelerates at decel time 2 (C1-04).

### ■ L3-06: Stall Prevention Level during Run

Sets the current level to trigger Stall Prevention during run. Depending on the setting of parameter L3-23, the level is automatically reduced in the constant power range (speed beyond base speed).

The Stall Prevention level can be adjusted using an analog input. Refer to [Multi-Function Analog Input Terminal Settings on page 202](#) for details.

No.	Name	Setting Range	Default
L3-06	Stall Prevention Level During Run	30 to 150 <I>	<I>

<I> The upper limit and default for this setting is determined by L8-38.

### ■ L3-23: Automatic Reduction Selection for Stall Prevention during Run

This function reduces the Stall Prevention during run level in the constant power range.

No.	Name	Setting Range	Default
L3-23	Automatic Reduction Selection for Stall Prevention During Run	0 or 1	0

### Setting 0: Disabled

The level set in L3-06 is used throughout the entire speed range.

### Setting 1: Enabled

The Stall Prevention level during run is reduced in the constant power range. The lower limit will be 40% of L3-06.



## ■ Overvoltage Suppression Function

This function suppresses overvoltage faults by decreasing the regenerative torque limit and slightly increasing the output frequency when the DC bus voltage rises. It can be used to drive loads with cyclic regenerative operation, such as a punch press or other applications that involve repetitive crank movements.

The regenerative torque limit and the output frequency are adjusted during ov suppression so that the DC bus voltage does not exceed the level set in parameter L3-17. In addition to the parameters explained below, ov suppression also uses these settings for frequency adjustment:

- DC bus voltage gain (L3-20)
- Deceleration rate calculations gain (L3-21)
- Inertia calculations for motor acceleration time (L3-24)
- Load inertia ratio (L3-25)

- Note:**
1. The motor speed will exceed the frequency reference when overvoltage suppression is triggered. Consequently, overvoltage suppression is not appropriate in applications that require a perfect match between the frequency reference and the motor speed.
  2. Disable overvoltage suppression when using a braking resistor.
  3. Overvoltage may still occur if there is a sudden increase to a regenerative load.
  4. This function is enabled only when operating just below the maximum frequency. Overvoltage suppression does not increase the output frequency beyond the maximum frequency. If this is required by the application, increase the maximum frequency and change the base frequency setting.

## ■ L3-11: Overvoltage Suppression Function Selection

Enables or disables the overvoltage suppression function.

No.	Name	Setting Range	Default
L3-11	Overvoltage Suppression Function Selection	0 or 1	0

### Setting 0: Disabled

The regenerative torque limit and the output frequency are not adjusted. A regenerative load may trip the drive with an overvoltage fault. Use this setting if braking options are installed.

### Setting 1: Enabled

When the DC bus voltage rises due to regenerative load, an overvoltage fault is prevented by decreasing the regenerative torque limit and increasing the output frequency.

## ■ L3-17: Target DC Bus Voltage for Overvoltage Suppression and Stall Prevention

Sets the target DC bus voltage target level used by the overvoltage suppression function (L3-11 = 1), Intelligent Stall Prevention during deceleration (L3-04 = 2).

No.	Name	Setting Range	Default
L3-17	Target DC Bus Voltage for Overvoltage Suppression and Stall Prevention	150 to 400 Vdc <1>	370 Vdc <1> <2>

<1> Values are for 200 V class drives and must be doubled for 400 V class drives.

<2> This value is initialized when E1-01 is changed.

## ■ L3-20: DC Bus Voltage Adjustment Gain

Determines the proportional gain used by overvoltage suppression (L3-11 = 1), Single Drive KEB 2 (L2-29 = 1), KEB Ride Thru 2 (H1-□□ = 7A or 7B) and Intelligent Stall Prevention during deceleration (L3-04 = 2) in order to control the DC bus voltage.

No.	Name	Setting Range	Default
L3-20	DC Bus Voltage Adjustment Gain	0.00 to 5.00	Determined by A1-02

### Adjustment for Single Drive KEB 2 (L2-29 = 1) and Intelligent Stall Prevention During Deceleration

- Increase this setting slowly in steps of 0.1 if overvoltage or undervoltage occurs at the beginning of deceleration.
- If this setting is too high, then a fair amount of speed or torque ripple can result.

### Adjustment for Overvoltage Suppression

- Increase this setting slowly in steps of 0.1 if overvoltage suppression is enabled (L3-11 = 1) and a sudden increase in a regenerative load results in an overvoltage (ov) fault.
- If this setting is too high, excessive speed or torque ripple can result.

## 5.8 L: Protection Functions

### ■ L3-21: Accel/Decel Rate Calculation Gain

Determines the proportional gain used by overvoltage suppression (L3-11 = 1), Single Drive KEB 2 (L2-29 = 1), and Intelligent Stall Prevention during deceleration (L3-04 = 2) in order to calculate acceleration and deceleration rates.

No.	Name	Setting Range	Default
L3-21	Accel/Decel Rate Calculation Gain	0.10 to 10.00	<J>

<J> This value is reset to its default value when the control mode is changed (A1-02).

#### Adjustment for Single Drive KEB 2 (L2-29 = 1) and Intelligent Stall Prevention During Deceleration

- Reduce L3-21 in steps of 0.05 if there is a fairly large speed or current ripple.
- Small reductions of L3-21 can also help solve problems with overvoltage and overcurrent.
- Decreasing this setting too much can result in a slow DC bus voltage control response and may also lengthen deceleration times beyond optimal levels.

#### Adjustment for Overvoltage Suppression

- Increase this setting in steps of 0.1 if overvoltage occurs as a result of a regenerative load when overvoltage suppression is enabled (L3-11 = 1).
- If there is a fairly large speed ripple when overvoltage suppression is enabled, then decrease L3-21 in steps of 0.05.

### ■ L3-24: Motor Acceleration Time for Inertia Calculations

Sets the time it takes to accelerate the motor from stop to the maximum speed at motor rated torque. This parameter should be set when using Single Drive KEB 2 (L2-29 = 1), Intelligent Stall Prevention during deceleration (L2-04 = 2), or the overvoltage suppression function (L3-11 = 1).

No.	Name	Setting Range	Default
L3-24	Motor Acceleration Time for Inertia Calculations	0.001 to 10.000 s	Determined by o2-04, E2-11, and E5-01 <J>

<J> Parameter L3-24 is defaulted for a Yaskawa standard 4-pole motor. During Auto-Tuning, L3-24 will be initialized to a Yaskawa standard 4-pole motor if parameter E2-11 is changed. This value also changes based on the motor code set to E5-01 when using the Open Loop Vector Control Mode for PM motors.

#### Automatic Parameter Setup

In Closed Loop Vector Control for induction motors or PM motors, the Inertia Auto-Tuning function can be used to let the drive automatically adjust this parameter. [Refer to Auto-Tuning on page 113.](#)

#### Manual Parameter Setup

Calculations are made as follows:

$$L3-24 = \frac{2 \cdot \pi \cdot J [kgm^2] \cdot n_{rated} [r/min]}{60 \cdot T_{rated} [Nm]}$$

The rated torque can be calculated as follows:

$$T_{rated} [Nm] = \frac{60 \cdot P_{Motor} [kW] \cdot 10^3}{2 \cdot \pi \cdot n_{rated} [r/min]}$$

### ■ L3-25: Load Inertia Ratio

Determines the ratio between the rotor inertia and the load. Set this parameter when using Single Drive KEB 2 (L2-29 = 1), Intelligent Stall Prevention during deceleration (L3-04 = 2), or the overvoltage suppression function (L3-11 = 1).

No.	Name	Setting Range	Default
L3-25	Load Inertia Ratio	1.0 to 1000.0	1.0

When set incorrectly, a fairly large current ripple can result during Single Drive KEB 2 (L2-29 = 1) and overvoltage suppression (L3-11 = 1) or other faults such as ov, Uv1, and oC may occur.

#### Automatic Parameter Setup

In Closed Loop Vector Control for induction motors or PM motors the Inertia Auto-Tuning function can be used to let the drive automatically adjust this parameter. [Refer to Auto-Tuning on page 113.](#)

## Manual Parameter Setup

Parameter L3-25 can be calculated by:

$$L3-25 = \frac{\text{Machine Inertia}}{\text{Motor Inertia}}$$

### ■ L3-26: Additional DC Bus Capacitors

Sets the capacity of any additional DC bus capacitors that have been installed. This data is used in calculations for Single Drive KEB Ride-Thru 2. This setting needs to be adjusted only if external capacity is connected to the drives DC bus and Single Drive KEB 2 is used.

No.	Name	Setting Range	Default
L3-26	Additional DC Bus Capacitors	0 to 65000 $\mu$ F	0 $\mu$ F

### ■ L3-27: Stall Prevention Detection Time

Sets a delay time from when the Stall Prevention level is reached and the actual Stall Prevention function is activated.

No.	Name	Setting Range	Default
L3-27	Stall Prevention Detection Time	0 to 5000 ms	50 ms

## ◆ L4: Speed Detection

These parameters set up the speed agree and speed detection functions which can be assigned to the multi-function output terminals.

### ■ L4-01, L4-02: Speed Agreement Detection Level and Detection Width

Parameter L4-01 sets the detection level for the digital output functions “Speed agree 1,” “User-set speed agree 1,” “Frequency detection 1,” and “Frequency detection 2.”

Parameter L4-02 sets the hysteresis level for these functions.

No.	Name	Setting Range	Default
L4-01	Speed Agreement Detection Level	0.0 to 200.0 Hz	0.0 Hz
L4-02	Speed Agreement Detection Width	0.0 to 20.0 Hz	2.0 Hz

*Refer to H2-01 to H2-03: Terminal M1-M2, M3-M4, and M5-M6 Function Selection on page 190*, Settings 2, 3, 4, and 5.

### ■ L4-03, L4-04: Speed Agreement Detection Level and Detection Width (+/-)

Parameter L4-03 sets the detection level for the digital output functions “Speed agree 2,” “User-set speed agree 2,” “Frequency detection 3,” and “Frequency detection 4.”

Parameter L4-04 sets the hysteresis level for these functions.

No.	Name	Setting Range	Default
L4-03	Speed Agreement Detection Level (+/-)	-200.0 to 200.0 Hz	0.0 Hz
L4-04	Speed Agreement Detection Width (+/-)	0.0 to 20.0 Hz	2.0 Hz

*Refer to H2-01 to H2-03: Terminal M1-M2, M3-M4, and M5-M6 Function Selection on page 190*, Settings 13, 14, 15, and 16.

## 5.8 L: Protection Functions

### ■ L4-05: Frequency Reference Loss Detection Selection

The drive can detect a loss of an analog frequency reference from input A1, A2, or A3. Frequency reference loss is detected when the frequency reference drops below 10% of the reference before or below 5% of the maximum output frequency within 400 ms.

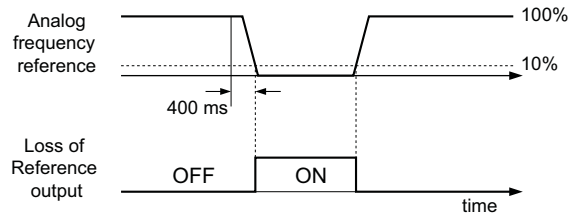


Figure 5.76 Loss of Reference Function

To have a digital output trigger when frequency reference loss occurs, set H2-01, H2-02, or H2-03 to C. [Refer to Setting C: Frequency Reference Loss on page 194](#) for details on setting the output function.

Parameter L4-05 selects the operation when a frequency reference loss is detected.

No.	Name	Setting Range	Default
L4-05	Frequency Reference Loss Detection Selection	0 or 1	1

#### Setting 0: Stop

Drive follows the frequency reference (which is no longer present) and simply stops the motor.

#### Setting 1: Continue operation with reduced frequency reference

The drive will continue operation at the frequency reference value set in parameter L4-06. When the external frequency reference value is restored, the operation is continued with the frequency reference.

### ■ L4-06: Frequency Reference at Reference Loss

Sets the frequency reference level the drive runs with when L4-05 = 1 and a reference loss was detected. The value is set as a percentage of the frequency reference when the loss was detected.

No.	Name	Setting Range	Default
L4-06	Frequency Reference at Reference Loss	0.0 to 100.0%	80.0%

### ■ L4-07: Speed Agreement Detection Selection

Determines when frequency detection is active using parameters L4-01 through L4-04.

No.	Name	Setting Range	Default
L4-07	Speed Agreement Detection Selection	0 or 1	0

#### Setting 0: No detection during baseblock

#### Setting 1: Detection always enabled

## ◆ L5: Fault Restart

After a fault has occurred, this function attempts to automatically restart the motor and continue operation instead of stopping.

The drive can be set up to perform a self-diagnostic check and resume the operation after a fault has occurred. If the self-check is successful and the cause of the fault has disappeared, the drive restarts by first performing Speed Search ([Refer to b3: Speed Search on page 139](#) for details).

- Note:**
1. The wiring sequence should remove the Forward/Reverse command when a fault is triggered and output is shut off.
  2. With the Forward/Reverse command removed, the drive can perform a self-diagnostic check and attempt to reset the fault automatically.

**DANGER!** Never use the fault restart function in hoist-type applications.

The drive can attempt to restart itself following the faults listed below.

Fault	Name	Fault	Name
GF	Ground Fault	oL3	Overtorque 1
LF	Output Open Phase	ov	DC Bus Overvoltage
oC	Overcurrent	PF	Input Phase Loss
oH1	Drive Overheat	Uv1	DC Bus Undervoltage </>
oL1	Motor Overload	Sto	Pull-Out Detection
oL2	Drive Overload		

<1> When L2-01 is set to 1 through 4 (continue operation during momentary power loss)

Use parameters L5-01 to L5-05 to set up automatic fault restart.

To output a signal during fault restart, set H2-01, H2-02, or H2-03 to 1E.

### ■ L5-01: Number of Auto Restart Attempts

Sets the number of times that the drive may attempt to restart itself.

The method of incrementing the restart counter is determined by the setting of parameter L5-05. When the counter reaches the number set in L5-01, the operation stops and the fault has to be reset manually after correcting the cause.

The restart counter is incremented at each restart attempt, regardless of whether the attempt was successful. When the counter reaches the number set in L5-01, the operation stops and the fault has to be reset manually after correcting the cause.

The number of fault restarts is reset back to zero when:

- The drive operates normally for ten minutes following a fault restart.
- A fault is cleared manually after protective functions are triggered.
- The power supply is cycled.

No.	Name	Setting Range	Default
L5-01	Number of Auto Restart Attempts	0 to 10 Times	0 Time

### ■ L5-02: Auto Restart Fault Output Operation Selection

Determines if a fault output is triggered (H2-□□ = E) when the drive attempts to restart.

No.	Name	Setting Range	Default
L5-02	Auto Restart Fault Output Operation Selection	0 or 1	0

**Setting 0: No fault output**

**Setting 1: Fault output is set**

### ■ L5-03: Time to Continue Making Fault Restarts (enabled only when L5-05 = 0)

Although the drive will continue to execute fault restarts, this parameter will cause a fault if a fault restart cannot occur after the time in L5-03 passes.

All major faults will cause the drive to stop. For some faults it is possible to configure the drive to attempt a restart automatically. After the fault occurs, the drive baseblocks for L2-03 seconds. After the baseblock is removed the drive checks if a fault condition still exists. If no fault condition exists the drive will attempt to restart the motor. If the restart is successful, the drive performs a Speed Search (Regardless of the status of b3-01 "Speed Search Selection") from the set speed command and the Auto Restart Attempts count is increased by one. Even if the restart fails the restart count is increased by one as long as the drive attempted to rotate the motor. The restart count will not be incremented if the restart is not attempted due to a continuing fault condition, (i.e. an ov fault). The drive waits L5-03 seconds before attempting another restart.

No.	Name	Setting Range	Default
L5-03	Time to Continue Making Fault Restarts	0.0 to 600.0 s	180.0 s

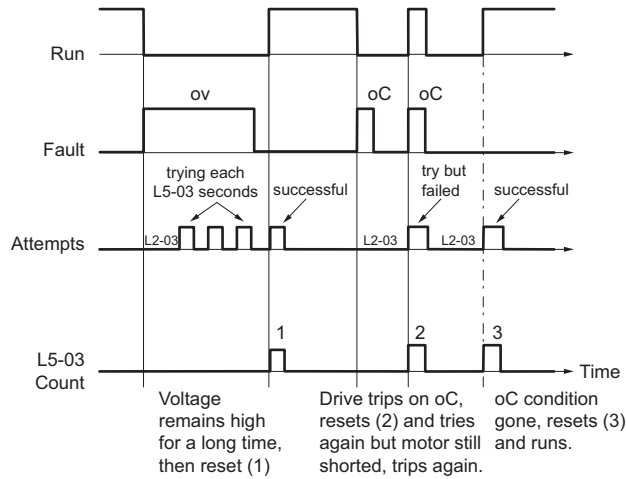


Figure 5.77 Automatic Restart Timing Diagram

The auto restart count is reset back to 0 if any of the following occur:

- No further faults for ten minutes after the last retry.
- The drive's power is turned off (the drive must be without power long enough to let control power dissipate).
- The RESET key is pushed after the last reset attempt.

The setting of parameter L5-02 determines whether the fault output (MA-MB) will be closed during an auto restart attempt.

The setting of L5-02 can be important when interfacing the drive with other equipment.

The following faults will allow the Auto Restart function to initiate:

- oC (Overcurrent)
- LF (Output Phase Loss)
- PF (Input Phase Loss)
- oL1 (Motor Overload)
- oL3 (Overtorque Detection 1)
- oL2 (Drive Overload)
- ov (Overvoltage)
- GF (Ground Fault)
- Uv1 (Undervoltage)
- oH1 (Heatsink Overheat)

In order for auto restart after a Uv1 fault, Momentary Power Loss Ride-thru must be enabled (L2-01= “1: Power Loss Ride-thru Time”, or “2: CPU Power Active”). Setting H2-01, H2-02 or H2-03 equal to “1E” configures a digital output as “Restart Enabled” to signal if an impending auto restart is possible.

■ **L5-04: Fault Reset Interval Time**

Determines the amount of time to wait between restart attempts when parameter L5-05 is set to 1.

No.	Name	Setting Range	Default
L5-04	Fault Reset Interval Time	0.5 to 600.0 s	10.0 s

■ **L5-05: Fault Reset Operation Selection**

No.	Name	Setting Range	Default
L5-05	Fault Reset Operation Selection	0 or 1	0

**Setting 0: Count successful restarts**

The drive will continuously attempt to restart. If it restarts successfully, the restart counter is increased. This operation is repeated each time a fault occurs until the counter reaches the value set in L5-01.

### Setting 1: Count restart attempts

The drive will try to restart using the time interval set in parameter L5-04. A record is kept of the number of attempts to restart to the drive, regardless of whether or not those attempts were successful. When the number of attempted restarts exceeds the value set to L5-01, the drive gives up trying to restart.

## ◆ L6: Torque Detection

The drive provides two independent torque detection functions that trigger an alarm or fault signal when the load is too heavy (oL), or suddenly drops (UL). They are set up using the L6-□□ parameters. To indicate the underload or overload condition to an external device, digital outputs should be programmed as shown below.

**Note:** When overtorque occurs in the application, the drive may stop due to overcurrent (oC) or overload (oL1). To prevent this, an overload situation should be indicated to the controller before oC or oL1 occur in the drive. Use the torque detection for this purpose. Use undertorque detection to discover application problems like a torn belt, a pump shutting off, or other similar trouble.

H2-01, H2-02, H2-03 Setting	Description
B	Torque detection 1, N.O. (output closes when overload or underload is detected)
17	Torque detection 1, N.C. (output opens when overload or underload is detected)
18	Torque detection 2, N.O. (output close when overload or underload is detected)
19	Torque detection 2, N.C. (output opens when overload or underload is detected)

Figure 5.78 and Figure 5.79 show the function of overtorque and undertorque detection.

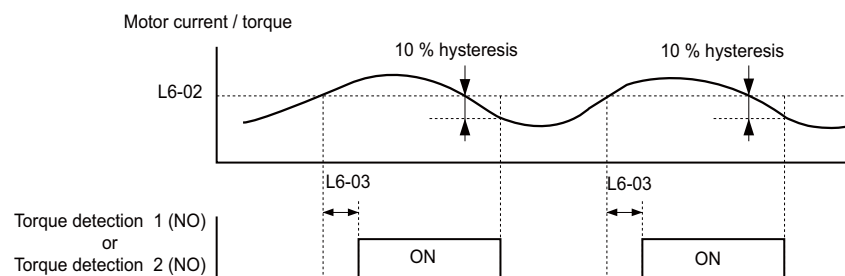


Figure 5.78 Overtorque Detection Operation

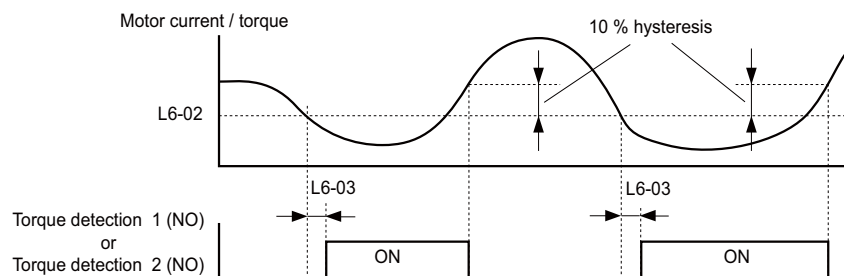


Figure 5.79 Undertorque Detection Operation

- Note:**
1. The torque detection function uses a hysteresis of 10% of the drive rated output current and motor rated torque.
  2. In V/f, and OLV/PM, the level is set as a percentage of the drive rated output current.

### ■ L6-01: Torque Detection Selection

The torque detection function is triggered when the current or torque exceeds the levels set in L6-02 for longer than the time set in L6-03. L6-01 selects the conditions for detection and the operation that follows.

No.	Name	Setting Range	Default
L6-01	Torque Detection Selection 1	0 to 12	0

#### Setting 0: Disabled

#### Setting 1: oL3 at speed agree (Alarm)

Overtorque detection is active only when the output speed is equal to the frequency reference, i.e., no detection during acceleration and deceleration. The operation continues after detection and an oL3 alarm is triggered.

## 5.8 L: Protection Functions

### Setting 2: oL3 at run (Alarm)

Overtorque detection works as long as the Run command is active. The operation continues after detection and an oL3 alarm is triggered.

### Setting 3: oL3 at speed agree (Fault)

Overtorque detection is active only when the output speed is equal to the frequency reference, i.e., no detection during acceleration and deceleration. The operation is stopped and an oL3 fault is triggered.

### Setting 4: oL3 at run (Fault)

Overtorque detection works as long as a Run command is active. Operation stops and an oL3 fault is triggered.

### Setting 5: UL3 at speed agree (Alarm)

Undertorque detection is active only when the output speed is equal to the frequency reference, i.e., no detection during acceleration and deceleration. The operation continues after detection and an UL3 alarm is triggered.

### Setting 6: UL3 at Run (Alarm)

Undertorque detection works as long as the Run command is active. The operation continues after detection and an UL3 or alarm is triggered.

### Setting 7: UL3 at Speed Agree (Fault)

Undertorque detection is active only when the output speed is equal to the frequency reference, i.e., no detection during acceleration and deceleration. The operation is stopped and an UL3 fault is triggered.

### Setting 8: UL3 at run (Fault)

Undertorque detection works as long as a Run command is active. Operation stops and an UL3 fault is triggered.

### Setting 9: UL6 at speed agree (Alarm)

Motor Underload detection is active only when the output speed is equal to the frequency reference, i.e., no detection during acceleration and deceleration. The operation continues after detection and a UL6 alarm is triggered.

### Setting 10: UL6 at run (Alarm)

Motor Underload detection works as long as the Run command is active. The operation continues after detection and a UL6 alarm is triggered.

### Setting 11: UL6 at speed agree (Fault)

Motor Underload detection is active only when the output speed is equal to the frequency reference, i.e., no detection during acceleration and deceleration. The operation is stopped and a UL6 fault is triggered.

### Setting 12: UL6 at run (Fault)

Motor Underload detection works as long as a Run command is active. Operation stops and a UL6 fault is triggered.

## ■ L6-02: Torque Detection Level

This parameter sets the detection level for the torque detection function 1. In V/f and OLV/PM control modes this level is set as a percentage of the drive rated output current.

No.	Name	Setting Range	Default
L6-02	Torque Detection Level 1	0 to 300%	15%

**Note:** The torque detection level 1 (L6-02) can also be supplied by an analog input terminal set to H3-□□ = 7. Here, the analog value has priority and the setting in L6-02 is disregarded.

## ■ L6-03: Torque Detection Time

This parameter determines the time required to trigger an alarm or fault after exceeding the level in L6-02.

No.	Name	Setting Range	Default
L6-03	Torque Detection Time 1	0.0 to 10.0 s	10.0 s



### ■ L6-13: Motor Underload Protection Selection

Sets the Motor Underload Protection (UL6) based on motor load.

Selects the operation of underload detection function UL6. Underload is detected when the output current falls below the underload detection level defined by L6-14 and L2-02. Parameter L6-13 defines what the level of L6-02 refers to, either fbase or fmax.

No.	Name	Setting Range	Default
L6-13	Motor Underload Protection Selection	0 to 1	0

**Setting 0: Fbase Motor load Enabled**

**Setting 1: Fmax base Motor load Enabled**

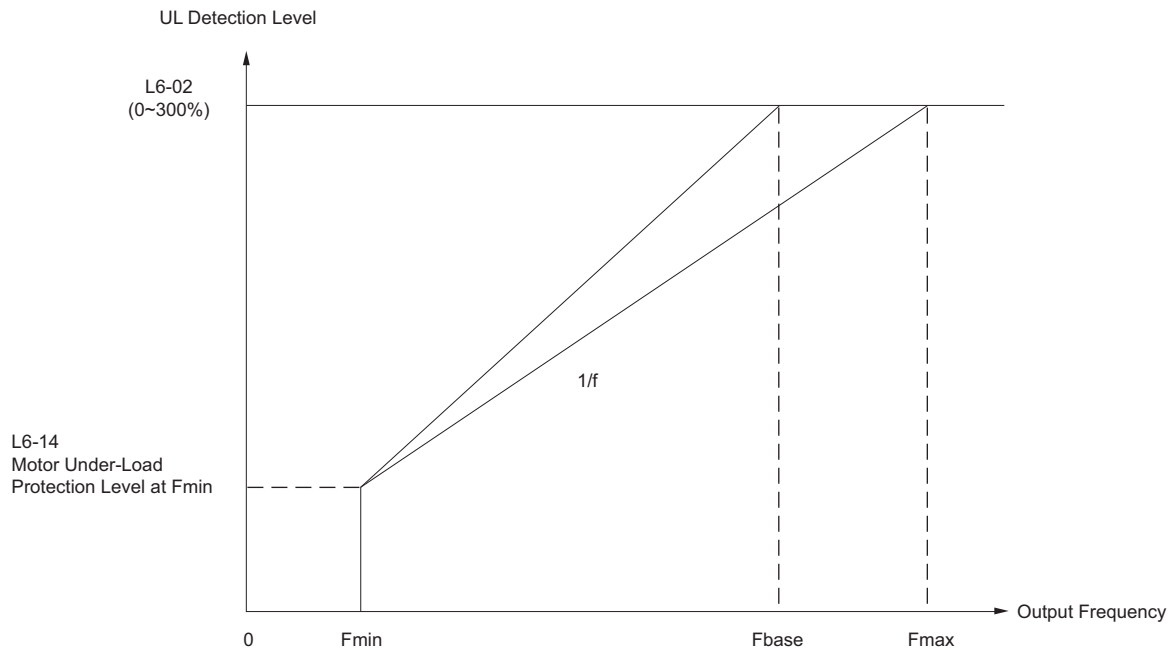


Figure 5.80 Motor Underload Protection

### ■ L6-14: Motor Underload Protection Level at Minimum Frequency

Sets the UL6 detection level at minimum frequency by percentage of drive rated current.

No.	Name	Setting Range	Default
L6-14	Motor Underload Protection Level at Minimum Frequency	0 to 300%	15%

## ◆ L8: Drive Protection

### ■ L8-02: Overheat Alarm Level

Sets the overheat alarm (oH) detection level.

The drive will output an alarm when the heatsink temperature exceeds the alarm level set in parameter L8-02. If the operation when this alarm occurs is set for continued operation (L8-03 = 4) and the temperature reaches the overheat fault level, the drive will trigger an oH1 fault and stop operation.

When an output terminal is set for the oH pre-alarm (H2-□□ = 20), the switch will close when the heatsink temperature rises above L8-02.

No.	Name	Setting Range	Default
L8-02	Overheat Alarm Level	50 to 150 °C	Determined by o2-04

## 5.8 L: Protection Functions

### ■ L8-03: Overheat Pre-Alarm Operation Selection

Sets the operation when an overheat pre-alarm is detected.

**Note:** Change settings only when necessary.

No.	Name	Setting Range	Default
L8-03	Overheat Pre-Alarm Operation Selection	0 to 4	3

#### Setting 0: Ramp to stop

If an overheat alarm occurs, the drive decelerates to stop using the deceleration time currently selected. If a digital output is programmed for “fault” (H2-□□ = E), this output will be triggered.

#### Setting 1: Coast to stop

If heatsink overheat (oH) occurs, the drive switches off the output and the motor coasts to stop. If a digital output is programmed for “fault” (H2-□□ = E), this output will be triggered.

#### Setting 2: Fast Stop

If an overheat alarm occurs, the drive decelerates to stop using the Fast Stop time (C1-09). If a digital output is programmed for “fault” (H2-□□ = E), this output will be triggered.

#### Setting 3: Alarm only

If an overheat alarm occurs, an alarm is output and the drive continues operation.

#### Setting 4: Operation with reduced speed

If an overheat alarm occurs, the operation is continued but the speed is reduced to the level set in parameter L8-19. If after 10 s the oH alarm is still present, the speed is reduced once more. The amount of reduction depends on how often the alarm repeats. If the oH alarm disappears while the drive is operating at a reduced speed, then the drive will switch back to the previous speed it was reduced to before. *Figure 5.81* explains the operation with reduced speed during an oH alarm. A digital output programmed for 4D is switched when the oH alarm is still active after ten reduction cycles.

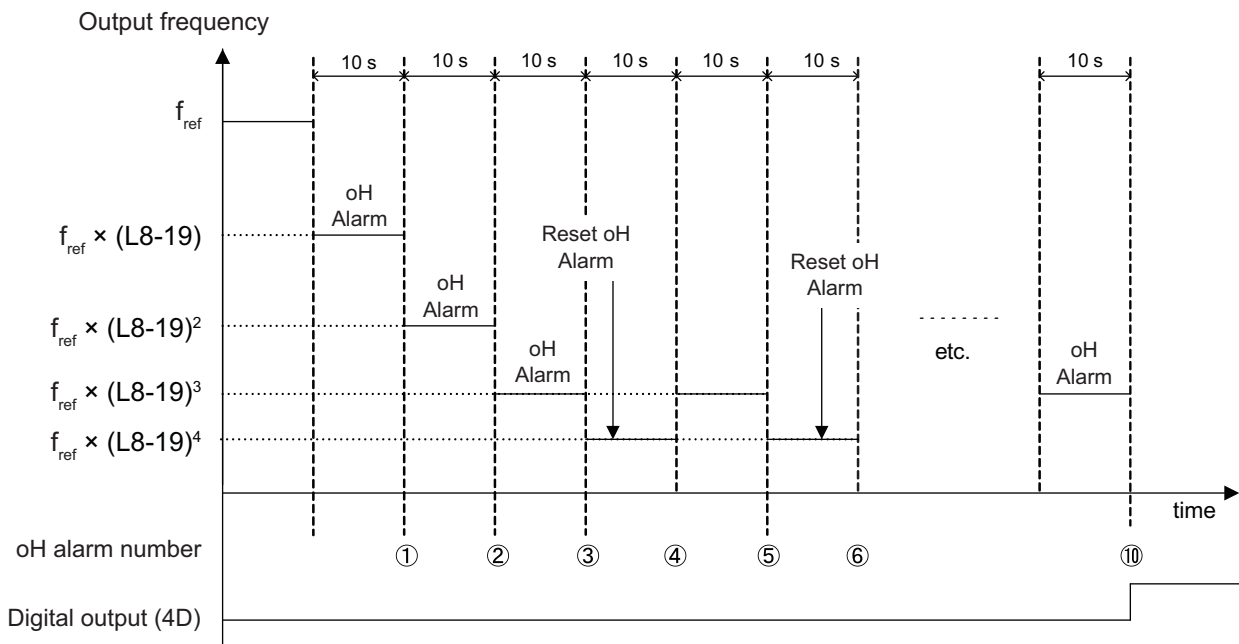


Figure 5.81 Output Frequency Reduction During Overheat Alarm

### ■ L8-19: Frequency Reduction Rate during Overheat Pre-Alarm

Specifies how much the output frequency is reduced when L8-03 is set to 4 and an oH alarm is present. Set as a factor of the maximum output frequency.

No.	Name	Setting Range	Default
L8-19	Frequency Reduction Rate During Overheat Pre-Alarm	0.1 to 0.9	0.8

### ■ L8-05: Input Phase Loss Protection Selection

Enables or disables the input phase loss detection.

No.	Name	Setting Range	Default
L8-05	Input Phase Loss Protection Selection	0 or 1	1

#### Setting 0: Disabled

#### Setting 1: Enabled

Enables input phase loss detection. As detection is performed by measuring the DC bus ripple, a phase loss fault (PF) can also be triggered by a power supply voltage imbalance or main circuit capacitor deterioration. Detection is disabled if:

- The drive is decelerating.
- No Run command is active.
- Output current is less than or equal to 30% of the drive rated current.

### ■ L8-06: Input Phase Loss Detection Level

Sets the Input Phase Loss Detection (PF) Level.

Triggers PF fault when there is an imbalance larger than the value set to L8-06 in the drive input power voltage.

Detection Level = 100% = Voltage Class  $\times \sqrt{2}$

No.	Name	Setting Range	Default
L8-06	Input Phase Loss Detection Level	0.0 to 50.0%	Determined by o2-04

### ■ L8-07: Output Phase Loss Protection Selection

Enables or disables the output phase loss detection, which is triggered when the output current falls below 5% of the drive rated current.

- Note:**
1. Output phase loss detection can mistakenly be triggered if the motor rated current is very small compared to the drive rating. Disable this parameter in such cases.
  2. Output phase loss detection is not possible when the drive is running a PM motor with light load.

No.	Name	Setting Range	Default
L8-07	Output Phase Loss Protection Selection	0 to 2	0

#### Setting 0: Disabled

#### Setting 1: Fault when one phase is lost

An output phase loss fault (LF) is triggered when one output phase is lost. The output shuts off and the motor coasts to stop.

#### Setting 2: Fault when two phases are lost

An output phase loss fault (LF) is triggered when two output phases are lost. The output shuts off and the motor coasts to stop.

### ■ L8-09: Output Ground Fault Detection Selection

Enables or disables the output ground fault detection.

No.	Name	Setting Range	Default
L8-09	Output Ground Fault Detection Selection	0 or 1	1

#### Setting 0: Disabled

Ground faults are not detected.

#### Setting 1: Enabled

A ground fault (GF) is triggered when high leakage current or a ground short circuit occurs in one or two output phases.

## 5.8 L: Protection Functions

### ■ L8-10: Heatsink Cooling Fan Operation Selection

Selects the heatsink cooling fan operation.

No.	Name	Setting Range	Default
L8-10	Heatsink Cooling Fan Operation Selection	0 or 1	0

#### Setting 0: Run with timer

The fan is switched on when a Run command is active. It is switched off with the delay set in parameter L8-11 after the Run command has been released. Using this setting extends the fan lifetime.

#### Setting 1: Run always

The fan runs whenever power is supplied to the drive.

### ■ L8-11: Heatsink Cooling Fan Off-Delay Time

Sets the cooling fan switch off-delay time if parameter L8-10 is set to 0.

No.	Name	Setting Range	Default
L8-11	Heatsink Cooling Fan Off-Delay Time	0 to 300 s	60 s

### ■ L8-12: Ambient Temperature Setting

If the temperature where the drive is mounted is above the specified values, the drive rated current must be reduced for optimal performance life. By setting the ambient temperature to parameter L8-12 and adjusting the installation method setting in L8-35, the drive rating automatically adapts to safe values.

No.	Name	Setting Range	Default
L8-12	Ambient Temperature Setting	-10 to 50 °C	40 °C

### ■ L8-15: oL2 Characteristics Selection at Low Speeds

Selects whether the drive overload capability (oL fault detection level) is reduced at low speeds in order to prevent premature output transistor failures.

**Note:** Contact Yaskawa for consultation first before disabling this setting.

No.	Name	Setting Range	Default
L8-15	oL2 Characteristics Selection at Low Speed	0 or 1	1

#### Setting 0: Protection disabled at low speed

The overload protection level is not reduced. Frequently operating the drive with high output current at low speed can lead to premature drive faults.

#### Setting 1: protection enabled at low speed

The overload protection level (oL2 fault detection level) is automatically reduced at speeds below 6 Hz.

### ■ L8-18: Software Current Limit Selection

The Software Current Limit (CLA) is a drive protection function that prevents main circuit transistor failures caused by high current. Parameter L8-18 enables or disables this function.

**Note:** This setting should not be changed unless absolutely necessary. For proper drive protection and operation leave the Software CLA function enabled.

No.	Name	Setting Range	Default
L8-18	Software Current Limit Selection	0 or 1	0

#### Setting 0: Software CLA disabled (gain = 0)

The drive may trip on an oC fault if the load is too heavy or the acceleration is too short.

#### Setting 1: Software CLA enabled

When the soft CLA current level is reached, the drive reduces the output voltage in order to reduce the current. If the current level drops below the Software CLA level, then normal operation will continue.

### ■ L8-27: Overcurrent Detection Gain

Adjusts the overcurrent detection level when running in OLV/PM. A setting of 100% is equal to the motor rated current. When the drive rated current is considerably higher than the motor rated current, use this parameter to decrease the overcurrent level in order to prevent motor demagnetization by too high current.

Overcurrent detection will use whichever value is the lowest: the overcurrent level for the drive, or the motor rated current multiplied by L8-27.

No.	Name	Setting Range	Default
L8-27	Overcurrent Detection Gain	0.0 to 300.0%	300.0%

### ■ L8-29: Current Unbalance Detection (LF2)

Enables or disables output current imbalance detection when running in OLV/PM. Current unbalance can heat up a PM motor and lead to demagnetization of the magnets. The current imbalance detection function prevents such motor damage by monitoring output current and triggering the LF2 fault when current unbalance occurs.

No.	Name	Setting Range	Default
L8-29	Current Unbalance Detection (LF2)	0 or 1	1

#### Setting 0: Disabled

No current unbalance protection is provided to the motor.

#### Setting 1: Enabled

The LF2 fault is triggered if an output current imbalance is detected. Drive output shuts off and the motor coasts to stop.

### ■ L8-32: Main Contactor and Cooling Fan Power Supply Failure Selection

Determines drive operation when a FAn fault occurs.

No.	Name	Setting Range	Default
L8-32	Main Contactor and Cooling Fan Power Supply Failure Selection	0 to 4	1

#### Setting 0: Ramp to stop

The drive stops the motor using the deceleration time<sub>1</sub> set in parameter C1-02.

#### Setting 1: Coast to stop

The drive output is switched off and the motor coasts to stop.

#### Setting 2: Fast Stop

The drive stops the motor using the Fast stop time set in parameter C1-09.

#### Setting 3: Alarm only

The operation is continued and a FAn alarm is displayed on the digital operator.

#### Setting 4: Operation with reduced speed

The operation is continued but the speed is reduced to the level set in parameter L8-19.

**Note:** FAn is detected as an error when setting 0 to 2 is selected. It is detected as an alarm when setting 3 or 4 is selected.

### ■ L8-35: Installation Method Selection

Selects the type of installation for the drive and changes the drive overload (oL2) limits accordingly.

- Note:**
1. This parameter is not reset when the drive is initialized.
  2. The value is preset to the appropriate value when the drive is shipped. Change the value only when using Side-by-Side installation or when mounting a standard drive with the heatsink outside the cabinet.

No.	Name	Setting Range	Default
L8-35	Installation Method Selection	0 to 3	Determined by o2-04

#### Setting 0: IP00 enclosure

For an IP00 enclosure drive installed with at a minimum of 30 mm space to the next drive or a cabinet wall.

## 5.8 L: Protection Functions

### Setting 1: Side-by-Side mounting

For drives mounted according to Yaskawa's Side-by-Side specifications (requires 2 mm between drives).

### Setting 2: IP20 or NEMA Type 1 enclosure

For drives compliant with IP20 or NEMA Type 1 enclosure specifications.

### Setting 3: Finless drive or external heatsink Installation

For finless drives or a standard drive mounted with the heatsink outside the cabinet or enclosure panel.

#### ■ L8-38: Carrier Frequency Reduction Selection

Lets the drive reduce the carrier frequency when the output current exceeds a certain level. This temporarily increases the overload capability (oL2 detection), allowing the drive to run through transient load peaks without tripping.

L8-38 selects the operation of the carrier frequency reduction function.

No.	Name	Setting Range	Default
L8-38	Carrier Frequency Reduction Selection	0 to 2	Determined by A1-02, o2-04

#### Setting 0: Disabled

No carrier frequency reduction at high current.

#### Setting 1: Enabled for output frequencies below 6 Hz

The carrier frequency is reduced at speeds below 6 Hz when the current exceeds 100% of the drive rated current. The drive returns to its normal carrier frequency when the current falls below 88% or the output frequency exceeds 7 Hz.

#### Setting 2: Enabled for entire frequency range

The carrier frequency is reduced at the following speeds:

- Below 6 Hz when the current exceeds 100% of the drive rated current.
- Above 7 Hz when the current exceeds 112% of the drive rated current.

The drive uses the delay time set in parameter L8-40 and a hysteresis of 12% when switching the carrier frequency back to the set value.

#### ■ L8-40: Carrier Frequency Reduction Off-Delay Time

Sets a hold time before returning to the original carrier frequency setting after the carrier frequency has been temporarily derated as determined by L8-38. The carrier frequency reduction function is disabled if this value is 0.00 s.

No.	Name	Setting Range	Default
L8-40	Carrier Frequency Reduction Off-Delay Time	0.00 to 2.00 s	Determined by A1-02

#### ■ L8-41: High Current Alarm Selection

Triggers a high current alarm (HCA) when the output current rises too much.

No.	Name	Setting Range	Default
L8-41	High Current Alarm Selection	0 or 1	0

#### Setting 0: Disabled

No alarm is detected.

#### Setting 1: Enabled

An alarm is triggered when the output current exceeds 150% of the drive rated current. A digital output set for an alarm (H2-□□ = 10) will close.

### ■ L8-78: Power Unit Output Phase Loss Protection

Protects the power unit from phase loss.

**Note:** This parameter is available in models CIMR-E□4A0930 and 4A1200.

No.	Name	Setting Range	Default
L8-78	Power Unit Output Phase Loss Protection	0, 1	1

**Setting 0: Disabled**

**Setting 1: Enabled**

## 5.9 n: Special Adjustments

These parameters handle a variety of specialized adjustments and functions, including Hunting Prevention, High Slip Braking, and PM motor control functions.

### ◆ n1: Hunting Prevention

Hunting Prevention keeps the drive from hunting as a result of low inertia and operating with light load. Hunting often occurs with a high carrier frequency and an output frequency below 30 Hz.

#### ■ n1-01: Hunting Prevention Selection

Enables or disables the Hunting Prevention function.

**Note:** This function is available only when using V/f Control. Hunting Prevention should be disabled when drive response is more important than suppressing motor oscillation. This function can also be disabled without any problems in applications with high inertia loads or relatively heavy loads.

No.	Name	Setting Range	Default
n1-01	Hunting Prevention Selection	0 or 1	1

**Setting 0: Disabled**

**Setting 1: Enabled**

#### ■ n1-02: Hunting Prevention Gain Setting

Sets the gain for the Hunting Prevention Function.

No.	Name	Setting Range	Default
n1-02	Hunting Prevention Gain Setting	0.00 to 2.50	1.00

Normally, n1-02 does not need to be changed, but adjustment may help under the following conditions:

- If the motor vibrates while lightly loaded and n1-01 = 1, increase the gain by 0.1 until vibration ceases.
- If the motor stalls while n1-01 = 1, decrease the gain by 0.1 until the stalling ceases.

#### ■ n1-03: Hunting Prevention Time Constant

Determines how responsive the Hunting Prevention function is (affects the primary delay time for Hunting Prevention).

No.	Name	Setting Range	Default
n1-03	Hunting Prevention Time Constant	0 to 500 ms	Determined by o2-04

Normally, n1-03 does not need to be changed, but adjustment may help under the following conditions:

- Increase this value for applications with a large load inertia. A higher setting leads to slower response, though, which can result in oscillation at lower frequencies.
- Lower this setting if oscillation occurs at low speed.

#### ■ n1-05: Hunting Prevention Gain while in Reverse

This parameter is the same as n1-02, except that it is used when rotating in reverse. See the explanation for n1-02.

**Note:** When set to 0 ms, n1-02 is enabled even when the drive is operating in reverse.

No.	Name	Setting Range	Default
n1-05	Hunting Prevention Gain while in Reverse	0.00 to 2.50	0.00



## ◆ n3: High Slip Braking (HSB) and Overexcitation Braking

### ■ High Slip Braking (V/f)

HSB works in V/f Control only and is used to decrease the stopping time compared to normal deceleration without using braking resistor options. HSB stops the motor by reducing the output frequency in large steps, thus producing a high slip. Regenerative energy created from decelerating the load is dissipated in the motor windings through increased motor slip. Because of the increased temperature of the motor windings, HSB should not be used for frequently stopping the motor.

#### Notes on using High Slip Braking:

- The deceleration time that has been set is ignored during HSB. Use Overexcitation Deceleration 1 (L3-04 = 4) or a dynamic braking options if the motor has to be stopped in a defined time.
- Braking time varies based on the load inertia and motor characteristics.
- HSB and KEB Ride-Thru cannot be used simultaneously. If enabled at the same time, an oPE03 will occur.
- HSB must be triggered by a digital input set to H1-□□ = 68. Once the HSB command is given, it is not possible to restart the drive until the motor has stopped completely and the Run command is cycled.
- Use parameters n3-01 through n3-04 for adjusting HSB.

### ■ n3-01: High Slip Braking Deceleration Frequency Width

Sets the step width for frequency reduction during HSB. Increase n3-01 if DC bus overvoltage (ov) occurs during HSB.

No.	Name	Setting Range	Default
n3-01	High Slip Braking Deceleration Frequency Width	1 to 20%	5%

### ■ n3-02: High Slip Braking Current Limit

Sets the maximum current to be output during an HSB stop as a percentage of motor rated current (E2-01). Reducing the current limit increases the deceleration time. Make sure that this value does not exceed the drive's current rating.

- Lower this setting if overvoltage occurs during HSB.
- Lower this setting if motor current is too high during HSB. High current can damage the motor due to overheat.
- The default setting is 120%.

No.	Name	Setting Range	Default
n3-02	High Slip Braking Current Limit	100 to 200%	Determined by L8-38

### ■ n3-03: High Slip Braking Dwell Time at Stop

When the motor reaches a relatively low speed at the end of HSB, the output frequency is kept at the minimum output frequency E1-09 for the time set in n3-03. Increase this time if the inertia is very high and the motor is still coasting after HSB is complete.

No.	Name	Setting Range	Default
n3-03	High Slip Braking Dwell Time at Stop	0.0 to 10.0 s	1.0 s

### ■ n3-04: High Slip Braking Overload Time

Sets the time required for an HSB overload fault (oL7) to occur when the drive output frequency does not change for some reason during an HSB stop. This can be caused by the load rotating the motor or by excessive load inertia, resulting in a high current. To protect the motor from overheat, the drive trips with an oL7 fault if such these conditions lasts longer than the time set in n3-04.

No.	Name	Setting Range	Default
n3-04	High Slip Braking Overload Time	30 to 1200 s	40 s

### ■ Overexcitation Deceleration (Induction Motors)

Overexcitation Deceleration increases the flux during deceleration and allows shorter deceleration time settings without the use of a braking resistor. Enabled by setting L3-04 to 4 or 5. See [L3-04: Stall Prevention Selection during Deceleration on page 223](#).

#### Notes on Overexcitation Deceleration

- As regenerative energy is mainly dissipated as heat in the motor, the motor temperature will rise if Overexcitation Deceleration is applied frequently. In such cases, make sure the motor temperature does not exceed the maximum allowable value or consider using a braking resistor option instead.
- During Overexcitation Deceleration 2, Hunting Prevention in V/f Control is disabled.
- Do not use Overexcitation Deceleration in combination with a braking resistor option.
- Overexcitation Deceleration can be most efficiently used in a V/f Control.
- Overexcitation Deceleration cannot be used with PM motors.

#### Parameter Adjustments

- Use parameters n3-13 through n3-23 for adjusting Overexcitation Deceleration.
- When repetitive or long Overexcitation Deceleration results in motor overheat, lower the overexcitation gain (n3-13) and reduce the overslip suppression current level (n3-21).
- During Overexcitation Deceleration 1 (L3-04 = 4), the drive decelerates at the active deceleration time (C1-02 or C1-04). Make sure to set this time so that no overvoltage (ov) fault occurs.
- During Overexcitation Deceleration 2 (L3-04 = 5), the drive decelerates using the active deceleration time while adjusting the deceleration rate in order to keep the DC bus voltage at the level set in L3-17. The actual stopping time will be longer or shorter than the set deceleration time, depending on the motor characteristics and the load inertia. If overvoltage occurs (ov), try increasing the deceleration time.
- When a Run command is entered during Overexcitation Deceleration, overexcitation operation is cancelled and the drive will reaccelerate to the specified speed.

### ■ n3-13: Overexcitation Deceleration Gain

Multiplies a gain to the V/f pattern output value during Overexcitation Deceleration, thereby determining the level of overexcitation. The drive returns to the normal V/f value after the motor has stopped or when it is accelerating to the frequency reference.

No.	Name	Setting Range	Default
n3-13	Overexcitation Deceleration Gain	1.00 to 1.40	1.10

The optimum setting for n3-13 depends on the motor flux saturation characteristics.

- Increase the gain gradually by 1.25 to 1.30 to improve the braking power of Overexcitation Deceleration.
- If flux saturation characteristics cause overcurrent, try lowering n3-13. A high setting sometimes causes overcurrent (oC), motor overload (oL1), or drive overload (oL2). Lowering n3-21 can also help remedy these problems.

### ■ n3-21: High Slip Suppression Current Level

If the motor current exceeds the value set to n3-21 during Overexcitation Deceleration due to flux saturation, the drive will automatically reduce the overexcitation gain. Parameter n3-21 is set as a percentage of the drive rated current.

This parameter should be set to a relatively low value to optimize deceleration. If overcurrent, oL1, or oL2 occur during Overexcitation Deceleration, reduce the overslip suppression current level.

No.	Name	Setting Range	Default
n3-21	High Slip Suppression Current Level	0 to 150%	100%

### ■ n3-23: Overexcitation Operation Selection

Limit the Overexcitation Deceleration operation selected in parameter L3-04 to forward only or reverse only.

No.	Name	Setting Range	Default
n3-23	Overexcitation Operation Selection	0 to 2	0

**Setting 0: Overexcitation Operation as Selected in L3-04 in Forward and Reverse Direction**

**Setting 1: Overexcitation Operation as Selected in L3-04 in Forward Direction Only**

**Setting 2: Overexcitation Operation as Selected in L3-04 in Reverse Direction Only**

### ◆ n8: PM Motor Control Tuning

These parameters are available in the vector control modes for permanent magnet motors and can be used to adjust the control performance.

#### ■ n8-45: Speed Feedback Detection Control Gain (OLV/PM)

Sets the gain for internal speed feedback detection control. Although this setting rarely needs to be changed, adjustment may be necessary under the following conditions:

- Increase this setting if motor oscillation or hunting occurs.
- Decrease this setting in increments of 0.05 to decrease drive responsiveness.

No.	Name	Setting Range	Default
n8-45	Speed Feedback Detection Control Gain	0.00 to 10.00	0.80

#### ■ n8-47: Pull-In Current Compensation Time Constant (OLV/PM)

Sets the time constant for the actual current and the pull-in current to match one another.

Although this setting rarely needs to be changed, adjustment may be necessary under the following conditions:

- Increase this setting when it takes too long for the reference value of the pull-in current to match the target value.
- Decrease this setting if motor oscillation occurs.

No.	Name	Setting Range	Default
n8-47	Pull-In Current Compensation Time Constant	0.0 to 100.0 s	5.0 s

#### ■ n8-48: Pull-In Current (OLV/PM)

Sets the d-axis current during no-load operation at a constant speed. Set as a percentage of the motor rated current.

- Increase this setting when hunting occurs or the motor speed is unstable while running at a constant speed.
- If there is too much current when driving a light load at a constant speed, then reduce this value slightly.

No.	Name	Setting Range	Default
n8-48	Pull-In Current	20 to 200%	30%

#### ■ n8-49: d-Axis Current for High Efficiency Control (OLV/PM)

Sets the d-axis current reference when running with high load at constant speed. When using an IPM motor, setting this parameter will increase the efficiency by using the motors reluctance torque and thereby reduce the energy consumption. This parameter should be set to 0 when using an SPM motor.

Although this setting seldom needs to be changed, please note the following:

- If motor operation is unstable when driving heavy loads, try lowering this setting.
- If motor parameters (E5-□□) have been changed, this value will be reset to 0 and will need to be readjusted.

No.	Name	Setting Range	Default
n8-49	d Axis Current for High Efficiency Control	-200.0 to 0.0%	Determined by E5-01

## 5.9 n: Special Adjustments

### ■ n8-51: Acceleration/Deceleration Pull-In Current (OLV/PM)

Sets the pull-in current during acceleration and deceleration as a percentage of the motor rated current (E5-03).

Adjustments to this setting may help in the following situations:

- Increase this setting when a large amount of starting torque is required.
- Lower this setting if there is excessive current during acceleration.

No.	Name	Setting Range	Default
n8-51	Acceleration/Deceleration Pull-In Current	0 to 200%	50%

### ■ n8-54: Voltage Error Compensation Time Constant (OLV/PM)

Sets the time constant for voltage error compensation. Make changes to this parameter under the following conditions:

- Adjust the value when hunting occurs at low speed.
- Increase the value in steps of 0.1 when hunting occurs with sudden load changes. Try to disable the compensation by setting n8-51 = 0 if increasing n8-54 does not help.
- Increase the value when oscillations occur at start.

No.	Name	Setting Range	Default
n8-54	Voltage Error Compensation Time Constant	0.00 to 10.00	1.00

### ■ n8-55: Load Inertia (OLV/PM)

Sets the ratio between motor inertia and the inertia of the connected machinery. If this value is set too low, the motor may not start very smoothly, and the STo fault (Motor Step-Out) may occur.

For large inertia loads or to improve speed control response, increase this setting from 0. Oscillations may occur if this value is set too high with low inertia load.

No.	Name	Setting Range	Default
n8-55	Load Inertia	0 to 3	0

#### Setting 0: Below 1:10

The inertia ratio between the motor and the load is just less than 1:10.

#### Setting 1: Between 1:10 and 1:30

The inertia ratio between the motor and the load is between 1:10 and 1:30. Set n8-55 to 1 if an STo fault occurs as a result of impact load or sudden acceleration/deceleration when n8-55 = 0.

#### Setting 2: Between 1:30 and 1:50

The inertia ratio between the motor and the load is between 1:30 and 1:50. Set n8-55 to 2 if an STo fault occurs as a result of impact load or sudden acceleration/deceleration when n8-55 = 1.

#### Setting 3: Beyond 1:50

The inertia ratio between the motor and the load is higher than 1:50. Set n8-55 to 3 if an STo fault occurs as a result of impact load or sudden acceleration/deceleration when n8-55 = 2.

### ■ n8-62: Output Voltage Limit

Sets the output voltage limit to prevent voltage saturation. This parameter rarely requires adjustment. Never set this value higher than the actual input voltage.

No.	Name	Setting Range	Default
n8-62 <1>	Output Voltage Limit	0.0 to 230.0 Vac	200 Vac

<1> Values shown here are for 200 V class drives. Double values when using a 400 V class unit.

**■ n8-65: Speed Feedback Detection Control Gain during ov Suppression (OLV/PM)**

Sets the gain for internal speed feedback detection control when overvoltage suppression is active. Although this setting rarely needs to be changed, adjustment may be necessary under the following conditions:

- Increase this setting if motor oscillation or hunting occurs when ov suppression is active.
- Decrease this setting in increments of 0.05 to decrease the drive responsiveness during ov suppression.

No.	Name	Setting Range	Default
n8-65	Speed Feedback Detection Control Gain during ov Suppression (OLV/PM)	0.00 to 10.00	1.50

## 5.10 o: Operator Related Settings

These parameters are for controlling the various functions, features, and display of the digital operator.

### ◆ o1: Digital Operator Display Selection

These parameters determine how data appears on the operator display.

#### ■ o1-01: Drive Mode Unit Monitor Selection

When the drive is powered up, the monitor selected in parameter o1-02 appears first on the display. If o1-02 is set to 5, o1-01 can be used to change the content of this monitor.

When using an LED operator, pressing the up arrow key will display the following data: speed reference → rotational direction → output speed → output current → o1-01 selection.

Parameter o1-01 lets the user select the content of the last monitor in this sequence. There is no effect like this on an LCD operator.

No.	Name	Setting Range	Default
o1-01	Drive Mode Unit Monitor Selection	105 to 825 U1-05 (Motor Speed) to U8-25(DWEZ Custom Monitor 25) </>	106 (U1-06)

<1> U2-□□ and U3-□□ parameters cannot be selected.

#### ■ o1-02: User Monitor Selection after Power Up

Selects which monitor parameter is displayed upon power up. This is done by entering the 1□□ part of U1-□□. Certain monitors are not available in some control modes. *Refer to U: Monitor Parameters on page 253* for a list of monitors.

No.	Name	Setting Range	Default
o1-02	User Monitor Selection after Power Up	1 to 5	1

**Setting 1: Frequency reference (U1-01)**

**Setting 2: Motor direction**

**Setting 3: Output frequency (U1-02)**

**Setting 4: Output current (U1-03)**

**Setting 5: User-selected monitor (set by o1-01)**

#### ■ o1-03: Digital Operator Display Selection

Sets the units used to display the frequency reference and output frequency. Set o1-03 to 3 for user-set units, then set parameters o1-10 and o1-11.

No.	Name	Setting Range	Default
o1-03	Digital Operator Display Selection	0 to 3	0

**Setting 0: 0.01 Hz units**

**Setting 1: 0.01% units (100% = max. output frequency)**

**Setting 2: r/min units (calculated by the max output frequency and the no. of motor poles)**

**Setting 3: User-set units (use o1-10, o1-11)**

Set the value use for the maximum frequency reference to o1-10. The placement of the decimal point in this number should be set to o1-11.

For example, to have the maximum output frequency displayed as “100.00”, set the o1-10 = 1000 and o1-11 = 2 (i.e., 1000 with 2 decimal points).

**Note:** 1. Parameter o1-03 allows the programmer to change the units used in the following parameters and monitors:

- U1-01: frequency reference
- U1-02: output frequency
- U1-16: output frequency after softstarter (accel/decel ramp generator)
- d1-01 to d1-17: frequency references

2. Setting o1-03 to 2 requires that the number of motor poles be entered to E2-04 and E5-04.

### ■ o1-06: User Monitor Selection Mode

Normally the monitors shown directly below the active monitor are the next two sequential monitors. If o1-06 (User Monitor Selection Mode) is set to “1: 3 Mon Selectable”, those two monitors are locked as specified by parameters o1-07 and o1-08 and will not change as the top parameter is scrolled with the Up/Down Arrow keys.

No.	Name	Setting Range	Default
o1-06	User Monitor Selection Mode	0, 1	0

**0: 3 Monitor Sequential (Displays the next 2 sequential monitor)**

**1: 3 Monitor Selectable: o1-07, and o1-08 selected monitor is shown**

### ■ o1-07: Second Line Monitor Selection

Selects which monitor will be displayed in the second line. The monitor parameter number is entered into the spaces provided: U□-□□.

For example, set “403” to display monitor parameter U4-03.

No.	Name	Setting Range	Default
o1-07	Second Line Monitor Selection	101 to 825	102

### ■ o1-08: Third Line Monitor Selection

Selects which monitor will be displayed in the third line. The monitor parameter number is entered into the spaces provided: U□-□□.

For example, set “403” to display monitor parameter U4-03.

No.	Name	Setting Range	Default
o1-08	Third Line Monitor Selection	101 to 825	103

### ■ o1-10: User-Set Display Units Maximum Value

Determines the display value that is equal to the maximum output frequency.

No.	Name	Setting Range	Default
o1-10	User-Set Display Units Maximum Value	1 to 60000	Determined by o1-03

### ■ o1-11: User-Set Display Units Decimal Display

Determines how many decimal points should be used to set and display the frequency reference.

No.	Name	Setting Range	Default
o1-11	User-Set Display Units Decimal Display	0 to 3	Determined by o1-03

**Setting 0: No decimal point**

**Setting 1: One decimal point**

**Setting 2: Two decimal points**

**Setting 3: Three decimal points**

## ◆ o2: Digital Operator Keypad Functions

These parameters determine the functions assigned to the operator keys.

### ■ o2-01: LO/RE (LOCAL/REMOTE) Key Function Selection

Parameter o2-01 determines whether the LO/RE key on the digital operator will be enabled or not for switching between LOCAL and REMOTE.

No.	Name	Setting Range	Default
o2-01	LO/RE Key Function Selection	0 or 1	1

**Setting 0: Disabled**

The LO/RE key is disabled.

## 5.10 o: Operator Related Settings

### Setting 1: Enabled

The LO/RE switches between LOCAL and REMOTE operation. Switching is possible during stop only. When LOCAL is selected, the LED indicator on the LO/RE key will light up.

**WARNING!** *Sudden Movement Hazard. The drive may start unexpectedly if the Run command is already applied when switching from LOCAL mode to REMOTE mode when b1-07 = 1, resulting in death or serious injury. Check all mechanical or electrical connections thoroughly before making any setting changes to o2-01 and b1-07. Table 5.32 lists the setting combinations for o2-01 and b1-07.*

**Table 5.32 LO/RE Key and b1-07**

o2-01	b1-07	Switch from LOCAL to REMOTE	Switch from REMOTE to LOCAL
0	0	Not possible	Not possible
	1	Not possible	Not possible
1	0	Will not run until a new Run command is entered.	Run not possible
	1	If a Run command is entered, the drive will start running as soon as the LO/RE key is pushed to change from LOCAL to REMOTE.	Run not possible

### ■ o2-02: STOP Key Function Selection

Determines if the STOP key on the digital operator can still be used to stop drive operation when the drive is being controlled from a remote source (i.e., not from digital operator).

No.	Name	Setting Range	Default
o2-02	STOP Key Function Selection	0 or 1	1

#### Setting 0: Disabled

#### Setting 1: Enabled

The STOP key can be used to terminate drive operation, even if the Run command source is not assigned to the digital operator. If the drive is stopped by pressing the STOP key, the Run command must be cycled to restart the drive.

### ■ o2-03: User Parameter Default Value

Once drive parameters are set up completely, the values set can be saved as user-set default values using parameter o2-03. Once this has been done, the “Initialize Parameters” parameter (A1-03) will offer the choice of “1110: User Initialize”. Choosing A1-03 = “1110: User Initialize” will reset all parameters to the values saved as user-set defaults. [Refer to A1-03: Initialize Parameters on page 127](#) for details on drive initialization.

No.	Name	Setting Range	Default
o2-03	User Parameter Default Value	0 to 2	0

#### Setting 0: No change (awaiting command)

#### Setting 1: Set User Initialize values

The current parameter settings are saved as user-set default for a later User Initialize. Once o2-03 is set to 1 and the ENTER key is pressed, the values are saved and the display returns to 0.

#### Setting 2: Clear User Initialize Values

All user-set defaults for “User Initialize” are cleared. Once o2-03 is set to 2 and the ENTER key is pressed, the values are erased and the display returns to 0.

### ■ o2-04: Drive Model Selection

This parameter must be set when replacing the control board or the terminal board for any reason.

**NOTICE:** *Drive performance will suffer if the correct drive capacity is not set to o2-04, and protective functions will fail to operate properly.*

No.	Name	Setting Range	Default
o2-04	Drive Model Selection	-	Determined by drive capacity

**Note:** Change settings only when necessary.



### ■ o2-05: Frequency Reference Setting Method Selection

Determines if the ENTER key must be pressed after changing the frequency reference using the digital operator while in the Drive Mode.

No.	Name	Setting Range	Default
o2-05	Frequency Reference Setting Method Selection	0 or 1	0

#### Setting 0: ENTER key required

Every time the frequency reference is changed using the digital operator, the ENTER key must be pressed for the drive to accept the change.

#### Setting 1: ENTER key not required

The output frequency changes immediately when the reference is changed by the up or down arrow keys on the digital operator. The ENTER key does not need to be pressed. The frequency reference (Fref) is saved to memory after remaining unchanged for 5 seconds.

### ■ o2-06: Operation Selection when Digital Operator is Disconnected

Determines if the drive will stop when the digital operator is removed in LOCAL mode or when b1-02 or b1-16 is set to 0. When the operator is reconnected, the display will indicate that it was disconnected.

No.	Name	Setting Range	Default
o2-06	Digital Operator Disconnection Operation	0 or 1	0

#### Setting 0: Continue operation

The operation is continued.

#### Setting 1: Trigger a fault

The operation is stopped and an “oPr” fault is triggered. The motor coasts to stop.

### ■ o2-07: Motor Direction at Power Up when Using Operator

Determines the direction the motor will rotate after the drive is powered up and the Run command is given from the digital operator.

**Note:** This parameter is effective only when the Run command is set to be given from the digital operator (b1-02, b1-16 = 0).

No.	Name	Setting Range	Default
o2-07	Motor Direction at Power Up when Using Operator	0 or 1	0

#### Setting 0: Forward

#### Setting 1: Reverse

### ◆ o3: Copy Function

These parameters control the digital operator's Copy function. The Copy function lets the user store all parameter settings into the memory of the digital operator, and easily transfer those settings to other drives (requires that the other drives be the same model, capacity, and have the same control mode setting). See [Copy Function Related Displays on page 285](#) for a description of errors and displays.

#### ■ o3-01 Copy Function Selection

Setting o3-01 will instruct the drive to Read, Write, or Verify parameters settings.

No.	Name	Setting Range	Default
o3-01	Copy Function Selection	0 to 3	0

#### 0: Copy Select (no function)

#### 1: INV --> OP READ

All parameters are copied from the drive to the digital operator.

**Note:** The copy protection for the digital operator is enabled by default. To unlock copy protection, set o3-01 = 1.

## 5.10 o: Operator Related Settings

### 2: OP --> INV WRITE

All parameters are copied from the digital operator to the drive.

### 3: OP<-->INV VERIFY

Parameters in the drive are compared with the parameter settings saved on the digital operator to see if they match.

#### ■ o3-02 Copy Allowed Selection

Restricts or allows the use of the Copy function.

No.	Name	Setting Range	Default
o3-02	Copy Allowed Selection	0 or 1	0

0: Disabled

1: Enabled

## ◆ o4: Maintenance Monitor Settings

### ■ o4-01: Cumulative Operation Time Setting

Parameter o4-01 sets the cumulative operation time of the drive. The user can also manually set this parameter to begin keeping track of operation time from some desired value. Total operation time can be viewed in monitor U4-01.

**Note:** The value in o4-01 is set in 10 h units. For example, a setting of 30 will set the cumulative operation time counter to 300 h. 300 h will also be displayed in monitor U4-01.

No.	Name	Setting Range	Default
o4-01	Cumulative Operation Time Setting	0 to 9999 H	0 H

### ■ o4-02: Cumulative Operation Time Selection

Selects the conditions for how the drive keeps track of its total operation time. This time log can be viewed in U4-01.

No.	Name	Setting Range	Default
o4-02	Cumulative Operation Time Selection	0 or 1	0

#### Setting 0: Power on time

The drive logs the time it is connected to a power supply, regardless if the motor is running or not.

#### Setting 1: Run time

The drive logs the time that the output is active. This includes whenever the Run command is active (even if the motor is not rotating) and when there is voltage output.

### ■ o4-03: Cooling Fan Operation Time Setting

Sets the value for how long the cooling fan has been operating. This value can be viewed in monitor U4-03. Parameter o4-03 also sets the base value used for the cooling fan maintenance, which is displayed in U4-04. Be sure to reset this parameter back to 0 if the cooling fan is replaced.

- Note:**
1. The value in o4-03 increases after every 10 hours of use. A setting of 30 will set the cooling fan operation time counter to 300 h. "300" will be displayed in monitor U4-03.
  2. The cooling fan may require maintenance at an earlier date in harsher environments.

No.	Name	Setting Range	Default
o4-03	Cooling Fan Operation Time Setting	0 to 9999 H	0 H

### ■ o4-05: Capacitor Maintenance Setting

Sets value of the maintenance monitor for the DC bus capacitors displayed in U4-05 as a percentage of the total expected performance life. This value should be reset to 0 when the DC bus capacitors have been replaced.

**Note:** The actual maintenance time will depend on the environment where the drive is used.

No.	Name	Setting Range	Default
o4-05	Capacitor Maintenance Setting	0 to 150%	0%

### ■ o4-07: DC Bus Pre-Charge Relay Maintenance Setting

Sets the value of the softcharge bypass relay maintenance time displayed in U4-06 as a percentage of the total expected performance life. This value should be reset to 0 when the bypass relay has been replaced.

**Note:** The actual maintenance time will depend on the environment where the drive is used.

No.	Name	Setting Range	Default
o4-07	DC Bus Pre-charge Relay Maintenance Setting	0 to 150%	0%

### ■ o4-09: IGBT Maintenance Setting

Sets the value of the IGBT maintenance time displayed in U4-07 as a percentage of the total expected performance life. This value should be reset to 0 when the IGBTs have been replaced.

**Note:** The actual maintenance time will depend on the environment where the drive is used.

No.	Name	Setting Range	Default
o4-09	IGBT Maintenance Setting	0 to 150%	0%

### ■ o4-11: U2, U3 Initialization

Resets the fault trace and fault history monitors (U2-□□ and U3-□□). Initializing the drive using A1-03 does not reset these monitors.

No.	Name	Setting Range	Default
o4-11	U2, U3 Initialization	0 or 1	0

#### Setting 0: No action

The drive keeps the record already saved concerning fault trace and fault history.

#### Setting 1: Reset fault data

Resets the data for the U2-□□ and U3-□□ monitors. Setting o4-11 to 1 and pressing the ENTER key erases fault data and returns the display to 0.

### ■ o4-12: kWh Monitor Initialization

The kWh monitors U4-10 and U4-11 are not initialized when power is shut off or the drive is initialized. Use o4-12 to manually reset them.

No.	Name	Setting Range	Default
o4-12	kWh Monitor Initialization	0 or 1	0

#### Setting 0: No Action

The kWh data are kept as they are.

#### Setting 1: Reset kWh Data

Resets the kWh counter. The monitors U4-10 and U4-11 will display “0” after they are initialized. Once o4-12 is set to 1 and the ENTER key is pressed, kWh data is erased and the display returns to 0.

### ■ o4-13: Number of Run Commands Counter Initialization

The Run command counter displayed in U4-02 is not reset when the power is cycled or the drive is initialized. Use o4-13 to reset U4-02.

No.	Name	Setting Range	Default
o4-13	Number of Run Commands Counter Initialization	0 or 1	0

#### Setting 0: No Action

The Run command data are kept as they are.

#### Setting 1: Number of Run Commands Counter

Resets the Run command counter. The monitor U4-02 will show 0. Once o4-13 is set to 1 and the ENTER key is pressed, the counter value is erased and the display returns to 0.

## 5.10 o: Operator Related Settings

---

### ◆ q: DriveWorksEZ Parameters

q1-01 to q6-07 are reserved for use with DriveWorksEZ. Refer to the DriveWorksEZ manual for more information.

---

### ◆ r: DriveWorksEZ Connection Parameters

r1-01 to r1-40 are reserved for use with DriveWorksEZ. Refer to the DriveWorksEZ manual for more information.

---

### ◆ T: Motor Tuning

Auto-Tuning automatically sets and tunes parameters required for optimal motor performance.

*Refer to Auto-Tuning on page 113* for details on Auto-Tuning parameters.

## 5.11 U: Monitor Parameters

Monitor parameters let the user view various aspects of drive performance using the digital operator display. Some monitors can be output from terminals FM and AM by assigning the specific monitor parameter number (U□-□□) to H4-01 and H4-04. [Refer to H4-01, H4-04: Multi-Function Analog Output Terminal FM, AM Monitor Selection on page 205](#) for details on assigning functions to an analog output.

### ◆ U1: Operation Status Monitors

Status monitors display drive status data such as output frequency and output current. Refer to [U1: Operation Status Monitors on page 391](#) for a complete list of U1-□□ monitors and descriptions.

### ◆ U2: Fault Trace

These monitor parameters are used to view the status of various drive aspects when a fault occurs.

This information is helpful for finding out why a fault occurred. Refer to [U2: Fault Trace on page 393](#) for a complete list of U2-□□ monitors and descriptions.

U2-□□ monitors are not reset when the drive is initialized. [Refer to o4-11: U2, U3 Initialization on page 251](#) for instructions on how to reset these monitor values.

### ◆ U3: Fault History

These parameters display faults that have occurred during operation as well as the drive operation time when those faults occurred. Refer to [U3: Fault History on page 394](#) for a complete list of U3-□□ monitors and descriptions.

U3-□□ monitors are not reset when the drive is initialized. [Refer to o4-11: U2, U3 Initialization on page 251](#) for instructions on how to reset these monitor values.

### ◆ U4: Maintenance Monitors

Maintenance monitors show:

- Runtime data of the drive and cooling fans, and number of Run commands issued
- Maintenance data and replacement information for various drive components
- kWh data
- Highest peak current that has occurred and output frequency at the time the peak current occurred
- Motor overload status information
- Detailed information about the present Run command and frequency reference source selection

[Refer to U4: Maintenance Monitors on page 394](#) for a complete list of U4-□□ monitors and descriptions.

### ◆ U5: PI Monitors

These monitors display various aspects of PI control. [Refer to PI Block Diagram on page 147](#) for details on how these monitors display PI data.

[U5: PI Monitors on page 396](#) has a complete list of U5-□□ monitors and descriptions.

### ◆ U6: Operation Status Monitors

Control monitors show:

- Reference data for the output voltage and vector control
- Data on PM motor rotor synchronization, forward phase compensation, and flux positioning
- The offset value added to the frequency reference by the frequency offset function. [Refer to Setting 44, 45, 46: Offset Frequency 1, 2, 3 on page 188.](#)

Refer to [U6: Operation Status Monitors on page 397](#) for a complete list of U6-□□ monitors and descriptions.

### ◆ U8: DriveWorksEZ Monitors

These monitors are reserved for use with DriveWorksEZ.

A complete description of the U8-□□ monitors can be found in the DriveWorksEZ instruction manual.

# Troubleshooting

---

This chapter provides descriptions of the drive faults, alarms, errors, related displays, and guidance for troubleshooting. This chapter can also serve as a reference guide for tuning the drive during a trial run.

<b>6.1 SECTION SAFETY</b> .....	<b>256</b>
<b>6.2 MOTOR PERFORMANCE FINE-TUNING</b> .....	<b>258</b>
<b>6.3 DRIVE ALARMS, FAULTS, AND ERRORS</b> .....	<b>260</b>
<b>6.4 FAULT DETECTION</b> .....	<b>265</b>
<b>6.5 ALARM DETECTION</b> .....	<b>275</b>
<b>6.6 OPERATOR PROGRAMMING ERRORS</b> .....	<b>280</b>
<b>6.7 AUTO-TUNING FAULT DETECTION</b> .....	<b>283</b>
<b>6.8 COPY FUNCTION RELATED DISPLAYS</b> .....	<b>285</b>
<b>6.9 DIAGNOSING AND RESETTING FAULTS</b> .....	<b>287</b>
<b>6.10 TROUBLESHOOTING WITHOUT FAULT DISPLAY</b> .....	<b>289</b>

## 6.1 Section Safety

### DANGER

#### Electrical Shock Hazard

**Do not connect or disconnect wiring while the power is on.**

Failure to comply will result in death or serious injury.

### WARNING

#### Electrical Shock Hazard

**Do not operate equipment with covers removed.**

Failure to comply could result in death or serious injury.

The diagrams in this section may illustrate drives without covers or safety shields to display details. Be sure to reinstall covers or shields before operating the drives and run the drives according to the instructions described in this manual.

**Always ground the motor-side grounding terminal.**

Improper equipment grounding could result in death or serious injury by contacting the motor case.

**Do not touch terminals before the capacitors have fully discharged.**

Failure to comply could result in death or serious injury.

Before wiring terminals, disconnect all power to the equipment. The internal capacitor remains charged even after the drive input power is turned off. After shutting off the power, wait for at least the amount of time specified on the drive before touching any components.

**Do not allow unqualified personnel to perform work on the drive.**

Failure to comply could result in death or serious injury.

Installation, maintenance, inspection and servicing must be performed only by authorized personnel familiar with installation, adjustment and maintenance of AC drives.

**Do not perform work on the drive while wearing loose clothing, jewelry, or without eye protection.**

Failure to comply could result in death or serious injury.

Remove all metal objects such as watches and rings, secure loose clothing and wear eye protection before beginning work on the drive.

**Do not remove covers or touch circuit boards while the power is on.**

Failure to comply could result in death or serious injury.

#### Fire Hazard

**Tighten all terminal screws to the specified tightening torque.**

Loose electrical connections could result in death or serious injury by fire due to overheating of electrical connections.

**Do not use an improper voltage source.**

Failure to comply could result in death or serious injury by fire.

Verify that the rated voltage of the drive matches the voltage of the incoming drive input power before applying power.



**⚠ WARNING****Do not use improper combustible materials.**

Failure to comply could result in death or serious injury by fire.

Attach the drive to metal or other noncombustible material.

**NOTICE****Observe proper electrostatic discharge procedures (ESD) when handling the drive and circuit boards.**

Failure to comply may result in ESD damage to the drive circuitry.

**Never connect or disconnect the motor from the drive while the drive is outputting voltage.**

Improper equipment sequencing could result in damage to the drive.

**Do not use unshielded cable for control wiring.**

Failure to comply may cause electrical interference resulting in poor system performance. Use shielded twisted-pair wires and ground the shield to the ground terminal of the drive.

**Do not allow unqualified personnel to use the product.**

Failure to comply could result in damage to the drive or braking circuit.

Carefully review instruction manual TOBPC72060000 when connecting a dynamic braking option to the drive.

**Do not modify the drive circuitry.**

Failure to comply could result in damage to the drive and will void warranty.

Yaskawa is not responsible for modification of the product made by the user.

**Check all the wiring after installing the drive and connecting other devices to ensure that all connections are correct.**

Failure to comply could result in damage to the drive.

## 6.2 Motor Performance Fine-Tuning

This section offers helpful information for counteracting oscillation, hunting, or other problems that occur while performing a trial run. Refer to the section below that corresponds to the motor control method used.

**Note:** This section describes parameters that are commonly edited and may be set incorrectly. Consult Yaskawa for more information on detailed settings and fine-tuning the drive.

### ◆ Fine-Tuning V/f Control

**Table 6.1 Parameters for Fine-Tuning Performance in V/f**

Problem	Parameter No.	Corrective Action	Default	Suggested Setting
Motor hunting and oscillation at speeds between 10 and 40 Hz	Hunting Prevention Gain (n1-02)	<ul style="list-style-type: none"> <li>If insufficient motor torque relative to the size of the load causes hunting, reduce the setting.</li> <li>When motor hunting and oscillation occur with a light load, increase the setting.</li> <li>Lower this setting if hunting occurs when using a motor with a relatively low inductance, such as a high-frequency motor or a motor with a larger frame size.</li> </ul>	1.00	0.10 to 2.00
<ul style="list-style-type: none"> <li>Motor noise</li> <li>Motor hunting and oscillation at speeds up to 40 Hz</li> </ul>	Carrier Frequency Selection (C6-02)	<ul style="list-style-type: none"> <li>If the motor noise is too loud, increase the carrier frequency.</li> <li>When motor hunting and oscillation occur at speeds up to 40 Hz, lower the carrier frequency.</li> <li>The default setting for the carrier frequency depends on the drive capacity (o2-04).</li> </ul>	1 (2 kHz)	1 to max. setting
<ul style="list-style-type: none"> <li>Poor torque or speed response</li> <li>Motor hunting and oscillation</li> </ul>	Torque Compensation Primary Delay Time (C4-02)	<ul style="list-style-type: none"> <li>If motor torque and speed response are too slow, decrease the setting.</li> <li>If motor hunting and oscillation occur, increase the setting.</li> </ul>	200 ms <1>	100 to 1000 ms
<ul style="list-style-type: none"> <li>Poor motor torque at speeds below 10 Hz</li> <li>Motor hunting and oscillation</li> </ul>	Torque Compensation Gain (C4-01)	<ul style="list-style-type: none"> <li>If motor torque is insufficient at speeds below 10 Hz, increase the setting.</li> <li>If motor hunting and oscillation with a relatively light load, decrease the setting.</li> </ul>	1.00	0.50 to 1.50
<ul style="list-style-type: none"> <li>Poor motor torque at low speeds</li> <li>Motor instability at motor start</li> </ul>	Mid Output Voltage A (E1-08) Minimum Output Voltage (E1-10)	<ul style="list-style-type: none"> <li>If torque is insufficient at speeds below 10 Hz, increase the setting.</li> <li>If motor instability occurs at motor start, decrease the setting.</li> </ul> <p><b>Note:</b> The recommended setting value is for 200 V class drives. Double this value when using a 400 V class drive.</p>	E1-08: 15.0 V E1-10: 9.0 V <2>	Default setting ±5 V

<1> Default setting value is dependent on parameter A1-02, Control Method Selection, and o2-04, Drive Model Selection.

<2> Default settings change when the Control Method is changed (A1-02) or a different V/f pattern is selected using parameter E1-03.

### ◆ Fine-Tuning Open Loop Vector Control for PM Motors

**Table 6.2 Parameters for Fine-Tuning Performance in OLV/PM**

Problem	Parameter No.	Corrective Action	Default	Suggested Setting
Motor performance not as desired	Motor parameters (E1-□□, E5-□□)	<ul style="list-style-type: none"> <li>Check the settings for base and maximum frequency in the E1-□□ parameters</li> <li>Check E5-□□ parameters and make sure all motor data has been set correctly. Be careful not to enter line to line data where single-phase data is required, and vice versa.</li> <li>Perform Auto-Tuning.</li> </ul>	–	–
Poor motor torque and speed response	Load Inertia Ratio (n8-55)	Adjust parameter n8-55 to meet the load inertia ratio of the machine.	0	Close to the actual load inertia ratio
	Speed Feedback Detection Gain (n8-45)	Increase the speed feedback detection gain (n8-45).	0.8	Increase in increments of 0.05
	Torque Compensation (C4-01)	Enable torque compensation. <b>Note:</b> Setting this value too high can cause overcompensation and motor oscillation.	0	1
Oscillation at start or the motor stalls	Pull-In Current during Accel/Decel (n8-51)	Increase the pull-in current set in n8-51	50%	Increase in steps of 5%
	DC Injection Braking Current (b2-02), DC Injection Time at Start (b2-03)	Use DC Injection Braking at start to align the rotor. Be aware that this operation can cause a short reverse rotation at start.	b2-02 = 50% b2-03 = 0.0 s	b2-03 = 0.5 s Increase b2-02 if needed
	Load Inertia Ratio (n8-55)	Increase the load inertia ratio. <b>Note:</b> Setting this value too high can cause overcompensation and motor oscillation.	0	Close to the actual load inertia ratio
Stalling or oscillation occur when load is applied during constant speed	Pull-In Current Compensation Time Constant (n8-47)	Decrease n8-47 if hunting occurs during constant speed	5.0 s	Reduce in increments of 0.2 s
	Pull-In Current (n8-48)	Increase the pull-in current in n8-48.	30%	Increase in increments of 5%
	Load Inertia Ratio (n8-55)	Increase the load inertia ratio.	0	Close to the actual load inertia ratio
Hunting or oscillation occur	Speed feedback Detection Gain (n8-45)	Decrease the speed feedback detection gain in n8-45.	0.8	Increase in increments 0.05
STO fault trips even if the load is not too high	Induced Voltage Constant (E5-09 or E5-24)	<ul style="list-style-type: none"> <li>Check and adjust the induced voltage constant.</li> <li>Check the motor name plate, the data sheet or contact the motor manufacturer for getting data.</li> </ul>	dep. on drive capacity and motor code	Refer to the motor data sheet or the nameplate.

Problem	Parameter No.	Corrective Action	Default	Suggested Setting
Stalling or STO occurs at high speed as the output voltage becomes saturated.	Output Voltage Limit (n8-62)	Set the value of the input voltage to parameter n8-62	200 Vac or 400 Vac	Set equal to input voltage

### ◆ Parameters to Minimize Motor Hunting and Oscillation

In addition to the parameters discussed on page 258, the following parameters indirectly affect motor hunting and oscillation.

**Table 6.3 Parameters that Affect Control Performance in Applications**

Name (Parameter No.)	Application
Dwell Function (b6-01 through b6-04)	Prevents motor speed loss by maintaining the output frequency when working with heavy loads or when there is powerful backlash on the machine side.
Accel/Decel Time (C1-01 through C1-04)	Adjusting accel and decel times will affect the torque presented to the motor during acceleration or deceleration.
S-Curve Characteristics (C2-01 and C2-02)	Prevents shock at the beginning and end of acceleration.
Jump Frequency (d3-01 through d3-04)	Skips over the resonant frequencies of connected machinery.
Analog Filter Time Constant (H3-13)	Prevents fluctuation in the analog input signal due to noise.
Stall Prevention (L3-01 through L3-06, L3-11)	<ul style="list-style-type: none"> <li>Prevents motor speed loss and overvoltage. Used when the load is too heavy and also during sudden acceleration/ deceleration.</li> <li>Adjustment is not normally required because Stall Prevention is enabled as a default. Disable Stall Prevention during deceleration (L3-04 = "0") when using a braking option.</li> </ul>

## 6.3 Drive Alarms, Faults, and Errors

### ◆ Types of Alarms, Faults, and Errors

Check the digital operator for information about possible faults if the drive or motor fails to operate. *Refer to Using the Digital Operator on page 97.*

If problems occur that are not covered in this manual, contact the nearest Yaskawa representative with the following information:

- Drive model
- Software version
- Date of purchase
- Description of the problem

**Table 6.4** contains descriptions of the various types of alarms, faults, and errors that may occur while operating the drive.

Contact Yaskawa in the event of drive failure.

**Table 6.4 Types of Alarms, Faults, and Errors**

Type	Drive Response
<b>Faults</b>	<p>When the drive detects a fault:</p> <ul style="list-style-type: none"> <li>• The digital operator displays text that indicates the specific fault and the ALM indicator LED remains lit until the fault is reset.</li> <li>• The fault interrupts drive output and the motor coasts to a stop.</li> <li>• Some faults allow the user to select how the drive should stop when the fault occurs.</li> <li>• Fault output terminals MA-MC will close, and MB-MC will open.</li> </ul> <p>The drive will remain inoperable until that fault has been cleared. <i>Refer to Fault Reset Methods on page 288.</i></p>
<b>Minor Faults and Alarms</b>	<p>When the drive detects an alarm or a minor fault:</p> <ul style="list-style-type: none"> <li>• The digital operator displays text that indicates the specific alarm or minor fault, and the ALM indicator LED flashes.</li> <li>• The drive generally continues running the motor, although some alarms allow the user to select a stopping method when the alarm occurs.</li> <li>• One of the multi-function contact outputs closes if set to be tripped by a minor fault (H2- □□ = 10), but not by an alarm.</li> <li>• The digital operator displays text indicating a specific alarm and ALM indicator LED flashes.</li> </ul> <p>To reset the a minor fault or alarm, remove whatever is causing the problem.</p>
<b>Operation Errors</b>	<p>When parameter settings conflict with one another or do not match hardware settings (such as with an option card), it results in an operation error. When the drive detects an operation error:</p> <ul style="list-style-type: none"> <li>• The digital operator displays text that indicates the specific error.</li> <li>• Multi-function contact outputs do not operate.</li> </ul> <p>The drive will not operate the motor until the error has been reset. Correct the settings that caused the operation error to clear the error.</p>
<b>Tuning Errors</b>	<p>Tuning errors occur while performing Auto-Tuning. When the drive detects a tuning error:</p> <ul style="list-style-type: none"> <li>• The digital operator displays text indicating the specific error.</li> <li>• Multi-function contact outputs do not operate.</li> <li>• Motor coasts to stop.</li> </ul> <p>Remove the cause of the error and repeat the Auto-Tuning process.</p>
<b>Copy Function Errors</b>	<p>These are the types of errors that can occur when using the optional digital operator or the USB Copy Unit to copy, read, or verify parameter settings.</p> <ul style="list-style-type: none"> <li>• The digital operator displays text indicating the specific error.</li> <li>• Multi-function contact outputs do not operate.</li> </ul> <p>Pressing any key on the operator will clear the fault. Find out what is causing the problem (such as model incompatibility) and try again.</p>

## ◆ Alarm and Error Displays

### ■ Faults

**Table 6.5** gives an overview of possible fault codes. As conditions such as overvoltage can trip both a fault and an alarm, it is important to distinguish between faults and alarms in order to find the right corrective action.

When the drive detects a fault, the ALM indicator LEDs lights and the fault code appears on the display. The drive fault contact MA-MB-MC will be triggered. If the ALM LED blinks and the code appearing on the operator screen is flashes, then an alarm has been detected. See *Minor Faults and Alarms on page 262* for a list of alarm codes.

**Table 6.5 Fault Displays**

Digital Operator Display		Name	Page	Digital Operator Display		Name	Page
boL	boL	Braking Transistor Overload Fault	265	oFA00	oFA00	Option Card Connection Error (CN5-A)	269
bUS	bUS	Option Communication Error	265	oFA01	oFA01	Option Card Fault (CN5-A)	269
CE	CE	MEMOBUS/Modbus Communication Error	265	oFA03 to oFA06	oFA03 to oFA06	Option Card Error (CN5-A)	270
[CPF00, CPF01 <>]	CPF00, CPF01	Control Circuit Error	265	oFA10, oFA11	oFA10, oFA11	Option Card Error (CN5-A)	270
[CPF02]	CPF02	A/D Conversion Error	265	oFA12 to oFA17	oFA12 to oFA17	Option Card Connection Error (CN5-A)	270
[CPF03]	CPF03	Control Board Connection Error	265	oFA30 to oFA43	oFA30 to oFA43	Comm Option Card Connection Error (CN5-A)	270
[CPF06]	CPF06	EEPROM Memory Data Error	266	oFb00	oFb00	Option Card Connection Error (CN5-B)	270
[CPF07, CPF08]	CPF07, CPF08	Terminal Board Connection Error	266	oFc00	oFc00	Option Card Connection Error (CN5-C)	270
[CPF20, CPF21 <>]	CPF20, CPF21	Control Circuit Error	266	oH	oH	Heatsink Overheat	270
[CPF22]	CPF22	Hybrid IC Error	266	oH1	oH1	Heatsink Overheat	270
[CPF23]	CPF23	Control Board Connection Error	266	oH3	oH3	Motor Overheat Alarm (PTC input)	270
[CPF24]	CPF24	Drive Unit Signal Fault	266	oH4	oH4	Motor Overheat Fault (PTC input)	271
[CPF25]	CPF25	Terminal Board not Connected	266	oH5 <>	oH5	Motor Overheat (NTC Input)	271
[CPF26 to CPF35, CPF40 to CPF45 <>]	CPF26 to CPF35, CPF40 to CPF45	Control Circuit Error	266	oL1	oL1	Motor Overload	271
dv7 <>	dv7	Polarity Judge Timeout	266	oL2	oL2	Drive Overload	271
dWFL	dWFL	DriveWorksEZ Fault	266	oL3	oL3	Overtorque Detection 1	271
E5	E5	SI-T3 Watchdog Timer Error	267	oL7	oL7	High Slip Braking oL	272
EF0	EF0	Option Card External Fault	267	oPr	oPr	Operator Connection Fault	272
EF1 to EF8	EF1 to EF8	External Fault (input terminal S1 to S8)	267	ov	ov	Overvoltage	272
Err	Err	EEPROM Write Error	267	PF	PF	Input Phase Loss	272
FAn	FAn	Internal Fan Fault	267	SC <>	SC	IGBT Upper Arm and Lower Arm Short Circuit	273
FbH	FbH	Excessive PI Feedback	267	SEr	SEr	Too Many Speed Search Restarts	273
FbL	FbL	PI Feedback Loss	268	STo	STo	Pull-Out Detection	273
GF	GF	Ground Fault	268	THo <>	THo	Thermistor Disconnect	279
LF	LF	Output Phase Loss	268	UL3	UL3	Undertorque Detection 1	273
				UL6	UL6	Motor Underload	273
				UnbC <>	UnbC	Current Unbalance	273
				Uv1	Uv1	Undervoltage	273

### 6.3 Drive Alarms, Faults, and Errors

Digital Operator Display		Name	Page
LF2	LF2	Current Imbalance	268
LF3 <2>	LF3	Power Unit Output Phase Loss 3	268
nSE	nSE	Node Setup Error	269
oC	oC	Overcurrent	269

Digital Operator Display		Name	Page
Uv2	Uv2	Control Power Supply Undervoltage	274
Uv3	Uv3	Soft Charge Circuit Fault	274
Uv4 <2>	Uv4	Gate Drive Board Undervoltage	274
voF	voF	Output Voltage Detection Fault	274

<1> Displayed as  $[PF00]$  or  $[PF20]$  when occurring at drive power up. When one of the faults occurs after successfully starting the drive, the display will show  $[PF01]$  or  $[PF21]$ .

<2> Occurs in models CIMR-E□4A0930 and 4A1200.

<3> Valid from the drive software version S8001 and later.

#### ■ Minor Faults and Alarms

**Table 6.6** give an overview of possible alarm codes. As conditions such as overvoltage can trip both a fault and alarm, it is important to distinguish between faults and alarms in order to find the right corrective action.

If an alarm is detected, the ALM LED will blink and the alarm code display flashes. The majority of alarms will trigger a digital output programmed for alarm output (H2-□□ = 10). If the ALM LED lights without blinking, this means that a fault has been detected (not an alarm). Information on fault codes can be found in [Faults on page 261](#).

**Table 6.6 Minor Fault and Alarm Displays**

Digital Operator Display		Name	Minor Fault Output (H2-□□ = 10)	Page
AEr	AEr	Station Number Setting Error (CC-Link, CANopen, MECHATROLINK-II)	YES	275
bb	bb	Drive Baseblock	No output	275
bUS	bUS	Option Card Communications Error	YES	275
CALL	CALL	Serial Communication Transmission Error	YES	275
CE	CE	MEMOBUS/Modbus Communication Error	YES	275
CrST	CrST	Cannot Reset	YES	276
dnE	dnE	Drive Disabled	YES	276
dWAL	dWAL	DriveWorksEZ Alarm	YES	266
E5	E5	SI-T3 Watchdog Timer Error	YES	267
EF	EF	Run Command Input Error	YES	276
EF0	EF0	Option Card External Fault	YES	276
EF1 to EF8	EF1 to EF8	External Fault (input terminal S1 to S8)	YES	276
FbH	FbH	Excessive PI Feedback	YES	276
FbL	FbL	PI Feedback Loss	YES	277
Hbb	Hbb	Hardwire Baseblock Signal Input	YES	277
HbbF	HbbF	Hardwire Baseblock Signal Input	YES	277
HCA	HCA	Current Alarm	YES	277
LT-1	LT-1	Cooling Fan Maintenance Time	No output <1>	277
LT-2	LT-2	Capacitor Maintenance Time	No output <1>	277
LT-3	LT-3	Soft Charge Bypass Relay Maintenance Time	No output <1>	277
LT-4	LT-4	IGBT Maintenance Time (50%)	No output <1>	277
oH	oH	Heatsink Overheat	YES	278
oH2	oH2	Drive Overheat Alarm	YES	278
oH3	oH3	Motor Overheat	YES	278
oH5 <2>	oH5	Motor Overheat (NTC Input)	YES	278
oL3	oL3	Overtorque 1	YES	278
ov	ov	Overvoltage	YES	278

Digital Operator Display		Name	Minor Fault Output (H2-□□ = 10)	Page
PASS	PASS	MEMOBUS/Modbus Test Mode Complete	No output	278
SE	SE	MEMOBUS/Modbus Test Mode Fault	YES	279
THo <2>	THo	Thermistor Disconnect	YES	279
TrPC	TrPC	IGBT Maintenance Time (90%)	YES	279
UL3	UL3	Undertorque 1	YES	279
UL6	UL6	Motor Underload	YES	273
Uv	Uv	Undervoltage	YES	279
voF	voF	Output Voltage Detection Fault	YES	279
WrUn	WrUn	Waiting for Run	YES	279

<1> Output when H2-□□ = 2F.

<2> Occurs in models CIMR-E□4A0930 and 4A1200.

## ■ Operation Errors

Table 6.7 Operation Error Displays

Digital Operator Display	Name	Page	Digital Operator Display	Name	Page	
oPE01	oPE01	Drive Unit Setting Error	280	oPE08	Parameter Selection Error	281
oPE02	oPE02	Parameter Setting Range Error	280	oPE09	PI Control Selection Error	281
oPE03	oPE03	Multi-Function Input Setting Error	280	oPE10	V/f Data Setting Error	281
oPE04	oPE04	Terminal Board Mismatch Error	281	oPE11	Carrier Frequency Setting Error	281
oPE05	oPE05	Run Command Selection Error	281	oPE13	Pulse Train Monitor Selection Error	281
oPE07	oPE07	Multi-Function Analog Input Selection Error	281	oPE16	Energy Saving Constants Error	282

## ■ Auto-Tuning Errors

Table 6.8 Auto-Tuning Error Displays

Digital Operator Display	Name	Page	Digital Operator Display	Name	Page	
End1	End1	Excessive V/f Setting	283	Er-03	STOP button Input	283
End3	End3	Rated Current Setting Alarm	283	Er-04	Line-to-Line Resistance Error	284
End4	End4	Adjusted Slip Value Fell Below Lower Limit	283	Er-05	No-Load Current Error	284
End5	End5	Resistance Between Lines Error	283	Er-08	Rated Slip Error	284
End7	End7	No-Load Current Alarm	283	Er-09	Acceleration Error	284
Er-01	Er-01	Motor Data Error	283	Er-11	Motor Speed Error	284
Er-02	Er-02	Alarm	283	Er-12	Current Detection Error	284

## ■ Errors and Displays When Using the Copy Function

Table 6.9 Copy Errors

Digital Operator Display	Name	Page	
CoPy	CoPy	Writing parameter settings (flashing)	285
CPeR	CPeR	Control mode of the drive does not match	285
CPyE	CPyE	Error writing data	285
CSEr	CSEr	Error occurred in the copy function	285
dFPS	dFPS	Drive models do not match.	285
End	End	Task completed	285
iFEr	iFEr	Communication error	285
ndAT	ndAT	Model, voltage class, capacity, and/or control mode differ	285

### 6.3 Drive Alarms, Faults, and Errors

---

Digital Operator Display		Name	Page
<i>rdEr</i>	rdEr	Error reading data	<a href="#">286</a>
<i>rEAd</i>	rEAd	Reading parameter settings (flashing)	<a href="#">286</a>
<i>vAEr</i>	vAEr	Voltage class and/or drive capacity does not match	<a href="#">286</a>
<i>vFyE</i>	vFyE	Parameter settings in the drive and those saved to the copy function are not the same	<a href="#">286</a>
<i>vrFy</i>	vrFy	Comparing parameter settings (flashing)	<a href="#">286</a>



## 6.4 Fault Detection

### ◆ Fault Displays, Causes, and Possible Solutions


Faults are detected for drive protection, and cause the drive to stop. When a fault occurs, the fault output terminal MA-MB-MC is triggered. Faults have to be cleared manually after removing the cause to start running the drive again.

**Table 6.10 Detailed Fault Displays, Causes, and Possible Solutions**

Digital Operator Display		Fault Name
<i>boL</i>	boL	Braking Transistor Overload Fault
Cause		Possible Solution
The wrong braking resistor is installed.		• Select the optimal braking resistor.
Digital Operator Display		Fault Name
<i>bUS</i>	bUS	Option Communication Error
Cause		Possible Solution
No signal received from the PLC.		• Check for faulty wiring.
Faulty communications wiring or a short circuit exists.		• Correct the wiring
A communications data error occurred due to noise.		• Check for disconnected cables and short circuits. Repair as needed.
The option card is damaged.		• Check the various options available to minimize the effects of noise.
The option card is not properly connected to the drive.		• Take steps to counteract noise in the control circuit, main circuit, and ground wiring.
		• Ensure that other equipment such as switches or relays do not cause noise. Use surge suppressors if necessary.
		• Use only recommended cables or other shielded line. Ground the shield on the controller side or on the drive input power side.
		• Separate all communication wiring from drive power lines. Install an EMC noise filter to the drive power supply input.
		• Replace the option card if there are no problems with the wiring and the error continues to occur.
		• The connector pins on the option card are not properly lined up with the connector pins on the drive.
		• Reinstall the option card.
Digital Operator Display		Fault Name
<i>CE</i>	CE	MEMOBUS/Modbus Communication Error
Cause		Possible Solution
Faulty communications wiring or a short circuit exists.		• Check for faulty wiring.
Communication data error occurred due to noise.		• Correct the wiring
		• Check for disconnected cables and short circuits. Repair as needed.
		• Check the various options available to minimize the effects of noise.
		• Take steps to counteract noise in the control circuit, main circuit, and ground wiring.
		• Use only recommended cables or other shielded line. Ground the shield on the controller side or on the drive input power side.
		• Ensure that other equipment such as switches or relays do not cause noise and use surge suppressors if required.
		• Separate all communication wiring from drive power lines. Install an EMC noise filter to the drive power supply input.
Digital Operator Display		Fault Name
<i>CPF00 or CPF01</i> </>	CPF00 or CPF01 </>	Control Circuit Error
Cause		Possible Solution
There is a self diagnostic error in control circuit.		• Cycle power to the drive.
Connector on the operator is damaged.		• If the problem continues, replace either the control board or the entire drive. For instructions on replacing the control board, contact Yaskawa or your nearest sales representative.
		• Replace the operator.
Digital Operator Display		Fault Name
<i>CPF02</i>	CPF02	A/D Conversion Error
Cause		Possible Solution
Control circuit is damaged.		• An A/D conversion error or control circuit error occurred.
		• Cycle power to the drive.
		• If the problem continues, replace either the control board or the entire drive. For instructions on replacing the control board, contact Yaskawa or your nearest sales representative.
Digital Operator Display		Fault Name
<i>CPF03</i>	CPF03	Control Board Connection Error
Cause		Possible Solution
There is a connection error.		• Connection error between the control board and the drive
		• Turn the power off and check the connection between the control board and the drive.
		• If the problem continues, replace either the control board or the entire drive.
Drive fails to operate properly due to noise interference.		• Check the various options available to minimize the effects of noise.
		• Take steps to counteract noise in the control circuit, main circuit, and ground wiring.
		• Use only recommended cables or other shielded line. Ground the shield on the controller side or on the drive input power side.
		• Ensure that other equipment such as switches or relays do not cause noise and use surge suppressors if required.
		• Separate all communication wiring from drive power lines. Install an EMC noise filter to the drive power supply input.

## 6.4 Fault Detection

Digital Operator Display		Fault Name
<code>CPF06</code>	CPF06	EEPROM Memory Data Error There is an error in the data saved to EEPROM.
<b>Cause</b>		<b>Possible Solution</b>
There is an error in EEPROM control circuit.		<ul style="list-style-type: none"> <li>Turn the power off and check the connection between the control board and the drive.</li> <li>If the problem continues, replace either the control board or the entire drive. For instructions on replacing the control board, contact Yaskawa or your nearest sales representative.</li> </ul>
The power supply was switched off when parameters were being saved to the drive.		Reinitialize the drive (A1-03).
Digital Operator Display		Fault Name
<code>CPF07</code>	CPF07	Terminal Board Connection Error
<code>CPF08</code>	CPF08	
<b>Cause</b>		<b>Possible Solution</b>
There is a fault connection between the terminal board and control board.		<ul style="list-style-type: none"> <li>Turn the power off and reconnect the control circuit terminal board.</li> <li>If the problem continues, replace either the control board or the entire drive. For instructions on replacing the control board, contact Yaskawa or your nearest sales representative.</li> </ul>
Digital Operator Display		Fault Name
<code>CPF20</code> or <code>CPF21 &lt;I&gt;</code>	CPF20 or CPF21 <I>	Control Circuit Error
<b>Cause</b>		<b>Possible Solution</b>
Hardware is damaged.		<ul style="list-style-type: none"> <li>Cycle power to the drive.</li> <li>If the problem continues, replace either the control board or the entire drive. For instructions on replacing the control board, contact Yaskawa or your nearest sales representative.</li> </ul>
Digital Operator Display		Fault Name
<code>CPF22</code>	CPF22	Hybrid IC Error
<b>Cause</b>		<b>Possible Solution</b>
Hybrid IC on the main circuit is damaged.		<ul style="list-style-type: none"> <li>Cycle power to the drive. <i>Refer to Diagnosing and Resetting Faults on page 287.</i></li> <li>If the problem continues, replace either the control board or the entire drive. For instructions on replacing the control board, contact Yaskawa or your nearest sales representative.</li> </ul>
Digital Operator Display		Fault Name
<code>CPF23</code>	CPF23	Control Board Connection Error Connection error between the control board and the drive
<b>Cause</b>		<b>Possible Solution</b>
Hardware is damaged.		<ul style="list-style-type: none"> <li>Turn the power off and check the connection between the control board and the drive.</li> <li>If the problem continues, replace either the control board or the entire drive. For instructions on replacing the control board, contact Yaskawa or your nearest sales representative.</li> </ul>
Digital Operator Display		Fault Name
<code>CPF24</code>	CPF24	Drive Unit Signal Fault The drive capacity cannot be detected correctly (drive capacity is checked when the drive is powered up).
<b>Cause</b>		<b>Possible Solution</b>
Hardware is damaged.		Replace either the control board or the entire drive. For instructions on replacing the control board, contact Yaskawa or your nearest sales representative.
Digital Operator Display		Fault Name
<code>CPF25</code>	CPF25	Terminal Board not Connected
<b>Cause</b>		<b>Possible Solution</b>
Terminal board is not connected correctly.		Reconnect the terminal board to the connector on the drive, then cycle the power to the drive.
Digital Operator Display		Fault Name
<code>CPF26 to CPF35</code> <code>CPF40 to CPF45 &lt;D&gt;</code>	CPF26 to CPF35, CPF40 to CPF45	Control Circuit Error CPU error
<b>Cause</b>		<b>Possible Solution</b>
Hardware is damaged.		Replace either the control board or the entire drive. For instructions on replacing the control board, contact Yaskawa or your nearest sales representative.
Digital Operator Display		Fault Name
<code>dv7 &lt;D&gt;</code>	dv7	Polarity Judge Timeout
<b>Cause</b>		<b>Possible Solution</b>
Disconnection in the motor coil winding. Loose output terminals.		<ul style="list-style-type: none"> <li>Measure the motor line-to-line resistance and replace the motor if the motor coil winding is disconnected.</li> <li>Check for loose terminals. Apply the tightening torque specified in this manual to fasten the terminals.</li> </ul> Refer to <i>Wire Size and Torque Specifications on page 82</i> .
Digital Operator Display		Fault Name
<code>dWAL</code>	dWAL	DriveWorksEZ Fault
<code>dWFL</code>	dWFL	
<b>Cause</b>		<b>Possible Solution</b>
Fault output by DriveWorksEZ		<ul style="list-style-type: none"> <li>Correct whatever caused the fault.</li> </ul>

Digital Operator Display		Fault Name
E5	E5	SI-T3 Watchdog Timer Error
		The watchdog has timed out.
Cause		Possible Solution
Data has not been received from the PLC, triggering the watchdog timer.		⇒ Execute DISCONNECT or ALM_CLR, then issue a CONNECT command or SYNC_SET command and proceed to phase 3.
Digital Operator Display		Fault Name
EF0	EF0	Option Card External Fault
		An external fault condition is present.
Cause		Possible Solution
An external fault was received from the PLC with other than F6-03 = 3 “alarm only” (the drive continued to run after external fault).		<ul style="list-style-type: none"> <li>Remove the cause of the external fault.</li> <li>Remove the external fault input from the PLC.</li> </ul>
Problem with the PLC program.		Check the PLC program and correct problems.
Digital Operator Display		Fault Name
EF1	EF1	External Fault (input terminal S1)
		External fault at multi-function input terminal S1.
EF2	EF2	External Fault (input terminal S2)
		External fault at multi-function input terminal S2.
EF3	EF3	External Fault (input terminal S3)
		External fault at multi-function input terminal S3.
EF4	EF4	External Fault (input terminal S4)
		External fault at multi-function input terminal S4.
EF5	EF5	External Fault (input terminal S5)
		External fault at multi-function input terminal S5.
EF6	EF6	External Fault (input terminal S6)
		External fault at multi-function input terminal S6.
EF7	EF7	External Fault (input terminal S7)
		External fault at multi-function input terminal S7.
EF8	EF8	External Fault (input terminal S8)
		External fault at multi-function input terminal S8.
Cause		Possible Solution
An external device has tripped an alarm function.		Remove the cause of the external fault and reset the fault.
Wiring is incorrect.		<ul style="list-style-type: none"> <li>Ensure the signal lines have been connected properly to the terminals assigned for external fault detection (H1-□□ = 20 to 2F).</li> <li>Reconnect the signal line.</li> </ul>
Incorrect setting of multi-function contact inputs.		<ul style="list-style-type: none"> <li>Check if the any unused terminals are set for H1-□□ = 20 to 2F (External Fault).</li> <li>Change the terminal settings.</li> </ul>
Digital Operator Display		Fault Name
Err	Err	EEPROM Write Error
		Data cannot be written to the EEPROM.
Cause		Possible Solution
Noise has corrupted data while writing to the EEPROM.		<ul style="list-style-type: none"> <li>Press the  button.</li> <li>Correct the parameter setting.</li> <li>Cycle power to the drive. <a href="#">Refer to Diagnosing and Resetting Faults on page 287.</a></li> <li>Replace either the control board or the entire drive. For instructions on replacing the control board, contact Yaskawa or your nearest sales representative.</li> </ul>
Hardware problem.		<ul style="list-style-type: none"> <li>Replace either the control board or the entire drive. For instructions on replacing the control board, contact Yaskawa or your nearest sales representative.</li> </ul>
Digital Operator Display		Fault Name
FAn	FAn	Internal Fan Fault
		Fan or magnetic contactor failed.
Cause		Possible Solution
Internal cooling fan has malfunctioned (models 2A0360, 2A0415, 4A0362 to 4A1200).		<p>Cycle power to the drive and see if the fault is still present. Check if the fan is operating or not. Verify the cumulative operation time of the fan using monitor U4-03, and the fan maintenance timer in U4-04. If the cooling fan has passed its expected performance life or is damaged in some way, follow the instructions in this manual to replace it.</p>
Fault detected in the internal cooling fan or magnetic contactor to the power supply (models 2A0250 to 2A0415, 4A0165 to 4A1200).		<p>Cycle power to the drive and see if the fault is still present. If the fault still occurs, either replace the control circuit board or the entire unit. For instructions on replacing the power board, contact the Yaskawa sales office directly or your nearest Yaskawa representative.</p>
Digital Operator Display		Fault Name
FbH	FbH	Excessive PI Feedback
		PI feedback input is greater than the level set b5-36 for longer than the time set to b5-37. To enable fault detection, set b5-12 = 2 or 5.
Cause		Possible Solution
Parameters are not set appropriately.		Check the settings of parameters b5-36 and b5-37.
Wiring for PI feedback is incorrect.		Correct the wiring.
There is a problem with the feedback sensor.		<ul style="list-style-type: none"> <li>Check the sensor on the control side.</li> <li>Replace the sensor if damaged.</li> </ul>

## 6.4 Fault Detection

Digital Operator Display		Fault Name
FbL	FbL	PI Feedback Loss
		This fault occurs when PI feedback loss detection is programmed to trigger a fault (b5-12 = 2) and the PI feedback level is below the detection level set to b5-13 for longer than the time set to b5-14.
<b>Cause</b>		<b>Possible Solution</b>
Parameters are not set appropriately.		Check the settings of parameters b5-13 and b5-14.
Wiring for PI feedback is incorrect.		Correct the wiring.
There is a problem with the feedback sensor.		Check the sensor on the controller side. If damaged, replace the sensor.
Digital Operator Display		Fault Name
GF	GF	Ground Fault
		<ul style="list-style-type: none"> <li>A current short to ground exceeded 50% of rated current on the output side of the drive.</li> <li>Setting L8-09 to 1 enables ground fault detection.</li> </ul>
<b>Cause</b>		<b>Possible Solution</b>
Motor insulation is damaged.		<ul style="list-style-type: none"> <li>Check the insulation resistance of the motor.</li> <li>Replace the motor.</li> </ul>
A damaged motor cable is creating a short circuit.		<ul style="list-style-type: none"> <li>Check the motor cable.</li> <li>Remove the short circuit and turn the power back on.</li> </ul>
The leakage current at the drive output is too high.		<ul style="list-style-type: none"> <li>Check the resistance between the cable and the ground terminal (⊕).</li> <li>Replace the cable.</li> </ul>
The drive started to run during a current offset fault or while coasting to a stop.		<ul style="list-style-type: none"> <li>Reduce the carrier frequency.</li> <li>Reduce the amount of stray capacitance.</li> </ul>
Hardware problem.		<ul style="list-style-type: none"> <li>The value set exceeds the allowable setting range while the drive automatically adjusts the current offset (this happens only when attempting to restart a PM motor that is coasting to stop).</li> <li>Enable Speed Search at start (b3-01 = 1).</li> <li>Perform Speed Search 1 or 2 (H1-□□ = 61 or 62) via one of the external terminals.</li> </ul> <p><b>Note:</b> Speed Search 1 and 2 are the same when using PM OLV.</p>
Digital Operator Display		Fault Name
LF	LF	Output Phase Loss
		<ul style="list-style-type: none"> <li>Phase loss on the output side of the drive.</li> <li>Phase Loss Detection is enabled when L8-07 is set to 1 or 2.</li> </ul>
<b>Cause</b>		<b>Possible Solution</b>
The output cable is disconnected.		<ul style="list-style-type: none"> <li>Check for wiring errors and ensure the output cable is connected properly.</li> <li>Correct the wiring.</li> </ul>
The motor winding is damaged.		<ul style="list-style-type: none"> <li>Check the resistance between motor lines.</li> <li>Replace the motor if the winding is damaged.</li> </ul>
The output terminal is loose.		<ul style="list-style-type: none"> <li>Apply the tightening torque specified in this manual to fasten the terminals. <i>Refer to Wire Size and Torque Specifications on page 82.</i></li> </ul>
The rated current of the motor being used is less than 5% of the drive rated current.		Check the drive and motor capacities.
An output transistor is damaged.		Replace either the control board or the entire drive. For instructions on replacing the control board, contact Yaskawa or your nearest sales representative.
A single-phase motor is being used.		The drive cannot operate a single phase motor.
Digital Operator Display		Fault Name
LF2	LF2	Output current imbalance (detected when L8-29 = 1)
		One or more of the phases in the output current is lost.
<b>Cause</b>		<b>Possible Solution</b>
Phase loss has occurred on the output side of the drive.		<ul style="list-style-type: none"> <li>Check for faulty wiring or poor connections on the output side of the drive.</li> <li>Correct the wiring.</li> </ul>
Terminal wires on the output side of the drive are loose.		Apply the tightening torque specified in this manual to fasten the terminals. <i>Refer to Wire Size and Torque Specifications on page 82.</i>
The output circuit is damaged.		Replace either the control board or the entire drive. For instructions on replacing the control board, contact Yaskawa or your nearest sales representative.
Motor impedance or motor phases are uneven.		<ul style="list-style-type: none"> <li>Measure the line-to-line resistance for each motor phase. Ensure all values are the same.</li> <li>Replace the motor.</li> </ul>
Digital Operator Display		Fault Name
LF3	LF3	Power Unit Output Phase Loss 3
		Phase loss occurred on the output side (L8-78 is enabled).
<b>Cause</b>		<b>Possible Solution</b>
The gate drive board in the power unit is damaged.		Cycle the power supply. Refer to <i>Diagnosing and Resetting Faults on page 287</i> for instructions. If the fault continues to occur, replace the gate drive board or the drive.
The current detection circuit in the power unit is damaged.		Check for any incorrect wiring.
Cable to the current detection circuit in the power unit is not connected properly.		Correct any wiring mistakes.
Cable between the output reactor and the power unit is not connected.		Contact Yaskawa or your nearest sales representative for instructions.
Cable between the output reactor and the power unit is loose.		

Digital Operator Display		Fault Name
	nSE	Node Setup Error A terminal assigned to the node setup function closed during run.
<b>Cause</b>		<b>Possible Solution</b>
The node setup terminal closed during run. A run command was issued while the node setup function was active.		Stop the drive when using the node setup function.
Digital Operator Display		Fault Name
	oC	Overcurrent Drive sensors have detected an output current greater than the specified overcurrent level.
<b>Cause</b>		<b>Possible Solution</b>
The motor has been damaged due to overheating or the motor insulation is damaged.		<ul style="list-style-type: none"> <li>Check the insulation resistance.</li> <li>Replace the motor.</li> </ul>
One of the motor cables has shorted out or there is a grounding problem.		<ul style="list-style-type: none"> <li>Check the motor cables.</li> <li>Remove the short circuit and power the drive back up.</li> </ul>
The load is too heavy.		<ul style="list-style-type: none"> <li>Check the resistance between the motor cables and the ground terminal <math>\oplus</math>.</li> <li>Replace damaged cables.</li> </ul>
The acceleration or deceleration times are too short.		<ul style="list-style-type: none"> <li>Measure the current flowing into the motor.</li> <li>Replace the drive with a larger capacity unit if the current value exceeds the rated current of the drive.</li> <li>Determine if there is sudden fluctuation in the current level.</li> <li>Reduce the load to avoid sudden changes in the current level or switch to a larger drive.</li> </ul>
The drive is attempting to operate a specialized motor or a motor larger than the maximum size allowed.		<ul style="list-style-type: none"> <li>Calculate the torque needed during acceleration relative to the load inertia and the specified acceleration time. If the right amount of torque cannot be set, make the following changes: <ul style="list-style-type: none"> <li>Increase the acceleration time (C1-01, -03, -05, -07)</li> <li>Increase the S-curve characteristics (C2-01 and C2-02)</li> <li>Increase the capacity of the drive.</li> </ul> </li> <li>Check the motor capacity.</li> <li>Ensure that the rated capacity of the drive is greater than or equal to the capacity rating found on the motor nameplate.</li> </ul>
Magnetic contactor (MC) on the output side of the drive has turned on or off.		Set up the operation sequence so that the MC is not tripped while the drive is outputting current.
V/f setting is not operating as expected.		<ul style="list-style-type: none"> <li>Check the ratios between the voltage and frequency.</li> <li>Set parameter E1-04 through E1-10 appropriately.</li> <li>Lower the voltage if it is too high relative to the frequency.</li> </ul>
Excessive torque compensation.		<ul style="list-style-type: none"> <li>Check the amount of torque compensation.</li> <li>Reduce the torque compensation gain (C4-01) until there is no speed loss and less current.</li> </ul>
Drive fails to operate properly due to noise interference.		<ul style="list-style-type: none"> <li>Review the possible solutions provided for handling noise interference.</li> <li>Review the section on handling noise interference and check the control circuit lines, main circuit lines, and ground wiring.</li> </ul>
Overexcitation gain is set too high.		<ul style="list-style-type: none"> <li>Check if fault occurs simultaneously to overexcitation function operation.</li> <li>Consider motor flux saturation and reduce the value of n3-13 (Overexcitation Deceleration Gain).</li> </ul>
Run command applied while motor was coasting.		<ul style="list-style-type: none"> <li>Enable Speed Search at start (b3-01 = 1).</li> <li>Program the Speed Search command input through one of the multi-function contact input terminals (H1-□□ = 61 or 62).</li> </ul>
The wrong motor code has been entered for PM Open Loop Vector (Yaskawa motors only) or the motor data are wrong.		<ul style="list-style-type: none"> <li>Enter the correct motor code to E5-01.</li> <li>If a non-Yaskawa PM motor is used, enter "FFFF" to E5-01. Set the correct motor data to the E5-□□ parameters or perform Auto-Tuning.</li> </ul>
The motor control method and motor do not match.		<ul style="list-style-type: none"> <li>Check which motor control method the drive is set to (A1-02).</li> <li>For IM motors, set A1-02 = "0".</li> <li>For PM motors, set A1-02 = "5".</li> </ul>
The drives rated output current is too small.		Use a larger drive.
Digital Operator Display		Fault Name
	oFA00	Option Card Connection Error at Option Port CN5-A Option compatibility error
<b>Cause</b>		<b>Possible Solution</b>
The option card installed into port CN5-A is incompatible with the drive.		Check if the drive supports the option card that you are attempting to install. The port CN5-A supports communication option cards only. More than one comm. option cannot be installed. The following option cards are not available for this drive: PG-X3, PG-B3, DI-A3, AI-A3, DO-A3, AO-A3
Digital Operator Display		Fault Name
	oFA01	Option Card Fault at Option Port CN5-A Option not properly connected
<b>Cause</b>		<b>Possible Solution</b>
The option board connection to port CN5-A is faulty.		<ul style="list-style-type: none"> <li>Turn the power off and reconnect the option card.</li> <li>Check if the option card is properly plugged into the option port. Make sure the card is fixed properly.</li> <li>If the option is not a communication option card, try to use the card in another option port. If it works there, replace the drive. If the error persists (oFb01 or oFC01 occur), replace the option board.</li> </ul>

## 6.4 Fault Detection

Digital Operator Display		Fault Name
oFA03 to oFA06	oFA03 to oFA06	Option card error occurred at option connector CN5-A
oFA10, oFA11	oFA10, oFA11	
oFA12 to oFA17	oFA12 to oFA17	Option Card Connection Error (CN5-A)
oFA30 to oFA43	oFA30 to oFA43	Comm Option Card Connection Error (CN5-A)
Cause		Possible Solution
Option card or hardware is damaged.		<ul style="list-style-type: none"> <li>• Cycle power to the drive.</li> <li>• If the problem continues, replace either the control board or the entire drive. For instructions on replacing the control board, contact Yaskawa or your nearest sales representative.</li> </ul>
Digital Operator Display		Fault Name
oFb00	oFb00	Option Card Fault at Option Port CN5-B
		Option compatibility error
Cause		Possible Solution
The option card installed into port CN5-B is incompatible with the drive.		Check if the drive supports the option card that you are attempting to install. The following option cards are not available for this drive: PG-X3, PG-B3, DI-A3, AI-A3, DO-A3, AO-A3
A communication option card has been installed in option port CN5-B.		Communication option cards are supported by option port CN5-A only. More than one comm. option cannot be installed.
Digital Operator Display		Fault Name
oFc00	oFc00	Option Card Connection Error at Option Port CN5-C
		Option compatibility error
Cause		Possible Solution
The option card installed into port CN5-C is incompatible with the drive.		Check if the drive supports the option card that you are attempting to instal. The following option cards are not available for this drive: PG-X3, PG-B3, DI-A3, AI-A3, DO-A3, AO-A3
A communication option card has been installed in option port CN5-C.		Communication option cards are supported by option port CN5-A only. More than one comm. option cannot be installed.
Digital Operator Display		Fault Name
oH	oH	Heatsink Overheat
		The temperature of the heatsink exceeded the overheat pre-alarm level set to L8-02. Default value for L8-02 is determined by drive capacity (o2-04).
Cause		Possible Solution
Surrounding temperature is too high.		<ul style="list-style-type: none"> <li>• Check the temperature surrounding the drive. Verify temperature is within drive specifications.</li> <li>• Improve the air circulation within the enclosure panel.</li> <li>• Install a fan or air conditioner to cool the surrounding area.</li> <li>• Remove anything near the drive that might be producing excessive heat.</li> </ul>
Load is too heavy.		<ul style="list-style-type: none"> <li>• Measure the output current.</li> <li>• Decrease the load.</li> <li>• Lower the carrier frequency (C6-02).</li> </ul>
Internal cooling fan is stopped.		<ul style="list-style-type: none"> <li>• Replace the cooling fan. <i>Refer to Cooling Fan Component Names on page 303.</i></li> <li>• After replacing the drive, reset the cooling fan maintenance parameter (o4-03 = 0).</li> </ul>
Digital Operator Display		Fault Name
oH1	oH1	Overheat 1 (Heatsink Overheat)
		The temperature of the heatsink exceeded the drive overheat level. The overheat level is determined by drive capacity (o2-04).
Cause		Possible Solution
Surrounding temperature is too high.		<ul style="list-style-type: none"> <li>• Check the temperature surrounding the drive.</li> <li>• Improve the air circulation within the enclosure panel.</li> <li>• Install a fan or air conditioner to cool the surrounding area.</li> <li>• Remove anything near the drive that might be producing excessive heat.</li> </ul>
Load is too heavy.		<ul style="list-style-type: none"> <li>• Measure the output current.</li> <li>• Lower the carrier frequency (C6-02).</li> <li>• Reduce the load.</li> </ul>
Digital Operator Display		Fault Name
oH3	oH3	Motor Overheat Alarm (PTC Input)
		<ul style="list-style-type: none"> <li>• The motor overheat signal to analog input terminal A1, A2, or A3 exceeded the alarm detection level.</li> <li>• Detection requires multi-function analog input H3-02, H3-06, or H3-10 be set to "E".</li> </ul>
Cause		Possible Solution
Motor has overheated		<ul style="list-style-type: none"> <li>• Check the size of the load, the accel/decel times, and the cycle times.</li> <li>• Decrease the load.</li> <li>• Increase the acceleration and deceleration times (C1-01 through C1-04).</li> <li>• Adjust the preset V/f pattern (E1-04 through E1-10). This will mainly involve reducing E1-08 and E1-10.</li> <li>• Be careful not to lower E1-08 and E1-10 too much, as this reduces load tolerance at low speeds.</li> <li>• Check the motor rated current.</li> <li>• Enter the motor rated current as indicated on the motor nameplate (E2-01).</li> <li>• Ensure the motor cooling system is operating normally.</li> <li>• Repair or replace the motor cooling system.</li> </ul>

Digital Operator Display		Fault Name
oH4	oH4	Motor Overheat Fault (PTC Input)
		<ul style="list-style-type: none"> <li>The motor overheat signal to analog input terminal A1, A2, or A3 exceeded the fault detection level.</li> <li>Detection requires that multi-function analog input H3-02, H3-06, or H3-10 = "E".</li> </ul>
Cause		Possible Solution
Motor has overheated.		<ul style="list-style-type: none"> <li>Check the size of the load, the accel/decel times, and the cycle times.</li> <li>Decrease the load.</li> <li>Increase the acceleration and deceleration times (C1-01 through C1-04).</li> </ul>
		<ul style="list-style-type: none"> <li>Adjust the preset V/f pattern (E1-04 through E1-10). This will mainly involve reducing E1-08 and E1-10. Be careful not to lower E1-08 and E1-10 too much because this reduces load tolerance at low speeds.</li> </ul>
		<ul style="list-style-type: none"> <li>Check the motor rated current.</li> <li>Enter the motor rated current as indicated on the motor nameplate (E2-01).</li> <li>Ensure the motor cooling system is operating normally.</li> <li>Repair or replace the motor cooling system.</li> </ul>
Digital Operator Display		Fault Name
oH5	oH5	Motor Overheat (NTC Input)
		The motor temperature exceeded the level set in L1-16.
Cause		Possible Solution
Motor has overheated.		<ul style="list-style-type: none"> <li>Reduce the load.</li> <li>Check the ambient temperature.</li> </ul>
Digital Operator Display		Fault Name
oL1	oL1	Motor Overload
		The electronic motor overload protection tripped.
Cause		Possible Solution
Load is too heavy.		Reduce the load.
Cycle times are too short during acceleration and deceleration.		Increase the acceleration and deceleration times (C1-01 through C1-04).
A general purpose motor is driven below the rated speed with too high load.		<ul style="list-style-type: none"> <li>Reduce the load.</li> <li>Increase the speed.</li> <li>If the motor is supposed to operate at low speeds, either increase the motor capacity or use a motor specifically designed to operate in the desired speed range.</li> </ul>
The output voltage is too high.		Adjust the user-set V/f patterns (E1-04 through E1-10). Parameters E1-08 and E1-10 may need to be reduced. Be careful not to lower E1-08 and E1-10 too much because this reduces load tolerance at low speeds.
The wrong motor rated current is set to E2-01.		<ul style="list-style-type: none"> <li>Check the motor-rated current.</li> <li>Enter the value written on the motor nameplate to parameter E2-01.</li> </ul>
The maximum output frequency is set incorrectly.		<ul style="list-style-type: none"> <li>Check the rated frequency indicated on the motor nameplate.</li> <li>Enter the rated frequency to E1-06 (Base Frequency).</li> </ul>
Multiple motors are running off the same drive.		Disable the motor protection function (L1-01 = 0) and install a thermal relay to each motor.
The electrical thermal protection characteristics and motor overload characteristics do not match.		<ul style="list-style-type: none"> <li>Check the motor characteristics.</li> <li>Correct the type of motor protection that has been selected (L1-01).</li> <li>Install an external thermal relay.</li> </ul>
The electrical thermal relay is operating at the wrong level.		<ul style="list-style-type: none"> <li>Check the current rating listed on the motor nameplate.</li> <li>Check the value set for the motor rated current (E2-01).</li> </ul>
Motor overheated by overexcitation operation.		<ul style="list-style-type: none"> <li>Overexcitation increases the motor losses and the motor temperature. If applied too long, motor damage can occur. Prevent excessive overexcitation operation or apply proper cooling to the motor.</li> <li>Reduce the excitation deceleration gain (n3-13).</li> <li>Set L3-04 (Stall Prevention during Deceleration) to a value other than 4.</li> </ul>
Speed Search related parameters are set incorrectly.		<ul style="list-style-type: none"> <li>Check values set to Speed Search related parameters.</li> <li>Adjust the Speed Search current and Speed Search deceleration times (b3-02 and b3-03 respectively).</li> <li>After Auto-Tuning, enable Speed Estimation Speed Search (b3-24 = 1).</li> </ul>
Output current fluctuation due to input phase loss		Check the power supply for phase loss.
Digital Operator Display		Fault Name
oL2	oL2	Drive Overload
		The thermal sensor of the drive triggered overload protection.
Cause		Possible Solution
Load is too heavy.		Reduce the load.
Acceleration or deceleration times are too short.		Increase the settings for the acceleration and deceleration times (C1-01 through C1-04).
The output voltage is too high.		<ul style="list-style-type: none"> <li>Adjust the preset V/f pattern (E1-04 through E1-10). This will mainly involve reducing E1-08 and E1-10.</li> <li>Be careful not to lower E1-08 and E1-10 excessively because this reduces load tolerance at low speeds.</li> </ul>
Drive capacity is too small.		Replace the drive with a larger model.
Overload occurred when operating at low speeds.		<ul style="list-style-type: none"> <li>Reduce the load when operating at low speeds.</li> <li>Replace the drive with a model that is one frame size larger.</li> <li>Lower the carrier frequency (C6-02).</li> </ul>
Excessive torque compensation.		Reduce the torque compensation gain (C4-01) until there is no speed loss but less current.
Speed Search related parameters are set incorrectly.		<ul style="list-style-type: none"> <li>Check the settings for all Speed Search related parameters.</li> <li>Adjust the current used during Speed Search and the Speed Search deceleration time (b3-03 and b3-02 respectively).</li> <li>After Auto-Tuning the drive, enable the Speed Estimation Speed Search (b3-24 = 1).</li> </ul>
Output current fluctuation due to input phase loss		Check the power supply for phase loss.
Digital Operator Display		Fault Name
oL3	oL3	Overtorque Detection 1
		The current has exceeded the value set for torque detection (L6-02) for longer than the allowable time (L6-03).
Cause		Possible Solution
Parameter settings are not appropriate for the load.		Check the settings of parameters L6-02 and L6-03.
Fault on the machine side (e.g., machine is locked up).		Check the status of the load. Remove the cause of the fault.

## 6.4 Fault Detection

Digital Operator Display		Fault Name
oL7	oL7	High Slip Braking oL
		The output frequency stayed constant for longer than the time set in n3-04 during High Slip Braking.
Cause		Possible Solution
Excessive load inertia.		<ul style="list-style-type: none"> <li>Reduce deceleration times in parameters C1-02, C1-04, for applications that do not use High Slip Braking.</li> <li>Use dynamic braking options to shorten deceleration time.</li> </ul>
Motor is driven by the load.		
Something on the load side is restricting deceleration.		
The overload time during High Slip Braking is too short.		<ul style="list-style-type: none"> <li>Increase parameter n3-04 (High-slip Braking Overload Time).</li> <li>Install a thermal relay and increase the setting of n3-04 to the maximum value.</li> </ul>
Digital Operator Display		Fault Name
oPr	oPr	External Digital Operator Connection Fault
		<ul style="list-style-type: none"> <li>The external operator has been disconnected from the drive.</li> <li><b>Note:</b> An oPr fault will occur when all of the following conditions are true: <ul style="list-style-type: none"> <li>Output is interrupted when the operator is disconnected (o2-06 = 1).</li> <li>The Run command is assigned to the operator (b1-02 = 0 and LOCAL has been selected).</li> </ul> </li> </ul>
Cause		Possible Solution
External operator is not properly connected to the drive.		<ul style="list-style-type: none"> <li>Check the connection between the operator and the drive.</li> <li>Replace the cable if damaged.</li> <li>Turn off the drive input power and disconnect the operator. Next reconnect the operator and turn the drive input power back on.</li> </ul>
Digital Operator Display		Fault Name
ov	ov	Overvoltage
		Voltage in the DC bus has exceeded the overvoltage detection level. <ul style="list-style-type: none"> <li>For 200 V class: approximately 410 V</li> <li>For 400 V class: approximately 820 V</li> </ul>
Cause		Possible Solution
Deceleration time is too short and regenerative energy is flowing from the motor into the drive.		<ul style="list-style-type: none"> <li>Increase the deceleration time (C1-02, C1-04).</li> <li>Install dynamic braking options.</li> <li>Enable stall prevention during deceleration (L3-04 = 1). Stall Prevention is enabled as the default setting.</li> </ul>
Fast acceleration time causes the motor to overshoot the speed reference.		<ul style="list-style-type: none"> <li>Check if sudden drive acceleration triggers an overvoltage alarm.</li> <li>Increase the acceleration time.</li> <li>Use longer S-curve acceleration and deceleration times.</li> <li>Enable the Overvoltage Suppression function (L3-11 = 1).</li> <li>Lengthen the S-curve at acceleration end.</li> </ul>
Excessive braking load.		The braking torque was too high, causing regenerative energy to charge the DC bus. Reduce the braking torque, use a dynamic braking option, or lengthen decel time.
Surge voltage entering from the drive input power.		Install a DC reactor. <b>Note:</b> Voltage surge can result from a thyristor convertor and phase advancing capacitor using the same input power supply.
Ground fault in the output circuit causing the DC bus capacitor to overcharge.		<ul style="list-style-type: none"> <li>Check the motor wiring for ground faults.</li> <li>Correct grounding shorts and turn the power back on.</li> </ul>
Improper Setting of Speed Search related parameters. (Includes Speed Search after a momentary power loss and after a fault restart.)		<ul style="list-style-type: none"> <li>Check the settings for Speed Search-related parameters.</li> <li>Enable Speed Search restart function (b3-19 greater than or equal to 1 to 10).</li> <li>Adjust the current level during Speed Search and the deceleration time (b3-02 and b3-03 respectively).</li> <li>Perform Stationary Auto-Tuning for line-to-line resistance and then enable Speed Estimation Speed Search (b3-24 = 1).</li> </ul>
Drive input power voltage is too high.		<ul style="list-style-type: none"> <li>Check the voltage.</li> <li>Lower drive input power voltage within the limits listed in the specifications.</li> </ul>
Drive fails to operate properly due to noise interference.		<ul style="list-style-type: none"> <li>Review the list of possible solutions provided for controlling noise.</li> <li>Review the section on handling noise interference and check the control circuit lines, main circuit lines, and ground wiring.</li> </ul>
Load inertia has been set incorrectly.		<ul style="list-style-type: none"> <li>Check the load inertia settings when using KEB, overvoltage suppression, or Stall Prevention during deceleration.</li> <li>Adjust the load inertia ratio in L3-25 to better match the load.</li> </ul>
Motor hunting occurs.		<ul style="list-style-type: none"> <li>Adjust the parameters that control hunting.</li> <li>Set the gain for Hunting Prevention (n1-02).</li> <li>Adjust the speed feedback detection suppression gain for PM motors (n8-45) and the time constant for pull-in current (n8-47).</li> </ul>
Digital Operator Display		Fault Name
PF	PF	Input Phase Loss
		Drive input power has an open phase or has a large imbalance of voltage between phases. Detected when L8-05 = 1 (enabled).
Cause		Possible Solution
There is phase loss in the drive input power.		<ul style="list-style-type: none"> <li>Check for wiring errors in the main circuit drive input power.</li> <li>Correct the wiring.</li> </ul>
There is loose wiring in the drive input power terminals.		<ul style="list-style-type: none"> <li>Ensure the terminals are tightened properly.</li> <li>Apply the tightening torque as specified in this manual. <a href="#">Refer to Wire Gauges and Tightening Torque on page 73</a></li> </ul>
There is excessive fluctuation in the drive input power voltage.		<ul style="list-style-type: none"> <li>Check the voltage from the drive input power.</li> <li>Review the possible solutions for stabilizing the drive input power.</li> </ul>
There is poor balance between voltage phases.		<ul style="list-style-type: none"> <li>Stabilize drive input power or disable phase loss detection.</li> </ul>
The main circuit capacitors are worn.		<ul style="list-style-type: none"> <li>Check the maintenance time for the capacitors (U4-05).</li> <li>Replace the capacitor if U4-05 is greater than 90%. For instructions on replacing the capacitor, contact Yaskawa or your nearest sales representative.</li> </ul> Check for anything problems with the drive input power. If drive input power appears normal but the alarm continues to occur, replace either the control board or the entire drive. For instructions on replacing the control board, contact Yaskawa or your nearest sales representative.



Digital Operator Display		Fault Name
SC <>	SC	IGBT Short Circuit
Cause		Possible Solution
IGBT fault.		<ul style="list-style-type: none"> <li>Check the wiring to the motor.</li> <li>Turn the power supply off and then on again to check operation.</li> </ul> => If the problem continues, contact your Yaskawa representative or nearest Yaskawa sales office.
IGBT short circuit detection circuit fault.		
Digital Operator Display		Fault Name
SEr	SEr	Too Many Speed Search Restarts
Cause		Possible Solution
Speed Search parameters are set to the wrong values.		<ul style="list-style-type: none"> <li>Reduce the detection compensation gain during Speed Search (b3-10).</li> <li>Increase the current level when attempting Speed Search (b3-17).</li> <li>Increase the detection time during Speed Search (b3-18).</li> <li>Repeat Auto-Tuning.</li> </ul>
The motor is coasting in the opposite direction of the Run command.		Enable Bi-Directional Speed Search (b3-14 = 1).
Digital Operator Display		Fault Name
STo	STo	Motor Pull Out or Step Out Detection
Cause		Possible Solution
The wrong motor code is set (Yaskawa motors only).		<ul style="list-style-type: none"> <li>Enter the correct motor code for the PM being used into E5-01.</li> <li>For special-purpose motors, enter the correct data to all E5 parameters according to the test report provided for the motor.</li> </ul>
Load is too heavy.		<ul style="list-style-type: none"> <li>Increase the load inertia for PM motor (n8-55).</li> <li>Increase the pull-in current during accel/decel (n8-51).</li> <li>Reduce the load.</li> <li>Increase the motor or drive capacity.</li> </ul>
Load inertia is too heavy.		Increase the load inertia for PM motor (n8-55).
Acceleration and deceleration times are too short.		<ul style="list-style-type: none"> <li>Increase the acceleration and deceleration times (C1-01 through C1-04).</li> <li>Increase the S-curve acceleration and deceleration times (C2-01).</li> </ul>
Speed response is too slow.		Increase the load inertia for PM motor (n8-55).
Digital Operator Display		Fault Name
THo <>	THo	Thermistor Disconnect
Cause		Possible Solution
The motor thermistor is not connected properly.		Check the wiring for the thermistor.
Digital Operator Display		Fault Name
UL3	UL3	Undertorque Detection 1
Cause		Possible Solution
Parameter settings are not appropriate for the load.		Check the settings of parameters L6-02 and L6-03.
There is a fault on the machine side.		Check the load for any problems.
Digital Operator Display		Fault Name
UL6	UL6	Motor Underload
Cause		Possible Solution
The output current has fallen below the motor underload curve defined in L6-14 for longer than the time set to L6-03.		Adjust the value set to L6-14 so that output current remains above the motor underload curve during normal operation.
Digital Operator Display		Fault Name
UnbC <>	UnbC	Current Unbalance
Cause		Possible Solution
The internal current sensor has detected a current unbalance situation.		<ul style="list-style-type: none"> <li>Check wiring.</li> <li>Check for damaged transistors.</li> <li>Check for short circuits or grounding problems on the connected motor.</li> </ul>
Digital Operator Display		Fault Name
Uv1	Uv1	DC Bus Undervoltage
Cause		Possible Solution
Input power phase loss.		<ul style="list-style-type: none"> <li>The main circuit drive input power is wired incorrectly.</li> <li>Correct the wiring.</li> </ul>
One of the drive input power wiring terminals is loose.		<ul style="list-style-type: none"> <li>Ensure there are no loose terminals.</li> <li>Apply the tightening torque specified in this manual to fasten the terminals. <i>Refer to Wire Gauges and Tightening Torque on page 73</i></li> </ul>
There is a problem with the voltage from the drive input power.		<ul style="list-style-type: none"> <li>Check the voltage.</li> <li>Correct the voltage to be within the range listed in drive input power specifications.</li> <li>If there is no problem with the power supply to the main circuit, check for problems with the main circuit magnetic contactor.</li> </ul>
The power has been interrupted.		Correct the drive input power.

## 6.4 Fault Detection

The main circuit capacitors are worn.		<ul style="list-style-type: none"> <li>Check the maintenance time for the capacitors (U4-05).</li> <li>Replace either the control board or the entire drive if U4-05 exceeds 90%. For instructions on replacing the control board, contact Yaskawa or your nearest sales representative.</li> </ul>
The relay or contactor on the soft-charge bypass circuit is damaged.		<ul style="list-style-type: none"> <li>Cycle power to the drive and see if the fault reoccurs.</li> <li>If the problem continues, replace either the control board or the entire drive. For instructions on replacing the control board, contact Yaskawa or your nearest sales representative.</li> <li>Check monitor U4-06 for the performance life of the soft-charge bypass.</li> <li>Replace either the control board or the entire drive if U4-06 exceeds 90%. For instructions on replacing the control board, contact Yaskawa or your nearest sales representative.</li> </ul>
Digital Operator Display		Fault Name
Uv2	Uv2	Control Power Supply Voltage Fault
Cause		Possible Solution
For models CIMR-E□2A0004 through 2A0056 and CIMR-E□4A0002 through 4A0031: L2-02 was changed from its default value without installing a Momentary Power Loss Ride-Thru unit.		Correct the setting to L2-02 or install an optional Momentary Power Loss Ride-Thru unit.
Control power supply wiring is damaged.		<ul style="list-style-type: none"> <li>Cycle power to the drive. Check if the fault reoccurs.</li> <li>If the problem continues, replace the control board, the entire drive, or the control power supply.</li> </ul>
Internal circuitry is damaged.		<ul style="list-style-type: none"> <li>Cycle power to the drive. Check if the fault reoccurs.</li> <li>If the problem continues, replace either the control board or the entire drive. For instructions on replacing the control board, contact Yaskawa or your nearest sales representative.</li> </ul>
Digital Operator Display		Fault Name
Uv3	Uv3	Undervoltage 3 (Soft-Charge Bypass Circuit Fault)
Cause		Possible Solution
The relay or contactor on the soft-charge bypass circuit is damaged.		<ul style="list-style-type: none"> <li>Cycle power to the drive and see if the fault reoccurs.</li> <li>If the problem continues, replace either the control board or the entire drive. For instructions on replacing the control board, contact Yaskawa or your nearest sales representative.</li> <li>Check monitor U4-06 for the performance life of the soft-charge bypass.</li> <li>Replace either the control board or the entire drive if U4-06 exceeds 90%. For instructions on replacing the control board, contact Yaskawa or your nearest sales representative.</li> </ul>
Digital Operator Display		Fault Name
Uv4 <2>	Uv4	Gate Drive Board Undervoltage
Cause		Possible Solution
Not enough power is being supplied to the gate drive board.		<ul style="list-style-type: none"> <li>Cycle power to the drive and see if the fault reoccurs. <a href="#">Refer to Diagnosing and Resetting Faults on page 287.</a></li> <li>If the problem continues, replace either the gate drive board or the entire drive. For instructions on replacing the gate board, contact Yaskawa or a Yaskawa representative.</li> </ul>
Digital Operator Display		Fault Name
voF	voF	Output Voltage Detection Fault
Cause		Possible Solution
Hardware is damaged.		Replace either the control board or the entire drive. For instructions on replacing the control board, contact Yaskawa or your nearest sales representative.

<1> Displayed as [PF00] or [PF20] when occurring at drive power up. When one of the faults occurs after successfully starting the drive, the display will show [PF01] or [PF21].

<2> Occurs in models CIMR-E□4A0930 and 4A1200.

<3> Valid from the drive software version S8001 and later.

## 6.5 Alarm Detection

### ◆ Alarm Codes, Causes, and Possible Solutions

Alarms are drive protection functions that do not necessarily cause the drive to stop. Once the cause of an alarm is removed, the drive will return to the same status as it was before the alarm occurred.

When an alarm has been triggered, the ALM light on the digital operator display blinks and the alarm code display flashes. If a multi-function output is set for an alarm (H2-□□ = 10), that output terminal will be triggered.

**Note:** If a multi-function output is set to close when an alarm occurs (H2-□□ = 10), it will also close when maintenance periods are reached, triggering alarms LT-1 through LT-4 (triggered only if H2-□□ = 2F).

**Table 6.11 Alarm Codes, Causes, and Possible Solutions**

Digital Operator Display		Minor Fault Name
<i>AEr</i>	AEr	Communication Option Station Number Setting Error (CC-Link, CANopen, MECHATROLINK-II)
Cause		Possible Solutions
Station number is set outside the possible setting range.		<ul style="list-style-type: none"> <li>Set parameter F6-10 to the proper value if a CC-Link option card is used.</li> <li>Set parameter F6-35 to the proper value if a CANopen option card is used.</li> </ul>
Digital Operator Display		Minor Fault Name
<i>bb</i>	bb	Baseblock
Cause		Possible Solutions
External baseblock signal was entered via one of the multi-function input terminals (S1 to S8).		Check external sequence and baseblock signal input timing.
Digital Operator Display		Minor Fault Name
<i>bUS</i>	bUS	Option Communication Error
Cause		Possible Solutions
Connection is broken or master controller stopped communicating.		<ul style="list-style-type: none"> <li>Check for faulty wiring.</li> <li>Correct the wiring.</li> <li>Check for disconnected cables and short circuits. Repair as needed.</li> </ul>
Option card is damaged.		If there are no problems with the wiring and the fault continues to occur, replace the option card.
The option card is not properly connected to the drive.		<ul style="list-style-type: none"> <li>The connector pins on the option card are not properly lined up with the connector pins on the drive.</li> <li>Reinstall the option card.</li> </ul>
A data error occurred due to noise.		<ul style="list-style-type: none"> <li>Check options available to minimize the effects of noise.</li> <li>Take steps to counteract noise in the control circuit wiring, main circuit lines and ground wiring.</li> <li>Try to reduce noise on the controller side.</li> <li>Use surge absorbers on magnetic contactors or other equipment causing the disturbance.</li> <li>Use recommended cables or some other type of shielded line. Ground the shield to the controller side or on the input power side.</li> <li>All wiring for comm. devices should be separated from drive input power lines. Install an EMC noise filter to the drive input power.</li> </ul>
Digital Operator Display		Minor Fault Name
<i>CALL</i>	CALL	Serial Communication Transmission Error
Cause		Possible Solutions
Communications wiring is faulty, there is a short circuit, or something is not connected properly.		<ul style="list-style-type: none"> <li>Check for wiring errors.</li> <li>Correct the wiring.</li> <li>Check for disconnected cables and short circuits. Repair as needed.</li> </ul>
Programming error on the master side.		Check communications at start-up and correct programming errors.
Communications circuitry is damaged.		<ul style="list-style-type: none"> <li>Perform a self-diagnostics check.</li> <li>If the problem continues, replace either the control board or the entire drive. For instructions on replacing the control board, contact Yaskawa or your nearest sales representative.</li> </ul>
Termination resistor setting is incorrect.		A termination resistor must be installed at both ends of a communication line. Slave drives must have the internal termination resistor switch set correctly. Place DIP switch S2 to the ON position.
Digital Operator Display		Minor Fault Name
<i>CE</i>	CE	MEMOBUS/Modbus Communication Error
Cause		Possible Solutions
A data error occurred due to noise.		<ul style="list-style-type: none"> <li>Check options available to minimize the effects of noise.</li> <li>Take steps to counteract noise in the control circuit wiring, main circuit lines, and ground wiring.</li> <li>Reduce noise on the controller side.</li> <li>Use surge absorbers for the magnetic contactors or other components that may be causing the disturbance.</li> <li>Use only recommended shielded line. Ground the shield on the controller side or on the drive input power side.</li> <li>Separate all wiring for comm. devices from drive input power lines. Install an EMC noise filter to the drive input power supply.</li> </ul>
Communication protocol is incompatible.		<ul style="list-style-type: none"> <li>Check the H5 parameter settings as well as the protocol setting in the controller.</li> <li>Ensure settings are compatible.</li> </ul>
The CE detection time (H5-09) is set shorter than the time required for a communication cycle to take place.		<ul style="list-style-type: none"> <li>Check the PLC.</li> <li>Change the software settings in the PLC.</li> <li>Set a longer CE detection time (H5-09).</li> </ul>
Incompatible PLC software settings or there is a hardware problem.		<ul style="list-style-type: none"> <li>Check the PLC.</li> <li>Remove the cause of the error on the controller side.</li> </ul>

## 6.5 Alarm Detection

Communications cable is disconnected or damaged.		<ul style="list-style-type: none"> <li>Check the connector to make sure the cable has a signal.</li> <li>Replace the communications cable.</li> </ul>
Digital Operator Display		Minor Fault Name
$CrST$	CrST	Cannot Reset
Cause		Possible Solutions
A fault reset command was entered while the Run command was still present.		<ul style="list-style-type: none"> <li>Ensure that a Run command cannot be entered from the external terminals or option card during fault reset.</li> <li>Turn off the Run command.</li> </ul>
Digital Operator Display		Minor Fault Name
$dnE$	dnE	Drive Disabled
Cause		Possible Solutions
<p>“Drive Enable” is set to a multi-function contact input (H1-□□ = 6A) and that signal was switched off.</p> <p>An input set for "Bypass/Drive enable 2" (H1-□□ = 70) is open while another input terminal that enables the Run command is closed.</p>		Check the operation sequence.
Digital Operator Display		Minor Fault Name
$EF$	EF	Forward/Reverse Run Command Input Error
		Both forward run and reverse run closed simultaneously for over 0.5 s.
Cause		Possible Solutions
Sequence error		Check the forward and reverse command sequence and correct the problem. <b>Note:</b> When minor fault EF detected, motor ramps to stop.
Digital Operator Display		Minor Fault Name
$EF0$	EF0	Option Card External Fault
		An external fault condition is present.
Cause		Possible Solutions
An external fault was received from the PLC with F6-03 = 3 (causing the drive to continue running when an external fault occurs).		<ul style="list-style-type: none"> <li>Remove the cause of the external fault.</li> <li>Remove the external fault input from the PLC.</li> </ul>
There is a problem with the PLC program.		Check the PLC program and correct problems.
Digital Operator Display		Minor Fault Name
$EF1$	EF1	External fault (input terminal S1)
		External fault at multi-function input terminal S1.
$EF2$	EF2	External fault (input terminal S2)
		External fault at multi-function input terminal S2.
$EF3$	EF3	External fault (input terminal S3)
		External fault at multi-function input terminal S3.
$EF4$	EF4	External fault (input terminal S4)
		External fault at multi-function input terminal S4.
$EF5$	EF5	External fault (input terminal S5)
		External fault at multi-function input terminal S5.
$EF6$	EF6	External fault (input terminal S6)
		External fault at multi-function input terminal S6.
$EF7$	EF7	External fault (input terminal S7)
		External fault at multi-function input terminal S7.
$EF8$	EF8	External fault (input terminal S8)
		External fault at multi-function input terminal S8.
Cause		Possible Solutions
An external device has tripped an alarm function.		Remove the cause of the external fault and reset the multi-function input value.
Wiring is incorrect.		<ul style="list-style-type: none"> <li>Ensure the signal lines have been connected properly to the terminals assigned for external fault detection (H1-□□ = 20 to 2F).</li> <li>Reconnect the signal line.</li> </ul>
Multi-function contact inputs are set incorrectly.		<ul style="list-style-type: none"> <li>Check if the unused terminals have been set for H1-□□ = 20 to 2F (External Fault).</li> <li>Change the terminal settings.</li> </ul>
Digital Operator Display		Minor Fault Name
$FbH$	FbH	Excessive PI Feedback
		The PI feedback input is higher than the level set in b5-36 for longer than the time set in b5-37, and b5-12 is set to 1 or 4.
Cause		Possible Solutions
Parameters settings for b5-36 and b5-37 are incorrect.		Check parameters b5-36 and b5-37.
PI feedback wiring is faulty.		Correct the wiring.
Feedback sensor has malfunctioned.		Check the sensor and replace it if damaged.
Feedback input circuit is damaged.		Replace either the control board or the entire drive. For instructions on replacing the control board, contact Yaskawa or your nearest sales representative.

Digital Operator Display		Minor Fault Name
<i>FbL</i>	FbL	PI Feedback Loss The PI feedback input is lower than the level set in b5-13 for longer than the time set in b5-14, and b5-12 is set to 1 or 4.
<b>Cause</b>		<b>Possible Solutions</b>
Parameters settings for b5-13 and b5-14 are incorrect.		Check parameters b5-13 and b5-14.
PI feedback wiring is faulty.		Correct the wiring.
Feedback sensor has malfunctioned.		Check the sensor and replace it if damaged.
Feedback input circuit is damaged.		Replace either the control board or the entire drive. For instructions on replacing the control board, contact Yaskawa or your nearest sales representative.
Digital Operator Display		Minor Fault Name
<i>Hbb</i>	Hbb	Hardwire Baseblock Signal Input Both Hardwire Baseblock Input channels are open.
<b>Cause</b>		<b>Possible Solutions</b>
Both Hardwire Baseblock Inputs H1 and H2 are open.		<ul style="list-style-type: none"> <li>• Check signal status at the input terminals H1 and H2.</li> <li>• Check the Sink/Source Selection for the digital inputs.</li> <li>• If the Hardwire Baseblock function is not utilized, check if the terminals H1-HC, and H2-HC are linked.</li> </ul>
Internally, both Hardwire Baseblock channels are broken.		Replace either the control board or the entire drive. For instructions on replacing the control board, contact Yaskawa or your nearest sales representative.
Digital Operator Display		Minor Fault Name
<i>HbbF</i>	HbbF	Hardwire Baseblock Signal Input One Hardwire Baseblock channel is open while the other one is closed.
<b>Cause</b>		<b>Possible Solutions</b>
The signals to the Hardwire Baseblock inputs are wrong or the wiring is incorrect.		Check signal status at the input terminals H1 and H2. If the Hardwire Baseblock function is not utilized, the terminals H1-HC, and H2-HC must be linked.
One of the Hardwire Baseblock channels is faulty.		Replace either the control board or the entire drive. For instructions on replacing the control board, contact Yaskawa or your nearest sales representative.
Digital Operator Display		Minor Fault Name
<i>HCA</i>	HCA	Current Alarm Drive current exceeded overcurrent warning level (150% of the rated current).
<b>Cause</b>		<b>Possible Solutions</b>
Load is too heavy.		Either reduce the load for applications with repetitive operation (repetitive stops and starts, etc.), or replace the drive.
Acceleration and deceleration times are too short.		<ul style="list-style-type: none"> <li>• Calculate the torque required during acceleration and for the inertia moment.</li> <li>• If the torque level is not right for the load, take the following steps:</li> <li>• Increase the acceleration and deceleration times (C1-01 through C1-04).</li> <li>• Increase the capacity of the drive.</li> </ul>
A special-purpose motor is being used, or the drive is attempting to run a motor greater than the maximum allowable capacity.		<ul style="list-style-type: none"> <li>• Check the motor capacity.</li> <li>• Use a motor appropriate for the drive. Ensure the motor is within the allowable capacity range.</li> </ul>
The current level increased due to Speed Search after a momentary power loss or while attempting to perform a fault restart.		The alarm will appear only briefly. There is no need to take action to prevent the alarm from occurring in such instances.
Digital Operator Display		Minor Fault Name
<i>LT-1</i>	LT-1	Cooling Fan Maintenance Time The cooling fan has reached its expected maintenance period and may need to be replaced. <b>Note:</b> An alarm output (H2-□□ = 10) will only be triggered if H2-□□ = 2F.
<b>Cause</b>		<b>Possible Solutions</b>
The cooling fan has reached 90% of its expected performance life.		Replace the cooling fan and reset the Maintenance Monitor by setting o4-03 to 0.
Digital Operator Display		Minor Fault Name
<i>LT-2</i>	LT-2	Capacitor Maintenance Time The main circuit and control circuit capacitors are nearing the end of their expected performance life. <b>Note:</b> An alarm output (H2-□□ = 10) will only be triggered if H2-□□ = 2F.
<b>Cause</b>		<b>Possible Solutions</b>
The main circuit and control circuit capacitors have reached 90% of their expected performance life.		Replace either the control board or the entire drive. For instructions on replacing the control board, contact Yaskawa or your nearest sales representative.
Digital Operator Display		Minor Fault Name
<i>LT-3</i>	LT-3	Soft Charge Bypass Relay Maintenance Time The DC bus soft charge relay is nearing the end of its expected performance life. <b>Note:</b> An alarm output (H2-□□ = 10) will only be triggered if H2-□□ = 2F.
<b>Cause</b>		<b>Possible Solutions</b>
The DC bus soft charge relay has reached 90% of their expected performance life.		Replace either the control board or the entire drive. For instructions on replacing the control board, contact Yaskawa or your nearest sales representative.
Digital Operator Display		Minor Fault Name
<i>LT-4</i>	LT-4	IGBT Maintenance Time (50%) IGBTs have reached 50% of their expected performance life. <b>Note:</b> An alarm output (H2-□□ = 10) will only be triggered if H2-□□ = 2F.
<b>Cause</b>		<b>Possible Solutions</b>
IGBTs have reached 50% of their expected performance life.		Check the load, carrier frequency, and output frequency.

## 6.5 Alarm Detection

Digital Operator Display		Minor Fault Name
oH	oH	Heatsink Overheat
		The temperature of the heatsink exceeded the overheat pre-alarm level set to L8-02 (90-100°C). Default value for L8-02 is determined by drive capacity (o2-04).
Cause		Possible Solutions
Surrounding temperature is too high		<ul style="list-style-type: none"> <li>Check the surrounding temperature.</li> <li>Improve the air circulation within the enclosure panel.</li> <li>Install a fan or air conditioner to cool surrounding area.</li> <li>Remove anything near drive that may cause extra heat.</li> </ul>
Internal cooling fan has stopped.		<ul style="list-style-type: none"> <li>Replace the cooling fan. <i>Refer to Cooling Fan Component Names on page 303.</i></li> <li>After replacing the drive, reset the cooling fan maintenance parameter to (o4-03 = "0").</li> </ul>
Airflow around the drive is restricted.		<ul style="list-style-type: none"> <li>Provide proper installation space around the drive as indicated in the manual. <i>Refer to Installation Orientation and Spacing on page 44.</i></li> <li>Allow for the specified space and ensure that there is sufficient circulation around the control panel.</li> <li>Check for dust or foreign materials clogging cooling fan.</li> <li>Clear debris caught in the fan that restricts air circulation.</li> </ul>
Digital Operator Display		Minor Fault Name
oH2	oH2	Drive Overheat Alarm
		"Drive Overheat Alarm" was input to a multi-function input terminal, S1 through S8 (H1-□□ = B)
Cause		Possible Solutions
An external device triggered an overheat Alarm in the drive.		<ul style="list-style-type: none"> <li>Search for the device that tripped the overheat warning.</li> <li>Solving the problem will clear the warning.</li> </ul>
Digital Operator Display		Minor Fault Name
oH3	oH3	Motor Overheat
		The motor overheat signal entered to a multi-function analog input terminal exceeded the alarm level (H3-02, H3-06 or H3-10 = E).
Cause		Possible Solutions
Motor thermostat wiring is fault (PTC input).		Repair the PTC input wiring.
There is a fault on the machine side (e.g., the machine is locked up).		<ul style="list-style-type: none"> <li>Check the status of the machine.</li> <li>Remove the cause of the fault.</li> </ul>
Motor has overheated.		<ul style="list-style-type: none"> <li>Check the load size, accel/decel times, and cycle times.</li> <li>Decrease the load.</li> <li>Increase accel and decel times (C1-01 to C1-04).</li> <li>Adjust the preset V/f pattern (E1-04 through E1-10). This will mainly involve reducing E1-08 and E1-10. <b>Note:</b> Do not lower E1-08 and E1-10 excessively, because this reduces load tolerance at low speeds.</li> <li>Check the motor-rated current.</li> <li>Enter motor-rated current on motor nameplate (E2-01).</li> <li>Ensure the motor cooling system is operating normally.</li> <li>Repair or replace the motor cooling system.</li> </ul>
Digital Operator Display		Minor Fault Name
oH5 <>	oH5	Motor Overheat (NTC Input)
		The motor temperature exceeded the level set in L1-16.
Cause		Possible Solution
Motor has overheated.		<ul style="list-style-type: none"> <li>Reduce the load.</li> <li>Check the ambient temperature.</li> </ul>
Digital Operator Display		Minor Fault Name
oL3	oL3	Overtorque 1
		Drive output current was greater than L6-02 for longer than the time set in L6-03.
Cause		Possible Solutions
Inappropriate parameter settings.		Check parameters L6-02 and L6-03.
There is a fault on the machine side (e.g., the machine is locked up).		<ul style="list-style-type: none"> <li>Check the status of the machine.</li> <li>Remove the cause of the fault.</li> </ul>
Digital Operator Display		Minor Fault Name
ou	ov	DC Bus Overvoltage
		The DC bus voltage exceeded the trip point. For 200 V class: approximately 410 V For 400 V class: approximately 820 V
Cause		Possible Solutions
Surge voltage present in the drive input power.		<ul style="list-style-type: none"> <li>Install a DC reactor or an AC reactor.</li> <li>Voltage surge can result from a thyristor convertor and a phase advancing capacitor operating on the same drive input power system.</li> </ul>
The motor is short-circuited.		<ul style="list-style-type: none"> <li>Check the motor power cable, relay terminals and motor terminal box for short circuits.</li> <li>Correct grounding shorts and turn the power back on.</li> </ul>
Ground current has over-charged the main circuit capacitors via the drive input power.		
Noise interference causes the drive to operate incorrectly.		<ul style="list-style-type: none"> <li>Review possible solutions for handling noise interference.</li> <li>Review section on handling noise interference and check control circuit lines, main circuit lines and ground wiring.</li> <li>If the magnetic contactor is identified as a source of noise, install a surge protector to the MC coil.</li> </ul>
		Set number of fault restarts (L5-01) to a value other than 0.
Digital Operator Display		Minor Fault Name
PASS	PASS	MEMOBUS/Modbus Comm. Test Mode Complete
Cause		Possible Solutions
MEMOBUS/Modbus test has finished normally.		This verifies that the test was successful.

Digital Operator Display		Minor Fault Name
SE	SE	MEMOBUS/Modbus Communication Test Mode Error <b>Note:</b> This alarm will not trigger a multi-function output terminal that is set for alarm output (H2-□□ = 10).
<b>Cause</b>		<b>Possible Solutions</b>
A digital input set to 67H (MEMOBUS/Modbus test) was closed while the drive was running.		Stop the drive and run the test again.
Digital Operator Display		Minor Fault Name
THo <>	THo	Thermistor Disconnect The thermistor that detects motor temperature has become disconnected.
<b>Cause</b>		<b>Possible Solutions</b>
The motor thermistor is not connected properly.		Check the thermistor wiring.
Digital Operator Display		Minor Fault Name
TrPC	TrPC	IGBT Maintenance Time (90%) IGBTs have reached 90% of their expected performance life.
<b>Cause</b>		<b>Possible Solutions</b>
IGBTs have reached 90% of their expected performance life.		Replace the drive.
Digital Operator Display		Minor Fault Name
UL3	UL3	Undertorque Detection 1 Drive output current less than L6-02 for longer than L6-03 time.
<b>Cause</b>		<b>Possible Solutions</b>
Inappropriate parameter settings.		Check parameters L6-02 and L6-03.
Load has dropped or decreased significantly.		Check for broken parts in the transmission system.
Digital Operator Display		Minor Fault Name
UL6	UL6	Underload Detection 6
<b>Cause</b>		<b>Possible Solutions</b>
Load has dropped or decreased under the motor underload curve.		Check parameters L6-13 and L6-14.
Digital Operator Display		Minor Fault Name
Uv	Uv	Undervoltage One of the following conditions was true when the drive was stopped and a Run command was entered: <ul style="list-style-type: none"> <li>DC bus voltage dropped below the level specified in L2-05.</li> <li>Contactor to suppress inrush current in the drive was opened.</li> <li>Low voltage in the control drive input power. This alarm outputs only if L2-01 is not 0 and DC bus voltage is under L2-05.</li> </ul>
<b>Cause</b>		<b>Possible Solutions</b>
Phase loss in the drive input power.		Check for wiring errors in the main circuit drive input power. Correct the wiring.
Loose wiring in the drive input power terminals.		<ul style="list-style-type: none"> <li>Ensure the terminals have been properly tightened.</li> <li>Apply the tightening torque to the terminals as specified. <a href="#">Refer to Wire Gauges and Tightening Torque on page 73</a></li> </ul>
There is a problem with the drive input power voltage.		<ul style="list-style-type: none"> <li>Check the voltage.</li> <li>Lower the voltage of the drive input power so that it is within the limits listed in the specifications.</li> </ul>
Drive internal circuitry is worn.		<ul style="list-style-type: none"> <li>Check the maintenance time for the capacitors (U4-05).</li> <li>Replace either the control board or the entire drive if U4-05 exceeds 90%. For instructions on replacing the control board, contact Yaskawa or your nearest sales representative.</li> </ul>
The drive input power transformer is too small and voltage drops when the power is switched on.		<ul style="list-style-type: none"> <li>Check for an alarm when the magnetic contactor, line breaker, and leakage breaker are closed.</li> <li>Check the capacity of the drive input power transformer.</li> </ul>
Air inside the drive is too hot.		<ul style="list-style-type: none"> <li>Check the temperature inside the drive.</li> </ul>
The CHARGE light is broken or disconnected.		Replace either the control board or the entire drive. For instructions on replacing the control board, contact Yaskawa or your nearest sales representative.
Digital Operator Display		Minor Fault Name
voF	voF	Output Voltage Detection Fault There is a problem with the output voltage.
<b>Cause</b>		<b>Possible Solutions</b>
Hardware is damaged.		Replace either the control board or the entire drive. For instructions on replacing the control board, contact Yaskawa or your nearest sales representative.
Digital Operator Display		Minor Fault Name
WrUn	WrUn	Waiting for Run A Run command has been issued and the drive is waiting to begin running the motor.
<b>Cause</b>		<b>Possible Solutions</b>
Once a Run command has been entered, the drive must wait for the time set in b1-11 to pass before it can begin to operate the motor.		Not an error.

<1> Occurs in models CIMR-E□4A0930 and 4A1200.

## 6.6 Operator Programming Errors

### ◆ oPE Codes, Causes, and Possible Solutions

An Operator Programming Error (oPE) occurs when a contradictory parameter is set or an individual parameter is set to an inappropriate value.

The drive will not operate until the parameter or parameters causing the problem are set correctly. An oPE, however, does not trigger an alarm or fault output. If an oPE occurs, investigate the cause and *Refer to oPE Codes, Causes, and Possible Solutions on page 280* for the appropriate action. When an oPE appears on the operator display, press the ENTER button to view U1-18 and see the parameter that is causing the oPE error (U1-18).

**Table 6.12 oPE Codes, Causes, and Possible Solutions**

Digital Operator Display		Error Name
oPE01	oPE01	Drive Capacity Setting Fault
		Drive capacity and the value set to o2-04 do not match.
Cause		Possible Solutions
The drive model selection (o2-04) and the actual capacity of the drive are not the same.		Correct the value set to o2-04.
Digital Operator Display		Error Name
oPE02	oPE02	Parameter Range Setting Error
		Use U1-18 to find parameters set outside the range.
Cause		Possible Solutions
Parameters were set outside the possible setting range.		Set parameters to the proper values.
<b>Note:</b> When multiple errors occur at the same time, other errors are given precedence over oPE02.		
Digital Operator Display		Error Name
oPE03	oPE03	Multi-Function Input Selection Error
		A contradictory setting is assigned to multi-function contact inputs H1-01 to H1-08.
Cause		Possible Solutions
The same function is assigned to two multi-function inputs. (excludes “Not used” and “External Fault.”)		<ul style="list-style-type: none"> <li>• Ensure all multi-function inputs are assigned to different functions.</li> <li>• Re-enter the multi-function settings to ensure this does not occur.</li> </ul>
The Up command was set but the Down command was not, or vice versa (settings 10 vs. 11).		Correctly set functions that need to be enabled in combination with other functions.
<ul style="list-style-type: none"> <li>• Run/Stop command for a Three-wire sequence was set (H1-□□ = 42), but Forward/Reverse command (H1-□□ = 43) was not.</li> <li>• “Drive Enable” is not selected but H2-□□ is selected during DriveEnable status.</li> <li>• “Drive Enable” is set to multi-function input S1 or S2 (H1-01 = 6A or H1-02 = 6A).</li> <li>• Although the drive has not been set for 3-wire operation, an input terminal is set for Jog 2 (H1-□□ = 69).</li> </ul>		Correctly set functions that need to be enabled in combination with other functions.
Two of the following functions are set at the same time: <ul style="list-style-type: none"> <li>• Up/Down Command (10 vs. 11)</li> <li>• Hold Accel/Decel Stop (A)</li> <li>• Analog Frequency Reference Sample/Hold (1E)</li> <li>• Offset Frequency 1, 2, 3 Calculations (44, 45, 46)</li> <li>• External Reference 1/2 Selection and External Reference 1/2 Selection 2 (2 vs. 36)</li> <li>• Motor pre-heat 2 and Motor pre-heat 1 (50 vs. 60)</li> </ul>		<ul style="list-style-type: none"> <li>• Check if contradictory settings have been assigned to the multi-function input terminals at the same time.</li> <li>• Correct setting errors.</li> </ul>
The Up/Down command (10, 11) is enabled at the same time as PI control (b5-01).		Disable control PI (b5-01 = 0) or disable the Up/Down command.
Settings for N.C. and N.O. input for the following functions were selected at the same time: <ul style="list-style-type: none"> <li>• External Search Command 1 and External Search Command 2 (61 vs. 62)</li> <li>• Fast Stop N.O. and Fast Stop N.C. (15 vs. 17)</li> <li>• KEB for Momentary Power Loss and High Slip Braking (65, 66, 7A, 7B vs. 68)</li> <li>• Motor Switch Command and Accel/Decel Time 2 (16 vs. 1A)</li> <li>• KEB Command 1 and KEB Command 2 (65, 66 vs. 7A, 7B)</li> <li>• FWD Run Command (or REV) and FWD/REV Run Command (2-wire) (40, 41 vs. 42, 43)</li> <li>• External DB Command and Drive Enable (60 vs. 6A)</li> </ul>		Check for contradictory settings assigned to the multi-function input terminals at the same time. Correct setting errors.
One of the following settings was entered while H1-□□ = 2 (External Reference 1/2): <ul style="list-style-type: none"> <li>• b1-15 = 4 (Pulse Train Input) but the pulse train input selection is not set for the frequency reference (H6-01 &gt; 0)</li> <li>• b1-15 or b1-16 set to 3 but no option card is connected</li> <li>• Although b1-15 = 1 (Analog Input) and H3-02 or H3-10 are set to 0 (Frequency Bias)</li> </ul>		Correct the settings for the multi-function input terminal parameters.
H2-□□ = 38 (Drive Enabled) but H1-□□ is not set to 6A (Drive Enable).		
Digital Operator Display		Error Name
oPE04	oPE04	Initialization required.
Cause		Possible Solutions
The drive, control board, or terminal board has been replaced and the parameter settings between the control board and the terminal board no longer match.		To load the parameter settings to the drive that are stored in the terminal board, set A1-03 to 5550. Initialize parameters after drive replacement by setting A1-03 to 1110 or 2220.



Digital Operator Display		Error Name
	oPE05	Run Command/Frequency Reference Source Selection Error
<b>Cause</b>		<b>Possible Solutions</b>
Frequency reference is assigned to an option card (b1-01 = 3) but an input option card is not connected to the drive.		Reconnect the input option card to the drive.
The Run command is assigned to an option card (b1-02 = 3) but an input option card is not connected to the drive.		
Frequency reference is assigned to the pulse train input (b1-01 = 4), but terminal RP is not set for frequency reference input (H6-01 > 0)		Set H6-01 to "0".
Although a communication option card is not connected to the drive, b1-16 is set to 3 while H1-□□ is set to 4 or 36.		
Digital Operator Display		Error Name
	oPE07	Multi-Function Analog Input Selection Error
<b>Cause</b>		<b>Possible Solutions</b>
A contradictory setting is assigned to multi-function analog inputs H3-02, H3-06, or H3-10 and PI functions conflict.		Change the settings to H3-02, H3-06, and H3-10 so that functions no longer conflict. <b>Note:</b> Both 0 (frequency reference bias) and F (not used) can be set to H3-02, H3-06, and H3-10 at the same time.
At least two analog input terminals are set to the same function (i.e., at least two of these parameters has the same setting: H3-02, H3-06, or H3-10).		
The following simultaneous contradictory settings:		Disable one of the PI selections.
• H3-02, H3-06, or H3-10 = B (PI Feedback) while H6-01 (Pulse Train Input) = 1 (PI Feedback)		
• H3-02, H3-06, or H3-10 = C (PI Target Value) while H6-01 = 2 (pulse train input sets the PI target value)		
• H3-02, H3-06, or H3-10 = C (PI Target Value) while b5-18 = 1 (enables b5-19 as the target PI value)		
• H6-01 = 2 (PI target) while b5-18 = 1 (enables b5-19 as the target PI value)		
Digital Operator Display		Error Name
	oPE08	Parameter Selection Error
<b>Cause</b>		<b>Possible Solutions</b>
A function has been set that cannot be used in the motor control method selected.		Check the motor control method and the functions available.
Attempted to use a function that is not valid for the selected control mode.		
In OLV/PM, parameters E5-02 to E5-07 are set to 0.		<ul style="list-style-type: none"> <li>Set the correct motor code in accordance with the motor being used (E5-01).</li> <li>When using a special-purpose motor, set E5-□□ in accordance with the test report provided.</li> </ul>
The following settings have occurred in OLV/PM:		<ul style="list-style-type: none"> <li>Set E5-09 or E5-24 to the correct value, and set the other to "0".</li> <li>Set the motor rated current for PM to "0" (E5-03).</li> </ul>
<ul style="list-style-type: none"> <li>E5-03 does not equal 0</li> <li>E5-09 and E5-24 are both equal to 0, or neither equals 0</li> </ul>		
<b>Note:</b> Use U1-18 to find which parameters are set outside the specified setting range. Other errors are given precedence over oPE08 when multiple errors occur at the same time.		
Digital Operator Display		Error Name
	oPE09	PI Control Selection Fault
<b>Cause</b>		<b>Possible Solutions</b>
PI control function selection is incorrect. Requires that PI control is enabled (b5-01 = 1 or 3).		<ul style="list-style-type: none"> <li>Set b5-15 to another value besides 0.</li> <li>Set the stopping method to coast to stop or ramp to stop (b1-03 = 0 or 1).</li> </ul>
The following simultaneous contradictory settings have occurred:		
<ul style="list-style-type: none"> <li>b5-15 is not set to 0.0 (PI Sleep Function Operation Level)</li> <li>The stopping method is set to either DC Injection Braking or coast to stop with a timer (b1-03 = 2 or 3).</li> </ul>		
PI control is set to b5-01 = 1, but the lower limit for the frequency reference (d2-02) is not set to 0 while reverse output is enabled (b5-11 = 1).		Correct the parameter settings.
PI control is set to b5-01 = 3, but the lower limit for the frequency reference (d2-01) is not 0.		Correct the parameter settings.
Digital Operator Display		Error Name
	oPE10	V/f Data Setting Error
<b>Cause</b>		<b>Possible Solutions</b>
The following setting errors have occurred where:		Correct the settings for E1-04, E1-06, E1-07, E1-09, and E1-11.
<ul style="list-style-type: none"> <li>E1-04 is greater than or equal to E1-06, E1-06 is greater than or equal to E1-07, E1-07 is greater than or equal to E1-09, or E1-09 is greater than or equal to E1-11.</li> </ul>		
V/f Pattern Setting Error		
Digital Operator Display		Error Name
	oPE11	Carrier Frequency Setting Error
<b>Cause</b>		<b>Possible Solutions</b>
Correct the setting for the carrier frequency.		Correct the parameter settings.
The following simultaneous contradictory settings: C6-05 is greater than 6 and C6-04 is greater than C6-03 (carrier frequency lower limit is greater than the upper limit). If C6-05 is less than or equal to 6, the drive operates at C6-03.		
Upper and lower limits between C6-02 and C6-05 contradict each other.		
Digital Operator Display		Error Name
	oPE13	Pulse Monitor Selection Error
<b>Cause</b>		<b>Possible Solutions</b>
Incorrect setting of monitor selection for pulse train (H6-06).		Change scaling for the pulse train monitor or set H6-06 to 101, 102, 105, or 116.
Scaling for the pulse train monitor is set to 0 (H6-07 = 0) while H6-06 is not set to 101, 102, 105, or 116.		

## 6.6 Operator Programming Errors

---

Digital Operator Display		Error Name
<i>oPE 16</i>	oPE16	Energy Savings Constants Error
<b>Cause</b>		<b>Possible Solutions</b>
In AOLV/PM the automatically calculated energy saving coefficients are out of the allowable range.		Check and correct the motor data in E5 parameters.

## 6.7 Auto-Tuning Fault Detection

Auto-Tuning faults are shown below. When the following faults are detected, the fault is displayed on the digital operator and the motor coasts to a stop. Auto-Tuning faults do not trigger an multi-function terminal set for fault or alarm output.

An End□ error indicates that although Auto-Tuning has completely successful, there is some discrepancy in the calculations the drive made. If an End□ error occurs, check for what might be causing the error using the table below, and perform Auto-Tuning again once the problem has been taken care of. If there appears to be no problem despite the End□ error being displayed, go ahead and start the application.

### ◆ Auto-Tuning Codes, Causes, and Possible Solutions

Table 6.13 Auto-Tuning Codes, Causes, and Possible Solutions

Digital Operator Display		Error Name
End1	End1	Excessive V/f Setting (detected only during Rotational Auto-Tuning for V/f control (T1-01 = 3), and displayed after Auto-Tuning is complete)
Cause		Possible Solutions
The torque reference exceeded 20% during Auto-Tuning.		<ul style="list-style-type: none"> <li>• Before Auto-Tuning the drive, verify the information written on the motor nameplate and enter that data to T1-03 through T1-05.</li> <li>• Enter proper information to parameters T1-03 to T1-05 and repeat Auto-Tuning.</li> <li>• If possible, disconnect the motor from the load and perform Auto-Tuning. If the load cannot be uncoupled, simply use the Auto-Tuning results as they are.</li> </ul>
The results from Auto-Tuning the no-load current exceeded 80%.		
Digital Operator Display		Error Name
End3	End3	Rated Current Setting Alarm (displayed after Auto-Tuning is complete)
Cause		Possible Solutions
The correct current rating printed on the nameplate was not entered into T1-04.		<ul style="list-style-type: none"> <li>• Check the setting of parameter T1-04.</li> <li>• Check the motor data and repeat Auto-Tuning.</li> </ul>
Digital Operator Display		Error Name
End4	End4	Adjusted Slip Calculation Error
Cause		Possible Solutions
The slip that was calculated is outside the allowable range.		<ul style="list-style-type: none"> <li>• Make sure the data entered for Auto-Tuning is correct.</li> </ul>
Digital Operator Display		Error Name
End5	End5	Resistance Tuning Error
Cause		Possible Solutions
The resistance value that was calculated is outside the allowable range.		<ul style="list-style-type: none"> <li>• Double check the data that was entered for the Auto-Tuning process.</li> <li>• Check the motor and motor cable connection for faults.</li> </ul>
Digital Operator Display		Error Name
End7	End7	No-Load Current Alarm
Cause		Possible Solutions
The entered no-load current value was outside the allowable range.		Check and correct faulty motor wiring.
Auto-Tuning results were less than 5% of the motor rated current.		Double check the data that was entered for the Auto-Tuning process.
Digital Operator Display		Error Name
Er-01	Er-01	Motor Data Error
Cause		Possible Solutions
Motor data or data entered during Auto-Tuning was incorrect.		<ul style="list-style-type: none"> <li>• Check that the motor data entered to T1 parameters matches motor nameplate input before Auto-Tuning.</li> <li>• Start Auto-Tuning over again and enter the correct information.</li> </ul>
Motor output power and motor-rated current settings (T1-02 and T1-04) do not match.		<ul style="list-style-type: none"> <li>• Check the drive and motor capacities.</li> <li>• Correct the settings of parameters T1-02 and T1-04.</li> </ul>
Base frequency and motor rated speed (T1-05 and T1-07) do not match.		<ul style="list-style-type: none"> <li>• Set T1-05 and T1-07 to the correct value.</li> <li>• Check if the correct pole number was entered to T1-06.</li> </ul>
Digital Operator Display		Error Name
Er-02	Er-02	Minor Fault
Cause		Possible Solutions
An alarm was triggered during Auto-Tuning.		Exit the Auto-Tuning menu, check the alarm code, remove the alarm cause, and repeat Auto-Tuning.
Digital Operator Display		Error Name
Er-03	Er-03	STOP Button Input
Cause		Possible Solutions
Auto-Tuning canceled by pressing STOP button.		Auto-Tuning did not complete properly and will have to be performed again.

## 6.7 Auto-Tuning Fault Detection

Digital Operator Display		Error Name
$E_r - 04$	Er-04	Line-to-Line Resistance Error
<b>Cause</b>		<b>Possible Solutions</b>
Motor data entered during Auto-Tuning was incorrect.		<ul style="list-style-type: none"> <li>Make sure the data entered to the T1 parameters match the information written on the motor nameplate.</li> <li>Restart Auto-Tuning and enter the correct information.</li> </ul>
Results from Auto-Tuning are outside the parameter setting range or the tuning process took too long.		Check and correct faulty motor wiring.
Motor cable or cable connection faulty.		
Digital Operator Display		Error Name
$E_r - 05$	Er-05	No-Load Current Error
<b>Cause</b>		<b>Possible Solutions</b>
Motor data entered during Auto-Tuning was incorrect.		<ul style="list-style-type: none"> <li>Make sure the data entered to the T1 parameters match the information written on the motor nameplate.</li> <li>Restart Auto-Tuning and enter the correct information.</li> </ul>
Results from Auto-Tuning are outside the parameter setting range or the tuning process took too long.		<ul style="list-style-type: none"> <li>Check and correct faulty motor wiring.</li> <li>Perform Rotational Auto-Tuning.</li> </ul>
The load during Rotational Auto-tuning was too high.		<ul style="list-style-type: none"> <li>Disconnect the motor from machine and restart Auto-Tuning. If motor and load cannot be uncoupled make sure the load is lower than 30%.</li> <li>If a mechanical brake is installed, make sure it is fully lifted during tuning.</li> </ul>
Digital Operator Display		Error Name
$E_r - 08$	Er-08	Rated Slip Error
<b>Cause</b>		<b>Possible Solutions</b>
Motor data entered during Auto-Tuning was incorrect.		<ul style="list-style-type: none"> <li>Make sure the data entered to the T1 parameters match the information written on the motor nameplate.</li> <li>Restart Auto-Tuning and enter the correct information.</li> </ul>
Drive-calculated values outside parameter setting range or the tuning process took too long.		<ul style="list-style-type: none"> <li>Check and correct faulty motor wiring.</li> <li>Perform Rotational Auto-Tuning for V/f control (T1-01 = 3).</li> </ul>
The load during rotational Auto-tuning was too high.		<ul style="list-style-type: none"> <li>Disconnect the motor from machine and restart Auto-Tuning. If motor and load cannot be uncoupled make sure the load is lower than 30%.</li> <li>If a mechanical brake is installed, make sure it is fully lifted during tuning.</li> </ul>
Digital Operator Display		Error Name
$E_r - 09$	Er-09	Acceleration Error
<b>Cause</b>		<b>Possible Solutions</b>
The motor did not accelerate for the specified acceleration time.		<ul style="list-style-type: none"> <li>Increase the acceleration time (C1-01).</li> <li>Check if it is possible to disconnect the machine from the motor.</li> </ul>
The load during Rotational Auto-Tuning for V/f control (T1-01 = 3) was too high.		<ul style="list-style-type: none"> <li>Disconnect the motor from machine and restart Auto-Tuning. If motor and load cannot be uncoupled make sure the load is lower than 30%.</li> <li>If a mechanical brake is installed, make sure it is fully lifted during tuning.</li> </ul>
Digital Operator Display		Error Name
$E_r - 11$	Er-11	Motor Speed Fault
<b>Cause</b>		<b>Possible Solutions</b>
Torque reference is too high.		<ul style="list-style-type: none"> <li>Increase the acceleration time (C1-01).</li> <li>Disconnect the machine from the motor, if possible.</li> </ul>
Digital Operator Display		Error Name
$E_r - 12$	Er-12	Current Detection Error
<b>Cause</b>		<b>Possible Solutions</b>
One of the motor phases is missing: (U/T1, V/T2, W/T3).		Check motor wiring and correct any problems.
Current exceeded the current rating of the drive.		<ul style="list-style-type: none"> <li>Check the motor wiring for a short between motor lines.</li> <li>If a magnetic contactor is used between motors, make sure it is closed.</li> </ul>
The current is too low.		<ul style="list-style-type: none"> <li>Replace either the control board or the entire drive. For instructions on replacing the control board, contact Yaskawa or your nearest sales representative.</li> </ul>
Attempted Auto-Tuning without motor connected to the drive.		Connect the motor and perform Auto-Tuning.
Current detection signal error.		Replace either the control board or the entire drive. For instructions on replacing the control board, contact Yaskawa or your nearest sales representative.

## 6.8 Copy Function Related Displays

### ◆ Tasks, Errors, and Troubleshooting

The table below lists the messages and errors that may appear when using the Copy function.

When executing the tasks offered by the Copy function, the operator will indicate the task being performed. When an error occurs, a code appears on the operator to indicate the error. Note that errors related to the Copy function do not trigger a multi-function output terminal that has been set up to close when a fault or alarm occurs. To clear an error, simply press any key on the operator and the error display will disappear.

**Table 6.14** lists the corrective action that can be taken when an error occurs.

- Note:**
1. Whenever using the copy function, the drive should be fully stopped.
  2. The drive will not accept a Run command while the Copy function is being executed.
  3. Parameters can only be saved to a drive when the voltage class, capacity, control mode, and software version match.

**Table 6.14 Copy Function Task and Error Displays**

Digital Operator Display		Task
<code>CoPy</code>	CoPy	Writing Parameter Settings (flashing)
<b>Cause</b>		<b>Possible Solutions</b>
Parameters are being written to the drive.		Not an error.
<b>Digital Operator Display</b>		<b>Task</b>
<code>CPEr</code>	CPEr	Control Mode Mismatch
<b>Cause</b>		<b>Possible Solutions</b>
Control mode of the parameters to be loaded onto the drive and the control mode already set to the drive don't match.		Check the control mode for the parameters that are to be loaded onto the drive and the control mode set to the drive those parameters will be written to. Set the same control mode using parameter A1-02 and try again.
<b>Digital Operator Display</b>		<b>Task</b>
<code>CPyE</code>	CPyE	Error Writing Data
<b>Cause</b>		<b>Possible Solutions</b>
Failed writing parameters.		Try writing parameters again.
<b>Digital Operator Display</b>		<b>Task</b>
<code>CSEr</code>	CSEr	Copy Unit Error
<b>Cause</b>		<b>Possible Solutions</b>
Hardware fault		Replace the operator or the USB Copy Unit.
<b>Digital Operator Display</b>		<b>Task</b>
<code>dFpS</code>	dFPS	Drive Model Mismatch
<b>Cause</b>		<b>Possible Solutions</b>
The drive from which the parameter were copied and the drive you are attempting to write to are not the same model. <ul style="list-style-type: none"> <li>• The drive the parameters were copied from is a different model drive.</li> <li>• The drive you attempting to write to is a different model.</li> </ul>		Check the model number of the drive that the parameters were copied from and the model of the drive you are attempting to write those parameters to. Make sure the drive from which the parameter are copied and the drive to be written to have the same model numbers and software versions.
<b>Digital Operator Display</b>		<b>Task</b>
<code>End</code>	End	Task Complete
<b>Cause</b>		<b>Possible Solutions</b>
Finished reading, writing, or verifying parameters.		Not an error.
<b>Digital Operator Display</b>		<b>Task</b>
<code>iFEr</code>	iFEr	Communication Error
<b>Cause</b>		<b>Possible Solutions</b>
A communication error occurred between the drive and the operator or the USB copy unit.		Check the cable connection.
A non-compatible cable is being used to connect the USB Copy Unit and the drive.		Use the cable originally packaged with the USB Copy Unit.
<b>Digital Operator Display</b>		<b>Task</b>
<code>ndAT</code>	ndAT	Model, Voltage Class, Capacity Mismatch
<b>Cause</b>		<b>Possible Solutions</b>
The drive the parameters were copied from and the drive you are attempting to write to have different electrical specifications, a different capacity, is set to a different control mode, or is a different model number.		Make sure model numbers and specifications are the same for both drives.
The device being used to write the parameters is blank and does not have any parameters saved on it.		Making sure all connections are correct, and copy the parameter settings onto the USB Copy Unit or the operator.

## 6.8 Copy Function Related Displays

Digital Operator Display		Task
<i>rdEr</i>	rdEr	Error Reading Data
<b>Cause</b>		<b>Possible Solutions</b>
Failed while attempting to read parameter settings from the drive.		Press and hold the READ key on the USB Copy Unit for at least one second to have the unit read parameters from the drive.
Digital Operator Display		Task
<i>rEAd</i>	rEAd	Reading Parameter Settings (flashing)
<b>Cause</b>		<b>Possible Solutions</b>
Displayed while the parameter settings are being read onto the USB Copy Unit.		Not an error.
Digital Operator Display		Task
<i>vAEr</i>	vAEr	Voltage Class, Capacity Mismatch
<b>Cause</b>		<b>Possible Solutions</b>
The drive the parameters were copied from and the drive you performing the Verify mode on have different electrical specifications or are a different capacity.		Make sure electrical specifications and capacities are the same for both drives.
Digital Operator Display		Task
<i>vFyE</i>	vFyE	Parameter settings in the drive and those saved to the copy function are not the same
<b>Cause</b>		<b>Possible Solutions</b>
Indicates that parameter settings that have been Read and loaded onto the Copy Unit or Digital Operator are different.		To have parameters be the same, either write the parameters save on the USB Copy Unit or LCD digital operator onto the drive, or Read the parameter settings on the drive onto the USB Copy Unit.
Digital Operator Display		Task
<i>vrFy</i>	vrFy	Comparing Parameter Settings (flashing)
<b>Cause</b>		<b>Possible Solutions</b>
The Verify mode has confirmed that parameters settings on the drive and parameters read to the copy device are identical.		Not an error.

## 6.9 Diagnosing and Resetting Faults

When a fault occurs and the drive stops, follow the instructions below to remove whatever conditions triggered the fault, then restart the drive.

### ◆ Fault Occurs Simultaneously with Power Loss

**WARNING!** *Electrical Shock Hazard. Ensure there are no short circuits between the main circuit terminals (R/L1, S/L2, and T/L3) or between the ground and main circuit terminals before restarting the drive. Failure to comply may result in serious injury or death and will cause damage to equipment.*

1. Turn on the drive input power.
2. Use monitor parameters U2-□□ to display data on the operating status of the drive just before the fault occurred.
3. Remove the cause of the fault and reset.

- Note:**
1. To find out what faults were triggered, check the fault history in U2-02. Information on drive status when the fault occurred such as the frequency, current, and voltage can be found in U2-03 through U2-20. [Refer to Viewing Fault Trace Data After Fault on page 287](#) for information on how to view fault data.
  2. When the fault continues to be displayed after cycling power, remove the cause of the fault and reset.

### ◆ If the Drive Still has Power After a Fault Occurs

1. Look at the digital operator for information on the fault that occurred.
2. [Refer to Fault Displays, Causes, and Possible Solutions on page 265](#)
3. Reset the fault. [Refer to Fault Reset Methods on page 288](#).



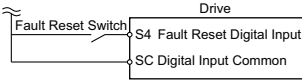
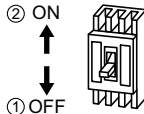
### ◆ Viewing Fault Trace Data After Fault

	Step		Display/Result
1.	Turn on the drive input power. The first screen displays.	→	
2.	Press  until the monitor screen is displayed.	→	
3.	Press  to display the parameter setting screen.	→	
4.	Press  and  until U2-02 (Fault History) is displayed.	→	
5.	Press  to view the most recent fault (oC in this example).	→	
6.	Press  to go back to the U2-02 display.	→	
7.	Press  to view drive status information when fault occurred. Parameters U2-03 through U2-20 help determine the cause of a fault. Parameters to be monitored differ depending on the control mode.	→	

## 6.9 Diagnosing and Resetting Faults

### ◆ Fault Reset Methods

When a fault occurs, the cause of the fault must be removed and the drive must be restarted. The table below lists the different ways to restart the drive.

After the Fault Occurs	Procedure	
Fix the cause of the fault, restart the drive, and reset the fault	Press  on the digital operator.	
Resetting via Fault Reset Digital Input S4	Close then open the fault signal digital input via terminal S4. S4 is set for "Fault Reset" as default (H1-04 = 14).	
If the above methods do not reset the fault, turn off the drive main power supply. Reapply power after the digital operator display is out.		

**Note:** If the Run command is present, the drive will disregard any attempts to reset the fault. The Run command must first be removed before a fault situation can be cleared.



## 6.10 Troubleshooting without Fault Display

This section describes troubleshooting problems that do not trip an alarm or fault.



The following symptoms indicate that the drive is not set correctly for proper performance with the motor. Refer to [Motor Performance Fine-Tuning on page 258](#) for guidance on troubleshooting.

- Motor hunting and oscillation
- Poor motor torque
- Poor speed precision
- Poor motor torque and speed response
- Motor noise

### ◆ Common Problems






Common Problems		Page
Cannot Change Parameter Settings		289
Motor Does Not Rotate Properly after Pressing RUN Button or after Entering External Run Command	Motor Does Not Rotate	290
	Motor Rotates in the Opposite Direction from the Run Command	290
	Motor Rotates in One Direction Only	291
Motor is Too Hot		291
Drive Does Not Allow Selection the Desired Auto-Tuning Mode		291
oPE02 Error Occurs When Lowering the Motor Rated Current Setting		291
Motor Stalls During Acceleration or With Large Loads		291
Drive Frequency Reference Differs from the Controller Frequency Reference Command		292
Excessive Motor Oscillation and Erratic Rotation		292
Deceleration Takes Longer Than Expected with Dynamic Braking Enabled		292
Noise From Drive or Motor cables When the Drive is Powered On		292
Earth Leakage Circuit Breaker (ELCB) Trips During Run		292
Connected Machinery Vibrates When Motor Rotates	Unexpected Noise from Connected Machinery	293
	Oscillation or Hunting	293
PI Output Fault		293
Motor Rotates After the Drive Output is Shut Off (Motor Rotates During DC Injection Braking)		293
Output Frequency is not as High as Frequency Reference		293
Buzzing Sound from Motor at 2 kHz		293
Unstable Motor Speed when Using PM or IPM		294
Motor Does Not Restart after Power Loss		294

### ◆ Cannot Change Parameter Settings

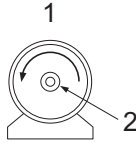
Cause	Possible Solutions
The drive is running the motor (i.e., the Run command is present).	<ul style="list-style-type: none"> <li>• Stop the drive and switch over to the Programming Mode.</li> <li>• Most parameters cannot be edited during run.</li> </ul>
The Access Level is set to restrict access to parameter settings.	<ul style="list-style-type: none"> <li>• Set the Access Level to allow parameters to be edited (A1-01 = 2).</li> </ul>
The operator is not in the Parameter Setup Mode (the screen will display "PAr").	<ul style="list-style-type: none"> <li>• See what mode the operator is currently set for.</li> <li>• Parameters cannot be edited when in the Setup Mode ("STUP"). Switch modes so that "PAr" appears on the screen. Refer to <a href="#">The Drive and Programming Modes on page 101</a>.</li> </ul>
A multi-function contact input terminal is set to allow or restrict parameter editing (H1-01 through H1-08 = 1B).	<ul style="list-style-type: none"> <li>• When the terminal is open, parameters cannot be edited.</li> <li>• Turn on the multi-function contact input set to 1B.</li> </ul>
The wrong password was entered.	<ul style="list-style-type: none"> <li>• If the password entered to A1-04 does not match the password saved to A1-05, then drive settings cannot be changed.</li> <li>• Reset the password.</li> </ul> <p>If you cannot remember the password:</p> <ul style="list-style-type: none"> <li>• Scroll to A1-04. Press the  button and press  at the same time. Parameter A1-05 will appear.</li> <li>• Set a new password to parameter A1-05.</li> </ul>
Undervoltage was detected.	<ul style="list-style-type: none"> <li>• Check the drive input power voltage by looking at the DC bus voltage (U1-07).</li> <li>• Check all main circuit wiring.</li> </ul>

### ◆ Motor Does Not Rotate Properly after Pressing RUN Button or after Entering External Run Command

#### ■ Motor Does Not Rotate

Cause	Possible Solutions
The drive is not in the Drive Mode.	<ul style="list-style-type: none"> <li>Check if the DRV light on the digital operator is lit.</li> <li>Enter the Drive Mode to begin operating the motor. <a href="#">Refer to The Drive and Programming Modes on page 101.</a></li> </ul>
The  button was pushed.	<p>Stop the drive and check if the correct frequency reference source is selected. If the operator keypad shall be the source, the LO/RE button LED must be on. If the source is REMOTE, it must be off. Take the following steps to solve the problem:</p> <ul style="list-style-type: none"> <li>Push the  button.</li> <li>If o2-01 is set to 0, then the LO/RE button will be disabled.</li> </ul>
Auto-Tuning has just completed.	<ul style="list-style-type: none"> <li>When Auto-Tuning completes, the drive is switched back to the Programming Mode. The Run command will not be accepted unless the drive is in the Drive Mode.</li> <li>Use the digital operator to enter the Drive Mode. <a href="#">Refer to The Drive and Programming Modes on page 101.</a></li> </ul>
A Fast Stop was executed and has not yet been reset.	Reset the Fast Stop command.
Settings are incorrect for the source that provides the Run command.	<p>Check parameter b1-02 (Run Command Selection). Set b1-02 so that it corresponds with the correct Run command source.</p> <p>0: Digital operator 1: Control circuit terminal (default setting) 2: MEMOBUS/Modbus communications 3: Option card</p>
There is faulty wiring in the control circuit terminals.	<ul style="list-style-type: none"> <li>Check the wiring for the control terminal.</li> <li>Correct wiring mistakes.</li> <li>Check the input terminal status monitor (U1-10).</li> </ul>
The drive has been set to accept the frequency reference from the incorrect source.	<p>Check parameter b1-01 (Frequency Reference Selection 1). Set b1-01 to the correct source of the frequency reference.</p> <p>0: Digital operator 1: Control circuit terminal (default setting) 2: MEMOBUS/Modbus communications 3: Option card 4: Pulse train input (RP)</p>
The terminal set to accept the main speed reference is set to the incorrect voltage and/or current.	If the frequency reference is set at terminal A1, check parameter H3-01 for the correct signal level selection. If terminal A2 is used, check DIP switch S1 parameter H3-08. If terminal A3 is used, check parameter H3-08. <a href="#">Refer to Terminal A2 Input Signal Selection on page 88.</a>
Selection for the sink/source mode and the internal/external power supply is incorrect.	Check jumper S3. <a href="#">Refer to Sinking/Sourcing Mode Selection for Hardwire Baseblock Inputs on page 85.</a>
Frequency reference is too low.	<ul style="list-style-type: none"> <li>Check the frequency reference monitor (U1-01).</li> <li>Increase the frequency by changing the maximum output frequency (E1-09).</li> </ul>
Multi-function analog input is set up to accept gain for the frequency reference, but no voltage (current) has been provided.	<ul style="list-style-type: none"> <li>Check the multi-function analog input settings.</li> <li>Check if analog input A1, A2, or A3 is set for frequency reference gain (H3-02, H3-10, H3-06 = 1). If so, check if the correct signal is applied to the terminal. The gain and the frequency reference will be 0 if no signal is applied to the gain input.</li> <li>Check if H3-02, H3-10, and H3-06 have been set to the proper values.</li> <li>Check if the analog input value has been set properly. (U1-13 to U1-15)</li> </ul>
The  button was pressed when the drive was started from a REMOTE source.	<ul style="list-style-type: none"> <li>When the  button is pressed, the drive will decelerate to stop.</li> <li>Switch off the Run command and then re-enter a new Run command.</li> <li>The  button can be disabled when o2-02 is set to 0.</li> </ul>
Motor starting torque is too low.	<a href="#">Refer to Motor Performance Fine-Tuning on page 258</a>
Frequency reference value is too low or the drive does not accept the value entered.	Enter a value that is above the minimum output frequency determined by E1-09.
The sequence Start/Stop sequence is set up incorrectly.	<ul style="list-style-type: none"> <li>If the drive is supposed to be set up for a 2-wire sequence, then ensure parameters H1-03 through H1-08 are not set to 0.</li> <li>If the drive is supposed to be set up for a 3-wire sequence, then one of the parameters H1-03 through H1-08 must be set to 0. Terminal S1 will become the Start, terminal S2 will become the Stop input.</li> </ul>

#### ■ Motor Rotates in the Opposite Direction from the Run Command

Cause	Possible Solutions
Phase wiring between the drive and motor is incorrect.	<ul style="list-style-type: none"> <li>Check the motor wiring.</li> <li>Switch two motor cables (U, V, and W) to reverse motor direction.</li> <li>Connect drive output terminals U/T1, V/T2, and W/T3 in the right order to match motor terminals U, V, and W.</li> <li>Change the setting of parameter b1-14.</li> </ul>
The forward direction for the motor is setup incorrectly.	<p>Typically, forward is designated as being counterclockwise when looking from the motor shaft (see figure below).</p>  <ol style="list-style-type: none"> <li>Forward Rotating Motor (looking down the motor shaft)</li> <li>Motor Shaft</li> </ol>

Cause	Possible Solutions
The motor is running at almost 0 Hz and the Speed Search estimated the speed to be in the opposite direction.	<ul style="list-style-type: none"> <li>• Disable bi-directional search (b3-14 = "0") so that Speed Search is performed only in the specified direction.</li> </ul>

**Note:** Check the motor specifications for the forward and reverse directions. The motor specifications will vary depending on the manufacturer of the motor.

### ■ Motor Rotates in One Direction Only

Cause	Possible Solutions
The drive prohibits reverse rotation.	<ul style="list-style-type: none"> <li>• Check parameter b1-04.</li> <li>• Set the drive to allow the motor to rotate in reverse (b1-04 = 0).</li> </ul>
A Reverse run signal has not been entered, although 3-wire sequence is selected.	<ul style="list-style-type: none"> <li>• Make sure that one of the input terminals S3 to S8 used for the 3-wire sequence has been set for reverse.</li> </ul>

### ◆ Motor is Too Hot

Cause	Possible Solutions
The load is too heavy.	<p>If the load is too heavy for the motor, the motor will overheat as it exceeds its rated torque value for an extended period of time. Keep in mind that the motor also has a short-term overload rating in addition to the possible solutions provided below:</p> <ul style="list-style-type: none"> <li>• Reduce the load.</li> <li>• Increase the acceleration and deceleration times.</li> <li>• Check the values set for the motor protection (L1-01, L1-02) as well as the motor rated current (E2-01).</li> <li>• Increase motor capacity.</li> </ul>
The air around the motor is too hot.	<ul style="list-style-type: none"> <li>• Check the ambient temperature.</li> <li>• Cool the area until it is within the specified temperature range.</li> </ul>
Insufficient voltage insulation between motor phases.	<p>When the motor cable is long, high voltage surges occur between the motor coils and drive switching. Normally, surges can reach up to three times the drive input power supply voltage (600 V for 200 V class, and 1200 V for 400 V class).</p> <ul style="list-style-type: none"> <li>• Use a motor with a voltage tolerance higher than the max voltage surge.</li> <li>• Use a motor designed to work specifically with a drive when using a 400 V class unit.</li> <li>• Install an AC reactor on the output side of the drive. The carrier frequency should be set to 2 kHz when installing an AC reactor.</li> </ul>
The motor fan has stopped or is clogged.	Check the motor fan.
Carrier frequency is too low.	Increase the carrier frequency to lower the current harmonic distortion and lower motor temperature.

### ◆ Drive Does Not Allow Selection the Desired Auto-Tuning Mode

Cause	Possible Solutions
The desired Auto-Tuning mode is not available for the selected control mode.	<ul style="list-style-type: none"> <li>• Check if the desired tuning mode is available for the selected control mode. Refer to <a href="#">Auto-Tuning on page 113</a>.</li> <li>• Change the motor control method by setting A1-02.</li> </ul>

### ◆ oPE02 Error Occurs When Lowering the Motor Rated Current Setting

Cause	Possible Solutions
Motor rated current and the motor no-load current setting in the drive are incorrect.	<ul style="list-style-type: none"> <li>• The user is trying to set the motor rated current in E2-01 to a value lower than the no-load current set in E2-03.</li> <li>• Make sure that value set in E2-01 is higher than E2-03.</li> <li>• If it is necessary to set E2-01 lower than E2-03, first lower the value set to E2-03, then change the setting in E2-01 as needed.</li> </ul>

### ◆ Motor Stalls during Acceleration or Acceleration Time is Too Long

Cause	Possible Solutions
Current suppression keeps the drive from accelerating.	<p>Take the following steps to resolve the problem:</p> <ul style="list-style-type: none"> <li>• Reduce the load.</li> <li>• Increase motor capacity.</li> </ul> <p><b>Note:</b> Although the drive has a Stall Prevention function and a Torque Compensation Limit function, accelerating too quickly or trying to drive an excessively large load can exceed the capabilities of the motor.</p>
Load is too heavy.	
Frequency reference is too low.	<ul style="list-style-type: none"> <li>• Check the maximum output frequency (E1-04).</li> <li>• Increase E1-04 if it is set too low.</li> </ul> <p>Check U1-01 for proper frequency reference.</p> <p>Check if a frequency reference signal switch has been set to one of the multi-function input terminals.</p> <p>Check for low gain level set to terminals A1, A2, or A3 (H3-03, H3-11, H3-07).</p>
Load is too heavy.	<ul style="list-style-type: none"> <li>• Reduce the load so that the output current remains within the motor rated current.</li> <li>• In extruder and mixer applications, the load will sometimes increase as the temperature drops.</li> <li>• Increase the acceleration time.</li> <li>• Check if the mechanical brake is fully releasing as it should.</li> </ul>
Acceleration time has been set too long.	Check if the acceleration time parameters have been set too long (C1-01, C1-03).
Motor characteristics and drive parameter settings are incompatible with one another.	<ul style="list-style-type: none"> <li>• Set the correct V/f pattern so that it matches the characteristics of the motor being used.</li> <li>• Check the V/f pattern set to E1-03.</li> <li>• Execute Rotational Auto-Tuning.</li> </ul>

## 6.10 Troubleshooting without Fault Display

Cause	Possible Solutions
Incorrect frequency reference setting.	<ul style="list-style-type: none"> <li>Check the multi-function analog input settings. Multi-function analog input terminal A1, A2, or A3 is set for frequency gain (H3-02, H3-10, or H3-06 is set to "1"), but there is no voltage or current input provided.</li> <li>Make sure H3-02, H3-10, and H3-06 are set to the proper values.</li> <li>See if the analog input value is set to the right value (U1-13 to U1-15).</li> </ul>
The Stall Prevention level during acceleration and deceleration set too low.	<ul style="list-style-type: none"> <li>Check the Stall Prevention level during acceleration (L3-02).</li> <li>If L3-02 is set too low, acceleration may be taking too long.</li> <li>Increase L3-02.</li> </ul>
The Stall Prevention level during run has been set too low.	<ul style="list-style-type: none"> <li>Check the Stall Prevention level during run (L3-06).</li> <li>If L3-06 is set too low, speed will drop as the drive outputs torque.</li> <li>Increase the setting value.</li> </ul>
Drive reached the limitations of the V/f motor control method.	<ul style="list-style-type: none"> <li>The motor cable may be long enough (over 50 m) to require Auto-Tuning for line-to-line resistance.</li> <li>Be aware that V/f Control is comparatively limited when it comes to producing torque at low speeds.</li> <li>Consider switching to Open Loop Vector Control.</li> </ul>

### ◆ Drive Frequency Reference Differs from the Controller Frequency Reference Command

Cause	Possible Solutions
The analog input gain and bias for the frequency reference input are set to incorrect values.	<ul style="list-style-type: none"> <li>Check the gain and bias settings for the analog inputs that are used to set the frequency reference. Check parameters H3-03 and H3-04 for input A1, check parameters H3-11 and H3-12 for input A2, and check parameters H3-07 and H3-08 for input A3.</li> <li>Set these parameters to the appropriate values.</li> </ul>
A frequency bias signal is being entered via analog input terminals A1 to A3.	<ul style="list-style-type: none"> <li>If more than one of multi-function analog inputs A1 to A3 is set for frequency reference bias (H3-02, H3-10, or H3-06 is set to "0"), then the sum of all signals builds the frequency reference.</li> <li>Make sure that H3-02, H3-10, and H3-06 are set appropriately.</li> <li>Check the input level set for terminals A1 to A3 (U1-13 to U1-15).</li> </ul>
PI control is enabled, and the drive is consequently adjusting the output frequency to match the PI setpoint. The drive will only accelerate to the maximum output frequency set in E1-04 while PI control is active.	If PI control is not necessary for the application, disable it by setting b5-01 to "0".

### ◆ Excessive Motor Oscillation and Erratic Rotation

Cause	Possible Solutions
Poor balance between motor phases.	Check drive input power voltage to ensure that it provides stable power.
Hunting prevention function is disabled.	Enable Hunting Prevention (n1-01 = 1).

### ◆ Deceleration Takes Longer Than Expected with Dynamic Braking Enabled

Cause	Possible Solutions
L3-04 is set incorrectly.	<ul style="list-style-type: none"> <li>Check the Stall Prevention level during deceleration (L3-04).</li> <li>If a dynamic braking option has been installed, disable Stall Prevention during deceleration (L3-04 = 0).</li> </ul>
The deceleration time is set too long.	Set deceleration to more appropriate time (C1-02).
Insufficient motor torque.	<ul style="list-style-type: none"> <li>Assuming parameter settings are normal and that no overvoltage occurs when there is insufficient torque, it is likely that the demand on the motor has exceeded the motor capacity.</li> <li>Use a larger motor.</li> </ul>
Reaching the torque limit.	<ul style="list-style-type: none"> <li>If multi-function analog input terminal A1, A2, or A3 is set to torque limit (H3-02, H3-10, or H3-06 equals 10, 11, 12, or 15), ensure that the analog input levels are set to the correct levels.</li> <li>Ensure H3-02, H3-10, and H3-06 are set to the right levels.</li> <li>Ensure the analog input is set to the correct value (U1-13 to U1-15).</li> </ul>
Load exceeded the internal torque limit determined by the drive rated current.	Switch to a larger capacity drive.

### ◆ Noise From Drive or Motor Cables When the Drive is Powered On

Cause	Possible Solutions
Relay switching in the drive generates excessive noise.	<ul style="list-style-type: none"> <li>Lower the carrier frequency (C6-02).</li> <li>Install a noise filter on the input side of drive input power.</li> <li>Install a noise filter on the output side of the drive.</li> <li>Place the wiring inside a metal conduit to shield it from switching noise.</li> <li>Ground the drive and motor properly.</li> <li>Separate the main circuit wiring and the control lines.</li> <li>Make sure wires and the motor have been properly grounded.</li> </ul>

### ◆ Earth Leakage Circuit Breaker (ELCB) Trips During Run

Cause	Possible Solutions
Excessive leakage current trips ELCB.	<ul style="list-style-type: none"> <li>Increase the ELCB sensitivity or use ELCB with a higher threshold.</li> <li>Lower the carrier frequency (C6-02).</li> <li>Reduce the length of the cable used between the drive and the motor.</li> <li>Install a noise filter or reactor on the output side of the drive. Set the carrier frequency to 2 kHz when connecting a reactor.</li> </ul>

## ◆ Connected Machinery Vibrates When Motor Rotates

### ■ Unexpected Noise from Connected Machinery

Cause	Possible Solutions
The carrier frequency is at the resonant frequency of the connected machinery.	Adjust the carrier frequency using parameters C6-02 through C6-05.
The drive output frequency is the same as the resonant frequency of the connected machinery.	<ul style="list-style-type: none"> <li>Adjust the parameters used for the Jump frequency function (d3-01 through d3-04) to skip the problem-causing bandwidth.</li> <li>Place the motor on a rubber pad to reduce vibration.</li> </ul>

**Note:** The drive may have trouble assessing the status of the load due to white noise generated from using Swing PWM (C6-02 = 7 to A).

### ■ Oscillation or Hunting

Cause	Possible Solutions
Insufficient tuning.	Perform Auto-Tuning. Refer to <a href="#">Motor Performance Fine-Tuning on page 258</a> .
Gain is too low when using PI control.	Refer to <a href="#">b5: PI Control on page 145</a> for details.
The frequency reference is assigned to an external source and the signal is noisy.	<ul style="list-style-type: none"> <li>Ensure that noise is not affecting the signal lines.</li> <li>Separate main circuit wiring and control circuit wiring.</li> <li>Use twisted-pair cables or shielded wiring for the control circuit.</li> <li>Increase the analog input time filter constant (H3-13).</li> </ul>
The cable between the drive and motor is too long.	<ul style="list-style-type: none"> <li>Perform Auto-Tuning.</li> <li>Reduce the length of the cable.</li> </ul>

## ◆ PI Output Fault

Cause	Possible Solutions
No PI feedback input.	<ul style="list-style-type: none"> <li>Check the multi-function analog input terminal settings.</li> <li>Set multi-function analog input terminal A1, A2, or A3 for PI feedback (H3-02, H3-10, or H3-06 = "B").</li> <li>A signal input to the terminal selection for PI feedback is needed.</li> <li>Check the connection of the feedback signal.</li> <li>Check the various PI-related parameter settings.</li> <li>No PI feedback input to the terminal causes the value detected to be 0, causing a PI fault and the drive to operate at max frequency.</li> </ul>
The level of detection and the target value do not correspond with each other.	<ul style="list-style-type: none"> <li>PI control keeps the difference between target and detection values at 0. Set the input level for the values relative to one another.</li> <li>Use analog input gains H3-03 and H3-11 to adjust PI target and feedback signal scaling.</li> </ul>
Reverse drive output frequency and speed detection. When output frequency rises, the sensor detects a speed decrease.	Set PI output for reverse characteristics (b5-09 = 1).
Adjustment made to PI parameter settings are insufficient.	Refer to <a href="#">b5: PI Control on page 145</a> for details.

## ◆ Motor Rotates After the Drive Output is Shut Off (Motor Rotates During DC Injection Braking)

Cause	Possible Solutions
DC Injection Braking is set too low and the drive cannot decelerate properly.	<ul style="list-style-type: none"> <li>Adjust the DC Injection braking settings.</li> <li>Increase the current level for DC Injection Braking (b2-02).</li> <li>Increase the DC Injection Braking time at stop (b2-04).</li> </ul>
The stopping method is set so that the drive coasts to stop.	Set b1-03 (Stopping Method Selection) to 0 or 2.

## ◆ Output Frequency is not as High as Frequency Reference

Cause	Possible Solutions
Frequency reference is set within the range of the Jump frequency.	<ul style="list-style-type: none"> <li>Adjust the parameters used for the Jump frequency function (d3-01, d3-02, d3-03).</li> <li>Enabling the Jump frequency prevents the drive from outputting the frequencies specified in the Jump range.</li> </ul>
Upper limit for the frequency reference has been exceeded.	<ul style="list-style-type: none"> <li>Set the maximum output frequency and the upper limit for the frequency reference to more appropriate values (E1-04, d2-01).</li> <li>The following calculation yields the upper value for the output frequency = <math>E1-04 \times d2-01 / 100</math></li> </ul>
Large load triggered Stall Prevention function during acceleration.	<ul style="list-style-type: none"> <li>Reduce the load.</li> <li>Adjust the Stall Prevention level during acceleration (L3-02).</li> </ul>

## ◆ Buzzing Sound from Motor at 2 kHz

Cause	Possible Solutions
Exceeded 110% of the rated output current of the drive while operating at low speeds.	<ul style="list-style-type: none"> <li>If the output current rises too high at low speeds, the carrier frequency is automatically reduced and causes a whining or buzzing sound.</li> <li>If the sound is coming from the motor, disable carrier frequency derating (L8-38 = 0).</li> <li>Disabling the automatic carrier frequency derating increases the chances of an overload fault (oL2). Switch to a larger capacity motor if oL2 faults occur too frequently.</li> </ul>

## 6.10 Troubleshooting without Fault Display

### ◆ Unstable Motor Speed when Using PM

Cause	Possible Solutions
The motor code for the PM motor (E5-01 or T2-02) is set incorrectly (Yaskawa motors only).	Refer to <i>Motor Performance Fine-Tuning on page 258</i> for details.
Drive is attempting to operate the motor beyond the speed control range listed in the specifications.	Check the speed control range and adjust the speed accordingly.
Motor hunting occurs.	Refer to <i>Motor Performance Fine-Tuning on page 258</i> for details.
Hunting occurs at start.	Increase the S-curve time at the start of acceleration (C2-01).
Too much current is flowing through the drive.	<ul style="list-style-type: none"><li>• Enter the correct motor code for the PM motor being used into E5-01.</li><li>• For special-purpose motors, enter the correct data to all E5 parameters according to the test report provided for the motor.</li></ul>

### ◆ Motor Does Not Restart after Power Loss

Cause	Possible Solutions
The Run command was not issued again when power was restored.	<ul style="list-style-type: none"><li>• Check the sequence and wiring that has been set up to enter the Run command.</li><li>• A relay should be set up to make sure the Run command remains enabled throughout any power loss.</li></ul>
The relay that is supposed to maintain the Run command has been switched off.	Check wiring and circuitry for the relay intended to keep the Run command enabled.

# Periodic Inspection & Maintenance

---

This chapter describes the periodic inspection and maintenance of the drive to ensure that it receives the proper care to maintain overall performance.

<b>7.1 SECTION SAFETY</b> .....	<b>296</b>
<b>7.2 INSPECTION</b> .....	<b>299</b>
<b>7.3 PERIODIC MAINTENANCE</b> .....	<b>301</b>
<b>7.4 COOLING FAN AND CIRCULATION FAN</b> .....	<b>303</b>
<b>7.5 REPLACING THE AIR FILTER</b> .....	<b>325</b>
<b>7.6 DRIVE REPLACEMENT</b> .....	<b>327</b>

## 7.1 Section Safety

### DANGER

#### Electrical Shock Hazard

**Do not connect or disconnect wiring while the power is on.**

Failure to comply will result in death or serious injury.

Before servicing, disconnect all power to the equipment. The internal capacitor remains charged even after the power supply is turned off. The charge indicator LED will extinguish when the DC bus voltage is below 50 Vdc. To prevent electric shock, wait for at least the time specified on the warning label once all indicators are OFF, and then measure the DC bus voltage level to confirm it has reached a safe level.

**Never connect or disconnect wiring, remove connectors or option cards, or replace the cooling fan while the power is on.**

Failure to comply will result in death or serious injury.

Before servicing, disconnect all power to the equipment. The internal capacitor remains charged even after the power supply is turned off.

### WARNING

#### Electrical Shock Hazard

**Do not operate equipment with covers removed.**

Failure to comply could result in death or serious injury.

The diagrams in this section may show drives without covers or safety shields to show details. Be sure to reinstall covers or shields before operating the drives and run the drives according to the instructions described in this manual.

**Always ground the motor-side grounding terminal.**

Improper equipment grounding could result in death or serious injury by contacting the motor case.

**Do not remove covers or touch circuit boards while the power is on.**

Failure to comply could result in death or serious injury.

**Do not allow unqualified personnel to perform work on the drive.**

Failure to comply could result in death or serious injury.

Installation, maintenance, inspection, and servicing must be performed only by authorized personnel familiar with installation, adjustment, and maintenance of AC drives.

**Do not perform work on the drive while wearing loose clothing, jewelry or without eye protection.**

Failure to comply could result in death or serious injury.

Remove all metal objects such as watches and rings, secure loose clothing, and wear eye protection before beginning work on the drive.

**Do not touch any terminals before the capacitors have fully discharged.**

Failure to comply could result in death or serious injury.

Before wiring terminals, disconnect all power to the equipment. The internal capacitor remains charged even after the power supply is turned off. After shutting off the power, wait for at least the amount of time specified on the drive before touching any components.



**⚠ WARNING****Fire Hazard**

**Tighten all terminal screws to the specified tightening torque.**

Loose electrical connections could result in death or serious injury by fire due to overheating of electrical connections.

**Do not use an improper voltage source.**

Failure to comply could result in death or serious injury by fire.

Verify that the rated voltage of the drive matches the voltage of the incoming power supply before applying power.

**Do not use improper combustible materials.**

Failure to comply could result in death or serious injury by fire.

Attach the drive to metal or other noncombustible material.

**NOTICE**

**Observe proper electrostatic discharge procedures (ESD) when handling the drive and circuit boards.**

Failure to comply may result in ESD damage to the drive circuitry.

**Follow cooling fan replacement instructions. The cooling fan cannot operate properly when it is installed incorrectly and could seriously damage the drive.**

Follow the instructions in this manual to replace the cooling fan, making sure that the label is on top before inserting the cooling fan into the drive. To ensure maximum useful product life, replace both cooling fans when performing maintenance.

**Never connect or disconnect the motor from the drive while the drive is outputting voltage.**

Improper equipment sequencing could result in damage to the drive.

**Do not use unshielded cable for control wiring.**

Failure to comply may cause electrical interference resulting in poor system performance. Use shielded, twisted-pair wires and ground the shield to the ground terminal of the drive.

**Do not allow unqualified personnel to use the product.**

Failure to comply could result in damage to the drive or braking circuit.

Maintenance, inspection, and replacement of parts must be performed only by authorized personnel familiar with installation, adjustment and maintenance of AC drives.

**Do not modify the drive circuitry.**

Failure to comply could result in damage to the drive and will void warranty.

Yaskawa is not responsible for any modification of the product made by the user. This product must not be modified.

**Check all the wiring to ensure that all connections are correct after installing the drive and connecting any other devices.**

Failure to comply could result in damage to the drive.

**Comply with proper wiring practices.**

The motor may run in reverse if the phase order is backward.

Connect motor input terminals U, V and W to drive output terminals U/T1, V/T2, and W/T3. The phase order for the drive and motor should match.

### NOTICE

**Frequently switching the drive power supply to stop and start the motor can damage the drive.**

To get the full performance life out of the electrolytic capacitors and circuit relays, refrain from switching the drive power supply off and on more than once every 30 minutes. Frequent use can damage the drive. Use the drive to stop and start the motor.

**Do not operate damaged equipment.**

Failure to comply could result in further damage to the equipment.

Do not connect or operate any equipment with visible damage or missing parts.

## 7.2 Inspection

Power electronics have limited life and may exhibit changes in characteristics or performance deterioration after years of use under normal conditions. To help avoid such problems, it is important to perform preventive maintenance and periodic inspection on the drive.

Drives contain a variety of power electronics such as power transistors, semiconductors, capacitors, resistors, fans, and relays. The electronics in the drive serve a critical role in maintaining proper motor control.

Follow the inspection lists provided in this chapter as a part of a regular maintenance program.

**Note:** The drive will require more frequent inspection if it is placed in harsh environments, such as:

- High ambient temperatures
- Frequent starting and stopping
- Fluctuations in the AC supply or load
- Excessive vibrations or shock loading
- Dust, metal dust, salt, sulfuric acid, chlorine atmospheres
- Poor storage conditions.

Perform the first equipment inspection one to two years after installation.

### ◆ Recommended Daily Inspection

**Table 7.1** outlines the recommended daily inspection for Yaskawa drives. Check the following items on a daily basis to avoid premature deterioration in performance or product failure. Copy this checklist and mark the “Checked” column after each inspection.

**Table 7.1 General Recommended Daily Inspection Checklist**

Inspection Category	Inspection Points	Corrective Action	Checked
Motor	Inspect for abnormal oscillation or noise coming from the motor.	<ul style="list-style-type: none"> <li>• Check the load coupling.</li> <li>• Measure motor vibration.</li> <li>• Tighten all loose components.</li> </ul>	
Cooling	Inspect for abnormal heat generated from the drive or motor and visible discoloration.	<ul style="list-style-type: none"> <li>• Check for excessive load.</li> <li>• Loose connections</li> <li>• Check for dirty heatsink or motor.</li> <li>• Ambient temperature</li> </ul>	
	Inspect drive cooling fan and circulation fan operation.	<ul style="list-style-type: none"> <li>• Check for clogged or dirty fan.</li> <li>• Check fan operation drive parameter.</li> </ul>	
	Inspect drive airfilter.	Check for the dirty airfilter.	
Environment	Verify the drive environment complies with the specifications listed in <i>Installation Environment on page 44</i> .	Eliminate the source of contaminants or correct poor environment.	
Load	The drive output current should not be higher than the motor or drive rating for an extended period of time.	<ul style="list-style-type: none"> <li>• Check for excessive load.</li> <li>• Check the motor parameter settings of the drive.</li> </ul>	
Power Supply Voltage	Check main power supply and control voltages.	<ul style="list-style-type: none"> <li>• Correct the voltage or power supply to within nameplate specifications.</li> <li>• Verify all main circuit phases.</li> </ul>	

## 7.2 Inspection

### ◆ Recommended Periodic Inspection

**Table 7.2** outlines the recommended periodic inspections for Yaskawa drive installations. Although periodic inspections should generally be performed once a year; the drive may require more frequent inspection in harsh environments or with rigorous use. Operating and environmental conditions, along with experience in each application, will determine the actual inspection frequency for each installation. Periodic inspection will help to avoid premature deterioration in performance or product failure. Copy this checklist and mark the “Checked” column after each inspection.

### ■ Periodic Inspection

**WARNING! Electrical Shock Hazard.** Do not inspect, connect, or disconnect any wiring while the power is on. Failure to comply can result in serious personal injury. Before servicing the drive, disconnect all power to the equipment. The internal capacitor remains charged even after the power supply is turned off. After shutting off the power, wait for at least the amount of time specified on the drive before touching any components.

**Table 7.2 Periodic Inspection Checklist**

Inspection Area	Inspection Points	Corrective Action	Checked
<b>Main Circuit Periodic Inspection</b>			
General	<ul style="list-style-type: none"> <li>Inspect equipment for discoloration from overheating or deterioration.</li> <li>Inspect for damaged or deformed parts.</li> </ul>	<ul style="list-style-type: none"> <li>Replace damaged components as required.</li> <li>The drive has few serviceable parts and may require complete drive replacement.</li> </ul>	
	Inspect for dirt, foreign particles, or dust collection on components.	<ul style="list-style-type: none"> <li>Inspect enclosure door seal if used.</li> <li>Use dry air to clear away foreign matter. Use a pressure of <math>39.2 \times 10^4</math> to <math>58.8 \times 10^4</math> Pa (4 - 6 kg·cm<sup>2</sup>).</li> <li>Replace components if cleaning is not possible.</li> </ul>	
Conductors and Wiring	<ul style="list-style-type: none"> <li>Inspect wiring and connections for discoloration, damage, or heat stress.</li> <li>Inspect wire insulation and shielding for wear.</li> </ul>	Repair or replace damaged wiring.	
Terminals	Inspect terminals for stripped, damaged, or loose connections.	Tighten loose screws and replace damaged screws or terminals.	
Relays and Contactors	<ul style="list-style-type: none"> <li>Inspect contactors and relays for excessive noise during operation.</li> <li>Inspect coils for signs of overheating such as melted or cracked insulation.</li> </ul>	<ul style="list-style-type: none"> <li>Check coil voltage for over or under voltage conditions.</li> <li>Replace damaged removable relays contactors or circuit board.</li> </ul>	
Braking Resistors	Inspect for discoloration of heat stress on or around resistors.	<ul style="list-style-type: none"> <li>Minor discoloration may be acceptable.</li> <li>If discoloration exists check for loose connections.</li> </ul>	
Electrolytic Capacitor	<ul style="list-style-type: none"> <li>Inspect for leaking, discoloration, or cracks.</li> <li>Check if the cap has come off, for any swelling, or if the sides have burst open.</li> </ul>	The drive has few serviceable parts and may require complete drive replacement.	
Diode, IGBT (Power Transistor)	Inspect for dust or other foreign material collected on the surface.	Use dry air to clear away foreign matter. Use a pressure of $39.2 \times 10^4$ to $58.8 \times 10^4$ Pa (4 - 6 kg·cm <sup>2</sup> ).	
<b>Motor Periodic Inspection</b>			
Operation Check	Check for increased vibration or abnormal noise.	Stop the motor and contact qualified maintenance personnel as required.	
<b>Control Circuit Periodic Inspection</b>			
General	<ul style="list-style-type: none"> <li>Inspect terminals for stripped, damaged, or loose connections.</li> <li>Make sure all terminals have been properly tightened.</li> </ul>	<ul style="list-style-type: none"> <li>Tighten loose screws and replace damaged screws or terminals.</li> <li>If terminals are integral to a circuit board, then board or drive replacement may be required.</li> </ul>	
	Check for any odor, discoloration, and rust. Make sure connections are properly fastened and that no dust or oil mist has accumulated on the surface of the board.	<ul style="list-style-type: none"> <li>Fix any loose connections.</li> <li>If an antistatic cloth or vacuum plunger can't be used, replace the board.</li> <li>Do not use any solvents to clean the board.</li> <li>Use dry air to clear away foreign matter. Use a pressure of <math>39.2 \times 10^4</math> to <math>58.8 \times 10^4</math> Pa (4 - 6 kg·cm<sup>2</sup>).</li> <li>The drive has few serviceable parts and may require complete drive replacement.</li> </ul>	
<b>Cooling System Periodic Inspection</b>			
Air filter	Check for dirty or clogged filter.	Replace the air filter. <i>Refer to Replacing the Air Filter on page 325</i> for detail.	
Cooling Fan, Circulation Fan	<ul style="list-style-type: none"> <li>Check for abnormal oscillation or unusual noise.</li> <li>Check for damaged or missing fan blades.</li> </ul>	Replace as required. <i>Refer to Cooling Fan and Circulation Fan on page 303</i> for information on cleaning or replacing the fan.	
Heatsink	Inspect for dust or other foreign material collected on the surface.	Use dry air to clear away foreign matter. Use a pressure of $39.2 \times 10^4$ to $58.8 \times 10^4$ Pa (4 - 6 kg·cm <sup>2</sup> ).	
Air Duct	Inspect air intake and exhaust openings. They must be free from obstruction and properly installed.	<ul style="list-style-type: none"> <li>Visually inspect the area.</li> <li>Clear obstructions and clean air duct as required.</li> </ul>	
<b>Display Periodic Inspection</b>			
Digital Operator	<ul style="list-style-type: none"> <li>Make sure data appears on the operator properly.</li> <li>Inspect for dust or other foreign material that may have collected on surrounding components.</li> </ul>	<ul style="list-style-type: none"> <li>Contact your Yaskawa representative if there is any trouble with the display or keypad.</li> <li>Clean the digital operator.</li> </ul>	

## 7.3 Periodic Maintenance

The drive has Maintenance Monitors that keep track of component wear. This feature provides advance maintenance warning and eliminates the need to shut down the entire system for unexpected problems. The drive allows the user to check predicted maintenance periods for the components listed below.

- Cooling Fan, Circulation Fan
- Electrolytic Capacitors
- Inrush Prevention Circuit
- IGBTs

For replacement parts, contact the distributor where the drive was purchased or contact Yaskawa directly.

### ◆ Replacement Parts

**Table 7.3** contains the estimated performance life of components that require replacement during the life of the drive. Only use Yaskawa replacement parts for the appropriate drive model and revision.

**Table 7.3 Estimated Performance Life**

Component	Estimated Performance Life
Cooling Fan, Circulation Fan	10 years
Electrolytic Capacitors	10 years <I>

<I> The drive has few serviceable parts and may require complete drive replacement.

**NOTICE:** *Estimated performance life based on specific usage conditions. These conditions are provided for the purpose of replacing parts to maintain performance. Some parts may require more frequent replacement due to poor environments or rigorous use. Usage conditions for estimated performance life:*

- Ambient temperature: Yearly average of 40°C (IP00 enclosure)
- Load factor: 80% maximum
- Operation time: 24 hours a day

### ■ Performance Life Monitors Maintenance Monitors

The drive calculates the maintenance period for components that may require replacement during the life of the drive. A percentage of the maintenance period is displayed on the digital operator by viewing the appropriate monitor parameter.

When the maintenance period reaches 100%, there is increased risk that the drive may malfunction. Yaskawa recommends checking the maintenance period regularly to ensure maximum performance life.

*Refer to Recommended Periodic Inspection on page 300* for more details.

**Table 7.4 Performance Life Monitors Used for Component Replacement**

Parameter	Component	Contents
U4-03	Cooling Fan, Circulation Fan	Displays the accumulated operation time of the fan, from 0 to 99999 hours. This value is automatically reset to 0 once it reaches 99999.
U4-04		Displays the accumulated fan operation time as a percentage of the specified maintenance period.
U4-05	DC Bus Capacitors	Displays the accumulated time the capacitors are used as a percentage of the specified maintenance period.
U4-06	Inrush (pre-charge) Relay	Displays the number of times the drive is powered up as a percentage of the performance life of the inrush circuit.
U4-07	IGBT	Displays the percentage of the maintenance period reached by the IGBTs.

### ■ Alarm Outputs for Maintenance Monitors

An output can be set up to inform the user when a specific components has neared its expected performance life.

When one of multi-function digital output terminals has been assigned the maintenance monitor function (H2-□□ = 2F), the terminal will close when the cooling fan, DC bus capacitors, or DC bus pre-charge relay reach 90% of the expected performance life, or the IGBTs have reached 50% of their expect performance life. Additionally the digital operator will display an alarm like shown in **Table 7.5** to indicate the specific components that may need maintenance.

## 7.3 Periodic Maintenance

**Table 7.5 Maintenance Alarms**

Alarm Display		Function	Corrective Action
LT-1 <1>	LT-1	The cooling fans have reached 90% of their designated life time.	Replace the cooling fan.
LT-2 <2>	LT-2	The DC bus capacitors have reached 90% of their designated life time.	Contact a Yaskawa representative or the nearest Yaskawa sales office on possible drive replacement.
LT-3 <2>	LT-3	The DC bus charge circuit has reached 90% of its designated life time.	Contact a Yaskawa representative or the nearest Yaskawa sales office on possible drive replacement.
LT-4 <2>	LT-4	The IGBT's have reached 50% of their designated life time.	Check the load, carrier frequency, and output frequency.
TrPC <2>	TrPC	The IGBT's have reached 90% of their designated life time.	Contact a Yaskawa representative or the nearest Yaskawa sales office on possible drive replacement.

<1> This alarm message will be output only if the Maintenance Monitor function is assigned to one of the digital outputs (H2-□□ = 2F). The alarm will also trigger a digital output that is programmed for alarm indication (H2-□□ = 10).

<2> This alarm message will always be output, even if the Maintenance Monitor function is not assigned to any of the digital outputs (H2-□□ = 2F). The alarm will also trigger a digital output that is programmed for alarm indication (H2-□□ = 10).

### ■ Related Drive Parameters

Parameters o4-03, o4-05, o4-07, and o4-09 can be used to reset a Maintenance Monitor back to zero after a specific component has been replaced. *Refer to Parameter Table on page 360* for details on parameter settings.

**NOTICE:** *If these parameters are not reset after the corresponding parts have been replaced, the Maintenance Monitor function will continue to count down the performance life from the value that was reached with the old part. If the Maintenance Monitor is not reset, the drive will not have the correct value of the performance life for the new component.*

## 7.4 Cooling Fan and Circulation Fan

**NOTICE:** Follow cooling fan replacement instructions. The cooling fan cannot operate properly when installed incorrectly and could seriously damage the drive. To ensure maximum useful product life, replace all cooling fans when performing maintenance.

Contact your Yaskawa representative or the nearest Yaskawa sales office to order replacement cooling fans as required. For drives with multiple cooling fans, replace all the fans when performing maintenance to ensure maximum product performance life.

### ◆ Number of Fan

Three-Phase 200 V Class				Three-Phase 400 V Class					
Model CIMR-E□	Cooling Fan	Circulation Fan	Page	Model CIMR-E□	Cooling Fan	Circulation Fan	Control Board Cooling Fan	Page	
2A0004	–	–	–	4A0002	–	–	–	–	
2A0006	–	–	–	4A0004	–	–	–	–	
2A0008	–	–	–	4A0005	–	–	–	–	
2A0010	–	–	–	4A0007	1	–	–	305	
2A0012	–	–	–	4A0009	1	–	–		
2A0018	1	–	305	4A0011	1	–	–		
2A0021	1	–		4A0018	2	–	–		
2A0030	2	–		4A0023	2	–	–		
2A0040	2	–		4A0031	2	–	–		
2A0056	2	–		4A0038	2	–	–		
2A0069	2	–		4A0044	2	–	–		
2A0081	2	–		4A0058	2	–	–		307
2A0110	2	–		4A0072	2	–	–		309
2A0138	2	–		4A0088	2	–	–		
2A0169	2	–		311	4A0103	2	–	–	
2A0211	2	–	4A0139		2	–	–		
2A0250	2	–	4A0165		2	–	–		
2A0312	2	–	4A0208		2	–	–		
2A0360	3	1	4A0250		3	–	–		
2A0415	3	1	4A0296		3	–	–		
–	–	–	–		4A0362	3	1	–	
–	–	–	–		4A0414	3	1	–	315
–	–	–	–		4A0515	3	2	2	317
–	–	–	–		4A0675	3	2	2	320
–	–	–	–	4A0930	6	4	4		
–	–	–	–	4A1200	6	4	4		

### ◆ Cooling Fan Component Names

**WARNING!** Electrical Shock Hazard. Do not connect or disconnect wiring while the power is on. Failure to comply can result in serious personal injury. Before servicing the drive, disconnect all power to the equipment. The internal capacitor remains charged even after the power supply is turned off. After shutting off the power, wait for at least the amount of time specified on the drive before touching any components.

**CAUTION!** Burn Hazard. Do not touch a hot drive heatsink. Failure to comply could result in minor or moderate injury. Shut off the power to the drive when replacing the cooling fan. To prevent burns, wait at least 15 minutes and ensure the heatsink has cooled down.

## 7.4 Cooling Fan and Circulation Fan

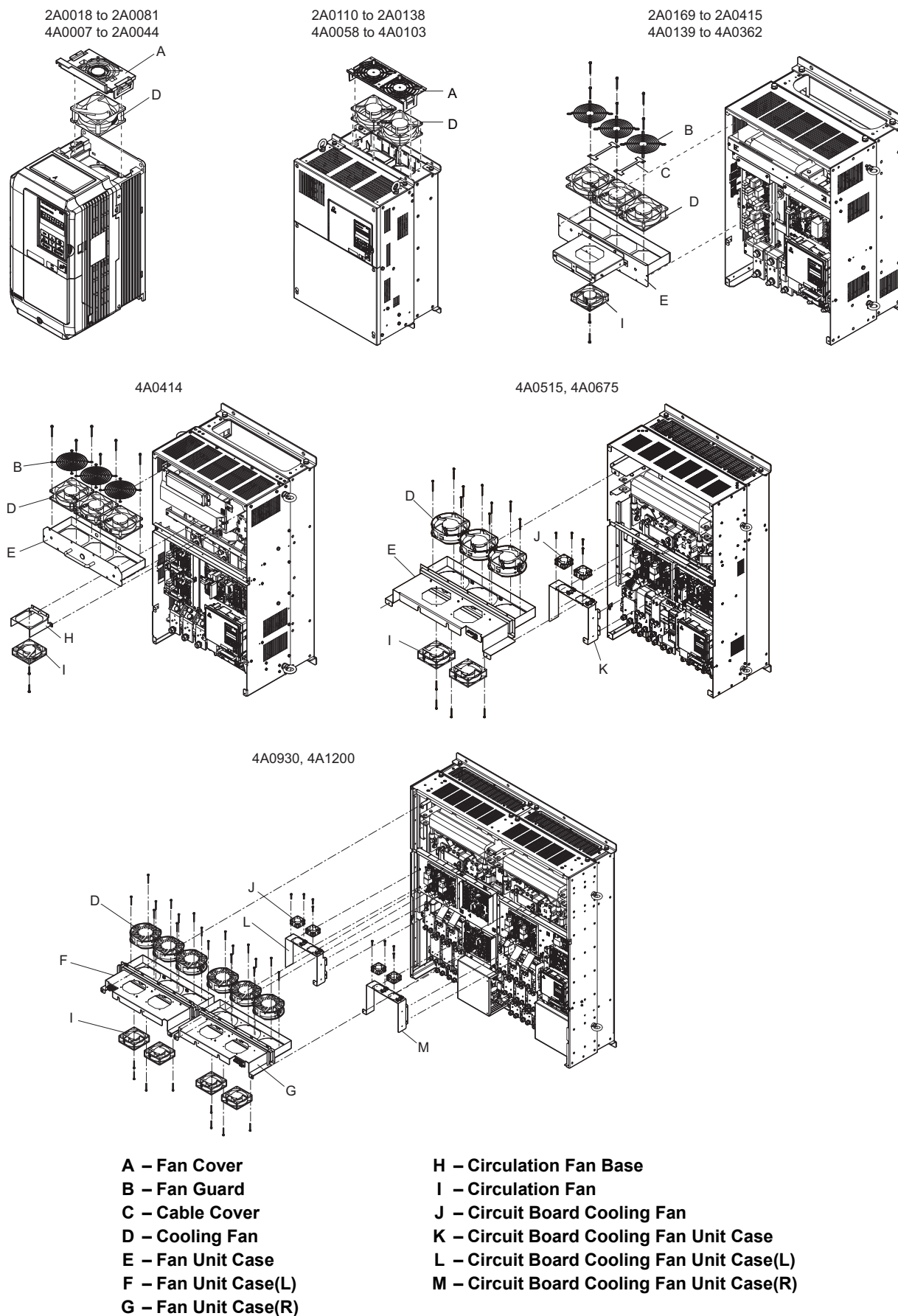


Figure 7.1 Cooling Fan Component Names



## ◆ Cooling Fan Replacement: 2A0018 to 2A0081 and 4A0007 to 4A0044

**WARNING!** *Electrical Shock Hazard. Do not connect or disconnect wiring while the power is on. Failure to comply can result in serious personal injury. Before servicing the drive, disconnect all power to the equipment. The internal capacitor remains charged even after the power supply is turned off. After shutting off the power, wait for at least the amount of time specified on the drive before touching any components.*

**CAUTION!** *Burn Hazard. Do not touch a hot drive heatsink. Failure to comply could result in minor or moderate injury. Shut off the power to the drive when replacing the cooling fan. To prevent burns, wait at least 15 minutes and ensure the heatsink has cooled down.*

**NOTICE:** *Prevent Equipment Damage. Follow cooling fan and circulation fan replacement instructions. Improper fan replacement could result in damage to equipment. When installing the replacement fan into the drive, make sure the fan is facing upwards. To ensure maximum useful product life, replace all fans when performing maintenance.*

### ■ Removing the Cooling Fan

1. Depress the right and left sides of the fan cover hooks and pull upward. Remove the fan cover from the top of the drive.

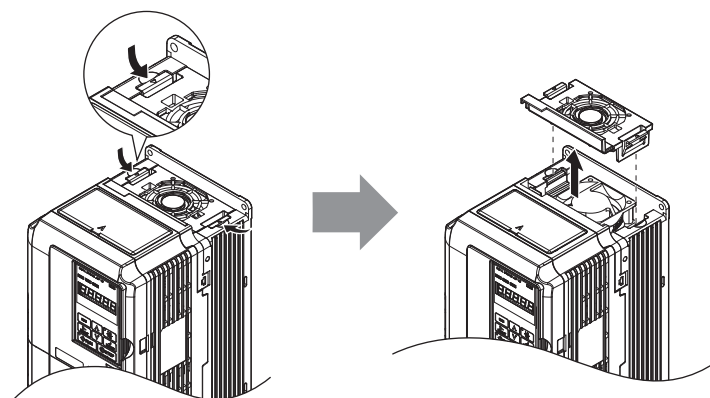


Figure 7.2 Removing the Fan Cover: 2A0018 to 2A0081, 4A0007 to 4A0044

2. Remove the cooling fan cartridge. Disconnect the pluggable connector and remove the fan.

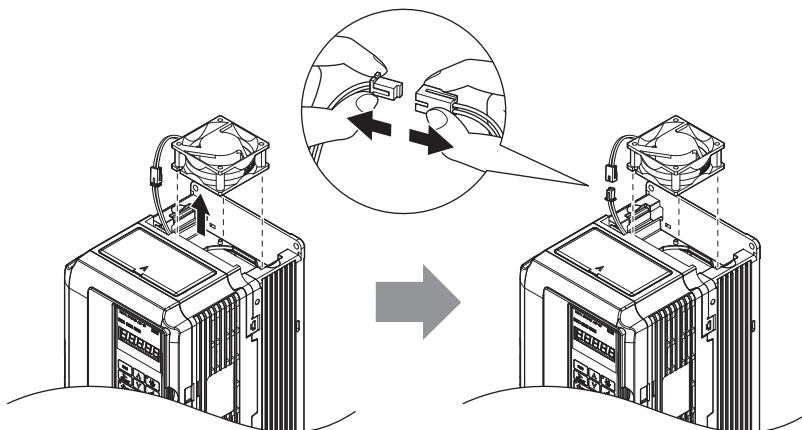
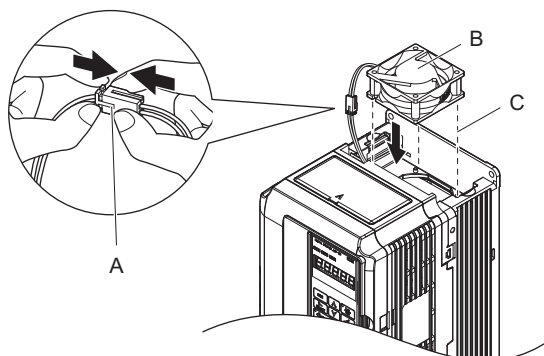


Figure 7.3 Removing the Cooling Fan: 2A0018 to 2A0081, 4A0007 to 4A0044

### ■ Installing the Cooling Fan

Reverse the procedure described above to reinstall the cooling fan.

1. Install the replacement fan into the drive, ensuring the alignment pins line up as shown in the figure below.



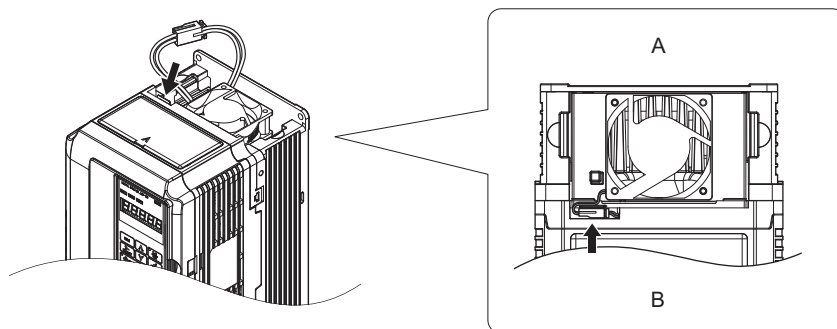
**A** – Push the connectors together so no space remains between them.

**B** – Label facing up

**C** – Make sure the alignment pins line up properly.

**Figure 7.4 Installing the Cooling Fan: 2A0018 to 2A0081, 4A0007 to 4A0044**

2. Make sure the power lines for the fan are properly connected, then place the cable back into the recess of the drive.

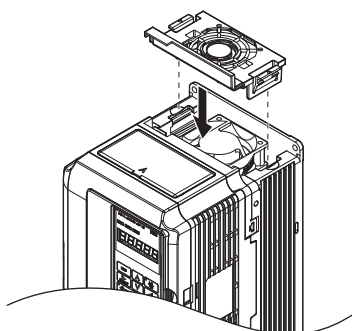


**A** – Back

**B** – Front

**Figure 7.5 Cooling Fan Power Supply Connectors: 2A0018 to 2A0081, 4A0007 to 4A0044**

3. While pressing in on the hooks on the left and right sides of the fan cover, guide the fan cover until it clicks back into place.



**Figure 7.6 Reattach the Fan Cover: 2A0018 to 2A0081, 4A0007 to 4A0044**

4. Turn the power supply back on and reset the cooling fan operation time for the Maintenance Monitor by setting o4-03 to 0.

## ◆ Cooling Fan Replacement: 2A0110 and 2A0138, 4A0058 and 4A0072

**WARNING!** *Electrical Shock Hazard. Do not connect or disconnect wiring while the power is on. Failure to comply can result in serious personal injury. Before servicing the drive, disconnect all power to the equipment. The internal capacitor remains charged even after the power supply is turned off. After shutting off the power, wait for at least the amount of time specified on the drive before touching any components.*

**CAUTION!** *Burn Hazard. Do not touch a hot drive heatsink. Failure to comply could result in minor or moderate injury. Shut off the power to the drive when replacing the cooling fan. To prevent burns, wait at least 15 minutes and ensure the heatsink has cooled down.*

**NOTICE:** *Prevent Equipment Damage. Follow cooling fan and circulation fan replacement instructions. Improper fan replacement could result in damage to equipment. When installing the replacement fan into the drive, make sure the fan is facing upwards. To ensure maximum useful product life, replace all fans when performing maintenance.*

### ■ Removing the Cooling Fan

1. While pressing in on the hooks located on the left and right sides of the fan cover, free the fan cover leading by lifting the back end first.

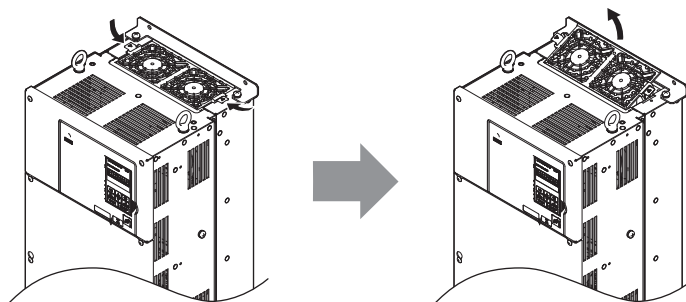


Figure 7.7 Removing the Cooling Fan Cover: 2A0110 and 2A0138, 4A0058 and 4A0072

2. Lift the fan cover out leading with the back end. Unplug the replay connector and free the fan cover from the drive.

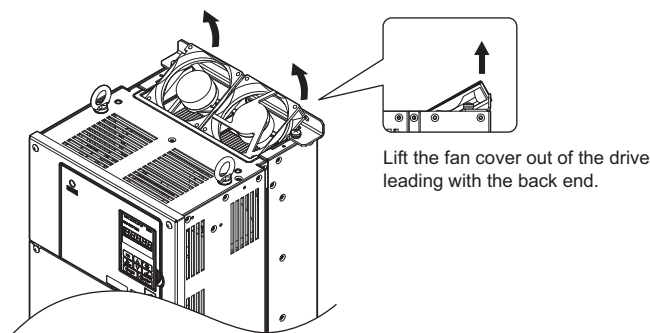
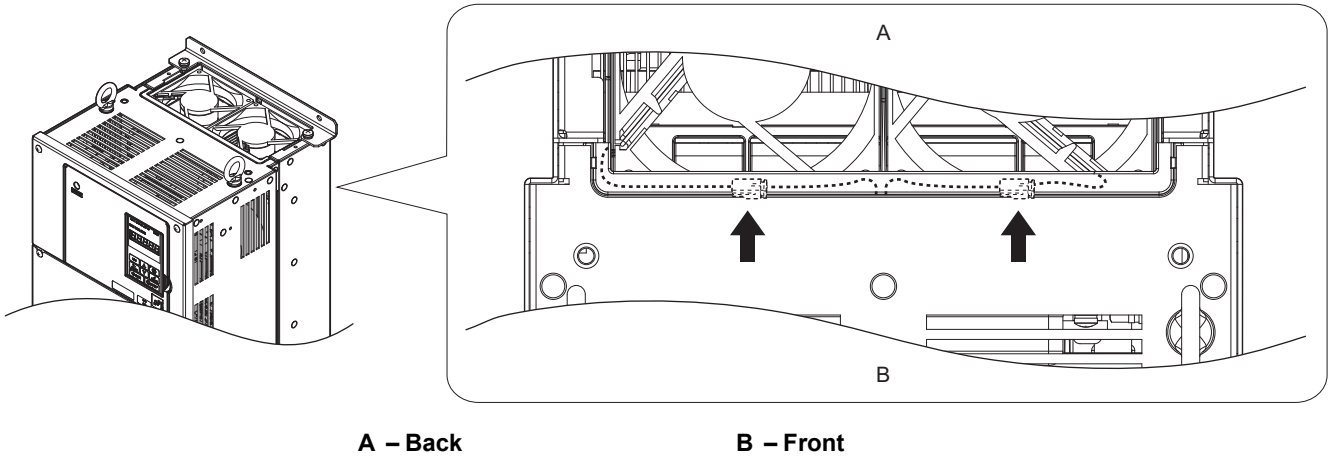


Figure 7.8 Removing the Cooling Fan: 2A0110 and 2A0138, 4A0058 and 4A0072

### ■ Installing the Cooling Fan

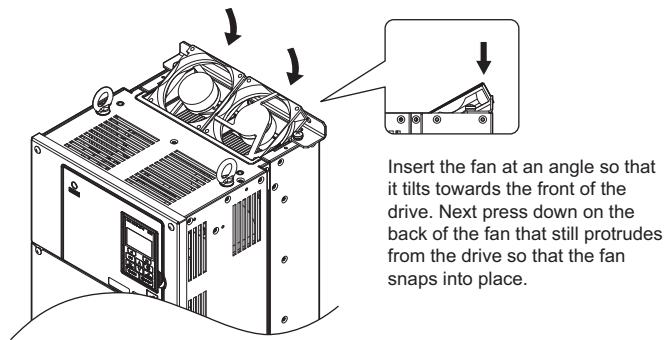
Reverse the procedure described above to reinstall the cooling fan.

1. Make sure the power lines for the fan are properly connected.
2. Place the power supply connectors and cable back into the recess of the drive.



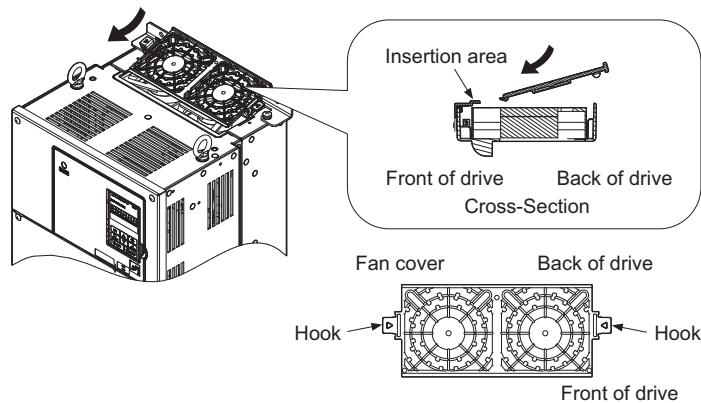
**Figure 7.9 Cooling Fan Power Supply Connectors: 2A0110 and 2A0138, 4A0058 and 4A0072**

3. Install the replacement fan into the drive.



**Figure 7.10 Installing the Cooling Fan: 2A0110 and 2A0138, 4A0058 and 4A0072**

4. Angle the fan cover so the back end tilts up. Slide the cover into the small opening towards the front of the drive, and then guide the entire fan cover into place.



**Figure 7.11 Reattach the Fan Cover: 2A0110 and 2A0138, 4A0058 and 4A0072**

5. While pressing in on the hooks on the left and right sides of the fan cover, guide the fan cover until it clicks back into place.

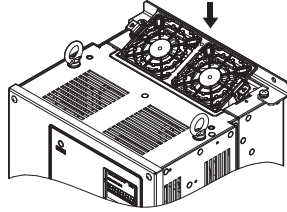


Figure 7.12 Reattach the Fan Cover: 2A0110 and 2A0138, 4A0058 and 4A0072

6. Turn the power supply back on and reset the cooling fan operation time for the Maintenance Monitor by setting o4-03 to 0.

### ◆ Cooling Fan Replacement: 4A0088 and 4A0103

**WARNING!** *Electrical Shock Hazard. Do not connect or disconnect wiring while the power is on. Failure to comply can result in serious personal injury. Before servicing the drive, disconnect all power to the equipment. The internal capacitor remains charged even after the power supply is turned off. After shutting off the power, wait for at least the amount of time specified on the drive before touching any components.*

**CAUTION!** *Burn Hazard. Do not touch a hot drive heatsink. Failure to comply could result in minor or moderate injury. Shut off the power to the drive when replacing the cooling fan. To prevent burns, wait at least 15 minutes and ensure the heatsink has cooled down.*

**NOTICE:** *Prevent Equipment Damage. Follow cooling fan and circulation fan replacement instructions. Improper fan replacement could result in damage to equipment. When installing the replacement fan into the drive, make sure the fan is facing upwards. To ensure maximum useful product life, replace all fans when performing maintenance.*

### ■ Removing the Cooling Fan

1. While pressing in on the hooks located on the left and right sides of the fan cover, free the fan cover leading by lifting the back end first.

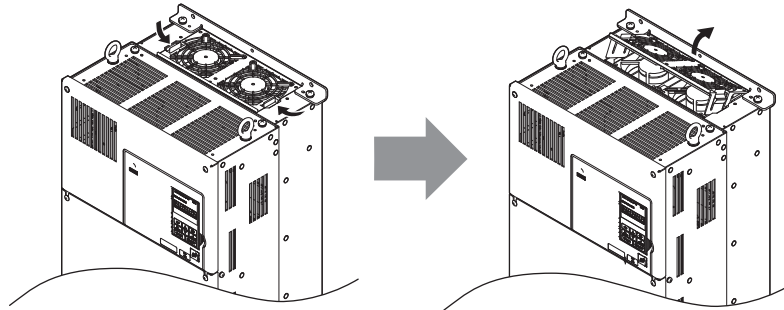


Figure 7.13 Removing the Cooling Fan Cover: 4A0088 and 4A0103

2. Lift the cooling fan directly up on the fan as shown below. Unplug the relay connector and free the fan from the drive.

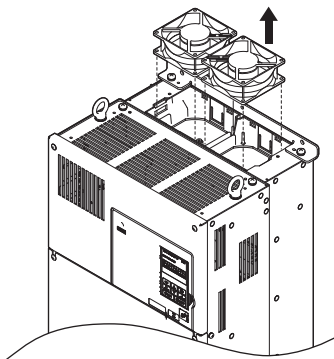


Figure 7.14 Removing the Cooling Fan: 4A0088 and 4A0103

### ■ Installing the Cooling Fan

Reverse the procedure described above to reinstall the cooling fan.

1. Install the replacement fan into the drive, ensuring the alignment pins line up as shown in the figure below.

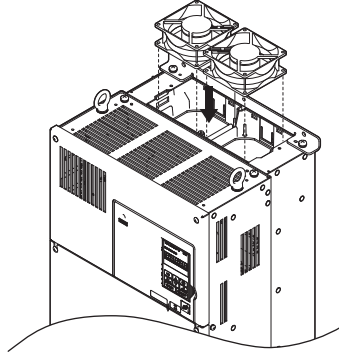
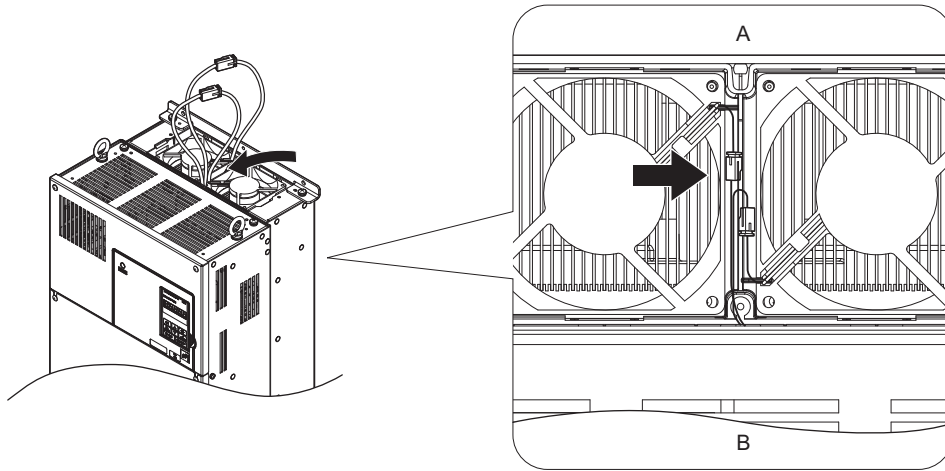


Figure 7.15 Installing the Cooling Fan: 4A0088 and 4A0103

2. Make sure the power lines for the fan are properly connected, then place the power supply connectors and cable back into the recess of the drive.



A – Back

B – Front

Figure 7.16 Cooling Fan Power Supply Connectors: 4A0088 and 4A0103

3. Angle the fan cover as shown and insert the connector tabs into the corresponding holes on the drive.

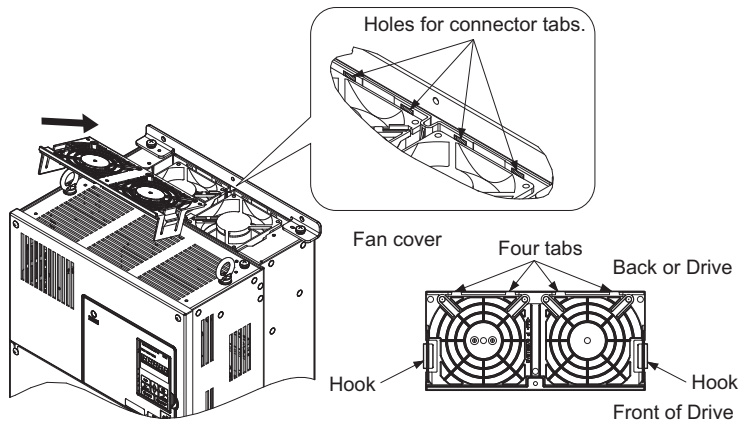


Figure 7.17 Reattach the Fan Cover: 4A0088 and 4A0103

- While pressing in on the hooks on the left and right sides of the fan cover, guide the fan cover until it clicks back into place.

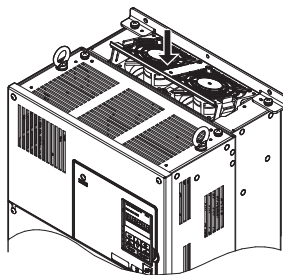


Figure 7.18 Reattach the Fan Cover: 4A0088 and 4A0103

- Turn the power supply back on and reset the cooling fan operation time for the Maintenance Monitor by setting o4-03 to 0.

◆ Cooling Fan Replacement: 2A0169 to 0415, 4A0139 to 4A0362

**WARNING!** *Electrical Shock Hazard. Do not connect or disconnect wiring while the power is on. Failure to comply can result in serious personal injury. Before servicing the drive, disconnect all power to the equipment. The internal capacitor remains charged even after the power supply is turned off. After shutting off the power, wait for at least the amount of time specified on the drive before touching any components.*

**CAUTION!** *Burn Hazard. Do not touch a hot drive heatsink. Failure to comply could result in minor or moderate injury. Shut off the power to the drive when replacing the cooling fan. To prevent burns, wait at least 15 minutes and ensure the heatsink has cooled down.*

**NOTICE:** *Prevent Equipment Damage. Follow cooling fan and circulation fan replacement instructions. Improper fan replacement could result in damage to equipment. When installing the replacement fan into the drive, make sure the fan is facing upwards. To ensure maximum useful product life, replace all fans when performing maintenance.*

■ Removing and Disassembling the Cooling Fan Unit

- Remove the terminal cover and front cover. Refer to [Terminal Cover on page 66](#) for detail.
- Remove the fan connector (CN6). Remove the fan connector (CN6, CN7) in models 2A0360, 2A0415, and 4A0362.

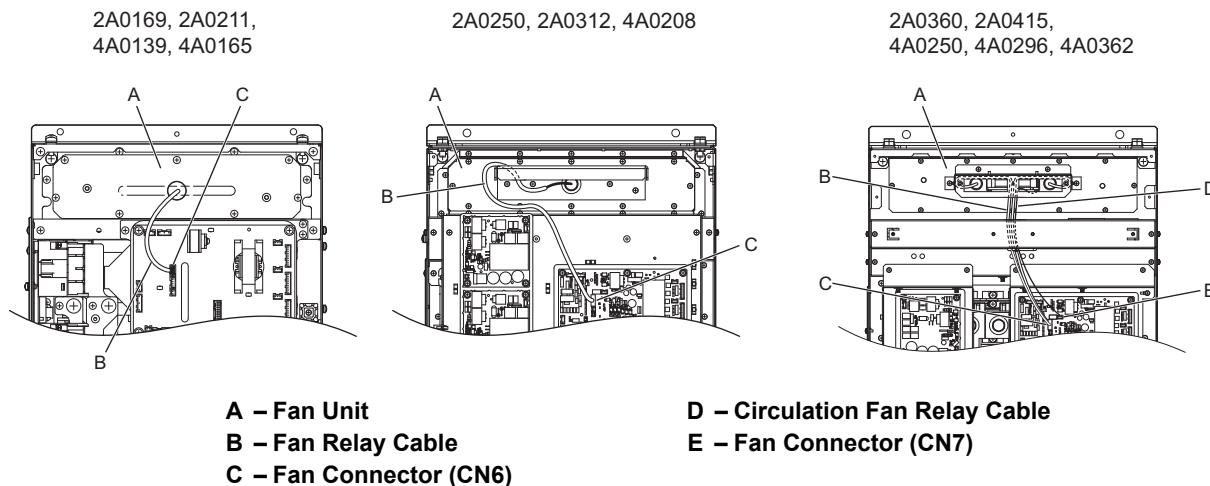


Figure 7.19 Cooling Fan Replacement: Fan Unit and Connectors

## 7.4 Cooling Fan and Circulation Fan

3. Remove the screws holding the fan unit in place and slide the fan unit out of the drive.

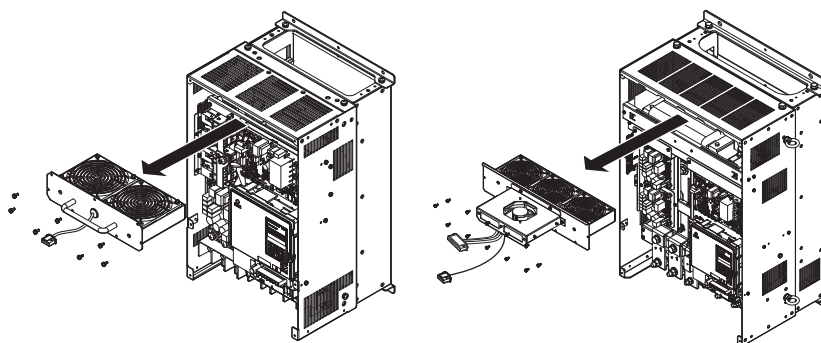


Figure 7.20 Removing the Fan Unit: 2A0169 to 2A0415, 4A0139 to 4A0362

4. Remove the fan guard and replace the cooling fans.

**Note:** Make sure the fan cable does not get pinched between parts when reassembling the fan unit.

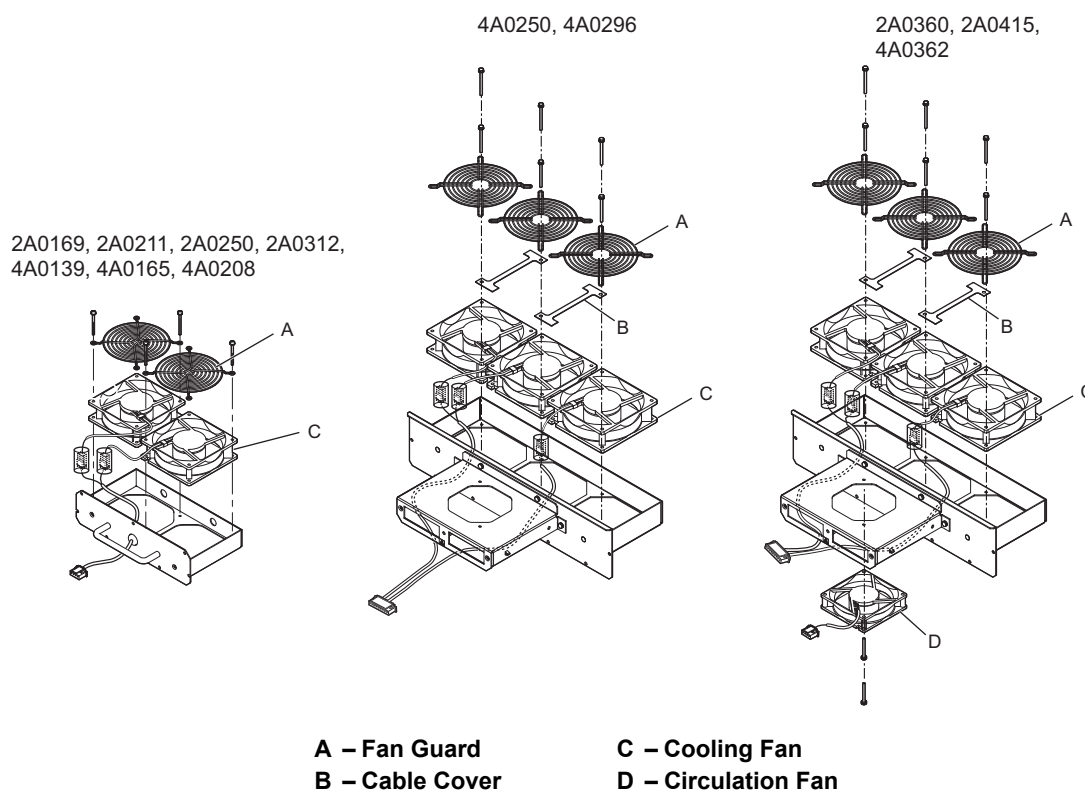
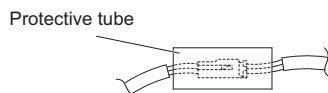


Figure 7.21 Fan Unit Disassembly: 2A0169 to 2A0415, 4A0139 to 4A0362



### ■ Cooling Fan Wiring: 2A0169, 2A0211, 4A0139 and 4A0165

1. Position the protective tube so that the fan connector sits in the center of the protective tube.



2. Place the fan connector covered by the tube as shown in the drawings below.

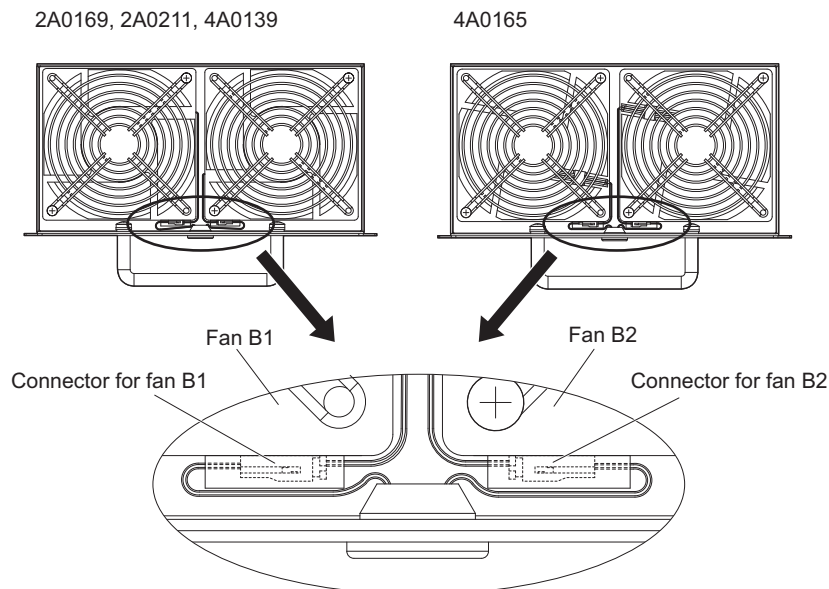
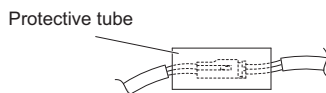


Figure 7.22 Cooling Fan Wiring: 2A0169, 2A0211, 4A0139 and 4A0165

3. Make sure that the protective tube does not stick out beyond the fan guard.

### ■ Cooling Fan Wiring: 2A0250, 2A0312 and 4A0208

1. Position the protective tube so that the fan connector sits in the center of the protective tube.



2. Place the connector for fan B2 before the B1 connector and guide the lead wire for fan B2 so that it is held in place by the cable hook.

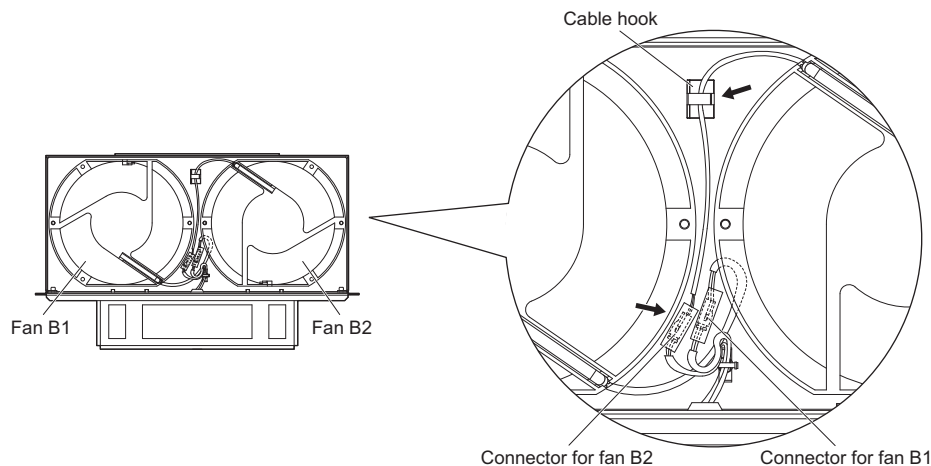


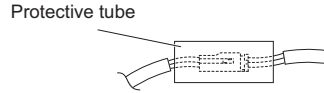
Figure 7.23 Cooling Fan Wiring: 2A0250, 2A0312 and 4A0208

3. Make sure that the protective tube does not stick out beyond the fan guard.

## 7.4 Cooling Fan and Circulation Fan

### ■ Cooling Fan Wiring: 2A0360, 2A0415, 4A0250 to 4A0362

1. Position the protective tube so that the fan connector sits in the center of the protective tube.



2. The fan connector for fan B2 should be placed in front of the fan B1 connector between fans B1 and B2.
3. The connector for fan B3 should be pressed in between fan B2 and B3.

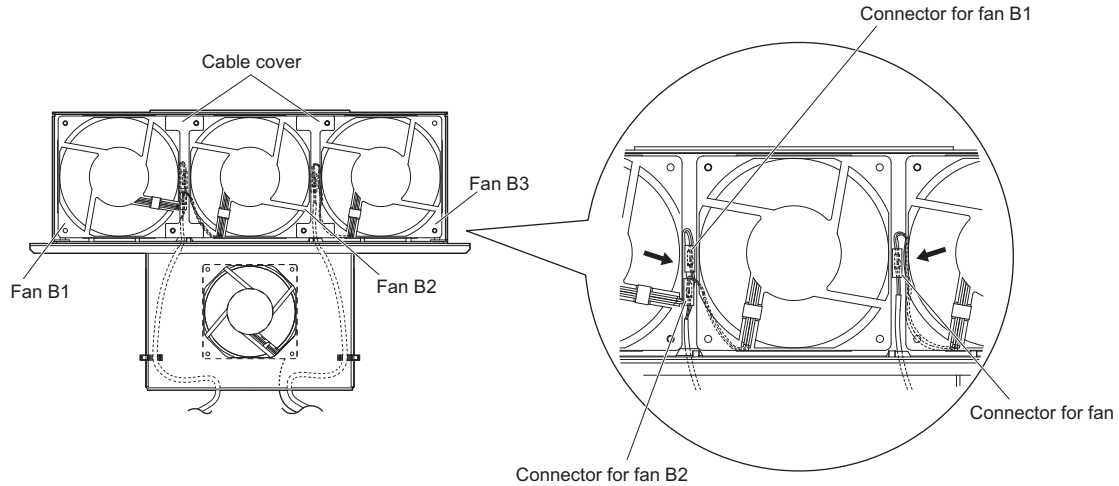


Figure 7.24 Cooling Fan Wiring: 2A0360, 2A0415, 4A0250 to 4A0362

4. Double check the relay connector to ensure that it is properly connected.
5. Reattach the cable cover to its original position and tighten the screws so that the fan guard holds the cable cover in place.

**Note:** Make sure the fan cable does not get pinched between parts when reassembling the fan unit.

### ■ Installing the Cooling Fan Unit

1. Reverse the procedure described above to reinstall the cooling fan unit.

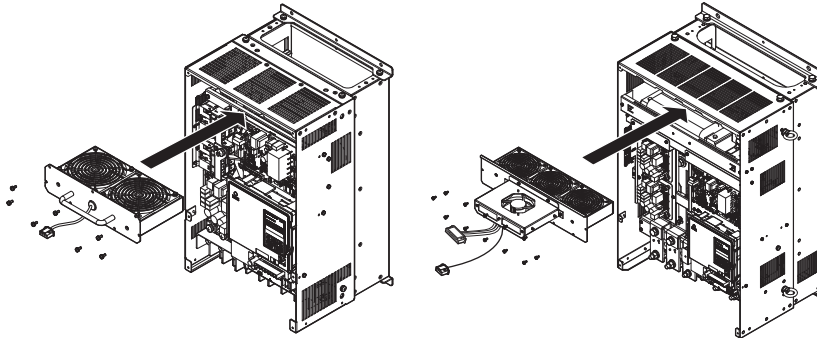


Figure 7.25 Installing the Cooling Fan Unit: 2A0165 to 2A0415, 4A0139 to 4A0362

2. Reattach the covers and digital operator.
3. Turn the power supply back on and reset the cooling fan operation time for the Maintenance Monitor by setting o4-03 to 0.

## ◆ Cooling Fan Replacement: 4A0414

**WARNING!** *Electrical Shock Hazard. Do not connect or disconnect wiring while the power is on. Failure to comply can result in serious personal injury. Before servicing the drive, disconnect all power to the equipment. The internal capacitor remains charged even after the power supply is turned off. After shutting off the power, wait for at least the amount of time specified on the drive before touching any components.*

**CAUTION!** *Burn Hazard. Do not touch a hot drive heatsink and a fan unit. Failure to comply could result in minor or moderate injury. Shut off the power to the drive when replacing the cooling fan. To prevent burns, wait at least 15 minutes and ensure the heatsink and the fan unit have cooled down.*

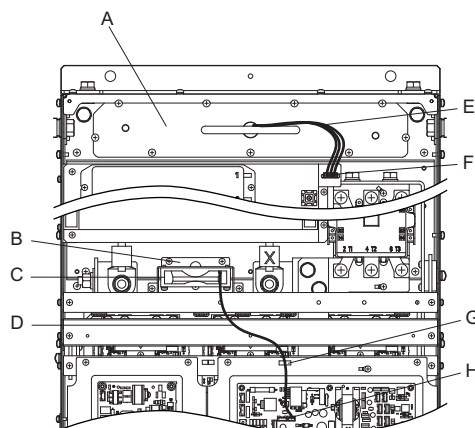
**NOTICE:** *Prevent Equipment Damage. Follow cooling fan and circulation fan replacement instructions. Improper fan replacement could result in damage to equipment. When installing the replacement fan into the drive, make sure the fan is facing upwards. To ensure maximum useful product life, replace all fans when performing maintenance.*

### ■ Removing and Disassembling the Cooling Fan Unit

1. Remove the terminal cover and front cover 1 and 2.

**CAUTION!** *Crush Hazard. Do not completely remove the cover screws, just loosen them. If the cover screws are removed completely, the terminal cover may fall off causing an injury. Take special care when removing/reattaching the terminal covers for larger drives*

2. Remove the fan connector (CN6).



A – Fan Unit	E – Fan Relay Cable
B – Circulation Fan Unit	F – Fan Connector (CN6)
C – Circulation Fan	G – Hook
D – Circulation Fan Relay Cable	H – Fan Connector (CN7)

Figure 7.26 Component Names: 4A0414

3. Remove the circulation fan relay cable from the hook. Remove the fan connector (CN7).
4. Remove the screws holding the fan units in place and slide the fan units out of the drive.

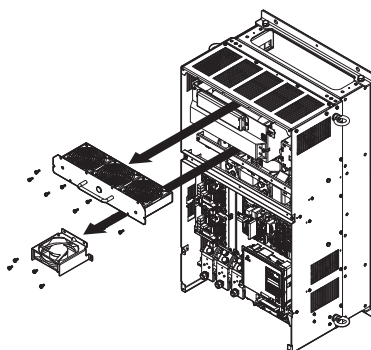


Figure 7.27 Removing the Fan Unit: 4A0414

## 7.4 Cooling Fan and Circulation Fan

5. Remove the fan guard and circulation fan casing. Replace the cooling fans.

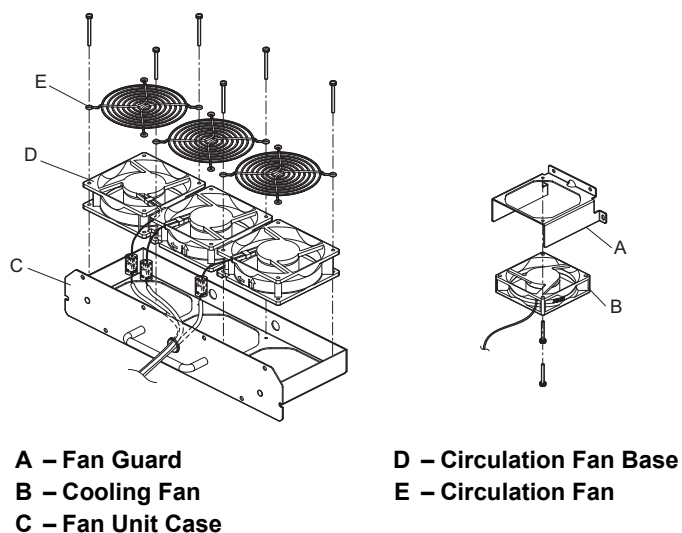
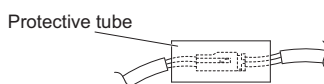


Figure 7.28 Fan Unit Disassembly: 4A0414

### ■ Cooling Fan Wiring

1. Position the protective tube so that the fan connector sits in the center of the protective tube.



2. Place the fan connector covered by the tube as shown in the drawings below.

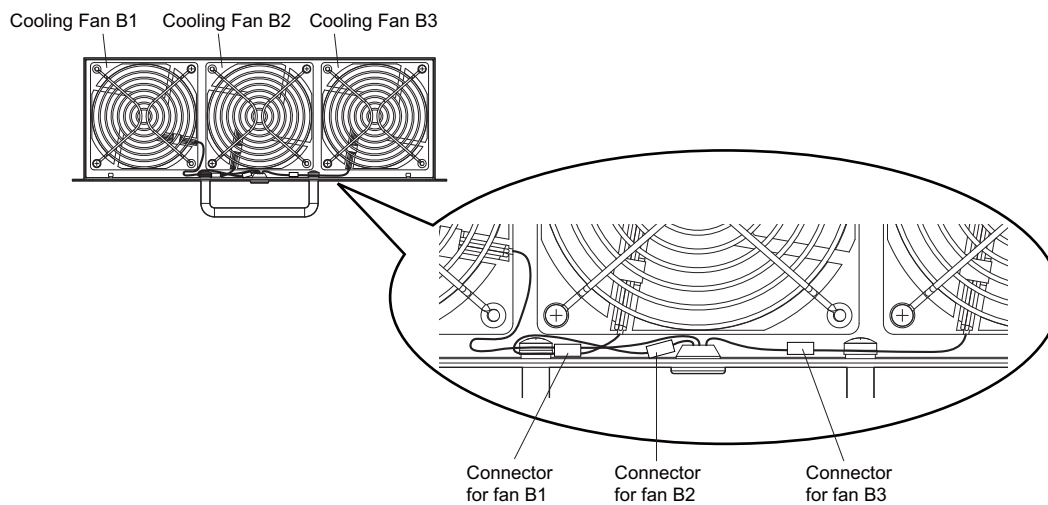


Figure 7.29 Cooling Fan Wiring: 4A0414

3. Double check the relay connector to ensure that it is properly connected.

## ■ Installing the Cooling Fan Unit

1. Reverse the procedure described above to reinstall the cooling fan unit.

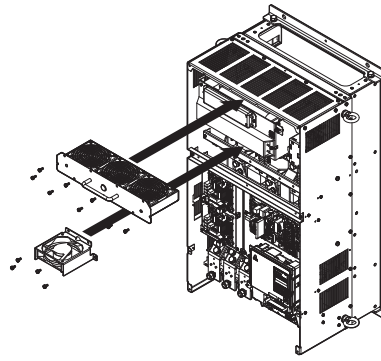


Figure 7.30 Installing the Cooling Fan Unit: 4A0414

2. Reattach the covers and digital operator.
3. Turn the power supply back on and reset the cooling fan operation time for the Maintenance Monitor by setting o4-03 to 0.

## ◆ Cooling Fan Replacement: 4A0515 and 4A0675

**WARNING!** *Electrical Shock Hazard. Do not connect or disconnect wiring while the power is on. Failure to comply can result in serious personal injury. Before servicing the drive, disconnect all power to the equipment. The internal capacitor remains charged even after the power supply is turned off. After shutting off the power, wait for at least the amount of time specified on the drive before touching any components.*

**CAUTION!** *Burn Hazard. Do not touch a hot drive heatsink and a fan unit. Failure to comply could result in minor or moderate injury. Shut off the power to the drive when replacing the cooling fan. To prevent burns, wait at least 15 minutes and ensure the heatsink and the fan unit have cooled down.*

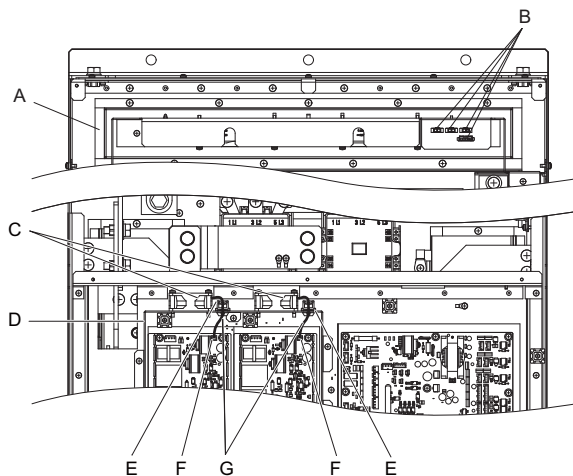
**NOTICE:** *Prevent Equipment Damage. Follow cooling fan and circulation fan replacement instructions. Improper fan replacement could result in damage to equipment. When installing the replacement fan into the drive, make sure the fan is facing upwards. To ensure maximum useful product life, replace all fans when performing maintenance.*

## ■ Removing and Disassembling the Cooling Fan Unit

1. Remove the terminal cover and front cover 1 and 2.

**CAUTION!** *Crush Hazard. Do not completely remove the cover screws, just loosen them. If the cover screws are removed completely, the terminal cover may fall off causing an injury. Take special care when removing/reattaching the terminal covers for larger drives.*

2. Remove the connectors for the cooling fan relay and the circuit board cooling fan.



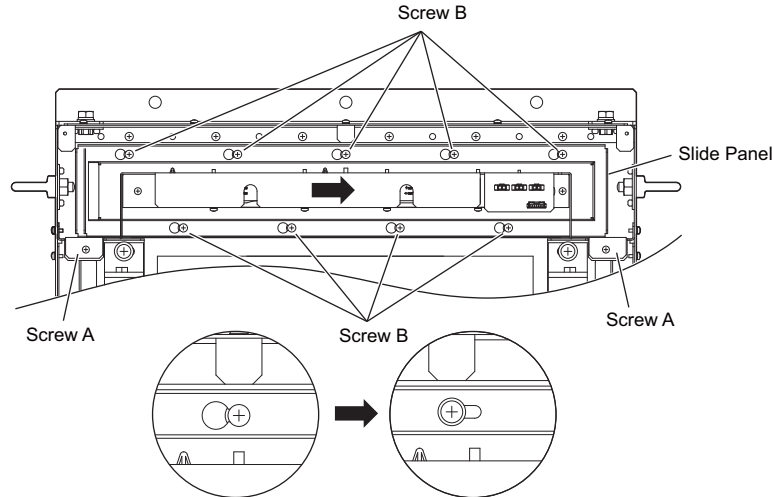
- |                                    |   |
|------------------------------------|---|
| A – Fan Unit                       | E – Hook                                |
| B – Fan Relay Connector            | F – Circuit Board Cooling Fan Connector |
| C – Circuit Board Cooling Fan      | G – Circuit Board Cooling Fan Cable     |
| D – Circuit Board Cooling Fan Case |   |

Figure 7.31 Component Names: 4A0515 and 4A0675

## 7.4 Cooling Fan and Circulation Fan

- Loosen the screw A (2) and the screw B (9), then slide the panel that the screws held into place to the right.

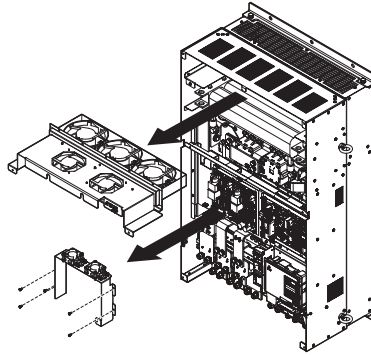
**Note:** The fan unit can be removed simply by loosening these screws.



**Figure 7.32 Removing the Fan Unit: 4A0515 and 4A0675**

- Remove the slide panel and fan unit along with the cooling fan unit for the circuit boards from the drive.

**Note:** The fan unit can be removed simply by loosening these screws.

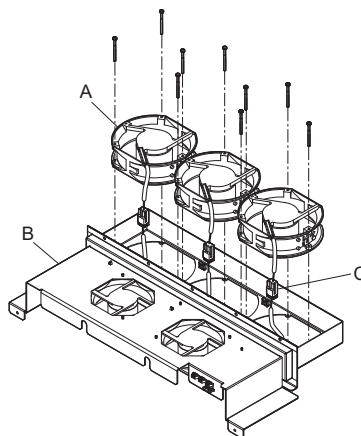


**Figure 7.33 Removing the Fan Units: 4A0515 and 4A0675**

### ■ Replacing the Cooling Fans

- Replace the cooling fans.

**Note:** Make sure the fan cable does not get pinched between parts when reassembling the fan unit.



**A – Cooling Fan**  
**B – Fan Unit Case**

**C – Cooling Fan Connector**

**Figure 7.34 Fan Unit Disassembly: 4A0515 and 4A0675**

- Place the cooling fan connectors and guide the lead wires so that they are held in place by the cable hooks.

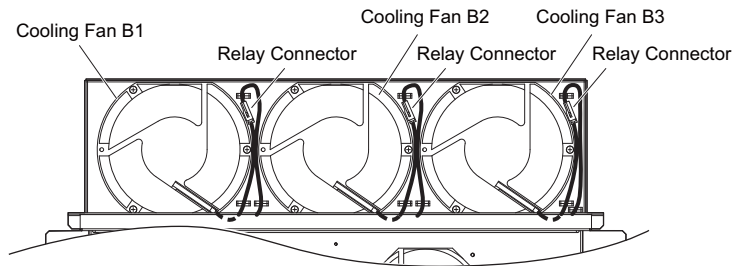
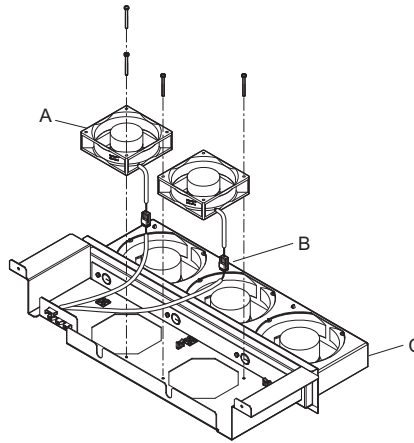


Figure 7.35 Cooling Fan Wiring: 4A0515 and 4A0675

- Turn the fan unit over and replace the circulation fans.



A – Circulation Fan                      C – Fan Unit Case  
 B – Cooling Fan Connector

Figure 7.36 Fan Unit Disassembly: 4A0515 and 4A0675

- Turn over the cooling fan unit. Guide the lead wires so that they are held in place by the cable hooks and place the circulation fan connectors between the fan and fan unit.

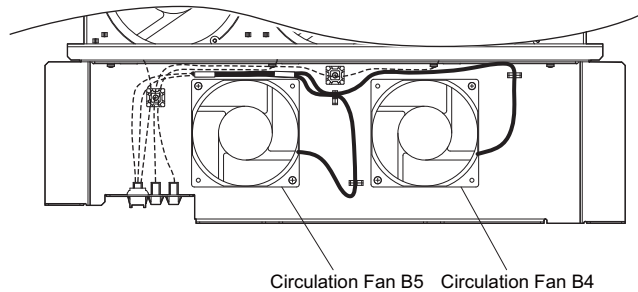
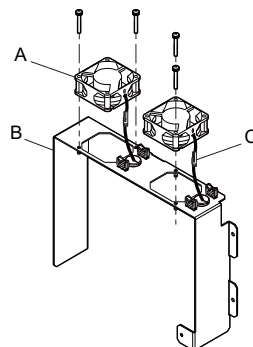


Figure 7.37 Cooling Fan Wiring: 4A0515 and 4A0675

- Replace the cooling fans

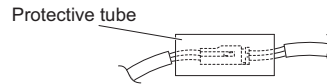


A – Circuit Board Cooling Fan                      C – Relay Connector  
 B – Circuit Board Cooling Fan Case

Figure 7.38 Fan Unit Disassembly: 4A0515 and 4A0675

## 7.4 Cooling Fan and Circulation Fan

6. Position the protective tube so that the fan connector sits in the center of the protective tube. (Only for circuit board cooling fans)



7. Guide lead wires through the hooks provided so that the wires are held in place.

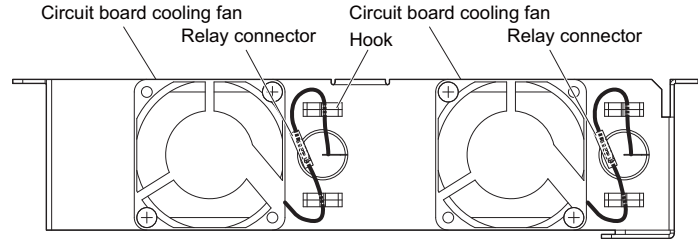


Figure 7.39 Cooling Fan Wiring: 4A0515 and 4A0675

8. Double check the relay connector to ensure that it is properly connected.

### ■ Installing the Cooling Fan Unit

1. Reverse the procedure described above to reinstall the cooling fan unit.

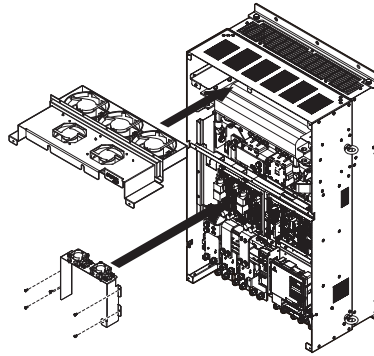


Figure 7.40 Installing the Cooling Fan Units: 4A0515 and 4A0675

2. Reattach the covers and digital operator.
3. Turn the power supply back on and reset the cooling fan operation time for the Maintenance Monitor by setting o4-03 to 0.

### ◆ Cooling Fan Replacement: 4A0930 and 4A1200

**WARNING! Electrical Shock Hazard.** Do not connect or disconnect wiring while the power is on. Failure to comply can result in serious personal injury. Before servicing the drive, disconnect all power to the equipment. The internal capacitor remains charged even after the power supply is turned off. After shutting off the power, wait for at least the amount of time specified on the drive before touching any components.

**CAUTION! Burn Hazard.** Do not touch a hot drive heatsink and a fan unit. Failure to comply could result in minor or moderate injury. Shut off the power to the drive when replacing the cooling fan. To prevent burns, wait at least 15 minutes and ensure the heatsink and the fan unit have cooled down.

**NOTICE: Prevent Equipment Damage.** Follow cooling fan and circulation fan replacement instructions. Improper fan replacement could result in damage to equipment. When installing the replacement fan into the drive, make sure the fan is facing upwards. To ensure maximum useful product life, replace all fans when performing maintenance.

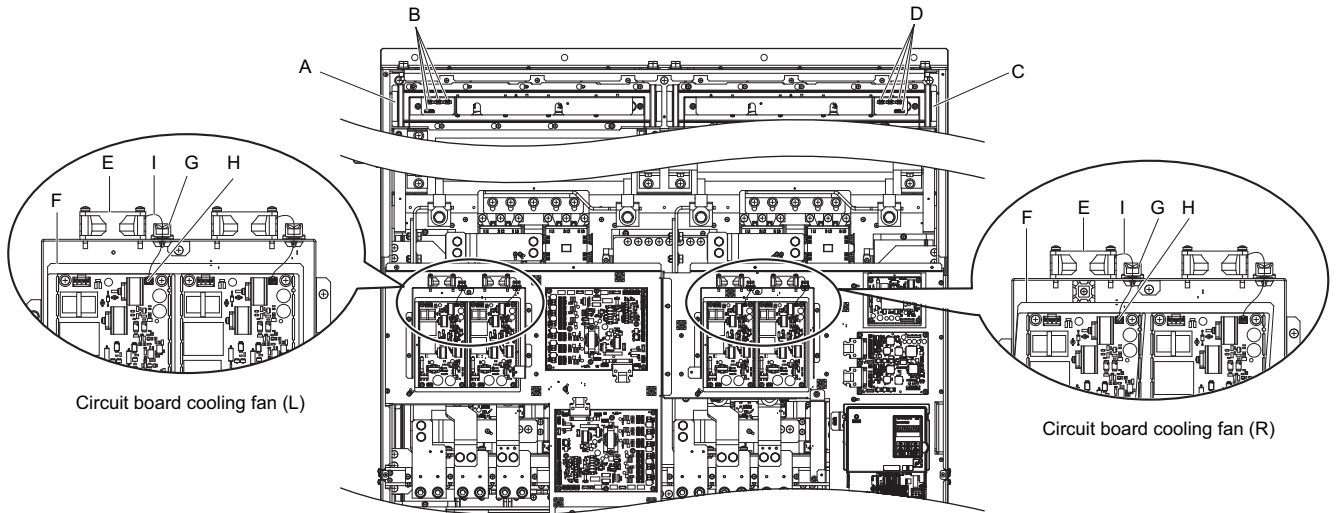
### ■ Removing and Disassembling the Cooling Fan Unit

1. Remove the terminal cover and front covers 1 and 2. Refet to [Removing the Terminal Cover on page 67](#) for details.

**CAUTION! Crush Hazard.** Do not completely remove the cover screws, just loosen them. If the cover screws are removed completely, the terminal cover may fall off causing an injury. Take special care when removing/reattaching the terminal covers for larger drives.



2. Remove the connectors for the cooling fan relay and the circuit board cooling fan.



- A – Fan Unit (L)
- B – Fan Relay Connector (L)
- C – Fan Unit (R)
- D – Fan Relay Connector (R)
- E – Circuit Board Cooling Fan
- F – Circuit Cooling Fan Case
- G – Hook
- H – Circuit Board Cooling Fan Connector
- I – Circuit Board Cooling Fan Cable

Figure 7.41 Component Names: 4A0930 and 4A1200

3. Loosen screw A (4 count) and screw B (18 count), and slide the panel to the right.

**Note:** The fan unit can be removed by loosening these screws; they do not need to be removed.

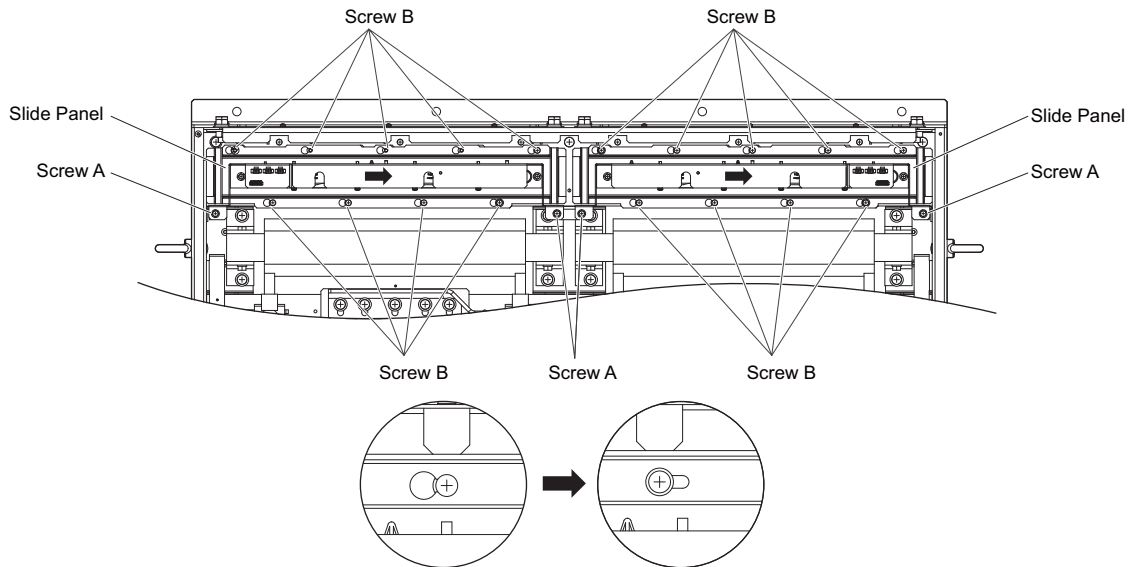


Figure 7.42 Removing the Fan Unit: 4A0930 and 4A1200

- Remove the slide panel, fan unit, cooling fan unit, and circuit board cooling fan unit.

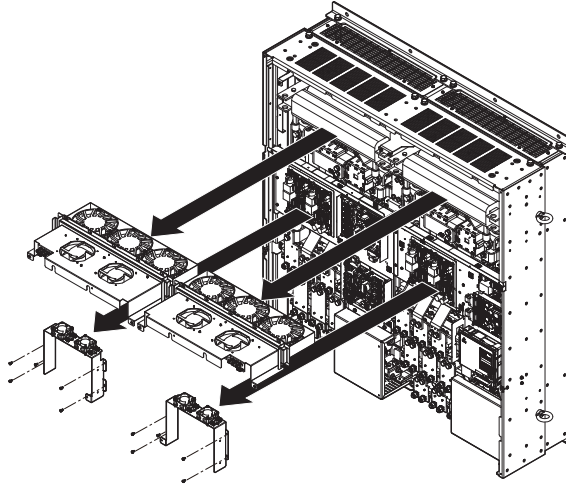
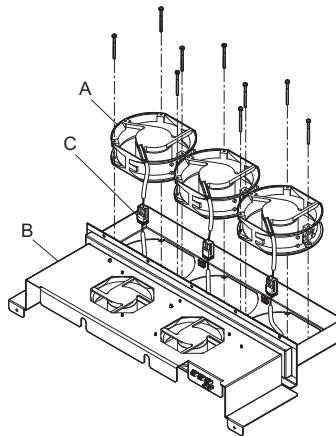


Figure 7.43 Removing the Fan Units: Models 4A0930 and 4A1200

### ■ Replacing the Cooling Fans

- Replace the Cooling Fans.

- Note:
- Figure 7.44 shows the right side fan unit.
  - Do not pinch the fan cable between parts when reassembling the fan unit.



A – Cooling Fan  
B – Fan Unit Case

C – Cooling Fan Connector

Figure 7.44 Replacing the Cooling Fans: Models 4A0930 and 4A1200

- Place the cooling fan connectors and guide the lead wires so that they are held in place by the cable hooks.

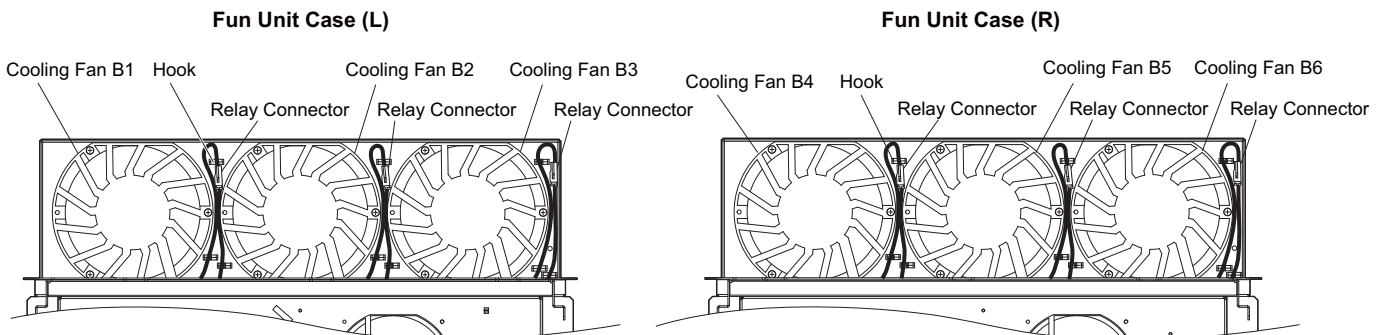


Figure 7.45 Cooling Fan Wiring: Models 4A0930 and 4A1200



## 7.4 Cooling Fan and Circulation Fan

7. Guide lead wires through the provided hooks so the wires are held in place.

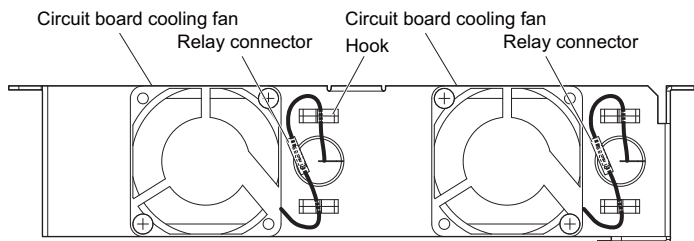


Figure 7.49 Circuit Board Cooling Fan Wiring: 4A0930 and 4A1200

8. Double-check the relay connector to ensure that it is properly connected.

### ■ Installing the Cooling Fan Unit

1. Reverse the procedure described above to reinstall the cooling fan unit.

**Note:** Properly connect the relay connectors to the fan unit connectors.

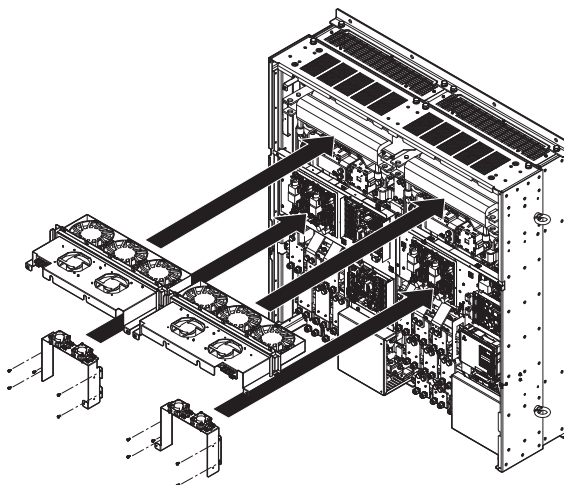


Figure 7.50 Installing the Cooling Fan Units: 4A0930 and 4A1200

2. Reattach the covers and digital operator.
3. Turn the power supply back on and reset the cooling fan operation time for the Maintenance Monitor by setting o4-03 to 0.

## 7.5 Replacing the Air Filter

Models CIMR-E□4A0930 and 4A1200 have built-in air filters.

Contact your Yaskawa representative or the nearest Yaskawa sales office to order new replacement air filters necessary.

Follow the instructions below to remove and replace the air filter.

### ◆ Air Filter Replacement

**WARNING!** *Electrical Shock Hazard. Do not connect or disconnect wiring while the power is on. Failure to comply can result in serious personal injury. Before servicing the drive, disconnect all power to the equipment. The internal capacitor remains charged even after the power supply is turned off. After shutting off the power, wait for at least the amount of time specified on the drive before touching any components.*

**CAUTION!** *Burn Hazard. Do not touch a hot drive heatsink and filter cases. Failure to comply could result in minor or moderate injury. Shut off the power to the drive when replacing the cooling fan. To prevent burns, wait at least 15 minutes and ensure the heatsink and the filter cases have cooled down.*

**NOTICE:** *Prevent Equipment Damage. Follow cooling fan and circulation fan replacement instructions. Improper fan replacement could result in damage to equipment. When installing the replacement fan into the drive, make sure the fan is facing upwards. To ensure maximum useful product life, replace all fans when performing maintenance.*

### ■ Removing the Air Filter

1. Remove the terminal cover. Refer to [Terminal Cover on page 66](#) for more information.
2. Remove the screws holding the blind cover in place on the bottom of the drive. Pull forward on the blind cover to free it from the drive.

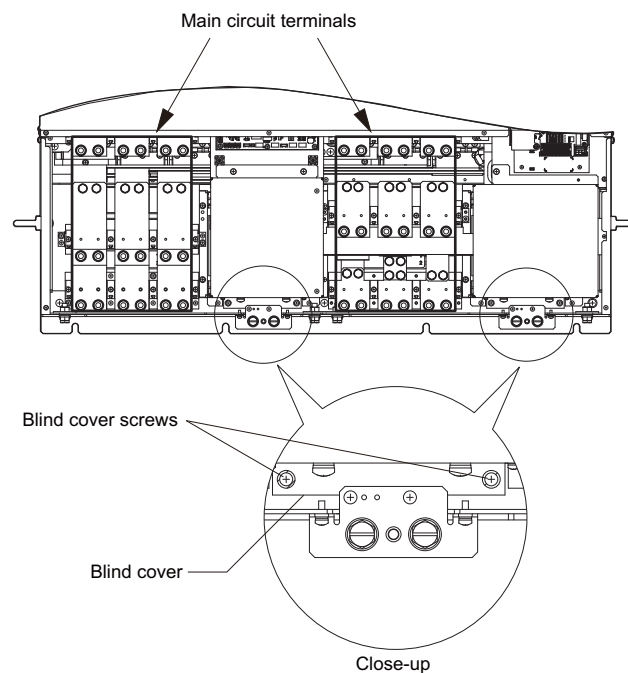
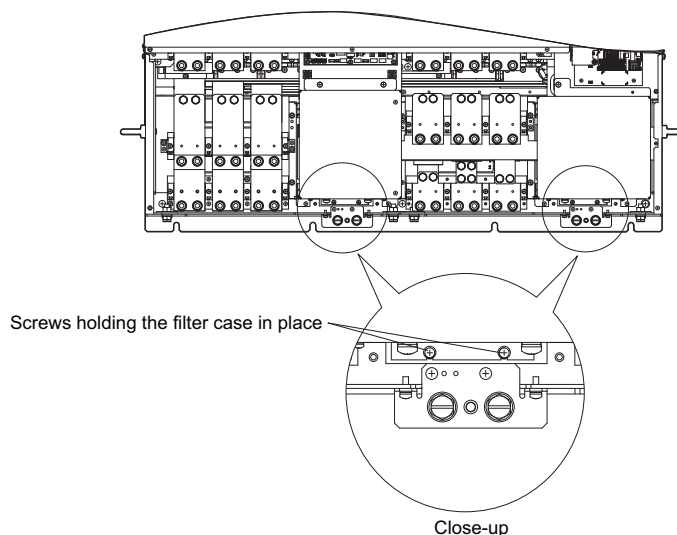


Figure 7.51 Air Filter Replacement: Removing the Blind Cover

## 7.5 Replacing the Air Filter

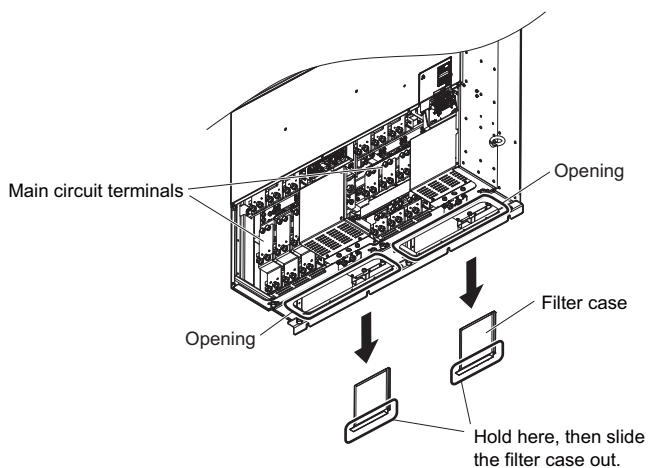
3. Loosen the screws holding the filter case in place.

**Note:** The filter case should not be removed, only loosened.



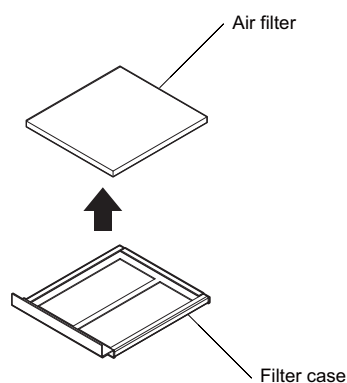
**Figure 7.52 Air Filter Replacement: Loosening the Filter Case Screws**

4. While holding onto the bottom of the filter case, slide it out from the drive.



**Figure 7.53 Air Filter Replacement: Sliding Out the Filter Case**

5. Take the filter out of the filter case.



**Figure 7.54 Air Filter Replacement: Taking Out the Filter**

### ■ Installing the Air Filter

Reverse the procedure described above to reinstall the air filter.

## 7.6 Drive Replacement

### ◆ Serviceable Parts

The drive contains some serviceable parts. The following parts can be replaced over the life span of the drive:

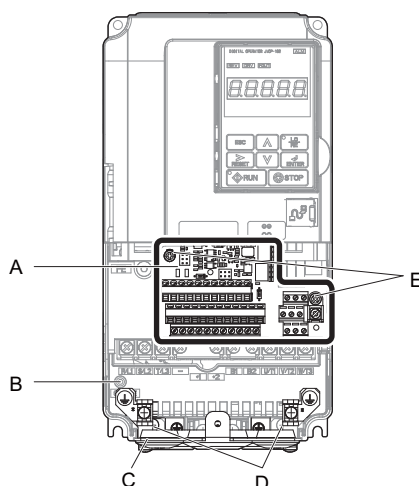
- Terminal board I/O PCBs
- Cooling fan(s)
- Front cover

Replace the drive if the main power circuitry is damaged. Contact your local Yaskawa representative before replacing parts if the drive is still under warranty. Yaskawa reserves the right to replace or repair the drive according to Yaskawa warranty policy.

### ◆ Terminal Board

The drive has a modular I/O terminal block that facilitates quick drive replacement. The terminal board contains on-board memory that stores all drive parameter settings and allows the parameters to be saved and transferred to the replacement drive. To transfer the terminal board, disconnect the terminal board from the damaged drive then reconnect it to the replacement drive. Once transferred, there is no need to manually reprogram the replacement drive.

**Note:** If the damaged drive and the new replacement drive are have different capacities, the data stored in the terminal board cannot be transferred to the new drive and an oPE01 error will appear on the display. The terminal board can still be used, but parameter setting from the old drive cannot be transferred. The replacement drive must be initialized and manually programmed.



A – Removable terminal board  
B – Charge LED  
C – Bottom cover

D – Bottom cover screws  
E – Terminal board locking screws

Figure 7.55 Terminal Board

### ◆ Replacing the Drive

**WARNING! Electrical Shock Hazard.** Do not connect or disconnect wiring while the power is on. Failure to comply can result in serious personal injury. Before servicing the drive, disconnect all power to the equipment. The internal capacitor remains charged even after the power supply is turned off. After shutting off the power, wait for at least the amount of time specified on the drive before touching any components.

**WARNING! Electrical Shock Hazard.** Do not allow unqualified personnel to perform work on the drive. Failure to comply could result in serious injury. Installation, maintenance, inspection and servicing must be performed only by authorized personnel familiar with installation, adjustment and maintenance of AC drives.

**NOTICE: Damage to Equipment.** Observe proper electrostatic discharge procedures (ESD) when handling the drive and circuit boards. Failure to comply may result in ESD damage to the drive circuitry.

The following procedure explains how to replace a drive. This section provides instructions for drive replacement only. To install option boards or other types of options, then refer to the specific manuals for those options.

**NOTICE: When transferring a braking transistor, braking resistor, or other type of option from a damaged drive to a new replacement drive, make sure they are working properly before reconnecting them to the new drive. Replace broken options to prevent immediate break down of the replacement drive.**

1. Remove the terminal cover. Refer to [Terminal Cover on page 66](#) for details.

**NOTICE: The shape of the terminal covers and the numbers of screws differ depending on the drive models. Refer to [Component Names on page 32](#) for details.**

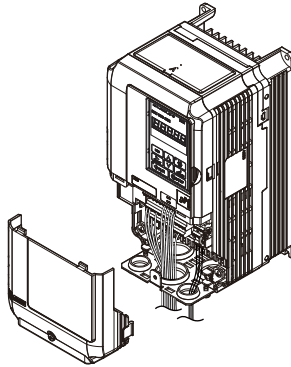


Figure 7.56 Drive Replacement: Removing the Terminal Cover

2. Loosen the screws holding the terminal board in place. Take out the screw securing the bottom cover and remove the bottom cover from the drive.

**Note:** Drives set up for compliance with IP00 do not have a bottom cover.

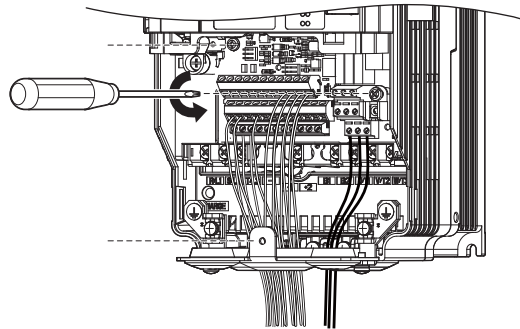


Figure 7.57 Drive Replacement: Removing the Terminal Board



- Slide the terminal board as illustrated by the arrows, and remove it from the drive along with the bottom cover.

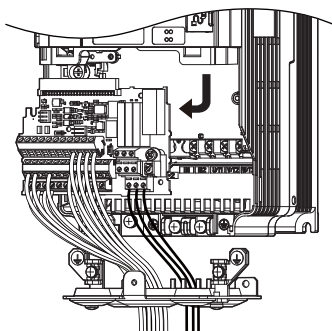


Figure 7.58 Drive Replacement: Remove the Terminal Board

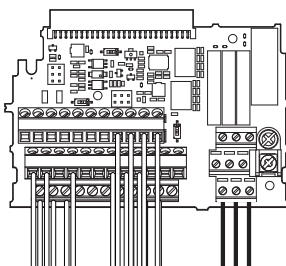


Figure 7.59 Drive Replacement:  
Removable Terminal Board Disconnected from the Drive

- Disconnect all option cards and options. Make sure they are intact before reusing them.
- Replace the drive and wire the main circuit.

## ■ Installing the Drive

- Once the main circuit has been wired, connect the terminal block to the drive as shown in [Figure 7.60](#). Use the installation screw to fasten the terminal block into place.

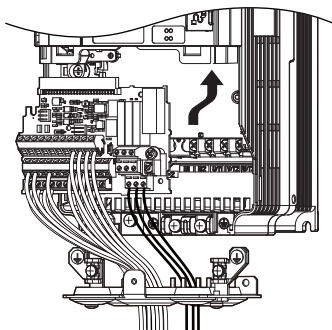


Figure 7.60 Drive Replacement: Installing the Terminal Board

- Reconnect all options to the new drive in the same way they were installed in the old drive. Connect option boards to the same option ports in the new drive that were used in the old drive.
- Put the terminal cover back into its original place.
- When the power to the drive is first switched on, all parameter settings are transferred from the terminal board into the drive memory. Should an oPE04 error occur, load the parameter settings that have been saved on the terminal board onto the new drive by setting parameter A1-03 to 5550. Reset timers used for the Maintenance Monitor function by setting parameters o4-01 through o4-12 back to 0, and parameter o4-13 to 1.



# Peripheral Devices & Options

---

This chapter explains the installation of peripheral devices and options available for the drive.

<b>8.1 SECTION SAFETY</b> .....	<b>332</b>
<b>8.2 DRIVE OPTIONS AND PERIPHERAL DEVICES</b> .....	<b>333</b>
<b>8.3 CONNECTING PERIPHERAL DEVICES</b> .....	<b>335</b>
<b>8.4 OPTION CARD INSTALLATION</b> .....	<b>336</b>
<b>8.5 INSTALLING PERIPHERAL DEVICES</b> .....	<b>340</b>

## 8.1 Section Safety

### DANGER

#### Electrical Shock Hazard

**Do not connect or disconnect wiring while the power is on.**

Failure to comply will result in death or serious injury.

The internal capacitor remains charged even after the power supply is turned off. After shutting off the power, wait for at least the amount of time specified on the drive before touching any components.

### WARNING

#### Electrical Shock Hazard

**Do not operate equipment with covers removed.**

Failure to comply could result in death or serious injury.

The diagrams in this section may show drives without covers or safety shields to show details. Be sure to reinstall covers or shields before operating the drives and run the drives according to the instructions described in this manual.

**Do not remove covers or touch circuit boards while the power is on.**

Failure to comply could result in death or serious injury.

**Do not allow unqualified personnel to perform work on the drive.**

Failure to comply could result in death or serious injury.

Installation, maintenance, inspection and servicing must be performed only by authorized personnel familiar with installation, adjustment and maintenance of AC drives.

**Do not perform work on the drive while wearing loose clothing, jewelry or without eye protection.**

Failure to comply could result in death or serious injury.

Remove all metal objects such as watches and rings, secure loose clothing and wear eye protection before beginning work on the drive.

**Always ground the motor-side grounding terminal.**

Improper equipment grounding could result in death or serious injury by contacting the motor case.

#### Fire Hazard

**Tighten all terminal screws to the specified tightening torque.**

Loose electrical connections could result in death or serious injury by fire due to overheating of electrical connections.

### NOTICE

**Observe proper electrostatic discharge procedures (ESD) when handling the drive and circuit boards.**

Failure to comply may result in ESD damage to the drive circuitry.

**Never connect or disconnect the motor from the drive while the drive is outputting voltage.**













Improper equipment sequencing could result in damage to the drive.

## 8.2 Drive Options and Peripheral Devices




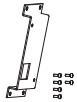
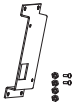

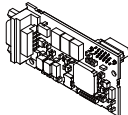
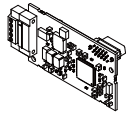
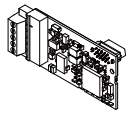
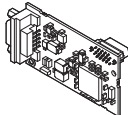
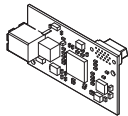
The following table of peripheral devices lists the names of the various accessories and options available for Yaskawa drives. Contact Yaskawa or your Yaskawa agent to order these peripheral devices.

- **Peripheral Device Selection:** Refer to the Yaskawa catalog for selection and part numbers.
- **Peripheral Device Installation:** Refer to the corresponding option manual for installation instructions.

**Table 8.1 Available Peripheral Devices**

Option	Model Number		Description
<b>Power Options</b>			
	DC Reactor	UZDA Series	Improves the power factor by suppressing harmonic distortion from the power supply.
	AC Reactor	UZBA Series	Protects the drive when operating from a large power supply and improves the power factor by suppressing harmonic distortion. Highly recommended for power supplies that exceed 600 kVA.
	Braking Resistor Unit	LKEB Series	For use with systems requiring dynamic braking with up to 10% ED.
	Braking Unit	CDBR Series	External braking transistor
	Molded Case Circuit Breaker	NF Series	Circuit breaker for short circuit or over load protection <b>Note:</b> Yaskawa recommends installing an MCCB to the power supply side to protect drive wiring and prevent other damage in the event of component failure. Install an MCCB if permitted by the power system.
	Earth Leakage Circuit Breaker (ELCB)	NV, EG, or SG Series	Provides protection against potentially harmful leakage current. <b>Note:</b> Yaskawa recommends installing a LECB to the power supply side to protect drive wiring and prevent other damage in the event of component failure. An MCCB can also be used if permitted by the power system.
	Magnetic Contactor (Input)	SC Series	Ensures that power to drive is completely shut off when necessary, preventing potential damage to the braking resistor and other internal circuitry. Install an MCCB when using a braking resistor to prevent the braking resistor from overheating. To protect internal components from sudden high levels of input current, the MC should be wired so that it opens when a fault output terminal is triggered.
	Surge Protector	200 V class: DCR2-□A 400 V class: RFN3AL-504KD	Suppresses surge voltage caused by magnetic contactor switching.
	Zero Phase Reactor	F6045GB, F11080GB	Reduces electromagnetic noise.
	Fuse	200 V class: CR2LS or CR2L Series, FWX Series 400 V class: CR6L Series, FWH Series	Protects the drive in case of short circuit.
	Input Noise Filter	LNFB, LNFD, FN Series	Reduces electromagnetic noise flowing back from the drive into power supply.
	Output Noise Filter	LF-310 Series	Reduces electromagnetic noise generated by the drive output.
—	Isolator	DGP□□□	Isolates the drive control I/Os for improved noise resistance.
—	Momentary Power Loss Recovery Unit	200 V class: P0010 400 V class: P0020	Ensures drive operation during momentary power loss up to 2 s
<b>Reference Setting / Monitor Options</b>			
—	Frequency Meter / Ammeter	DCF-6A	External meter for displaying the output frequency or current using an analog signal from the drive
—	Frequency Meter Potentiometer (20 kΩ)	RH000850	External potentiometer for adjusting the frequency meter scaling
—	Output Voltage Meter	SDF-12NH	External meter for displaying the output voltage using an analog signal from the drive
—	Frequency Setting Potentiometer (2 kΩ)	RH000739	External potentiometer for setting the frequency reference by an analog input
—	Control Dial for Frequency Setting Potentiometer	CM-3S	Control dial for frequency setting potentiometer
—	Meter Plate	NPJT41561-1	Plate with scale for frequency setting potentiometer

## 8.2 Drive Options and Peripheral Devices

Option	Model Number	Description
<b>Interface Options</b>		
	LCD Operator JVOP-180	Digital operator with 8 languages, clear text LCD display, and copy function; max. cable length for remote usage: 3 m
	Remote Operator Cable WV001/WV003	Extension cable (1 m or 3 m) to connect the digital operator for remote operation RJ-45, 8 pin straight through, UTP CAT5e cable
	USB Copy Unit JVOP-181	Allows the user to copy and verify parameter settings between drives. Can also be used as an adapter to connect the drive to the USB port on a PC.
<b>Attachment</b>		
—	Attachment for External Heatsink EZZ020800A/B/C/D	Installation kit for mounting the drive with the heatsink outside of the panel (Side-by-Side mounting possible)
—	Condenser Cover ECAT31726-1, ECAT31698-1	This cover protects the DC bus capacitors when mounting the heatsink outside the enclosure. It is required for UL approval. For more information, contact our sales department directly or your nearest Yaskawa representative.
—	NEMA 1 Kit EZZ020787	Parts to make the drive conform to NEMA Type 1 enclosure requirements
	Installation Support Set A EZZ020642A	For installing the digital operator keypad on the outside of an enclosure panel that houses the drive. Uses screws to secure the operator.
	Installation Support Set B EZZ020642B	For installing the digital operator keypad on the outside of an enclosure panel that houses the drive. Uses nuts to secure the operator for installations where screws are not practical.
<b>Others</b>		
	24 V Power Supply 200 V class: PS-A10LB 400 V class: PS-A10HB	Provides power to the control circuit and option boards in the event of power loss. Allows the user to still monitor drive settings and fault information even if the main circuit has no power.
—	DriveWizard Plus	— PC tool for drive setup and parameter management
—	DriveWorksEZ	— PC tool for enhanced programming of the drive
<b>Communication Options</b>		
	PROFIBUS-DP <1> SI-P3	Connects to a PROFIBUS-DP network.
	CC-Link <1> SI-C3	Connects to a CC-Link network
	DeviceNet <1> SI-N3	Connects to a DeviceNet network
	CANopen <1> SI-S3	Connects to a CANopen network
	MECHATROLINK-II <1> SI-T3	Connects to a MECHATROLINK-II network

<1> Under development

# 8.3 Connecting Peripheral Devices

Figure 8.1 illustrates how to configure the drive and motor to operate with various peripheral devices.

- For more detailed instructions on how to install each device shown below, refer to the specific manual for that device.

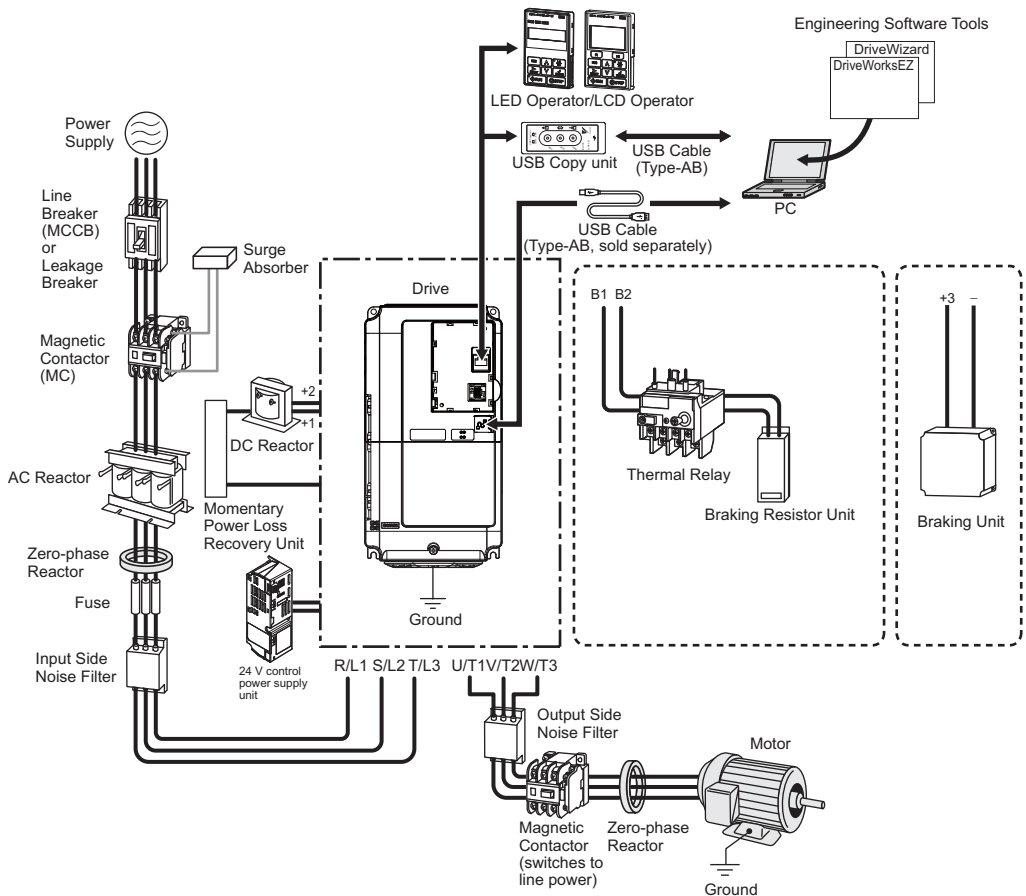


Figure 8.1 Connecting Peripheral Devices

**Note:** Note that if the drive is set to trigger a fault output whenever the fault restart function is activated (L5-02 = 1), then a sequence to interrupt power when a fault occurs will result in shutting off the power to the drive as the drive attempts to restart itself. The default setting for L5-02 is 0 (fault output active during restart attempt).

## 8.4 Option Card Installation

This section provides instructions on installing the option cards listed in [Table 8.1](#).

### ◆ Prior to Installing the Option

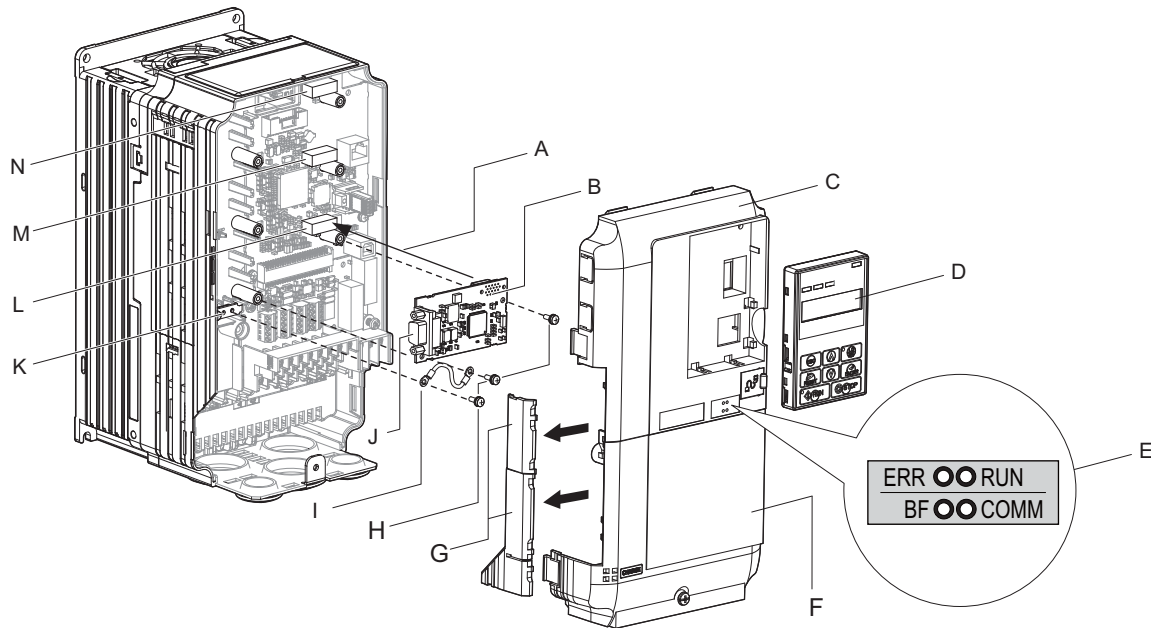
Prior to installing the option, wire the drive, make the necessary connections to the drive terminals, and verify that the drive functions normally.

[Table 8.2](#) lists the number of option cards that can be connected to the drive and the drive connector for connecting those option cards.

**Table 8.2 Option Card Installation**

Option Card	Connector	Number of Cards Possible
SI-C3, SI-N3, SI-P3, SI-S3, SI-T3	CN5-A	1

[Figure 8.2](#) shows an exploded view of the drive with the option and related components for reference.



- |  |  |
|--|--|
| <b>A</b> – Insertion point for CN5         | <b>H</b> – Included screws               |
| <b>B</b> – Option card                     | <b>I</b> – Ground wire                   |
| <b>C</b> – Front cover                     | <b>J</b> – CN5 communication connector   |
| <b>D</b> – Digital operator                | <b>K</b> – Drive grounding terminal (FE) |
| <b>E</b> – LED label <1>                   | <b>L</b> – Connector CN5-A               |
| <b>F</b> – Terminal cover                  | <b>M</b> – Connector CN5-B               |
| <b>G</b> – Removable tabs for wire routing | <b>N</b> – Connector CN5-C               |

<1> LED label varies depending on the option models.

**Figure 8.2 Drive Components with Option**



## ◆ Installing the Option

Refer to the instructions below to install the option.

**DANGER!** *Electrical Shock Hazard. Disconnect all power to the drive and wait at least the amount of time specified on the drive front cover safety label. After all indicators are off, measure the DC bus voltage to confirm safe level, and check for unsafe voltages before servicing to prevent electric shock. The internal capacitor remains charged even after the power supply is turned off.*

**WARNING!** *Electrical Shock Hazard. Do not allow unqualified personnel to perform work on the drive. Failure to comply could result in death or serious injury. Maintenance, inspection, and replacement of parts must be performed only by authorized personnel familiar with installation, adjustment and maintenance of AC drives and Option Cards.*

**NOTICE:** *Damage to Equipment. Observe proper electrostatic discharge procedures (ESD) when handling the option card, drive, and circuit boards. Failure to comply may result in ESD damage to circuitry.*

**NOTICE:** *Damage to Equipment. Tighten all terminal screws to the specified tightening torque. Failure to comply may cause the application to operate incorrectly or damage the drive.*

1. Shut off power to the drive, wait the appropriate amount of time for voltage to dissipate, then remove the digital operator (D) and front covers (C, F). Refer to the [Terminal Cover on page 66](#) and [Digital Operator and Front Cover on page 68](#) for details.

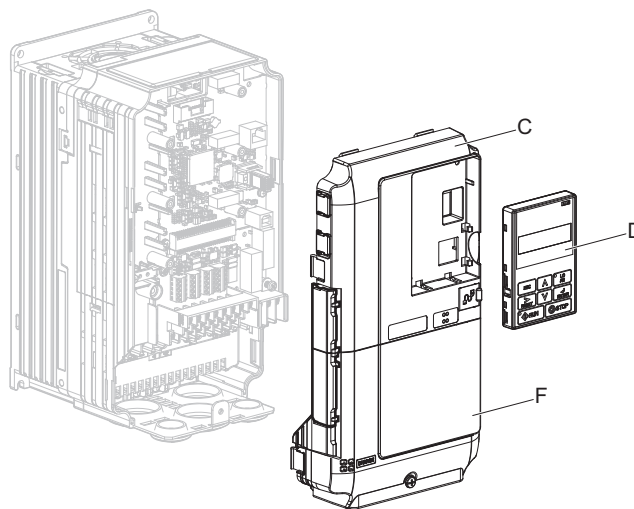


Figure 8.3 Remove the Front Covers and Digital Operator

2. With the front covers and digital operator removed, apply the LED label (E) in the appropriate position on the drive top front cover (C).

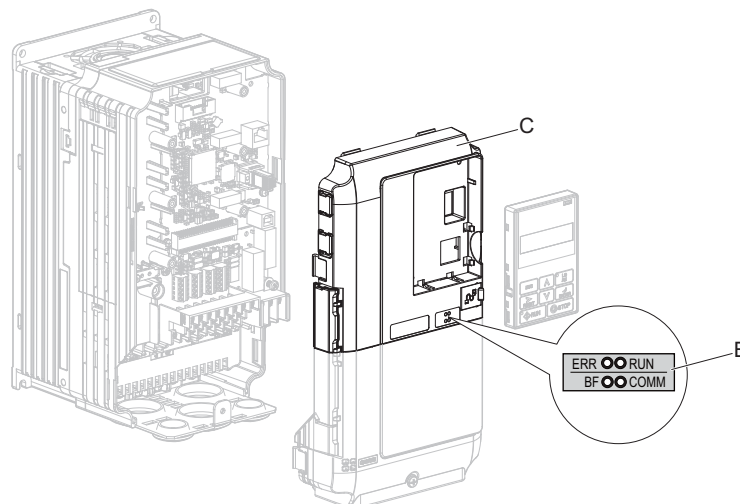


Figure 8.4 Apply the LED Label

## 8.4 Option Card Installation

3. Insert the option card (B) into the CN5-A connector (L) located on the drive and fasten it using one of the included screws (H).

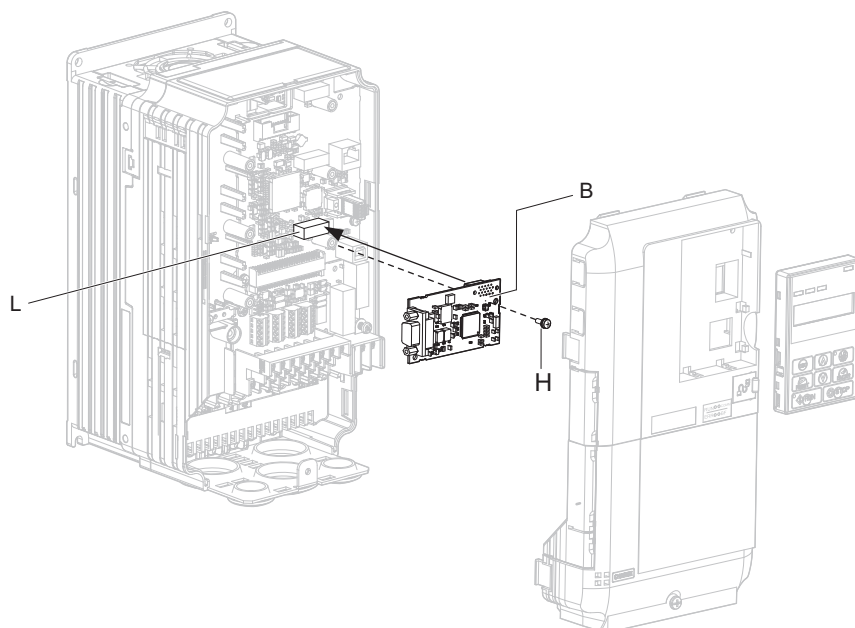


Figure 8.5 Insert the Option Card

4. Connect the ground wire (I) to the ground terminal (K) using one of the remaining provided screws (H). Connect the other end of the ground wire (I) to the remaining ground terminal and installation hole on the option using the last remaining provided screw (H).

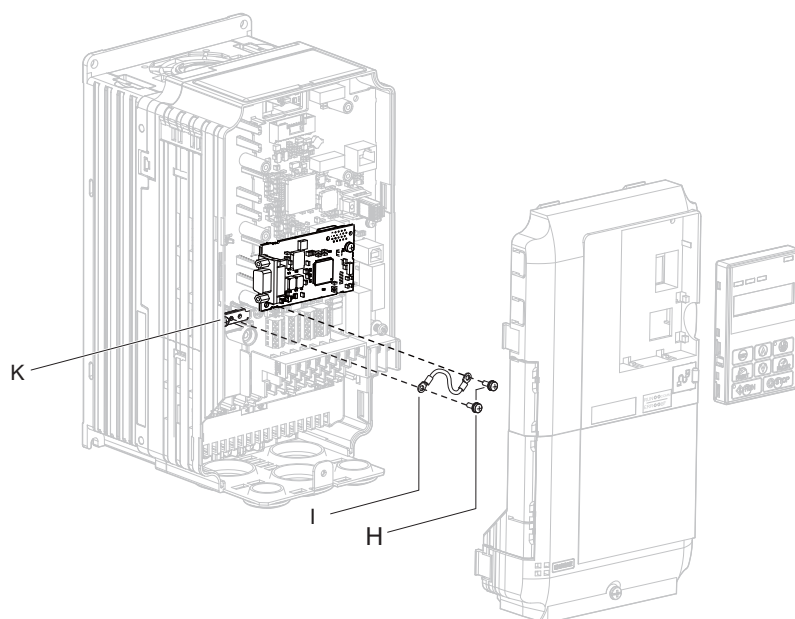
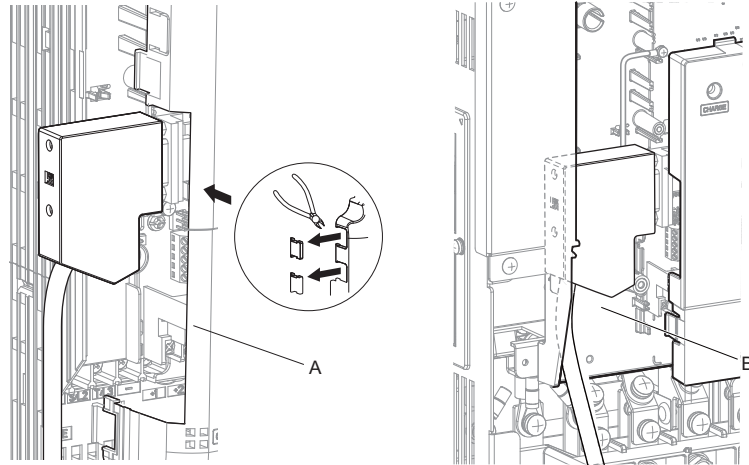


Figure 8.6 Connect the Ground Wire

5. Route the option wiring.  
 Drive models CIMR-E□2A0004 through 2A0040, and 4A0002 through 4A0023 require routing the wiring through the side of the front cover to the outside. Use diagonal cutters to cut out the perforated openings in the left side of the drive front cover as shown in **Figure 8.7-A** and leave no sharp edges to damage wiring. Route the wiring inside the enclosure as shown in **Figure 8.7-B** for drive models CIMR-E□2A0056 through 2A0415 and 4A0031 through 4A1200.



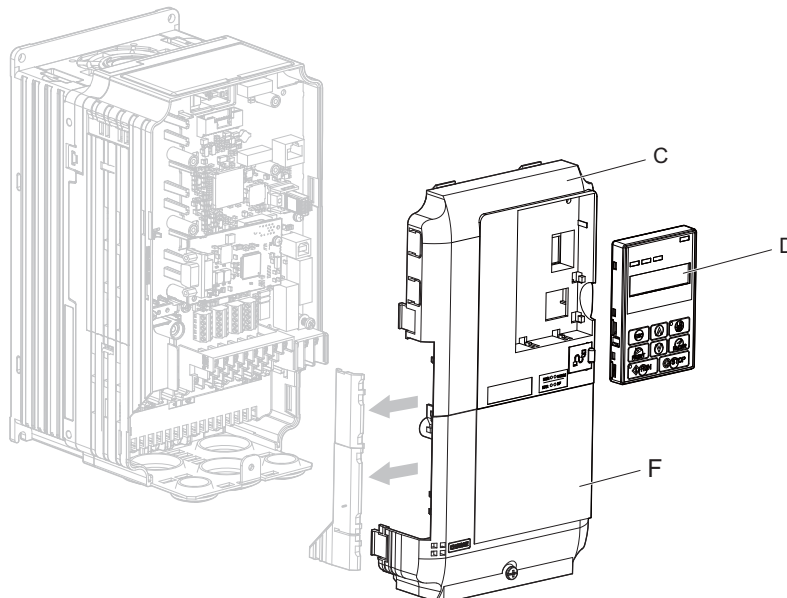
**A** – Route wires through the openings provided on the left side of the front cover. <1>  
 (CIMR-E□2A0004 through 2A0040, and 4A0002 through 4A0023)

**B** – Use the open space provided inside the drive to route option wiring.  
 (CIMR-E□2A0056 through 2A0415 and 4A0031 through 4A1200)

<1> The drive will not meet NEMA Type 1 requirements if wiring is exposed outside the enclosure.

**Figure 8.7 Wire Routing Examples**

6. After connecting the cable to the communication connector CN5, recheck the option wire routing.  
 7. Replace and secure the front covers of the drive (C, F) and replace the digital operator (D).



**Figure 8.8 Replace the Front Covers and Digital Operator**

**Note:** Take proper precautions when wiring the option so that the front covers will easily fit back onto the drive. Make sure no cables are pinched between the front covers and the drive when replacing the covers.

## 8.5 Installing Peripheral Devices

This section describes the proper steps and precautions to take when installing or connecting various peripheral devices to the drive.

**NOTICE:** Use a class 2 power supply (UL standard) when connecting to the control terminals. Improper application of peripheral devices could result in drive performance degradation due to improper power supply.

### ◆ Dynamic Braking Options

Dynamic braking (DB) helps bring the motor to a smooth and rapid stop when working with high inertia loads. As the drive lowers the frequency of a motor moving a high inertia load, regeneration occurs. This can cause an overvoltage situation when the regenerative energy flows back into the DC bus capacitors. A braking resistor prevents these overvoltage faults.

**NOTICE:** Do not allow unqualified personnel to use the product. Failure to comply could result in damage to the drive or braking circuit. Carefully review the braking resistor instruction manual when connecting a braking resistor option to the drive.

**Note:** The braking circuit must be sized properly in order to dissipate the power required to decelerate the load in the desired time. Ensure that the braking circuit can dissipate the energy for the set deceleration time prior to running the drive.

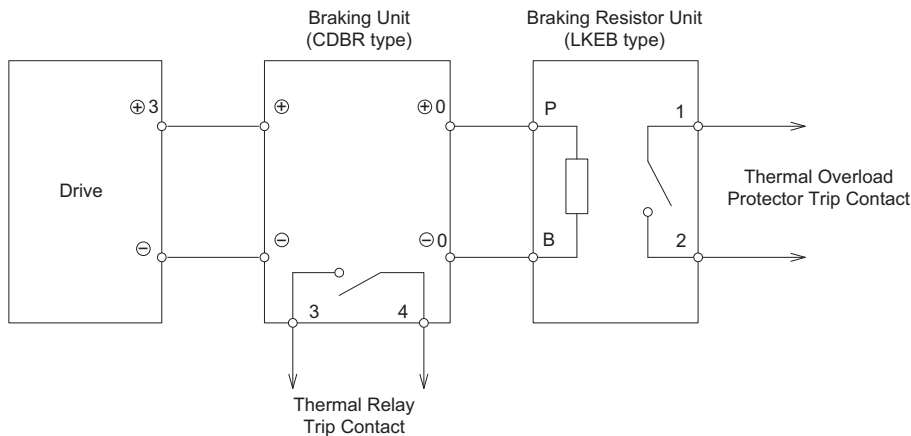
**NOTICE:** Connect braking resistors to the drive as shown in the I/O wiring examples. Improperly wiring braking circuits could result in damage to the drive or equipment.

### ■ Installing a Braking Unit: CDBR Type

To install a CDBR type braking unit, connect the drive's +3 terminal (CIMR-E□2A0169 to 2A0415 and CIMR-E□4A0088 to 4A1200) to the positive terminal on the braking unit. Next wire the negative terminals on the drive and braking unit together.

Connect the braking resistor to the CDBR's terminals +0 and -0.

Wire the thermal overload relay contact of the CDBR and the braking resistor in series, and connect this signal to a drive digital input. Use this input to trigger a fault in the drive in case a CDBR or braking resistor overload occurs.



**Figure 8.9** Connecting a Braking Unit (CDBR type) and Braking Resistor Unit (LKEB type) (CIMR-E□2A0169 to 2A0415, E□4A0088 to 4A1200)

### ■ Using Braking Units in Parallel

When multiple braking units are used, they must be installed with a master-slave configuration with a single braking unit acting as the master. *Figure 8.10* illustrates how to wire braking units in parallel.

Wire the thermal overload contacts relays of all CDBRs and all braking resistors in series, then connect this signal to a drive digital input. This input can be used to trigger a fault in the drive in case of overload in any of the CDBRs or braking resistors.

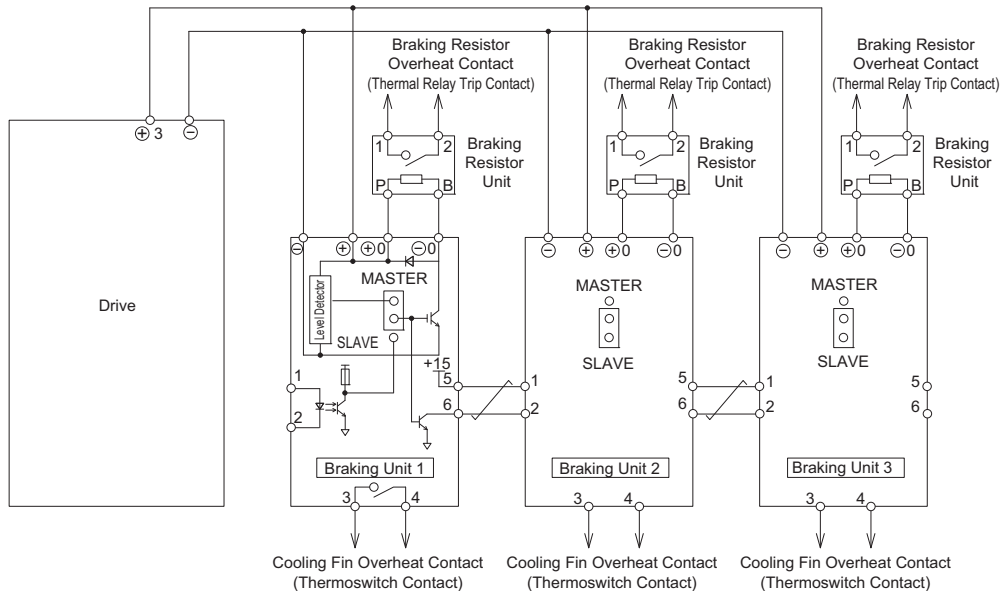


Figure 8.10 Connecting Braking Units in Parallel

### ◆ Installing a Molded Case Circuit Breaker (MCCB) and Earth Leakage Circuit Breaker (ELCB)

Install a MCCB or ELCB for line protection between the power supply and the main circuit power supply input terminals R/L1, S/L2, and T/L3. This protects the main circuit and devices wired to the main circuit while also providing overload protection.

Consider the following when selecting and installing an MCCB or ELCB:

- The capacity of the MCCB or ELCB should be 1.5 to 2 times the rated output current of the drive. Use an MCCB or ELCB to keep the drive from faulting out instead of using overheat protection (150% for one minute at the rated output current).
- If several drives are connected to one MCCB or ELCB that is shared with other equipment, use a sequence that shuts the power OFF when errors are output by using magnetic contactor (MC) as shown in the following figure.

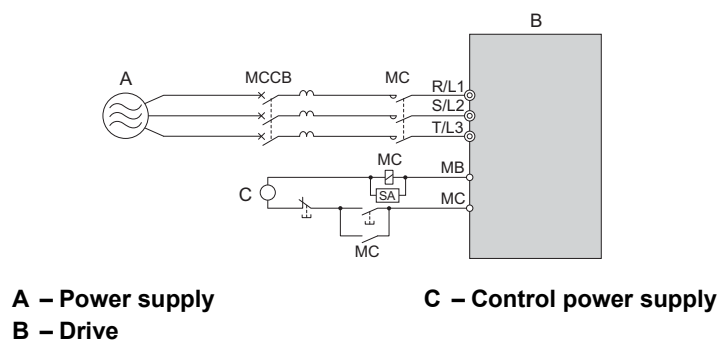


Figure 8.11 Power Supply Interrupt Wiring (Example)

**WARNING!** *Electrical Shock Hazard. Disconnect the MCCB (or ELCB) and MC before wiring terminals. Failure to comply may result in serious injury or death.*

### ■ Installing a Leakage Breaker

Drive outputs generate high-frequency leakage current as a result of high-speed switching. Install an Earth Leakage Circuit Breaker (ELCB) on the input side of the drive to switch off potentially harmful leakage current.

Because each drive generates about 100 mA of leakage current across a 1 m cable and another 5 mA for each additional meter, each drive should have a leakage breaker with a sensitivity amperage of at least 30 mA per drive. This will eliminate harmonic leakage current and suppress any potentially harmful frequencies.

Leakage current can cause unprotected components to operate incorrectly. If this is a problem, lower the carrier frequency, replace the components in question with parts protected against harmonic current, or increase the sensitivity amperage of the leakage breaker to at least 200 mA per drive.

Factors in determining leakage current:

- Size of the AC drive
- AC drive carrier frequency
- Motor cable type and length
- EMI/RFI filter

In order to safely protect the drive system, select a breaker that senses all types of current (AC and DC) and high frequency currents.

---

### ◆ Installing a Magnetic Contactor at the Power Supply Side

Install a magnetic contactor to the drive input for the purposes explained below.

#### ■ Disconnecting the Power Supply

The drive should be shut off with a magnetic contactor (MC) when a fault occurs in any external equipment such as braking resistors.

**NOTICE:** Do not connect electromagnetic switches or magnetic contactors to the output motor circuits without proper sequencing. Improper sequencing of output motor circuits could result in damage to the drive.

**NOTICE:** Install a MC on the input side of the drive when the drive should not automatically restart after power loss. To get the full performance life out of the electrolytic capacitors and circuit relays, refrain from switching the drive power supply off and on more than once every 30 minutes. Frequent use can damage the drive. Use the drive to stop and start the motor.

**NOTICE:** Use a magnetic contactor (MC) to ensure that power to the drive can be completely shut off when necessary. The MC should be wired so that it opens when a fault output terminal is triggered.

- Note:**
1. To keep the drive from restarting automatically when power is restored after momentary power loss, install a magnetic contactor to the drive input.
  2. To have the drive continue operating through momentary power loss, set up a delay for the magnetic contactor so that it does not open prematurely.
- 

### ◆ Connecting an AC or DC Reactor

AC and DC reactors suppress surges in current and improve the power factor on the input side of the drive.

Use a DC reactor or AC reactor or both:

- To suppress harmonic current or improve the power factor of the power supply.
- When using a phase advancing capacitor switch.
- With a large capacity power supply transformer (over 600 kVA).

**Note:** Use an AC or DC reactor when also connecting a thyristor converter (such as a DC drive) to the same power supply system, regardless of the conditions of the power supply.

## ■ Connecting an AC Reactor

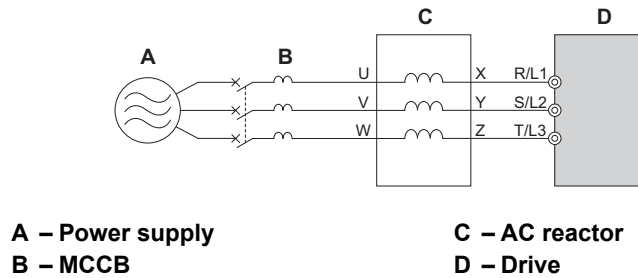


Figure 8.12 Connecting an AC Reactor

## ■ Connecting a DC Reactor

A DC reactor can be installed to drive models CIMR-E□2A0004 to 2A0081 and 4A0002 to 4A0044. When installing a DC reactor, ensure the jumper between terminals +1 and +2 (terminals are jumpered for shipment) is removed. The jumper must be installed if no DC reactor is used. Refer to [Figure 8.13](#) for an example of DC reactor wiring.

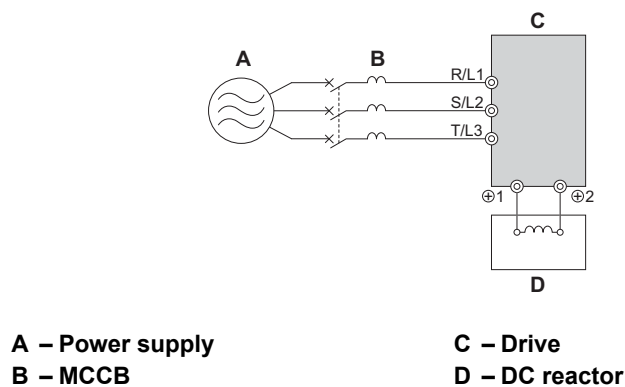


Figure 8.13 Connecting a DC Reactor

## ◆ Connecting a Surge Absorber

A surge absorber suppresses surge voltage generated from switching an inductive load near the drive. Inductive loads include magnetic contactors, relays, valves, solenoids, and brakes. Always use a surge absorber or diode when operating with an inductive load.

**Note:** Never connect a surge absorber to the drive output.

## ◆ Connecting a Noise Filter

### ■ Input-Side Noise Filter

Drive outputs generate noise as a result of high-speed switching. This noise flows from inside the drive back to the power supply, possibly affecting other equipment. Installing a noise filter to the input side of the drive can reduce the amount of noise flowing back into the power supply. This also prevents noise from entering the drive from the power supply.

- Use a noise filter specifically designed for AC drives.
- Install the noise filter as close as possible to the drive.





**Reducing Radiated and Radio Frequency Noise**

The drive, input lines, and output lines generate radio frequency noise. Use noise filters on input and output sides and install the drive in a metal enclosure panel to reduce radio frequency noise.

**Note:** The cable running between the drive and motor should be as short as possible.

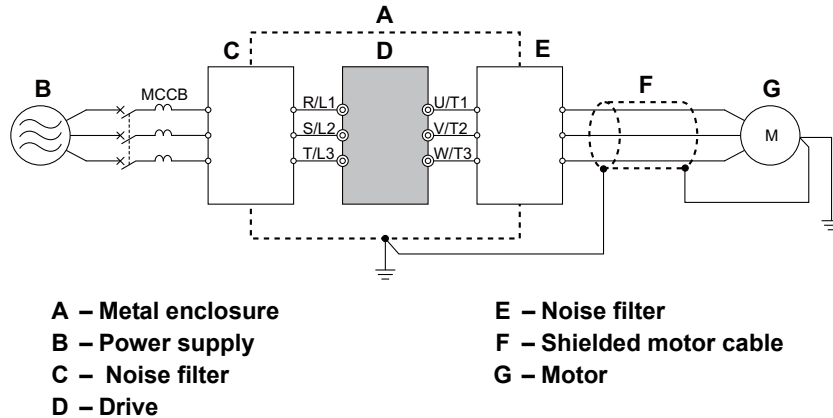


Figure 8.17 Reducing Radio Frequency Noise

◆ **Fuse/Fuse Holder**

■ **CIMR-E□2A0004 to 2A0415 and 4A0002 to 4A0675**

**NOTICE:** If a fuse is blown or an Earth Leakage Circuit Breaker (ELCB) is tripped, check the wiring and the selection of the peripheral devices. Check the wiring and the selection of peripheral devices to identify the cause. Contact Yaskawa before restarting the drive or the peripheral devices if the cause cannot be identified.

Yaskawa recommends installing a fuse to the input side of the drive to prevent damage to the drive if a short circuit occurs.

Select the appropriate fuse from the table below.

**Table 8.3 Input Fuses (CIMR-E□2A0004 to 2A0415, 4A0002 to 4A0675)**

Model CIMR-E□	Fuse Type		Fuse Holder		Fuse Type			
	Manufacturer: Fuji Electric						Manufacturer: Bussmann	
	Model	Fuse Ampere Rating	Model	Quantity	Model	Fuse Ampere Rating		
<b>Three-Phase 200 V Class</b>								
2A0004	CR2LS-30	30	CM-1A	1	FWH-70B	70		
2A0006	CR2LS-30	30	CM-1A	1	FWH-70B	70		
2A0008	CR2LS-30	30	CM-1A	1	FWH-70B	70		
2A0010	CR2LS-50	50	CM-1A	1	FWH-70B	70		
2A0012	CR2LS-50	50	CM-1A	1	FWH-70B	70		
2A0018	CR2LS-75	75	CM-1A	1	FWH-90B	90		
2A0021	CR2LS-100	100	CM-1A	1	FWH-90B	90		
2A0030	CR2L-125	125	CM-2A	1	FWH-100B	100		
2A0040	CR2L-150	150	CM-2A	1	FWH-200B	200		
2A0056	CR2L-175	175	CM-2A	1	FWH-200B	200		
2A0069	CR2L-225	225	–	–	FWH-200B	200		
2A0081	CR2L-260	260	–	–	FWH-300A	300		
2A0110	CR2L-300	300	–	–	FWH-300A	300		
2A0138	CR2L-350	350	–	–	FWH-350A	350		
2A0169	CR2L-400	400	–	–	FWH-400A	400		
2A0211	CR2L-450	450	–	–	FWH-400A	400		
2A0250	CR2L-600	600	–	–	FWH-600A	600		
2A0312	CR2L-600	600	–	–	FWH-700A	700		
2A0360	CR2L-600	600	–	–	FWH-800A	800		
2A0415	CR2L-600	600	–	–	FWH-1000A	1000		
<b>Three-Phase 400 V Class</b>								
4A0002	CR6L-20	20	CMS-4	3	FWH-40B	40		
4A0004	CR6L-30	30	CMS-4	3	FWH-50B	50		
4A0005	CR6L-50	50	CMS-4	3	FWH-70B	70		
4A0007	CR6L-50	50	CMS-4	3	FWH-70B	70		
4A0009	CR6L-50	50	CMS-4	3	FWH-90B	90		

## 8.5 Installing Peripheral Devices

Model CIMR-E□	Fuse Type		Fuse Holder		Fuse Type	
	Manufacturer: Fuji Electric				Manufacturer: Bussmann	
	Model	Fuse Ampere Rating	Model	Quantity	Model	Fuse Ampere Rating
4A0011	CR6L-50	50	CMS-4	3	FWH-90B	90
4A0018	CR6L-75	75	CMS-5	3	FWH-80B	80
4A0023	CR6L-75	75	CMS-5	3	FWH-100B	100
4A0031	CR6L-100	100	CMS-5	3	FWH-125B	125
4A0038	CR6L-150	150	CMS-5	3	FWH-200B	200
4A0044	CR6L-150	150	CMS-5	3	FWH-250A	250
4A0058	CR6L-200	200	–	–	FWH-250A	250
4A0072	CR6L-250	250	–	–	FWH-250A	250
4A0088	CR6L-250	250	–	–	FWH-250A	250
4A0103	CR6L-300	300	–	–	FWH-250A	250
4A0139	CR6L-350	350	–	–	FWH-350A	350
4A0165	CR6L-400	400	–	–	FWH-400A	400
4A0208	CS5F-600	600	–	–	FWH-500A	500
4A0250	CS5F-600	600	–	–	FWH-600A	600
4A0296	CS5F-600	600	–	–	FWH-700A	700
4A0362	CS5F-800	800	–	–	FWH-800A	800
4A0414	CS5F-800	800	–	–	FWH-800A	800
4A0515	CS5F-800	800	–	–	FWH-1000A	1000
4A0675	CS5F-1000	1000	–	–	FWH-1200A	1200

### ■ Wiring Fuses for the CIMR-E□4A0930 and 4A1200

**NOTICE:** If a fuse is blown or an Earth Leakage Circuit Breaker (ELCB) is tripped, check the wiring and the selection of the peripheral devices to identify the cause. Contact Yaskawa before restarting the drive or the peripheral devices if the cause cannot be identified.

A fuse should be installed on the input side to protect drive wiring and prevent other secondary damage. Wire the fuse so that leakage current in the upper controller power supply will trigger the fuse and shut off the power supply.

Select the appropriate fuse from [Table 8.4](#).

**Table 8.4 Input Fuses (CIMR-E□4A0930 and 4A1200)**

Voltage Class	Model CIMR-A□	Selection			Input Fuse (example)			
		Input Voltage (V)	Current (A)	Pre-arc $I^2t$ (A <sup>2</sup> s)	Model	Manufacturer	Rating	Pre-arc $I^2t$ (A <sup>2</sup> s)
Three-Phase 400 V Class	4A0930	480	1200	140000 to 3100000	CS5F-1200	Fuji Electric	AC500 V, 1200 A	276000
	4A1200	480	1500	320000 to 3100000	CS5F-1500		AC500 V, 1500 A	351000

### ◆ Attachment for External Heatsink (IP00/NEMA type1 Enclosure)

An external heatsink can be attached that projects outside the enclosure. Steps should be taken to ensure that there is enough air circulation around the heatsink.

Contact your Yaskawa sales representative or Yaskawa directly.

### ◆ EMC Filter Installation

This drive is tested according to European standards IEC61800-5-1 and complies with the EMC guidelines. [Refer to EMC Filter Installation on page 441](#) for details about EMC filter selection and installation.

### ◆ Installing a Motor Thermal Overload (oL) Relay on the Drive Output

Motor thermal overload relays protect the motor by disconnecting power lines to the motor due to a motor overload condition.

Install a motor thermal overload relay between the drive and motor:

- When operating multiple motors on a single AC drive.
- When using a power line bypass to operate the motor directly from the power line.

It is not necessary to install a motor thermal overload relay when operating a single motor from a single AC drive. The AC drive has UL recognized electronic motor overload protection built into the drive software.

- Note:**
1. Disable the motor protection function (L1-01 = 0) when using an external motor thermal overload relay.
  2. The relay should shut off main power on the input side of the main circuit when triggered.

## ■ General Precautions when Using Thermal Overload Relays

The following application precautions should be considered when using motor thermal overload relays on the output of AC drives in order to prevent nuisance trips or overheat of the motor at low speeds:

1. Low speed motor operation
2. Use of multiple motors on a single AC drive
3. Motor cable length
4. Nuisance tripping resulting from high AC drive carrier frequency

### Low Speed Operation and Motor Thermal oL Relays

Generally, thermal relays are applied on general-purpose motors. When general-purpose motors are driven by AC drives, the motor current is approximately 5% to 10% greater than if driven by a commercial power supply. In addition, the cooling capacity of a motor with a shaft-driven fan decreases when operating at low speeds. Even if the load current is within the motor rated value, motor overheating may occur. A thermal relay cannot effectively protect the motor due to the reduction of cooling at low speeds. For this reason, apply the UL recognized electronic thermal overload protection function built into the drive whenever possible.

**UL recognized electronic thermal overload function of the drive:** Speed-dependent heat characteristics are simulated using data from standard motors and force-ventilated motors. The motor is protected from overload using this function.

### Using a Single Drive to Operate Multiple Motors

Turn off the electronic thermal overload function. Please refer to the appropriate product instruction manual to determine which parameter disables this function.

**Note:** The UL recognized electronic thermal overload function cannot be applied when operating multiple motors with a single drive.

### Long Motor Cables

When a high carrier frequency and long motor cables are used, nuisance tripping of the thermal relay may occur due to increased leakage current. To avoid this, reduce the carrier frequency or increase the tripping level of the thermal overload relay.

### Nuisance Tripping Due to a High AC Drive Carrier Frequency

Current waveforms generated by high carrier frequency PWM drives tend to increase the temperature in overload relays. It may be necessary to increase the trip level setting when encountering nuisance triggering of the relay.

**WARNING! Fire Hazard.** Confirm an actual motor overload condition is not present prior to increasing the thermal oL trip setting. Check local electrical codes before making adjustments to motor thermal overload settings.



# Appendix: A

## Specifications

---

<b>A.1 THREE-PHASE 200 V CLASS DRIVES</b> .....	<b>350</b>
<b>A.2 THREE-PHASE 400 V CLASS DRIVES</b> .....	<b>351</b>
<b>A.3 DRIVE SPECIFICATIONS</b> .....	<b>352</b>
<b>A.4 DRIVE WATT LOSS DATA</b> .....	<b>353</b>
<b>A.5 DRIVE DERATING DATA</b> .....	<b>354</b>

# A.1 Three-Phase 200 V Class Drives

Table A.1 Power Ratings (Three-Phase 200 V Class)

Item		Specification																			
CIMR-E□2A		0004	0006	0008	0010	0012	0018	0021	0030	0040	0056	0069	0081	0110	0138	0169	0211	0250	0312	0360	0415
Maximum Applicable Motor Capacity (kW) <1>		0.7	1.1	1.5	2.2	3	3.7	5.5	7.5	11	15	18.5	22	30	37	45	55	75	90	110	110
Input	Input Current (A) <2>	3.9	7.3	8.8	10.8	13.9	18.5	24	37	52	68	80	96	111	136	164	200	271	324	394	471
	Rated Voltage Rated Frequency	Three-phase 200 to 240 Vac 50/60 Hz/270 to 340 Vdc <3>																			
	Allowable Voltage Fluctuation	-15 to 10%																			
	Allowable Frequency Fluctuation	±5%																			
	Input Power (kVA)	2.2	3.1	4.1	5.8	7.8	9.5	14	18	27	36	44	52	51	62	75	91	124	148	180	215
Output	Rated Output Capacity (kVA) <4>	1.3	2.3	3	3.7	4.6	6.7	8	11.4	15.2	21	26	31	42	53	64	80	95	119	137	158
	Rated Output Current (A) <5>	3.5	6	8	9.6	12	17.5	21	30	40	56	69	81	110	138	169	211	250	312	360	415
	Overload Tolerance	120% of rated output current for 60 s <b>Note:</b> Derating may be required for applications that start and stop frequently.																			
	Carrier Frequency	1 to 15 kHz <6>										1 to 10 kHz <6>									
	Maximum Output Voltage (V)	Three-phase 200 to 240 V (proportional to input voltage)																			
	Maximum Output Frequency (Hz)	200 Hz <6>																			

- <1> The motor capacity (kW) refers to a Yaskawa 4-pole motor. The rated output current of the drive output amps should be equal to or greater than the motor rated current.
- <2> Assumes operation at the rated output current. Input current rating varies depending on the power supply transformer, input reactor, wiring connections, and power supply impedance.
- <3> DC is not available for UL/CE standards.
- <4> Rated motor capacity is calculated with a rated output voltage of 220 V.
- <5> Current derating is required in order to raise the carrier frequency.
- <6> User adjustable

## A.2 Three-Phase 400 V Class Drives

Table A.2 Power Ratings (Three-Phase 400 V Class)

Item		Specification														
CIMR-E□4A		0002	0004	0005	0007	0009	0011	0018	0023	0031	0038	0044	0058	0072	0088	0103
Maximum Applicable Motor Capacity (kW) <1>		0.75	1.5	2.2	3	3.7	5.5	7.5	11	15	18.5	22	30	37	45	55
Input	Input Current (A) <2>	2.1	4.3	5.9	8.1	9.4	14	20	24	38	44	52	58	71	86	105
	Rated Voltage Rated Frequency	Three-phase 380 to 480 Vac 50/60 Hz/510 to 680 Vdc <3>														
	Allowable Voltage Fluctuation	-15 to 10%														
	Allowable Frequency Fluctuation	±5%														
Input Power (kVA)		2.3	4.3	6.1	8.1	10.0	14.5	19.4	28.4	37.5	46.6	54.9	53.0	64.9	78.6	96.0
Output	Rated Output Capacity (kVA) <4>	1.6	3.1	4.1	5.3	6.7	8.5	13.3	17.5	24	29	34	44	55	67	78
	Rated Output Current (A) <5>	2.1	4.1	5.4	6.9	8.8	11.1	17.5	23	31	38	44	58	72	88	103
	Overload Tolerance	120% of rated output current for 60 s <b>Note:</b> Derating may be required for applications that start and stop frequently.														
	Carrier Frequency	1 to 15 kHz <6>														
	Maximum Output Voltage (V)	Three-phase 380 to 480 V (proportional to input voltage)														
Maximum Output Frequency (Hz)		200 Hz <6>														

Item		Specification											
CIMR-E□4A		0139	0165	0208	0250	0296	0362	0414	0515	0675	0930	1200	
Maximum Applicable Motor Capacity (kW) <1>		75	90	110	132	160	185	220	250	355	500	630	
Input	Input Current (A) <2>	142	170	207	248	300	346	410	465	657	922	1158	
	Rated Voltage Rated Frequency	Three-phase 380 to 480 Vac 50/60 Hz/510 to 680 Vdc <3>											
	Allowable Voltage Fluctuation	-15 to 10%											
	Allowable Frequency Fluctuation	±5%											
Input Power (kVA)		129.9	155.5	189	227	274	316	375	416	601	843	1059	
Output	Rated Output Capacity (kVA) <4>	106	126	159	191	226	276	316	392	514	709	915	
	Rated Output Current (A) <5>	139	165	208	250	296	362	414	515	675	930	1200	
	Overload Tolerance	120% of rated output current for 60 s <b>Note:</b> Derating may be required for applications that start and stop frequently.											
	Carrier Frequency	1 to 10 kHz <6>					1 to 5 kHz <6>						
	Maximum Output Voltage (V)	Three-phase 380 to 480 V (proportional to input voltage)										<7>	
Maximum Output Frequency (Hz)		200 Hz <6>					150 Hz <6>						

- <1> The motor capacity (kW) refers to a Yaskawa 4-pole motor. The rated output current of the drive output amps should be equal to or greater than the motor rated current.
- <2> Assumes operation at the rated output current. Input current rating varies depending on the power supply transformer, input reactor, wiring conditions, and power supply impedance.
- <3> DC is not available for UL/CE standards.
- <4> Rated motor capacity is calculated with a rated output voltage of 440 V.
- <5> Current derating is required in order to raise the carrier frequency.
- <6> User adjustable
- <7> Maximum output voltage is  $0.95 \times [\text{input voltage}]$ .

## A.3 Drive Specifications

- Note:**
1. Perform rotational Auto-Tuning to obtain the performance specifications given below.
  2. For optimum performance life of the drive, install the drive in an environment that meets the required specifications.

Item		Specification
Control Characteristics	Control Method	The following control methods can be set using drive parameters: <ul style="list-style-type: none"> <li>• V/f Control (V/f)</li> <li>• Open Loop Vector Control for PM (OLV/PM)</li> </ul>
	Frequency Control Range	0.01 to 200 Hz
	Frequency Accuracy (Temperature Fluctuation)	Digital input: within $\pm 0.01\%$ of the max output frequency (-10 to +40°C) Analog input: within $\pm 0.1\%$ of the max output frequency (25°C $\pm 10^\circ\text{C}$ )
	Frequency Setting Resolution	Digital inputs: 0.01 Hz Analog inputs: 1/2048 of the maximum output frequency setting (11 bit plus sign)
	Output Frequency Resolution	0.001 Hz
	Frequency Setting Signal	-10 to 10 V, 0 to 10 V, 0 to 20 mA, 4 to 20 mA, Pulse Train Input
	Starting Torque	V/F: 150% at 3 Hz OLV/PM: 100% at 5% speed
	Speed Control Range	V/F: 1:40 OLV/PM: 1:20
	Speed Response	OLV/PM: 10 Hz
	Accel/Decel Time	0.0 to 6000.0 s (4 selectable combinations of independent acceleration and deceleration settings)
	Braking Torque	Approx. 20% $\langle 1 \rangle$
	V/f Characteristics	User-selected programs and V/f preset patterns possible
Main Control Functions	Momentary Power Loss Ride-Thru, Speed Search, Overtorque/Undertorque Detection, 8 Step Speed (max), Accel/decel Switch, S-curve Accel/decel, 3-wire Sequence, Auto-tuning, Dwell, Cooling Fan on/off Switch, Slip Compensation, Torque Compensation, Frequency Jump, Upper/lower Limits for Frequency Reference, DC Injection Braking at Start and Stop, Overexcitation Braking, High Slip Braking, PI Control (with sleep function or snooze function), Energy Saving Control, MEMOBUS/Modbus Comm. (RS-422/RS-485 max, 115.2 kbps), Fault Restart, DriveWorksEZ (customized function), Removable Terminal Block with Parameter Backup Function, KEB, Overexcitation Deceleration, Overvoltage Suppression, Motor Underload Detection, etc.	
Protection Functions	Motor Protection	Electronic thermal overload relay
	Momentary Overcurrent Protection	Drive stops when output current exceeds 175%
	Overload Protection	Drive stops after 60 s at 120% of rated output current $\langle 2 \rangle$
	Overvoltage Protection	200 V class: Stops when DC bus voltage exceeds approx. 410 V 400 V class: Stops when DC bus voltage exceeds approx. 820 V
	Undervoltage Protection	200 V class: Stops when DC bus voltage falls below approx. 190 V 400 V class: Stops when DC bus voltage falls below approx. 380 V
	Momentary Power Loss Ride-Thru	Immediately stop after 15 ms or longer power loss. $\langle 3 \rangle$ Continuous operation during power loss than 2 s (standard) $\langle 4 \rangle$
	Heatsink Overheat Protection	Thermistor
	Stall Prevention	Stall Prevention is available during acceleration, deceleration, and during run.
Environment	Ground Protection	Electronic circuit protection $\langle 5 \rangle$
	DC Bus Charge LED	Remains lit until DC bus voltage falls below 50 V
	Area of Use	Indoors
	Ambient Temperature	-10 to 40°C (NEMA Type 1 enclosure), -10 to 50°C (IP00 enclosure), up to 60°C with output current derating
	Humidity	95 RH% or less (no condensation)
	Storage Temperature	-20 to 60°C (short-term temperature during transportation)
Protection Design	Altitude	Up to 1000 $\langle 6 \rangle$
	Vibration / Shock	10 to 20 Hz: 9.8 m/s <sup>2</sup> $\langle 7 \rangle$ 20 to 55 Hz: 5.9 m/s <sup>2</sup> (2A0004 to 2A0211, 4A0002 to 4A1200) 2.0 m/s <sup>2</sup> (2A0250 to 2A0415, 4A0208 to 4A0675)
Protection Design		IP00 enclosure, IP20/NEMA Type 1 enclosure $\langle 8 \rangle$

- $\langle 1 \rangle$  Ensure that Stall Prevention is disabled during deceleration (L3-04 = 0), when using a regenerative converter, a regenerative unit. The default setting for the Stall Prevention function will interfere with the braking resistor.
- $\langle 2 \rangle$  Overload protection may be triggered when operating with 120% of the rated output current if the output frequency is less than 6 Hz.
- $\langle 3 \rangle$  May be shorter due to load conditions and motor speed.
- $\langle 4 \rangle$  A separate Momentary Power Loss Ride-Thru Unit is required for the drives CIMR-E□2A0004 through 2A0056 and 4A0002 through 4A0031 if the application needs to continue running during a momentary power loss up to 2 s.
- $\langle 5 \rangle$  Ground protection cannot be provided when the impedance of the ground fault path is too low, or when the drive is powered up while a ground fault is present at the output.
- $\langle 6 \rangle$  Up to 3000 m with output current and voltage derating. Refer to [Altitude Derating on page 356](#) for details.
- $\langle 7 \rangle$  Models CIMR-E□4A0930 and 4A1200 are rated at 5.9 m/s<sup>2</sup>.
- $\langle 8 \rangle$  Removing the top protective cover from a NEMA Type 1 enclosure drive voids the NEMA Type 1 protection but still keeps IP20 conformity. This is applicable to models CIMR-E□2A0004 to 2A0081 and 4A0002 to 4A0044.



## A.4 Drive Watt Loss Data

**Table A.3 Watt Loss 200 V Class Three-Phase Models**

Model Number CIMR-E□	Rated Amps (A)	Heatsink Loss (W)	Interior Unit Loss (W)	Total Loss (W)
2A0004	3.5	18.4	47	66
2A0006	6.0	31	51	82
2A0008	8.0	43	52	95
2A0010	9.6	57	58	115
2A0012	12.0	77	64	141
2A0018	17.5	101	67	168
2A0021	21	138	83	222
2A0030	30	262	117	379
2A0040	40	293	145	437
2A0056	56	371	175	546
2A0069	69	491	205	696
2A0081	81	527	257	785
2A0110	110	719	286	1005
2A0138	138	842	312	1154
2A0169	169	1014	380	1394
2A0211	211	1218	473	1691
2A0250	250	1764	594	2358
2A0312	312	2020	665	2686
2A0360	360	2698	894	3591
2A0415	415	2672	954	3626

**Table A.4 Watt Loss 400 V Class Three-Phase Models**

Model Number CIMR-E□	Rated Amps (A)	Heatsink Loss (W)	Interior Unit Loss (W)	Total Loss (W)
4A0002	2.1	19.8	48	68
4A0004	4.1	32	49	81
4A0005	5.4	45	53	97
4A0007	6.9	62	59	121
4A0009	8.8	66	60	126
4A0011	11.1	89	73	162
4A0018	17.5	177	108	285
4A0023	23	216	138	354
4A0031	31	295	161	455
4A0038	38	340	182	521
4A0044	44	390	209	599
4A0058	58	471	215	686
4A0072	72	605	265	870
4A0088	88	684	308	993
4A0103	103	848	357	1205
4A0139	139	1215	534	1749
4A0165	165	1557	668	2224
4A0208	208	1800	607	2408
4A0250	250	2379	803	3182
4A0296	296	2448	905	3353
4A0362	362	3168	1130	4298
4A0414	414	3443	1295	4738
4A0515	515	4850	1668	6518
4A0675	675	4861	2037	6898
4A0930	930	8476	2952	11428
4A1200	1200	8572	3612	12184

## A.5 Drive Derating Data

The drive can be operated at above the rated temperature, altitude, and default carrier frequency by derating the drive capacity.

### ◆ Carrier Frequency Derating

As the carrier frequency of the drive is increased above the factory default setting, the drive's rated output current must be derated according to [Figure A.1](#) to [Figure A.5](#).

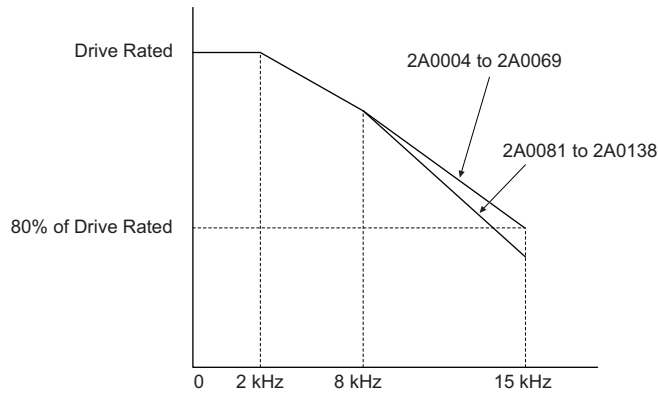


Figure A.1 Carrier Frequency Derating (CIMR-E□2A0004 to 2A0138)

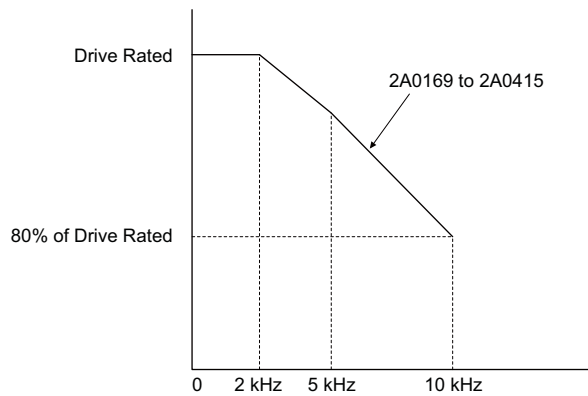


Figure A.2 Carrier Frequency Derating (CIMR-E□2A0169 to 2A0415)

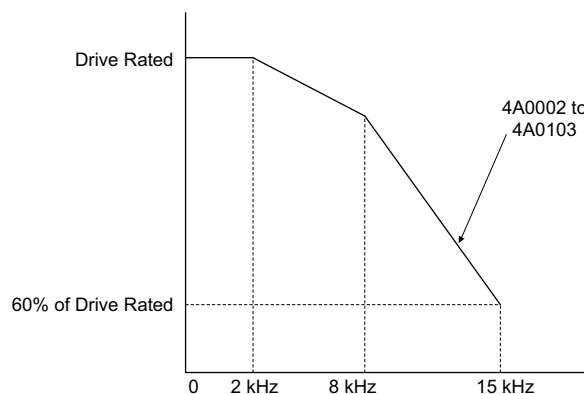


Figure A.3 Carrier Frequency Derating (CIMR-E□4A0002 to 4A0103)

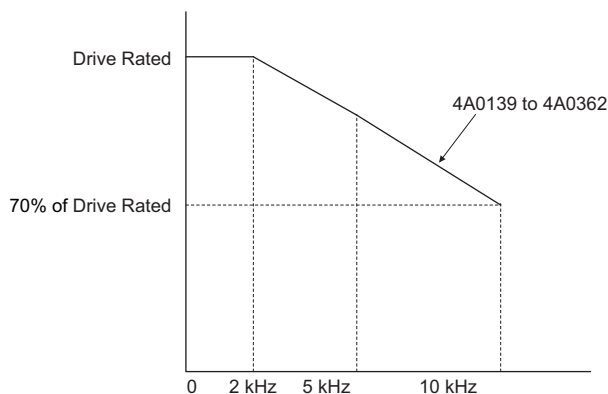


Figure A.4 Carrier Frequency Derating (CIMR-E□4A0139 to 4A0362)

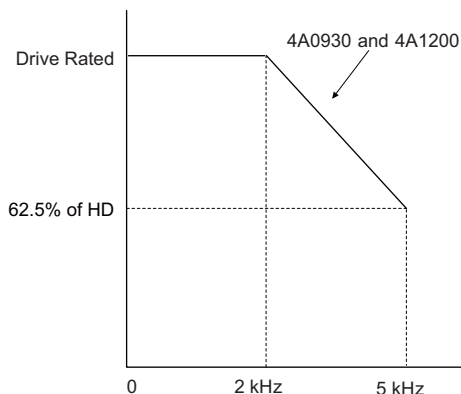


Figure A.5 Carrier Frequency Derating (CIMR-E□4A0930 and 4A1200)

### ◆ Temperature Derating

To ensure the maximum performance life, the drives output current must be derated like shown in *Figure A.6* when the drive is installed in areas with high ambient temperature or if drives are Side-by-Side mounted in a cabinet. In order to ensure reliable drive overload protection, the parameters L8-12 and L8-35 must also be set according to the installation conditions.

### ■ Parameter Settings

No.	Name	Description	Range	Def.
L8-12	Ambient Temperature Setting	Adjust the drive overload (oL2) protection level when the drive is installed in an environment that exceeds its ambient temperature rating.	-10 to 50	40°C
L8-35	Installation Method Selection	0: IP00 Enclosure 1: Side-by-Side Mounting 2: NEMA Type 1 Enclosure 3: Finless Drive or External Heatsink Installation	0 to 3	0

#### Setting: 0 IP00 Enclosure

Drive operation between -10°C and 50°C allows 100% continuous current without derating.

#### Setting: 1 Side-by-Side Mounting

Drive operation between -10°C and 30°C allows 100% continuous current without derating. Operation between 30°C and 50°C requires output current derating.

#### Setting: 2 NEMA Type 1 Enclosure

Drive operation between -10°C and 40°C allows 100% continuous current without derating. Operation between 40°C and 50°C requires output current derating.

#### Setting: 3 External Heatsink Installation, Finless Drive

Drive operation between -10°C and 40°C allows 100% continuous current without derating. Operation between 40°C and 50°C requires output current derating.

## A.5 Drive Derating Data

---

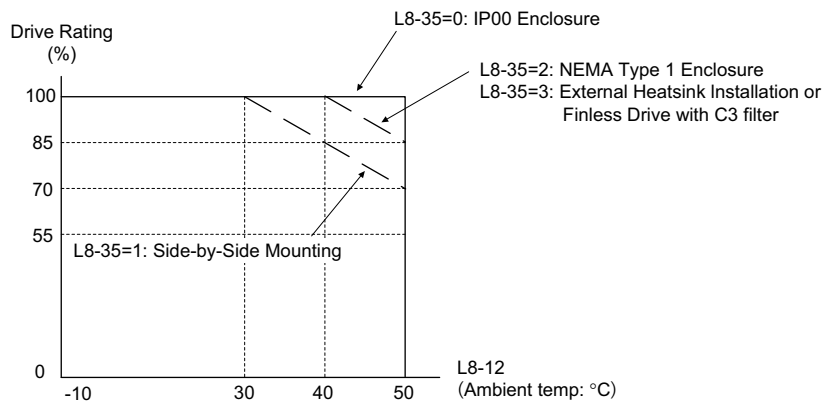


Figure A.6 Ambient Temperature and Installation Method Derating

---

### ◆ Altitude Derating

The drive standard ratings are valid for an installation altitude up to 1000 m. If the altitude exceeds 1000 m both the drive rated voltage and the rated output current must be derated for 1% per 100 m. The maximum altitude is 3000 m.

# Appendix: B

## Parameter List

---

This appendix contains a full listing of all parameters and settings available in the drive.

<b>B.1 UNDERSTANDING THE PARAMETER TABLE</b> .....	<b>358</b>
<b>B.2 PARAMETER GROUPS</b> .....	<b>359</b>
<b>B.3 PARAMETER TABLE</b> .....	<b>360</b>
<b>B.4 CONTROL MODE DEPENDENT PARAMETER DEFAULT VALUES</b> .....	<b>398</b>
<b>B.5 V/F PATTERN DEFAULT VALUES</b> .....	<b>399</b>
<b>B.6 DEFAULTS BY DRIVE MODEL SELECTION (O2-04)</b> .....	<b>400</b>
<b>B.7 PARAMETERS THAT CHANGE WITH THE MOTOR CODE SELECTION</b> .....	<b>404</b>





# B.1 Understanding the Parameter Table

### ◆ Control Modes, Symbols, and Terms

The table below lists terms and symbols used in this section to indicate which parameters are available in which control modes.

**Note:** For detailed instructions on each control mode, *Refer to Control Mode Selection on page 28.*

**Table B.1 Symbols and Icons Used in the Parameter Table**

Symbol	Description
	Indicates the parameter is accessible in all control modes.
	Parameter is available when operating the drive with V/f Control.
	Parameter is available when operating the drive with Open Loop Vector for PM motors.
	Indicates this parameter can be changed during run.

**Note:** If a parameter is not available in a certain control mode, the symbol for that control mode is grayed out.

## B.2 Parameter Groups

Parameter Group	Name	Page	Parameter Group	Name	Page
A1	Initialization Parameters	<a href="#">360</a>	H6	Pulse Train Input/Output	<a href="#">381</a>
A2	User Parameters	<a href="#">360</a>	L1 <I>	Motor Protection	<a href="#">382</a>
b1	Operation Mode Selection	<a href="#">361</a>	L2	Momentary Power Loss Ride-Thru	<a href="#">382</a>
b2	DC Injection Braking and Short Circuit Braking	<a href="#">362</a>	L3 <I>	Stall Prevention	<a href="#">383</a>
b3 <I>	Speed Search	<a href="#">362</a>	L4	Speed Detection	<a href="#">384</a>
b4	Timer Function	<a href="#">363</a>	L5	Fault Restart	<a href="#">385</a>
b5	PI Control	<a href="#">363</a>	L6	Torque Detection	<a href="#">385</a>
b8	Energy Saving	<a href="#">365</a>	L8 <I>	Drive Protection	<a href="#">385</a>
C1	Acceleration and Deceleration Times	<a href="#">366</a>	n1	Hunting Prevention	<a href="#">387</a>
C2	S-Curve Characteristics	<a href="#">366</a>	n3	High Slip Braking (HSB) and Overexcitation Braking	<a href="#">387</a>
C4	Torque Compensation	<a href="#">366</a>	n8	PM Motor Control Tuning	<a href="#">387</a>
C6 <I>	Carrier Frequency	<a href="#">367</a>	o1	Digital Operator Display Selection	<a href="#">388</a>
d1	Frequency Reference	<a href="#">367</a>	o2	Digital Operator Keypad Functions	<a href="#">389</a>
d2	Frequency Upper/Lower Limits	<a href="#">367</a>	o3	Copy Function	<a href="#">389</a>
d3	Jump Frequency	<a href="#">368</a>	o4	Maintenance Monitor Settings	<a href="#">389</a>
d4	Frequency Reference Hold and Up/Down 2 Function	<a href="#">368</a>	q	DriveWorksEZ Parameters	<a href="#">390</a>
d6	Field Weakening and Field Forcing	<a href="#">368</a>	r	DriveWorksEZ Connection Parameters	<a href="#">390</a>
d7	Offset Frequency	<a href="#">368</a>	T1	Induction Motor Auto-Tuning	<a href="#">390</a>
E1	V/f Pattern for Motor	<a href="#">368</a>	T2	PM Motor Auto-Tuning	<a href="#">391</a>
E2 <I>	Motor Parameters	<a href="#">369</a>	U1 <I>	Operation Status Monitors	<a href="#">391</a>
E5	PM Motor Settings	<a href="#">370</a>	U2 <I>	Fault Trace	<a href="#">393</a>
F6	Communication Option Card	<a href="#">371</a>	U3	Fault History	<a href="#">394</a>
H1	Multi-Function Digital Inputs	<a href="#">373</a>	U4 <I>	Maintenance Monitors	<a href="#">394</a>
H2	Multi-Function Digital Outputs	<a href="#">376</a>	U5	PI Monitors	<a href="#">396</a>
H3 <I>	Multi-Function Analog Inputs	<a href="#">378</a>	U6	Operation Status Monitors	<a href="#">396</a>
H4	Multi-Function Analog Outputs	<a href="#">380</a>	U8	DriveWorksEZ Monitors	<a href="#">397</a>
H5	MEMOBUS/Modbus Serial Communication	<a href="#">380</a>	–	–	–

<I> Specifications differ for models CIMR-E□4A0930 and 4A1200. Refer to [Parameter Differences for models CIMR-E□4A0930 and 4A1200 on page 359](#) for details.

### ◆ Parameter Differences for models CIMR-E□4A0930 and 4A1200



Parameter Group	Name	Difference
b3	Speed Search	Depends on the b3-04 setting. Refer to <a href="#">b3: Speed Search on page 362</a> for details.
C6	Carrier Frequency	Defaults and setting ranges differ for C6-02, C6-03, and C6-04. Refer to <a href="#">C6: Carrier Frequency on page 367</a> for details.
E2	Motor Parameters	Setting units differ for E2-05. Refer to <a href="#">E2: Motor Parameters on page 369</a> for details.
H3	Multi-Function Analog Inputs	H3-□□ = 17 is available in models CIMR-E□4A0930 and 4A1200.
L1	Motor Protection	L1-15, L1-16, L1-19 and L1-20 are available in models CIMR-E□4A0930 and 4A1200. Refer to <a href="#">L1: Motor Protection on page 382</a> for details.
L3	Stall Prevention	Refer to <a href="#">L3: Stall Prevention on page 383</a> for details.
L8	Drive Protection	L8-78 is available in models CIMR-E□4A0930 and 4A1200 only.
U1	Operation Status Monitors	<ul style="list-style-type: none"> <li>Setting units differ for U1-03. Refer to <a href="#">U1: Operation Status Monitors on page 391</a> for details.</li> <li>U1-29 is available in models CIMR-E□4A0930 and 4A1200.</li> </ul>
U2	Fault Trace	<ul style="list-style-type: none"> <li>Setting units differ for U2-05. Refer to <a href="#">U2: Fault Trace on page 393</a> for details.</li> <li>U2-27 and U2-28 are available in models CIMR-E□4A0930 and 4A1200.</li> </ul>
U4	Maintenance Monitors	<ul style="list-style-type: none"> <li>Setting units differ for U4-13. Refer to <a href="#">U4: Maintenance Monitors on page 394</a> for details.</li> <li>U4-32, U4-37, U4-38, and U4-39 are available in models CIMR-E□4A0930 and 4A1200.</li> </ul>

## B.3 Parameter Table

### ◆ A: Initialization Parameters

The A parameter group creates the operating environment for the drive. This includes the parameter Access Level, Motor Control Method, Password, User Parameters and more.

#### ■ A1: Initialization Parameters

No.(Addr.)	Name	Description	Setting	Page
A1-00 (100H)  <3>	Language Selection	<b>All Modes</b> 0: English 1: Japanese 7: Chinese	Default: 7 Min: 0 Max: 7	126
A1-01 (101H)  <2>	Access Level Selection	<b>All Modes</b> 0: View and set A1-01 and A1-04. U□-□□ parameters can also be viewed. 1: User Parameters (access to a set of parameters selected by the user, A2-01 to A2-32) 2: Advanced Access (access to view and set all parameters)	Default: 2 Min: 0 Max: 2	126
A1-02 (102H) <3>	Control Method Selection	<b>All Modes</b> 0: V/f Control 5: Open Loop Vector Control for PM	Min: 0 Max: 5	126
A1-03 (103H)	Initialize Parameters	<b>All Modes</b> 0: No initialization 1110: User Initialize (parameter values must be stored using parameter o2-03) 2220: 2-wire Initialization 3330: 3-wire Initialization 5550: oPE04 Reset	Default: 0 Min: 0 Max: 5550	127
A1-04 (104H)	Password	<b>All Modes</b> When the value set into A1-04 does not match the value set into A1-05, parameters A1-01 through A1-03, A1-06, and A2-01 through A2-32 cannot be changed.	Default: 0000 Min: 0000 Max: 9999	127
A1-05 (105H)	Password Setting			
A1-06 (127H)	Application Preset	<b>All Modes</b> 0: General-purpose 1: Water supply pump 3: Exhaust fan 4: HVAC fan 5: Compressor	Default: 0 Min: 0 Max: 5	129
A1-07 (128H)	DriveWorksEZ Function Selection	<b>All Modes</b> 0: DWEZ disabled 1: DWEZ enabled 2: Digital input (enabled when H1-□□ = 9F)	Default: 0 Min: 0 Max: 2	129

<2> Default setting value is dependent on the Application Preset selected with parameter A1-06.

<3> Parameter setting value is not reset to the default value when the drive is initialized.

#### ■ A2: User Parameters

No.(Addr.)	Name	Description	Setting	Page
A2-01 to A2-32 (106 to 125H)	User Parameters 1 to 32	<b>All Modes</b> Parameters that were recently edited are listed here. The user can also select parameters to appear here for quick access.	Default: <2> Min: A1-00 Max: o4-13	129
A2-33 (126H)	User Parameter Automatic Selection	<b>All Modes</b> 0: Parameters A2-01 through A2-32 are reserved for the user to create a list of User Parameters. 1: Save history of recently viewed parameters. Recently edited parameters will be saved to A2-17 through A2-32 for quick access.	Default: 1 <1> Min: 0 Max: 1	130

<1> Default setting value is dependent on parameter A1-06. This setting value is 0 when A1-06 = 0, and 1 when A1-06 does not equal 0.

<2> Default setting value is determined by the Application Preset selected with parameter A1-06.



## ◆ b: Application

Application parameters configure the source of the Run command, DC Injection Braking, Speed Search, timer functions, PI control, the Dwell function, Energy Savings, and a variety of other application-related settings.

### ■ b1: Operation Mode Selection

No.(Addr.)	Name	Description	Setting	Page
b1-01 (180H)	Frequency Reference Selection 1	<b>All Modes</b> 0: Operator Keypad 1: Analog Input Terminals 2: MEMOBUS/Modbus Communications 3: Option Card 4: Pulse Train Input	Default: 1 Min: 0 Max: 4	131
b1-02 (181H)	Run Command Selection 1	<b>All Modes</b> 0: Operator 1: Control Circuit Terminal 2: MEMOBUS/Modbus Communications 3: Option Card	Default: 1 Min: 0 Max: 3	132
b1-03 (182H)	Stopping Method Selection	<b>All Modes</b> 0: Ramp to Stop 1: Coast to Stop 2: DC Injection Braking to Stop 3: Coast to Stop with Timer	Default: 0 Min: 0 Max: 3	133
b1-04 (183H)	Reverse Operation Selection	<b>All Modes</b> 0: Reverse Operation Enabled. 1: Reverse Operation Disabled.	Default: 0 Min: 0 Max: 1	135
b1-06 (185H)	Digital Input Reading	<b>All Modes</b> 0: Read Once 1: Read Twice	Default: 1 Min: 0 Max: 1	135
b1-07 (186H)	LOCAL/REMOTE Run Selection	<b>All Modes</b> 0: Run Command must be cycled 1: Accept Run Command at the new source	Default: 0 Min: 0 Max: 1	135
b1-08 (187H)	Run Command Selection While in Programming Mode	<b>All Modes</b> 0: Disabled 1: Enabled 2: Prohibit entering Programing During Run.	Default: 0 Min: 0 Max: 2	136
b1-11 (1DFH)	Drive Delay Time Setting	<b>All Modes</b> The Drive will delay executing any run command until the b1-11 time has expired.	Default: 0 Min: 0 Max: 600 s	136
b1-14 (1C3H)	Phase Order Selection	<b>All Modes</b> 0: Standard Phase Order 1: Switched phase order (reverses the direction of the motor)	Default: 0 Min: 0 Max: 1	136
b1-15 (1C4H)	Frequency Reference Selection 2	<b>All Modes</b> Enabled when an input terminal set for "External Reference 1/2 Selection" (H1-□□ = 2) closes. 0: Operator Keypad 1: Analog Input Terminals 2: MEMOBUS/Modbus Communications 3: Option Card 4: Pulse Train Input	Default: 0 Min: 0 Max: 4	137
b1-16 (1C5H)	Run Command Selection 2	<b>All Modes</b> Enabled when a terminal set for "External Reference 1/2 Selection" (H1-□□ = 2) closes. 0: Operator Keypad 1: Analog Input Terminals 2: MEMOBUS/Modbus Communications 3: Option Card 4: Pulse Train Input	Default: 0 Min: 0 Max: 4	137
b1-17 (1C6H)	Run Command at Power Up	<b>All Modes</b> 0: Run Command at Power Up is Not Issued 1: Run Command at Power Up is Issued	Default: 0 Min: 0 Max: 1	137

## B.3 Parameter Table

### ■ b2: DC Injection Braking and Short Circuit Braking

No.(Addr.)	Name	Description	Setting	Page
b2-01 (189H)	DC Injection Braking Start Frequency	<b>All Modes</b> Sets the frequency at which DC Injection Braking, Short Circuit Braking or Zero Servo starts when "Ramp to stop" (b1-03 = 0) is selected.	Default: <10> Min: 0.0 Hz Max: 10.0 Hz	137
b2-02 (18AH)	DC Injection Braking Current	<b>All Modes</b> Sets the Motor DC Injection Braking Current as a percentage of the drive rated current.	Default: 50% Min: 0% Max: 100%	138
b2-03 (18BH)	DC Injection Braking Time at Start	<b>All Modes</b> Sets DC Injection Braking time at start. Disabled when set to 0.00 s.	Default: 0.00 s Min: 0.00 s Max: 10.00 s	138
b2-04 (18CH)	DC Injection Braking Time at Stop	<b>All Modes</b> Sets DC Injection Braking time at stop.	Default: <10> Min: 0.00 s Max: 10.00 s	138
b2-09 (1E1H)	Motor Pre-Heat Current 2	<b>V/f</b> <b>OLV/PM</b> Sets the Motor Pre-Heat Current 2 for multi-function input setting as a percentage of Motor rated current (E2-01).	Default: 5% Min: 0% Max: 100%	138
b2-12 (1BAH)	Short Circuit Brake Time at Start	<b>V/f</b> <b>OLV/PM</b> Sets the time for Short Circuit Braking operation at start. <7>	Default: 0.00 s Min: 0.00 s Max: 25.50 s	139
b2-13 (1BBH)	Short Circuit Brake Time at Stop	<b>V/f</b> <b>OLV/PM</b> Sets the Short Circuit Braking operation time at stop. <7>	Default: 0.50 s Min: 0.00 s Max: 25.50 s	139
b2-18 (177H)	Short Circuit Braking Current	<b>V/f</b> <b>OLV/PM</b> Determines the current level for Short Circuit Braking. Set as a percentage of the motor rated current.	Default: 100.0% Min: 0.0% Max: 200.0%	139

<7> A coasting motor may require a braking resistor circuit to bring the motor to a stop in the required time.

<10> Default setting is determined by the control mode (A1-02).

### ■ b3: Speed Search

No.(Addr.)	Name	Description	Setting	Page
b3-01 (191H)	Speed Search Selection at Start	<b>All Modes</b> 0: Disabled 1: Enabled	Default: 0 Min: 0 Max: 1	142
b3-02 (192H)	Speed Search Deactivation Current	<b>V/f</b> <b>OLV/PM</b> Sets the current level at which the speed is assumed to be detected and Speed Search is ended. Set as a percentage of the drive rated current.	Default: <10> Min: 0% Max: 200%	142
b3-03 (193H)	Speed Search Deceleration Time	<b>V/f</b> <b>OLV/PM</b> Sets output frequency reduction time during Speed Search.	Default: 2.0 s Min: 0.1 s Max: 10.0 s	142
b3-04 (194H)	V/f Gain during Speed Search	<b>V/f</b> <b>OLV/PM</b> Determines how much to lower the V/f ratio during Speed Search. Output voltage during Speed Search equals the V/f setting multiplied by b3-04. <b>Note:</b> Available in V/f Control for models CIMR-E□4A0930 and 4A1200.	Default: <9> Min: 10% Max: 100%	143
b3-05 (195H)	Speed Search Delay Time	<b>All Modes</b> When using an external contactor on the output side, b3-05 delays executing Speed Search after a momentary power loss to allow time for the contactor to close.	Default: 0.2 s Min: 0.0 s Max: 100.0 s	143
b3-06 (196H)	Output Current 1 during Speed Search	<b>V/f</b> <b>OLV/PM</b> Sets the current injected to the motor at the beginning of Speed Estimation Speed Search. Set as a coefficient for the motor rated current.	Default: <9> Min: 0.0 Max: 2.0	143
b3-10 (19AH)	Speed Search Detection Compensation Gain	<b>V/f</b> <b>OLV/PM</b> Sets the gain which is applied to the speed detected by Speed Estimation Speed Search before the motor is reaccelerated. Increase this setting if ov occurs when performing Speed Search after a relatively long period of baseblock.	Default: 1.05 Min: 1.00 Max: 1.20	143
b3-14 (19EH)	Bi-Directional Speed Search Selection	<b>V/f</b> <b>OLV/PM</b> 0: Disabled (uses the direction of the frequency reference) 1: Enabled (drive detects which way the motor is rotating)	Default: 1 Min: 0 Max: 1	143
b3-17 (1F0H)	Speed Search Restart Current Level	<b>V/f</b> <b>OLV/PM</b> Sets the Speed Search restart current level as a percentage of the drive rated current.	Default: 150% Min: 0% Max: 200%	143
b3-18 (1F1H)	Speed Search Restart Detection Time	<b>V/f</b> <b>OLV/PM</b> Sets the time to detect Speed Search restart.	Default: 0.10 s Min: 0.00 s Max: 1.00 s	144
b3-19 (1F2H)	Number of Speed Search Restarts	<b>All Modes</b> Sets the number of times the drive can attempt to restart when performing Speed Search.	Default: 3 Min: 0 Max: 10	144

No.(Addr.)	Name	Description	Setting	Page
b3-24 (1C0H)	Speed Search Method Selection	<div style="display: flex; justify-content: space-around;"> <span>V/f</span> <span>OLV/PM</span> </div> 0: Current Detection Speed Search 1: Speed Estimation Speed Search	Default: 0 Min: 0 Max: 1	144
b3-25 (1C8H)	Speed Search Wait Time	<div style="border: 1px solid black; padding: 2px; display: inline-block;">All Modes</div> Sets the time the must wait between each Speed Search restart attempt.	Default: 0.5 s Min: 0.0 s Max: 30.0 s	144
b3-27 (1C9H)	Start Speed Search Select	<div style="border: 1px solid black; padding: 2px; display: inline-block;">All Modes</div> 0: Triggered when a Run Command is Issued (Normal) 1: Triggered when an External Baseblock is Released	Default: 0 Min: 0 Max: 1	144

<9> Default setting value is dependent on the drive model (o2-04).

<10> Default setting is determined by the control mode (A1-02).



### ■ b4: Timer Function

No.(Addr.)	Name	Description	Setting	Page
b4-01 (1A3H)	Timer Function On-Delay Time	<div style="border: 1px solid black; padding: 2px; display: inline-block;">All Modes</div>	Default: 0.0 s Min: 0.0 s Max: 3000.0 s	144
b4-02 (1A4H)	Timer Function Off-Delay Time	Used to set the on-delay and off-delay times for a digital timer output (H2-□□=12). The output is triggered by a digital input programmed to H1-□□=18)	Default: 0.0 s Min: 0.0 s Max: 3000.0 s	144

### ■ b5: PI Control

No.(Addr.)	Name	Description	Setting	Page
b5-01 (1A5H)	PI Function Setting	<div style="border: 1px solid black; padding: 2px; display: inline-block;">All Modes</div> 0: PI Disabled 1: Output Frequency=PI Output 1 3: Output Frequency=Frequency Reference+PI Output 1	Default: 0 Min: 0 Max: 3	148
b5-02 (1A6H)	Proportional Gain Setting (P)	<div style="border: 1px solid black; padding: 2px; display: inline-block;">All Modes</div> Sets the proportional gain of the PI controller.	Default: 1.00 Min: 0.00 Max: 25.00	148
b5-03 (1A7H)	Integral Time Setting (I)	<div style="border: 1px solid black; padding: 2px; display: inline-block;">All Modes</div> Sets the integral time for the PI controller.	Default: 1.0 s Min: 0.0 s Max: 360.0 s	148
b5-04 (1A8H)	Integral Limit Setting	<div style="border: 1px solid black; padding: 2px; display: inline-block;">All Modes</div> Sets the maximum output possible from the integrator as a percentage of the maximum output frequency.	Default: 100.0% Min: 0.0% Max: 100.0%	148
b5-06 (1AAH)	PI Output Limit	<div style="border: 1px solid black; padding: 2px; display: inline-block;">All Modes</div> Sets the maximum output possible from the entire PI controller as a percentage of the maximum output frequency.	Default: 100.0% Min: 0.0% Max: 100.0%	148
b5-07 (1ABH)	PI Offset Adjustment	<div style="border: 1px solid black; padding: 2px; display: inline-block;">All Modes</div> Applies an offset to the PI controller output. Set as a percentage of the maximum output frequency.	Default: 0.0% Min: -100.0% Max: 100.0%	148
b5-08 (1ACH)	PI Primary Delay Time Constant	<div style="border: 1px solid black; padding: 2px; display: inline-block;">All Modes</div> Sets a low pass filter time constant on the output of the PI controller.	Default: 0.00 s Min: 0.00 s Max: 10.00 s	148
b5-09 (1ADH)	PI Output Level Selection	<div style="border: 1px solid black; padding: 2px; display: inline-block;">All Modes</div> 0: Normal Output (direct acting) 1: Reverse Output (reverse acting)	Default: 0 Min: 0 Max: 1	149
b5-10 (1AEH)	PI Output Gain Setting	<div style="border: 1px solid black; padding: 2px; display: inline-block;">All Modes</div> Sets the gain applied to the PI output.	Default: 1.00 Min: 0.00 Max: 25.00	149
b5-11 (1AFH)	PI Output Reverse Selection	<div style="border: 1px solid black; padding: 2px; display: inline-block;">All Modes</div> 0: Reverse Disabled 1: Reverse Enabled When using setting 1, make sure reverse operation is permitted by parameter b1-04.	Default: 0 Min: 0 Max: 1	149
b5-12 (1B0H)	PI Feedback Loss Detection Selection	<div style="border: 1px solid black; padding: 2px; display: inline-block;">All Modes</div> 0: Digital Output Only. 1: Feedback Loss Alarm 2: Feedback Loss Fault 3: Digital output only. Even if PI control is disabled by Digital Input. 4: Feedback Loss Alarm. Even if PI is disabled by Digital Input. 5: Feedback Loss Fault. Even if PI is disabled by Digital Input.	Default: 0 Min: 0 Max: 5	150
b5-13 (1B1H)	PI Feedback Loss Detection Level	<div style="border: 1px solid black; padding: 2px; display: inline-block;">All Modes</div> Sets the PI feedback loss detection level as a percentage of the maximum output frequency.	Default: 0% Min: 0% Max: 100%	150

## B.3 Parameter Table

No.(Addr.)	Name	Description	Setting	Page
b5-14 (1B2H)	PI Feedback Loss Detection Time	<b>All Modes</b> Sets a delay time for PI feedback loss.	Default: 1.0 s Min: 0.0 s Max: 25.5 s	151
b5-15 (1B3H)	PI Sleep Function Start Level	<b>All Modes</b> Sets the frequency level that triggers the sleep function.	Default: 0.0 Hz Min: 0.0 Hz Max: 200.0 Hz	152
b5-16 (1B4H)	PI Sleep Delay Time	<b>All Modes</b> Sets a delay time before the sleep function is triggered.	Default: 0.0 s Min: 0.0 s Max: 25.5 s	152
b5-17 (1B5H)	PI Accel/Decel Time	<b>All Modes</b> Sets the acceleration and deceleration time to PI setpoint.	Default: 0.0 s Min: 0.0 s Max: 6000.0 s	153
b5-18 (1DCH)	PI Setpoint Selection	<b>All Modes</b> 0: Disabled 1: Enabled	Default: 0 Min: 0 Max: 1	153
b5-19 (1DDH)	PI Setpoint Value	<b>All Modes</b> Sets the PI target value when b5-18 = 1. Set as a percentage of the maximum output frequency.	Default: 0.00% Min: 0.00% Max: 100.00%	153
b5-20 (1E2H)	PI Setpoint Scaling	<b>All Modes</b> 0: 0.01Hz units 1: 0.01% units (100% = max output frequency) 2: r/min (number of motor poles must entered) 3: User Defined (set scaling to b5-38 and b5-39)	Default: 1 Min: 0 Max: 3	153
b5-21 (1E3H)	PI Sleep Input Source	<b>All Modes</b> Input Source Selection for Sleep Function Mode 0: PI Setpoint 1: SFS Input 2: Snooze	Default: 1 Min: 0 Max: 2	154
b5-22 (1E4H)	PI Snooze Level	<b>All Modes</b> Sets the PI Snooze function start level as a percentage of maximum frequency.	Default: 0 Min: 0 Max: 100	154
b5-23 (1E5H)	PI Snooze Delay Time	<b>All Modes</b> Sets the PI Snooze function delay time in terms of seconds.	Default: 0 Min: 0 Max: 2600	154
b5-24 (1E6H)	PI Snooze Deactivation Level	<b>All Modes</b> When the PI feedback drops below this level, normal operation starts again. Sets as a percentage of maximum frequency.	Default: 0 Min: 0 Max: 100	154
b5-25 (1E7H)	PI Setpoint Boost Setting	<b>All Modes</b> Temporary increase of PI setpoint to create an overshoot of the intended PI setpoint	Default: 0 Min: 0 Max: 100	154
b5-26 (1E8H)	PI Maximum Boost Time	<b>All Modes</b> Sets maximum boost time when PI feedback does not reach Boost level. Snooze function starts when PI feedback exceeds Boost setting level or boost time expired.	Default: 0 Min: 0 Max: 2600	154
b5-27 (1E9H)	PI Snooze Feedback Level	<b>All Modes</b> PI Snooze mode will be activated when PI feedback is above this level. Sets as a percentage of maximum frequency.	Default: 60 Min: 0 Max: 100	154
b5-28 (1EAH)	PI Feedback Function Selection	<b>All Modes</b> 0: Disabled 1: Square Root	Default: 0 Min: 0 Max: 1	155
b5-29 (1EBH)	PI Square Root Gain	<b>All Modes</b> A multiplier applied to the square root of the feedback.	Default: 0.00 Min: 0.00 Max: 2.00	155
b5-30 (1ECH)	PI Feedback Offset	<b>All Modes</b> PI feedback offset. Sets as a percentage of maximum frequency.	Default: 0.00 Min: 0.00 Max: 100.00	155
b5-34 (19FH) 	PI Output Lower Limit	<b>All Modes</b> Sets the minimum output possible from the PI controller as a percentage of the maximum output frequency.	Default: 0.00% Min: -100.0% Max: 100.0%	155
b5-35 (1A0H) 	PI Input Limit	<b>All Modes</b> Limits the PI control input (deviation signal) as a percentage of the maximum output frequency. Acts as a bipolar limit.	Default: 1000.0% Min: 0% Max: 1000.0%	155
b5-36 (1A1H)	PI Feedback High Detection Level	<b>All Modes</b> Sets the PI feedback high detection level as a percentage of the maximum output frequency.	Default: 100% Min: 0% Max: 100%	151
b5-37 (1A2H)	PI Feedback High Detection Time	<b>All Modes</b> Sets the PI feedback high level detection delay time.	Default: 1.0 s Min: 0.0 s Max: 25.5 s	151
b5-38 (1FEH)	PI Setpoint User Display	<b>All Modes</b> Sets the display value of U5-01 and U5-04 when the maximum frequency is output.	Default: <5> Min: 1 Max: 60000	155

No.(Addr.)	Name	Description	Setting	Page
b5-39 (1FFH)	PI Setpoint Display Digits	<b>All Modes</b> 0: No decimal places 1: One decimal places 2: Two decimal places 3: Three decimal places	Default: <5> Min: 0 Max: 3	155
b5-40 (17FH)	Frequency Reference Monitor Content During PI	<b>All Modes</b> 0: Frequency Reference (U1-01) After PI 1: Frequency Reference (U1-01)	Default: 0 Min: 0 Max: 1	155
b5-41 (160H)	PI Unit Selection	<b>All Modes</b> 0: WC (Inch of Water) 1: PSI (lb/Sq inch) 2: GPM (Gallons/min) 3: F (Deg Fahrenheit) 4: CFM (Cubic ft/min) 5: CMH (Cubic M/h) 6: LPH (Liters/h) 7: LPS (Liters/s) 8: Bar (Bar) 9: Pa (Pascals) 10: C (Deg Celsius) 11: Mtr (Meters) 12: Ft (Feet) 13: LPN (Liters/min) 14: CMM (Cubic M/min)	Default: 0 Min: 0 Max: 14	156
b5-42 (161H) 	PI Output Monitor Calculation Method	<b>All Modes</b> 0: Linear unit 1: Square root unit 2: Quadratic unit 3: Cubic unit	Default: 0 Min: 0 Max: 3	157
b5-43 (162H) 	Custom PI Output Monitor Setting 1	<b>All Modes</b> U5-07,-08 show Custom PI output. U5-43 shows the upper 4digits and U5-44 shows the lower 4 digits.	Default: 0 Min: 0 Max: 9999	157
b5-44 (163H) 	Custom PI Output Monitor Setting 2	It shows 999999.99 maximum. b5-43 and b5-44 is used for setting maximum monitor value at maximum frequency.	Default: 0 Min: 0 Max: 99.99	157
b5-45 (164H) 	Custom PI Output Monitor Setting 3	<b>All Modes</b> b5-07,-08 show Custom PI output. B5-45 is used for setting the minimum display value at o speed. This function can be effective when b5-42 is set to 1 (Linear unit)	Default: 0 Min: 0 Max: 999.9	157
b5-46 (165H)	PI Setpoint Monitor Unit Selection	<b>All Modes</b> 0: WC (Inch of Water) 1: PSI (lb/Sq inch) 2: GPM (Gallons/min) 3: F (Deg Fahrenheit) 4: CFM (Cubic ft/min) 5: CMH (Cubic M/h) 6: LPH (Liters/h) 7: LPS (Liters/s) 8: Bar (Bar) 9: Pa (Pascals) 10: C (Deg Celsius) 11: Mtr (Meters) 12: Ft (Feet) 13: LPN (Liters/min) 14: CMM (Cubic M/min)	Default: 0 Min: 0 Max: 14	157
b5-47 (17DH)	Reverse Operation Selection 2 by PI Output	<b>All Modes</b> Reverse operation selection when b5-01 = 3 or 4. 0: Zero limit when PI output is a negative value. 1: Reverse operation when PI output is a negative value (Zero limit if the reverse operation is prohibited by b1-04).	Default: 1 Min: 0 Max: 1	158

<5> Default setting is dependent on PI setpoint scaling (b5-20).

### ■ b8: Energy Saving

No.(Addr.)	Name	Description	Setting	Page
b8-01 (1CCH)	Energy Saving Control Selection	<b>V/f</b> 0: Disabled 1: Enabled	Default: <10> Min: 0 Max: 1	158
b8-04 (1CFH)	Energy Saving Coefficient Value	<b>V/f</b> Determines the level of maximum motor efficiency. Setting range is 0.0 to 2000.0 maximum output up to 3.7 kW. Refer to <a href="#">Model Number and Nameplate Check on page 29</a> .	Default: <8> <9> Min: 0.00 Max: 655.00	158
b8-05 (1D0H)	Power Detection Filter Time	<b>V/f</b> Sets a time constant filter for output power detection.	Default: 20 ms Min: 0 ms Max: 2000 ms	159

## B.3 Parameter Table

No.(Addr.)	Name	Description	Setting	Page
b8-06 (1D1H)	Search Operation Voltage Limit	<div style="display: flex; justify-content: space-around;"> <span>V/f</span> <span>OLV/PM</span> </div> Sets the limit for the voltage search operation as a percentage of the motor rated voltage.	Default: 0% Min: 0% Max: 100%	159

- <4> Default setting is dependent on the control mode (A1-02), the drive model (o2-04).  
 <8> Parameter value changes automatically if E2-11 is manually changed or changed by Auto-Tuning.  
 <9> Default setting value is dependent on the drive model (o2-04).  
 <10> Default setting is determined by the control mode (A1-02).

### ◆ C: Tuning

C parameters are used to adjust the acceleration and deceleration times, S-curves, torque compensation, and carrier frequency selections.

#### ■ C1: Acceleration and Deceleration Times

No.(Addr.)	Name	Description	Setting	Page
C1-01 (200H) 	Acceleration Time 1	<div style="display: flex; justify-content: space-around;"> <span>All Modes</span> </div> Sets the time to accelerate from 0 to maximum frequency.	Default: 30.0 s Min: 0.0 s Max: 6000.0 s	160
C1-02 (201H) 	Deceleration Time 1	<div style="display: flex; justify-content: space-around;"> <span>All Modes</span> </div> Sets the time to decelerate from maximum frequency to 0.		160
C1-03 (202H) 	Acceleration Time 2	<div style="display: flex; justify-content: space-around;"> <span>All Modes</span> </div> Sets the time to accelerate from 0 to maximum frequency.		160
C1-04 (203H) 	Deceleration Time 2	<div style="display: flex; justify-content: space-around;"> <span>All Modes</span> </div> Sets the time to decelerate from maximum frequency to 0.		160
C1-09 (208H)	Fast Stop Time	<div style="display: flex; justify-content: space-around;"> <span>All Modes</span> </div> Sets the time for the Fast Stop function.	Default: 10.0 s Min: 0.0 s Max: 6000.0 s	161
C1-11 (20AH)	Accel/Decel Time Switching Frequency	<div style="display: flex; justify-content: space-around;"> <span>All Modes</span> </div> Sets the frequency for automatic switching of Accel/ Decel times.	Default: 0.0 Hz Min: 0.0 Hz Max: 200.0 Hz	161

#### ■ C2: S-Curve Characteristics

No.(Addr.)	Name	Description	Setting	Page
C2-01 (20BH)	S-Curve Characteristic at Accel Start	<div style="display: flex; justify-content: space-around;"> <span>All Modes</span> </div> The S-curve can be controlled at the four points shown below. <div style="text-align: center; margin-top: 10px;"> </div> <p>&lt;1&gt; S-Curve Characteristic at Decel Start/End are fixed to 0.20 s.</p>	Default: 0.20 s <10> Min: 0.00 s Max: 10.00 s	162
C2-02 (20CH)	S-Curve Characteristic at Accel End		Default: 0.20 s Min: 0.00 s Max: 10.00 s	162

- <10> Default setting is determined by the control mode (A1-02).

#### ■ C4: Torque Compensation

No.(Addr.)	Name	Description	Setting	Page
C4-01 (215H) 	Torque Compensation Gain	<div style="display: flex; justify-content: space-around;"> <span>V/f</span> <span>OLV/PM</span> </div> Sets the gain for the automatic torque (voltage) boost function and helps to produce better starting torque.	Default: <10> Min: 0.00 Max: 2.50	162
C4-02 (216H) 	Torque Compensation Primary Delay Time	<div style="display: flex; justify-content: space-around;"> <span>V/f</span> <span>OLV/PM</span> </div> Sets the torque compensation filter time.	Default: <16> Min: 0 ms Max: 60000 ms	163

- <10> Default setting is determined by the control mode (A1-02).  
 <16> Default setting is determined by the control mode (A1-02) and the drive model (o2-04).

### ■ C6: Carrier Frequency

No.(Addr.)	Name	Description	Setting	Page
C6-02 (224H)	Carrier Frequency Selection	<p><b>All Modes</b></p> <p>1: 2.0 kHz                      2: 5.0 kHz                      3: 8.0 kHz                      4: 10.0 kHz                      5: 12.5 kHz                      6: 15.0 kHz                      7: Swing PWM1 (Audible sound 1)                      8: Swing PWM2 (Audible sound 2)                      9: Swing PWM3 (Audible sound 3)                      A: Swing PWM4 (Audible sound 4)                      B to E: No setting possible                      F: User defined (determined by C6-03 through C6-05)  <b>Note:</b> The available settings are 1, 2, and F for models CIMR-E□4A0930 and 4A1200.</p>	Default: <4> Min: 1 Max: F	163
C6-03 (225H)	Carrier Frequency Upper Limit	<p><b>All Modes</b></p> <p><b>Note:</b> C6-04 and C6-05 are available only in V/f control mode. Determines the upper and lower limits for the carrier frequency. In OLV, C6-03 determines the upper limit of the carrier frequency.</p>	Default: <13> Min: 1.0 kHz Max: 15.0 kHz	163
C6-04 (226H)	Carrier Frequency Lower Limit	<p>Carrier Frequency</p> <p>C6-03</p> <p>C6-04</p> <p>Output Frequency: × (C6-05) × K</p> <p>E1-04 Max Output Frequency</p> <p>Output Frequency</p>	Default: <13> Min: 1.0 kHz Max: 15.0 kHz	163
C6-05 (227H)	Carrier Frequency Proportional Gain		<p><b>Note:</b> The setting range is 1.0 to 5.0 kHz for models CIMR-E□4A0930 and 4A1200.</p>	Default: <13> Min: 0 Max: 99

<4> Default setting is dependent on the control mode (A1-02), the drive model (o2-04).

<13> Default setting value is dependent on the carrier frequency selection (C6-02).

### ◆ d: Reference Settings

Reference parameters are used to set the various frequency reference values during operation.

#### ■ d1: Frequency Reference

No.(Addr.)	Name	Description	Setting	Page
d1-01 (280H) ◀▶ RUN	Frequency Reference 1	<p><b>All Modes</b></p> <p>Sets the frequency reference for the drive. Setting units are determined by parameter o1-03.</p>	Default: 0.00 Hz Min: 0.00 Hz Max: 200.00 Hz <20>	165
d1-02 (281H) ◀▶ RUN	Frequency Reference 2			165
d1-03 (282H) ◀▶ RUN	Frequency Reference 3			165
d1-04 (283H) ◀▶ RUN	Frequency Reference 4			165
d1-17 (292H) ◀▶ RUN	Jog Frequency Reference	<p><b>All Modes</b></p> <p>Sets the jog frequency reference. Setting units are determined by parameter o1-03.</p>	Default: 6.00 Hz Min: 0.00 Hz Max: 200.00 Hz <20>	165

<20> Range upper limit is determined by the maximum output frequency (E1-04) and the upper limit of the frequency reference (d2-01).

#### ■ d2: Frequency Upper/Lower Limits

No.(Addr.)	Name	Description	Setting	Page
d2-01 (289H)	Frequency Reference Upper Limit	<p><b>All Modes</b></p> <p>Sets the frequency reference upper limit as a percentage of the maximum output frequency.</p>	Default: 100.0% Min: 0.0% Max: 110.0%	166
d2-02 (28AH)	Frequency Reference Lower Limit	<p><b>All Modes</b></p> <p>Sets the frequency reference lower limit as a percentage of the maximum output frequency.</p>	Default: 0.0% Min: 0.0% Max: 110.0%	166

## B.3 Parameter Table

No.(Addr.)	Name	Description	Setting	Page
d2-03 (293H)	Master Speed Reference Lower Limit	<p><b>All Modes</b></p> <p>Sets the lower limit for frequency references from analog inputs as a percentage of the maximum output frequency.</p>	Default: 0.0% Min: 0.0 Max: 110.0%	167

### ■ d3: Jump Frequency

No.(Addr.)	Name	Description	Setting	Page
d3-01 (294H)	Jump Frequency 1	<p><b>All Modes</b></p>	Default: 0.0 Hz Min: 0.0 Hz Max: 200.0 Hz	167
d3-02 (295H)	Jump Frequency 2	Eliminates problems with resonant vibration of the motor/machine by avoiding continuous operation in predefined frequency ranges. The drive accelerates and decelerates the motor through the prohibited frequency ranges. Setting 0.0 disables this function. Parameters must be set so that $d3-01 \geq d3-02 \geq d3-03$ .		167
d3-03 (296H)	Jump Frequency 3			167
d3-04 (297H)	Jump Frequency Width	<p><b>All Modes</b></p> <p>Sets the dead-band width around each selected prohibited frequency reference point.</p>	Default: 1.0 Hz Min: 0.0 Hz Max: 20.0 Hz	167

<10> Default setting is determined by the control mode (A1-02).

### ■ d4: Frequency Reference Hold and Up/Down 2 Function

No.(Addr.)	Name	Description	Setting	Page
d4-01 (298H)	Frequency Reference Hold Function Selection	<p><b>All Modes</b></p> <p>0: Disabled. Drive starts from zero when the power is switched on. 1: Enabled. At power up, the drive starts the motor at the Hold frequency that was saved.</p>	Default: 0 Min: 0 Max: 1	167
d4-10 (2B6H)	Up/Down Frequency Reference Limit Selection	0: Lower Limit is Determined by d2-02 or Analog Input 1: Lower Limit is Determined by d2-02	Default: 0 Min: 0 Max: 1	168

### ■ d6: Field Weakening and Field Forcing

No.(Addr.)	Name	Description	Setting	Page
d6-01 (2A0H)	Field Weakening Level	<p><b>V/f</b>   <b>OLV/PM</b></p> <p>Sets the drive output voltage for the Field Weakening function as a percentage of the maximum output voltage. Enabled when a multi-function input is set for Field Weakening (H1-□□ = 63).</p>	Default: 80% Min: 0% Max: 100%	169
d6-02 (2A1H)	Field Weakening Frequency Limit	<p><b>V/f</b>   <b>OLV/PM</b></p> <p>Sets the lower limit of the frequency range where Field Weakening control is valid. The Field Weakening command is valid only at frequencies above this setting and only when the output frequency matches the frequency reference (speed agree).</p>	Default: 0.0 Hz Min: 0.0 Hz Max: 200.0 Hz	169

### ■ d7: Offset Frequency

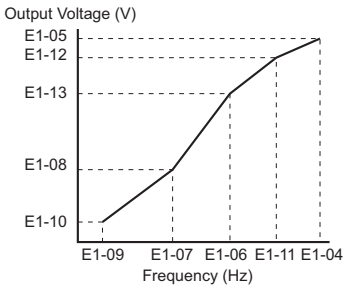
No.(Addr.)	Name	Description	Setting	Page
d7-01 (2B2H) RUN	Offset Frequency 1	<p><b>All Modes</b></p> <p>Added to the frequency reference when the digital input "Frequency offset 1" (H1-□□ = 44) is switched on.</p>	Default: 0.0% Min: -100.0% Max: 100.0%	169
d7-02 (2B3H) RUN	Offset Frequency 2	<p><b>All Modes</b></p> <p>Added to the frequency reference when the digital input "Frequency offset 2" (H1-□□ = 45) is switched on.</p>	Default: 0.0% Min: -100.0% Max: 100.0%	169
d7-03 (2B4H) RUN	Offset Frequency 3	<p><b>All Modes</b></p> <p>Added to the frequency reference when the digital input "Frequency offset 3" (H1-□□ = 46) is switched on.</p>	Default: 0.0% Min: -100.0% Max: 100%	169

## ◆ E: Motor Parameters

### ■ E1: V/f Pattern

No.(Addr.)	Name	Description	Setting	Page
E1-01 (300H)	Input Voltage Setting	<p><b>All Modes</b></p> <p>This parameter must be set to the power supply voltage. <b>WARNING!</b> Drive input voltage (not motor voltage) must be set in E1-01 for the protective features of the drive to function properly. Failure to do so may result in equipment damage and/or death or personal injury.</p>	Default: 200 V <18> Min: 155 V Max: 255 V	170



No.(Addr.)	Name	Description	Setting	Page
E1-03 (302H)	V/f Pattern Selection	<p><b>V/f</b> <b>OLV/PM</b></p> <p>0: 50 Hz, Constant torque 1                      1: 60 Hz, Constant torque 2                      2: 60 Hz, Constant torque 3 (50 Hz base)                      3: 72 Hz, Constant torque 4 (60 Hz base)                      4: 50 Hz, Variable torque 1                      5: 50 Hz, Variable torque 2                      6: 60 Hz, Variable torque 3                      7: 60 Hz, Variable torque 4                      8: 50 Hz, High starting torque 1                      9: 50 Hz, High starting torque 2                      A: 60 Hz, High starting torque 3                      B: 60 Hz, High starting torque 4                      C: 90 Hz (60 Hz base)                      D: 120 Hz (60 Hz base)                      E: 180 Hz (60 Hz base)                      F: Custom V/f, E1-04 through E1-13 settings define the V/f pattern</p>	Default: F <3> Min: 0 Max: F	170
E1-04 (303H)	Maximum Output Frequency	<p><b>All Modes</b></p> <p>These parameters are only applicable when E1-03 is set to F.                      To set linear V/f characteristics, set the same values for E1-07 and E1-09. In this case, the setting for E1-08 will be disregarded. Ensure that the four frequencies are set according to these rules:  <math>E1-09 \leq E1-07 &lt; E1-06 \leq E1-11 \leq E1-04</math>                      Note that if E1-11 = 0, then both E1-11 and E1-12 are disabled, and the above conditions do not apply.</p> 	Default: <4> <14> Min: 40.0 Max: 200.0	174
E1-05 (304H)	Maximum Voltage		Default: <4> <14> <18> Min: 0.00 V Max: 255.0 V <18>	174
E1-06 (305H)	Base Frequency		Default: <4> <14> Min: 0.0 Max: E1-04	174
E1-07 (306H)	Middle Output Frequency		Default: <4> Min: 0.0 Max: E1-04	174
E1-08 (307H)	Middle Output Frequency Voltage		Default: <4> <18> Min: 0.0 V Max: 255.0 V <18>	174
E1-09 (308H)	Minimum Output Frequency		Default: <4> <14> Min: 0.0 Max: E1-04	174
E1-10 (309H)	Minimum Output Frequency Voltage		Default: <4> <18> Min: 0.0 V Max: 255.0 V <18>	174
E1-11 (30AH) <21>	Middle Output Frequency 2		Default: 0.0 Hz Min: 0.0 Max: E1-04	174
E1-12 (30BH) <21>	Middle Output Frequency Voltage 2		Default: 0.0 V Min: 0.0 V Max: 255.0 V <18>	174
E1-13 (30CH)	Base Voltage		Default: 0.0 V <18> <27> Min: 0.0 V Max: 255.0 V <18>	174

- <3> Parameter setting value is not reset to the default value when the drive is initialized.
- <4> Default setting is dependent on the control mode (A1-02), the drive model (o2-04).
- <14> Default setting value is dependent on the motor code set to E5-01.
- <18> Values shown here are for 200 V class drives. Double the value when using a 400 V class drive.
- <21> Parameter ignored when E1-11 (Motor 1 Mid Output Frequency 2) and E1-12 (Motor 1 Mid Output Frequency Voltage 2) are set to 0.0.
- <27> When Auto-Tuning is performed, E1-13 and E1-05 will be set to the same value.
- <29> The setting range varies according to the motor code entered to E5-01 when using OLV/PM.

## E2: Motor Parameters

No.(Addr.)	Name	Description	Setting	Page
E2-01 (30EH)	Motor Rated Current	<p><b>V/f</b> <b>OLV/PM</b></p> <p>Sets the motor nameplate full load current in Amps. Automatically set during Auto-Tuning.</p>	Default: <9> Min: 10% of drive rated current Max: 200% of drive rated current <19>	174
E2-02 (30FH)	Motor Rated Slip	<p><b>V/f</b> <b>OLV/PM</b></p> <p>Sets the motor rated slip. Automatically set during Auto-Tuning.</p>	Default: <9> Min: 0.00 Hz Max: 20.00 Hz	175
E2-03 (310H)	Motor No-Load Current	<p><b>V/f</b> <b>OLV/PM</b></p> <p>Sets the no-load current for the motor. Automatically set during Auto-Tuning.</p>	Default: <9> Min: 0 A Max: E2-01 <19>	175
E2-04 (311H)	Number of Motor Poles	<p><b>V/f</b> <b>OLV/PM</b></p> <p>Sets the number of motor poles. Automatically set during Auto-Tuning.</p>	Default: 4 Min: 2 Max: 48	175
E2-05 (312H)	Motor Line-to-Line Resistance	<p><b>V/f</b> <b>OLV/PM</b></p> <p>Sets the phase-to-phase motor resistance. Automatically set during Auto-Tuning.  <b>Note:</b> The units are expressed in mΩ in models CIMR-E□4A0930 and 4A1200.</p>	Default: <9> Min: 0.000 Ω Max: 65.000 Ω	175
E2-10 (317H)	Motor Iron Loss for Torque Compensation	<p><b>V/f</b> <b>OLV/PM</b></p> <p>Sets the motor iron loss.</p>	Default: <9> Min: 0 W Max: 65535 W	175

## B.3 Parameter Table

No.(Addr.)	Name	Description	Setting	Page
E2-11 (318H)	Motor Rated Power	<p><input type="checkbox"/> V/f <input checked="" type="checkbox"/> OLV/PM</p> <p>Sets the motor rated power in kilowatts (1 HP = 0.746 kW). Automatically set during Auto-Tuning.  <b>Note:</b> This value's number of decimal places depends on the motor capacity. The value will have two decimal places (0.01 kW) when using the motor less than 300 kW and one decimal place (0.1 kW) when using the motor higher than 300 kW.</p>	Default: <9> Min: 0.00 kW Max: 650.00 kW	176

<9> Default setting value is dependent on the drive model (o2-04).

<19> This value's number of decimal places depends on the drive model. The value will have two decimal places (0.01 A) if the drive model is CIMR-E□2A0004 to 2A0040, 4A0002 to 4A0023 and one decimal place (0.1 A) if the drive model is CIMR-E□2A0056 to 2A0415, 4A0031 to 4A1200.

### ■ E5: PM Motor Settings

No.(Addr.)	Name	Description	Setting	Page
E5-01 (329H) <3>	Motor Code Selection	<p><input type="checkbox"/> V/f <input checked="" type="checkbox"/> OLV/PM</p> <p>Enter the Yaskawa motor code for the PM motor being used. Various motor parameters are automatically set based on the value of this parameter. Setting that were changed manually will be overwritten by the defaults of the selected motor code.  <b>Note:</b> Set to FFFF when using a non-Yaskawa PM motor or a special motor.</p>	Default: <4> <23> Min: 0000 Max: FFFF <28>	177
E5-02 (32AH) <3>	Motor Rated Power	<p><input type="checkbox"/> V/f <input checked="" type="checkbox"/> OLV/PM</p> <p>Sets the rated capacity of the motor.  <b>Note:</b> This value's number of decimal places depends on the motor capacity. The value will have two decimal places (0.01 kW) when using the motor less than 300 kW and one decimal place (0.1 kW) when using the motor higher than 300 kW.</p>	Default: <14> Min: 0.10 kW Max: 650.00 kW	177
E5-03 (32BH) <3>	Motor Rated Current	<p><input type="checkbox"/> V/f <input checked="" type="checkbox"/> OLV/PM</p> <p>Sets the motor rated current.</p>	Default: <14> Min: 10% of drive rated current Max: 200% of drive rated current <19>	177
E5-04 (32CH) <3>	Number of Motor Poles	<p><input type="checkbox"/> V/f <input checked="" type="checkbox"/> OLV/PM</p> <p>Sets the number of motor poles.</p>	Default: <14> Min: 2 Max: 48	177
E5-05 (32DH) <3>	Motor Stator Resistance	<p><input type="checkbox"/> V/f <input checked="" type="checkbox"/> OLV/PM</p> <p>Set the resistance for each motor phase.</p>	Default: <14> Min: 0.000 Ω Max: 65.000 Ω	178
E5-06 (32EH) <3>	Motor d-Axis Inductance	<p><input type="checkbox"/> V/f <input checked="" type="checkbox"/> OLV/PM</p> <p>Sets the d-axis inductance for the PM motor.</p>	Default: <14> Min: 0.00 mH Max: 300.00 mH	178
E5-07 (32FH) <3>	Motor q-Axis Inductance	<p><input type="checkbox"/> V/f <input checked="" type="checkbox"/> OLV/PM</p> <p>Sets the q-axis inductance for the PM motor.</p>	Default: <14> Min: 0.00 mH Max: 600.00 mH	178
E5-09 (331H) <3>	Motor Induction Voltage Constant 1	<p><input type="checkbox"/> V/f <input checked="" type="checkbox"/> OLV/PM</p> <p>Set the induced phase peak voltage in units of 0.1 mV (rad/s) [electrical angle]. Set this parameter when using a Yaskawa SSR1 Series PM motor with derated torque. When setting this parameter, E5-24 should be set to 0.</p>	Default: <14> Min: 0.0 mV/(rad/s) Max: 2000.0 mV/(rad/s)	178
E5-24 (353H) <3>	Motor Induction Voltage Constant 2	<p><input type="checkbox"/> V/f <input checked="" type="checkbox"/> OLV/PM</p> <p>Set the induced phase-to-phase rms voltage in units of 0.1 mV/(r/min) [mechanical angle]. Set this parameter when using a Yaskawa SMRA Series SPM motor. When setting this parameter, E5-09 should be set to 0.</p>	Default: <14> Min: 0.0 mV/(r/min) Max: 6500.0 mV/(r/min)	178
E5-25 (35EH) <51>	Polarity Judge Selection	<p><input type="checkbox"/> V/f <input checked="" type="checkbox"/> OLV/PM</p> <p>0: Positive Polarity 1: Negative Polarity</p>	Default: 0 Min: 0 Max: 1	178

<3> Parameter setting value is not reset to the default value when the drive is initialized.

<4> Default setting is dependent on the control mode (A1-02), the drive model (o2-04).

<14> Default setting value is dependent on the motor code set to E5-01.

<19> This value's number of decimal places depends on the drive model. The value will have two decimal places (0.01 A) if the drive model is CIMR-E□2A0004 to 2A0040, 4A0002 to 4A0023 and one decimal place (0.1 A) if the drive model is CIMR-E□2A0056 to 2A0415, 4A0031 to 4A1200.

<23> If using a Yaskawa SMRA Series SPM Motor, the default setting is 1800 r/min.

<28> Selection may vary depending on the motor code entered to E5-01.

<51> This parameter is valid from the drive software version S3801 and later.

## ◆ F: Options

### ■ F6: Communication Option Card

F6-01 through F6-03, F6-07 and F6-08 are common settings used for CC-Link <1>, CANopen <1>, DeviceNet <1>, PROFIBUS-DP <1>, and MECHATROLINK-II <1> option cards. Other parameters in the F6 group are used for communication protocol specific settings.

For more details on a specific option card, refer to the instruction manual for the option card.

<1> Under Development

No.(Addr.)	Name	Description	Setting	Page
F6-01 (3A2H)	Communications Error Operation Selection	<b>All Modes</b> 0: Ramp to stop. Decelerate to stop using the deceleration time in C1-02. 1: Coast to stop. 2: Fast Stop. Decelerate to stop using the deceleration time in C1-09. 3: Alarm only.	Default: 1 Min: 0 Max: 3	179
F6-02 (3A3H)	External Fault from Comm. Option Detection Selection	<b>All Modes</b> 0: Always detected 1: Detection during run only	Default: 0 Min: 0 Max: 1	179
F6-03 (3A4H)	External Fault from Comm. Option Operation Selection	<b>All Modes</b> 0: Ramp to stop. Decelerate to stop using the deceleration time in C1-02. 1: Coast to stop. 2: Fast Stop. Decelerate to stop using the deceleration time in C1-09. 3: Alarm only.	Default: 1 Min: 0 Max: 3	179
F6-04 (3A5H)	bUS Error Detection Time	<b>All Modes</b> Set the delay time for error detection if a bus error occurs.	Default: 2.0 s Min: 0.0 s Max: 5.0 s	–
F6-07 (3A8H)	Multi-Step Speed Enable/Disable Selection when NefRef/ComRef is Selected	<b>All Modes</b> 0: Multi-step Speed Operation disabled 1: Multi-step Speed Operation enabled	Default: 0 Min: 0 Max: 1	179
F6-08 (36AH) <1>	Reset Communication Parameters	<b>All Modes</b> 0: Do not reset parameters F6-□□ when the drive is initialized with A1-03. 1: Reset F6-□□ when the drive is initialized with A1-03.	Default: 0 Min: 0 Max: 1	180
F6-10 (3B6H)	CC-Link Node Address	<b>All Modes</b> Sets the node address if a CC-Link option card is installed.	Default: 0 Min: 0 Max: 64	–
F6-11 (3B7H)	CC-Link Communication Speed	<b>All Modes</b> 0: 156 Kbps 1: 625 Kbps 2: 2.5 Mbps 3: 5 Mbps 4: 10 Mbps	Default: 0 Min: 0 Max: 4	–
F6-14 (3BBH)	CC-Link bUS Error Auto Reset	<b>All Modes</b> 0: Disabled 1: Enabled	Default: 0 Min: 0 Max: 1	–
F6-20 (36BH)	MECHATROLINK Station Address	<b>All Modes</b> Sets the station address when the MECHATROLINK-II option has been installed.	Default: 21 Min: 20 Max: 3FH	–
F6-21 (36CH)	MECHATROLINK Frame Size	<b>All Modes</b> 0: 32 byte 1: 17 byte	Default: 0 Min: 0 Max: 1	–
F6-22 (36DH)	MECHATROLINK Link Speed	<b>All Modes</b> 0: 10 Mbps 1: 4 Mbps	Default: 0 Min: 0 Max: 1	–
F6-23 (36EH)	MECHATROLINK Monitor Selection (E)	<b>All Modes</b> Sets the MECHATROLINK-II monitor (E).	Default: 0 Min: 0 Max: FFFFH	–
F6-24 (36FH)	MECHATROLINK Monitor Selection (F)	<b>All Modes</b> Sets the MECHATROLINK-II monitor (F).	Default: 0 Min: 0 Max: FFFFH	–
F6-25 (3C9H)	Operation Selection at Watchdog Timer Error (E5)	<b>All Modes</b> 0: Ramp to stop. Decelerate to stop using the deceleration time in C1-02. 1: Coast to stop. 2: Fast Stop. Decelerate to stop using the deceleration time in C1-09. 3: Alarm only.	Default: 1 Min: 0 Max: 3	–
F6-26 (3CAH)	MECHATROLINK bUS Errors Detected	<b>All Modes</b> Sets the number of option communication errors (bUS).	Default: 2 Min: 2 Max: 10	–

## B.3 Parameter Table

No.(Addr.)	Name	Description	Setting	Page
F6-30 (3CBH)	PROFIBUS-DP Node Address	<b>All Modes</b> Sets the node address.	Default: 0 Min: 0 Max: 125	-
F6-31 (3CCH)	PROFIBUS-DP Clear Mode Selection	<b>All Modes</b> 0: Resets drive operation with a Clear mode command. 1: Maintains the previous operation state when Clear mode command is given.	Default: 0 Min: 0 Max: 1	-
F6-32 (3CDH)	PROFIBUS-DP Data Format Selection	<b>All Modes</b> 0: PPO Type 1: Conventional	Default: 0 Min: 0 Max: 1	-
F6-35 (3D0H)	CANopen Node ID Selection	<b>All Modes</b> Sets the node address.	Default: 0 Min: 0 Max: 126	-
F6-36 (3D1H)	CANopen Communication Speed	<b>All Modes</b> 0: Auto-detection 1: 10 kbps 2: 20 kbps 3: 50 kbps 4: 125 kbps 5: 250 kbps 6: 500 kbps 7: 800 kbps 8: 1 Mbps	Default: 6 Min: 0 Max: 8	-
F6-50 (3C1H)	DeviceNet MAC Address	<b>All Modes</b> Selects the drives MAC address.	Default: 0 Min: 0 Max: 64	-
F6-51 (3C2H)	DeviceNet Communication Speed	<b>All Modes</b> 0: 125 kbps 1: 250 kbps 2: 500 kbps 3: Adjustable from network 4: Detect automatically	Default: 0 Min: 0 Max: 4	-
F6-52 (3C3H)	DeviceNet PCA Setting	<b>All Modes</b> Sets the format of the data set from the DeviceNet master to the drive.	Default: 21 Min: 0 Max: 255	-
F6-53 (3C4H)	DeviceNet PPA Setting	<b>All Modes</b> Sets the format of the data set from the drive to the DeviceNet master.	Default: 71 Min: 0 Max: 255	-
F6-54 (3C5H)	DeviceNet Idle Mode Fault Detection	<b>All Modes</b> 0: Enabled 1: Disabled, no fault detection	Default: 0 Min: 0 Max: 1	-
F6-55 (3C6H)	DeviceNet Baud Rate Monitor	<b>All Modes</b> Used to verify the baud rate running on the network. 0: 125 kbps 1: 250 kbps 2: 500 kbps	Default: 0 Min: 0 Max: 2	-
F6-56 (3D7H)	DeviceNet Speed Scaling	<b>All Modes</b> Sets the scaling factor for the speed monitor in DeviceNet.	Default: 0 Min: -15 Max: 15	-
F6-57 (3D8H)	DeviceNet Current Scaling	<b>All Modes</b> Sets the scaling factor for the output current monitor in DeviceNet.	Default: 0 Min: -15 Max: 15	-
F6-58 (3D9H)	DeviceNet Torque Scaling	<b>All Modes</b> Sets the scaling factor for the torque monitor in DeviceNet.	Default: 0 Min: -15 Max: 15	-
F6-59 (3DAH)	DeviceNet Power Scaling	<b>All Modes</b> Sets the scaling factor for the power monitor in DeviceNet.	Default: 0 Min: -15 Max: 15	-
F6-60 (3DBH)	DeviceNet Voltage Scaling	<b>All Modes</b> Sets the scaling factor for the voltage monitor in DeviceNet.	Default: 0 Min: -15 Max: 15	-
F6-61 (3DCH)	DeviceNet Time Scaling	<b>All Modes</b> Sets the scaling factor for the time monitor in DeviceNet.	Default: 0 Min: -15 Max: 15	-
F6-62 (3DDH)	DeviceNet Heartbeat Interval	<b>All Modes</b> Sets the heartbeat interval for DeviceNet communications.	Default: 0 Min: 0 Max: 10	-
F6-63 (3DEH)	DeviceNet Network MAC ID	<b>All Modes</b> Used to verify the MAC ID the drive has been assigned.	Default: 0 Min: 0 Max: 63	-
F6-64 to F6-71 (3DFH to 3C8H)	Reserved	<b>All Modes</b> Reserved for Dynamic I/O Assembly Parameters.	-	-

<3> Parameter setting value is not reset to the default value when the drive is initialized.

## ◆ H Parameters: Multi-Function Terminals

H parameters assign functions to the multi-function input and output terminals.

### ■ H1: Multi-Function Digital Inputs

No.(Addr.)	Name	Description	Setting	Page
H1-01 (438H)	Multi-Function Digital Input Terminal S1 Function Selection	<p><b>All Modes</b></p> <p>Assigns a function to the multi-function digital inputs. Refer to <a href="#">H1 Multi-Function Digital Input Selections on page 373</a> for a description of setting values. <b>Note:</b> Unused terminals should be set to F.</p>	Default: 40 (F) <31> Min: 1 Max: 9F	181
H1-02 (439H)	Multi-Function Digital Input Terminal S2 Function Selection		Default: 41 (F) <31> Min: 1 Max: 9F	181
H1-03 (400H)	Multi-Function Digital Input Terminal S3 Function Selection		Default: 24 Min: 0 Max: 9F	181
H1-04 (401H)	Multi-Function Digital Input Terminal S4 Function Selection		Default: 14 Min: 0 Max: 9F	181
H1-05 (402H)	Multi-Function Digital Input Terminal S5 Function Selection		Default: 3(0) <31> Min: 0 Max: 9F	181
H1-06 (403H)	Multi-Function Digital Input Terminal S6 Function Selection		Default: 4(3) <31> Min: 0 Max: 9F	181
H1-07 (404H)	Multi-Function Digital Input Terminal S7 Function Selection		Default: 6(4) <31> Min: 0 Max: 9F	181
H1-08 (405H)	Multi-Function Digital Input Terminal S8 Function Selection		Default: 8 Min: 0 Max: 9F	181

<31> Value in parenthesis is the default setting when a 3-wire initialization is performed (A1-03 = 3330).

H1 Multi-Function Digital Input Selections			
H1-□□ Setting	Function	Description	Page
0	3-wire Sequence	<p><b>All Modes</b></p> <p>Closed: Reverse rotation (only if the drive is set up for 3-wire sequence) Terminals S1 and S2 are automatically set up for the Run command and Stop command.</p>	182
1	LOCAL/REMOTE Selection	<p><b>All Modes</b></p> <p>Open: REMOTE (parameter settings determine the source of the frequency Reference 1 or 2 (b1-01, b1-02 or b1-15, b1-16) Closed: LOCAL, digital operator is run and reference source</p>	182
2	External Reference 1/2 Selection	<p><b>All Modes</b></p> <p>Open: Run command and frequency reference source 1 (determined by b1-01 and b1-02) Closed: Run command and frequency reference source 2 (determined by b1-15 and b1-16)</p>	183
3	Multi-Step Speed Reference 1	<p><b>All Modes</b></p> <p>When input terminals are set to Multi-Step Speed References 1 through 3, switching combinations of those terminals will create a multi-step speed sequence using the frequency references set in d1-01 through d1-08.</p>	183
4	Multi-Step Speed Reference 2		183
6	Jog Reference Selection	<p><b>All Modes</b></p> <p>Closed: Jog frequency reference (d1-17) selected. Jog has priority over all other reference sources.</p>	183
7	Accel/Decel Time Selection 1	<p><b>All Modes</b></p> <p>Used to switch between accel/decel time 1 (set in C1-01, C1-02) and accel/decel time 2 (set in C1-03, C1-04).</p>	183
8	Baseblock Command (N.O.)	<p><b>All Modes</b></p> <p>Closed: No drive output</p>	183
9	Baseblock Command (N.C.)	<p><b>All Modes</b></p> <p>Open: No drive output</p>	183
A	Accel/Decel Ramp Hold	<p><b>All Modes</b></p> <p>Open: Accel/decel is not held Closed: The drive pauses during acceleration or deceleration and maintains the output frequency.</p>	183
B	Drive Overheat Alarm (oH2)	<p><b>All Modes</b></p> <p>Closed: Closes when an oH2 alarm occurs</p>	183
C	Analog Terminal Input Selection	<p><b>All Modes</b></p> <p>Open: Function assigned by H3-14 is disabled. Closed: Function assigned by H3-14 is enabled.</p>	184

## B.3 Parameter Table

H1 Multi-Function Digital Input Selections			
H1-□□ Setting	Function	Description	Page
F	Through Mode	<p><b>All Modes</b></p> <p>Select this setting when using the terminal in a pass-through mode. The terminal does not trigger a drive function but can be used as digital input for the controller the drive is connected to.</p>	184
10	Up Command	<p><b>All Modes</b></p> <p>The drive accelerates when the Up command terminal closes, and decelerates when the Down command closes. When both terminals are closed or both are open, the drive holds the frequency reference. The Up and Down commands must always be used in conjunction with one another.</p>	184
11	Down Command		184
12	Forward Jog	<p><b>All Modes</b></p> <p>Closed: Runs forward at the Jog frequency d1-17.</p>	185
13	Reverse Jog	<p><b>All Modes</b></p> <p>Closed: Runs reverse at the Jog frequency d1-17.</p>	185
14	Fault Reset	<p><b>All Modes</b></p> <p>Closed: Resets faults if the cause is cleared and the Run command is removed.</p>	185
15	Fast Stop (N.O.)	<p><b>All Modes</b></p> <p>Closed: Decelerates at the Fast Stop time set to C1-09.</p>	185
17	Fast Stop (N.C.)	<p><b>All Modes</b></p> <p>Open: Decelerates to stop at the Fast Stop time set to C1-09.</p>	185
18	Timer Function Input	<p><b>All Modes</b></p> <p>Triggers the timer set up by parameters b4-01 and b4-02. Must be set in conjunction with the timer function output (H2-□□ = 12).</p>	186
19	PI Disable	<p><b>All Modes</b></p> <p>Open: PI control enabled Closed: PI control disabled</p>	186
1B	Program Lockout	<p><b>All Modes</b></p> <p>Open: Parameters cannot be edited (except for U1-01 if the reference source is assigned to the digital operator). Closed: Parameters can be edited and saved.</p>	186
1E	Reference Sample Hold	<p><b>All Modes</b></p> <p>Closed: Samples the analog frequency reference and operates the drive at that speed.</p>	186
20 to 2F	External Fault	<p><b>All Modes</b></p> <p>20: N.O., Always detected, ramp to stop 21: N.C., Always detected, ramp to stop 22: N.O., During run, ramp to stop 23: N.C., During run, ramp to stop 24: N.O., Always detected, coast to stop 25: N.C., Always detected, coast to stop 26: N.O., During run, coast to stop 27: N.C., During run, coast to stop 28: N.O., Always detected, Fast Stop 29: N.C., Always detected, Fast Stop 2A: N.O., During run, Fast Stop 2B: N.C., During run, Fast Stop 2C: N.O., Always detected, alarm only (continue running) 2D: N.C., Always detected, alarm only (continue running) 2E: N.O., During run, alarm only (continue running) 2F: N.C., During run, alarm only (continue running)</p>	186
30	PI Integral Reset	<p><b>All Modes</b></p> <p>Closed: Resets the PI control integral value.</p>	187
31	PI Integral Hold	<p><b>All Modes</b></p> <p>Open: Performs integral operation. Closed: Maintains the current PI control integral value.</p>	187
34	PI Soft Starter Cancel	<p><b>All Modes</b></p> <p>Open: PI soft starter is enabled. Closed: Disables the PI soft starter b5-17.</p>	187
35	PI Input Level Selection	<p><b>All Modes</b></p> <p>Closed: Inverts the PI input signal</p>	187
36	External Reference 1/2 Selection 2	<p><b>All Modes</b></p> <p>Open: Run command and frequency reference source 2 (determined by b1-15 and b1-16) Closed: Run command and frequency reference source 1 (determined by b1-01 and b1-02)</p>	187

H1 Multi-Function Digital Input Selections			
H1-□□ Setting	Function	Description	Page
40	Forward Run Command (2-wire Sequence)	<b>All Modes</b> Open: Stop Closed: Forward run <b>Note:</b> Cannot be set together with settings 42 or 43.	187
41	Reverse Run Command (2-wire Sequence)	<b>All Modes</b> Open: Stop Closed: Reverse run <b>Note:</b> Cannot be set together with settings 42 or 43.	187
42	Run Command (2-wire Sequence 2)	<b>All Modes</b> Open: Stop Closed: Run <b>Note:</b> Cannot be set together with settings 40 or 41.	188
43	FWD/REV Command (2-wire Sequence 2)	<b>All Modes</b> Open: Forward Closed: Reverse <b>Note:</b> Determines motor direction, but does not issue a Run command. Cannot be set together with settings 40 or 41.	188
44	Offset Frequency 1	<b>All Modes</b> Closed: Adds d7-01 to the frequency reference.	188
45	Offset Frequency 2	<b>All Modes</b> Closed: Adds d7-02 to the frequency reference.	188
46	Offset Frequency 3	<b>All Modes</b> Closed: Adds d7-03 to the frequency reference.	188
47	Node Setup	<b>All Modes</b> Closed: Node setup for SI-S3 enabled.	188
50	Motor Pre-Heat 2	<b>V/f</b> <b>OLV/PM</b> Closed: Triggers Motor Pre-Heat 2.	188
60	Motor Pre-Heat 1	<b>V/f</b> <b>OLV/PM</b> Closed: Triggers Motor Pre-Heat 1.	188
61	External Speed Search Command 1	<b>All Modes</b> Closed: Activates Current Detection Speed Search from the maximum output frequency (E1-04).	188
62	External Speed Search Command 2	<b>All Modes</b> Closed: Activates Current Detection Speed Search from the frequency reference.	188
63	Field Weakening	<b>V/f</b> <b>OLV/PM</b> Closed: The drive performs Field Weakening control as set for d6-01 and d6-02.	189
65	KEB Ride-Thru 1 (N.C.)	<b>All Modes</b> Open: KEB Ride-Thru 1 enabled	189
66	KEB Ride-Thru 1 (N.O.)	<b>All Modes</b> Closed: KEB Ride-Thru 1 enabled	189
67	Communications Test Mode	<b>All Modes</b> Tests the MEMOBUS/Modbus RS-485/422 interface. Displays "PASS" if the test completes successfully.	189
68	High Slip Braking	<b>V/f</b> <b>OLV/PM</b> Closed: Activates High Slip Braking to stop the drive.	189
69	Jog 2	<b>All Modes</b> Cause the drive to ramp to the Jog Frequency Reference (d1-17).	189
6A	Drive Enable	<b>All Modes</b> Open: Drive disabled. If this input is opened during run, then the drive will stop as specified by b1-03. Closed: Ready for operation.	189
7A	KEB Ride-Thru 2 (N.C.)	<b>All Modes</b> Open: KEB Ride-Thru 2 enabled. Drive disregards L2-29 and performs Single Drive KEB Ride-Thru 2.	189
7B	KEB Ride-Thru 2 (N.O.)	<b>All Modes</b> Closed: KEB Ride-Thru 2 enabled. Drive disregards L2-29 and performs Single Drive KEB Ride-Thru 2.	189
7C	Short Circuit Braking (N.O.)	<b>V/f</b> <b>OLV/PM</b> Closed: Short Circuit Braking enabled	189
7D	Short Circuit Braking (N.C.)	<b>V/f</b> <b>OLV/PM</b> Open: Short Circuit Braking enabled	189

## B.3 Parameter Table

H1 Multi-Function Digital Input Selections			
H1-□□ Setting	Function	Description	Page
90 to 97	DriveWorksEZ Digital Inputs 1 to 8	<b>All Modes</b> Reserved for DWEZ input functions	190
9F	DriveWorksEZ Disable	<b>All Modes</b> Open: DWEZ enabled Closed: DWEZ disabled	190

## ■ H2: Multi-Function Digital Outputs

No.(Addr.)	Name	Description	Setting	Page
H2-01 (40BH)	Terminals M1-M2 Function Selection (relays)	<b>All Modes</b> Refer to H2 Multi-Function Digital Output Settings on page 376 for a description of setting values.	Default: 0 Min: 0 Max: 192	190
H2-02 (40CH)	Terminals M3-M4 Function Selection (relays)		Default: 1 Min: 0 Max: 192	190
H2-03 (40DH)	Terminals M5-M6 Function Selection (relays)		Default: 2 Min: 0 Max: 192	190
H2-06 (437H)	Watt Hour Output Unit Selection	<b>All Modes</b> Outputs a 200 ms pulse signal when the watt-hour counter increases by the units selected. 0: 0.1 kWh units 1: 1 kWh units 2: 10 kWh units 3: 100 kWh units 4: 1000 kWh units	Default: 0 Min: 0 Max: 4	198

H2 Multi-Function Digital Output Settings			
H2-□□ Setting	Function	Description	Page
0	During Run	<b>All Modes</b> Closed: A Run command is active or voltage is output.	190
1	Zero Speed	<b>All Modes</b> Open: Output frequency is above the minimum output frequency set in E1-09. Closed: Output frequency is below the minimum output frequency set in E1-09.	191
2	Speed Agree 1	<b>All Modes</b> Closed: Output frequency equals the speed reference (plus or minus the hysteresis set to L4-02).	191
3	User-set Speed Agree 1	<b>All Modes</b> Closed: Output frequency and speed reference equal L4-01 (plus or minus the hysteresis set to L4-02).	191
4	Frequency Detection 1	<b>All Modes</b> Closed: Output frequency is less than or equal to the value in L4-01 with hysteresis determined by L4-02.	192
5	Frequency Detection 2	<b>All Modes</b> Closed: Output frequency is greater than or equal to the value in L4-01 with hysteresis determined by L4-02.	192
6	Drive Ready	<b>All Modes</b> Closed: Power up is complete and the drive is ready to accept a Run command.	193
7	DC bus Undervoltage	<b>All Modes</b> Closed: DC bus voltage is below the Uv trip level set in L2-05.	193
8	During Baseblock (N.O.)	<b>All Modes</b> Closed: Drive has entered the baseblock state (no output voltage).	193
9	Frequency Reference Source	<b>All Modes</b> Open: External Reference 1 or 2 supplies the frequency reference (set in b1-01 or b1-15). Closed: Digital operator supplies the frequency reference.	193
A	Run Command Source	<b>All Modes</b> Open: External Reference 1 or 2 supplies the Run command (set in b1-02 or b1-16). Closed: Digital operator supplies the Run command.	193
B	Torque Detection 1 (N.O.)	<b>All Modes</b> Closed: An overtorque or undertorque situation has been detected.	194
C	Frequency Reference Loss	<b>All Modes</b> Closed: Analog frequency reference has been lost.	194
E	Fault	<b>All Modes</b> Closed: Fault occurred.	194



H2 Multi-Function Digital Output Settings			
H2-□□ Setting	Function	Description	Page
F	Through Mode	<b>All Modes</b> Set this value when using the terminal in the pass-through mode.	194
10	Minor Fault	<b>All Modes</b> Closed: An alarm has been triggered, or the IGBTs have reached 90% of their expected life span.	194
11	Fault Reset Command Active	<b>All Modes</b> Closed: A command has been entered to clear a fault via the input terminals or from the serial network.	194
12	Timer Output	<b>All Modes</b> Closed: Timer output.	194
13	Speed Agree 2	<b>All Modes</b> Closed: When drive output frequency equals the frequency reference $\pm$ L4-04.	194
14	User-set Speed Agree 2	<b>All Modes</b> Closed: When the drive output frequency is equal to the value in L4-03 $\pm$ L4-04.	195
15	Frequency Detection 3	<b>All Modes</b> Closed: When the drive output frequency is less than or equal to the value in L4-03 $\pm$ L4-04.	195
16	Frequency Detection 4	<b>All Modes</b> Closed: When the output frequency is greater than or equal to the value in L4-03 $\pm$ L4-04.	195
17	Torque Detection 1 (N.C.)	<b>All Modes</b> Open: Overtorque or undertorque has been detected.	194
18	Torque Detection 2 (N.O.)	<b>All Modes</b> Closed: Overtorque or undertorque has been detected.	194
19	Torque Detection 2 (N.C.)	<b>All Modes</b> Open: Overtorque or undertorque has been detected.	194
1B	During Baseblock (N.C.)	<b>All Modes</b> Open: Drive has entered the baseblock state (no output voltage).	196
1F	Motor Overload Alarm (oL1)	<b>All Modes</b> Closed: oL1 is at 90% of its trip point or greater. An oH3 situation also triggers this alarm.	196
20	Drive Overheat Pre-alarm (oH)	<b>All Modes</b> Closed: Heatsink temperature exceeds the parameter L8-02 value.	196
2F	Maintenance Period	<b>All Modes</b> Closed: Cooling fan, electrolytic capacitors, IGBTs, or the soft charge bypass relay may require maintenance.	197
37	During Frequency Output	<b>All Modes</b> Open: Either the drive has stopped or baseblock, DC Injection Braking, or Initial Excitation is being performed. Closed: Drive is running the motor (not in a baseblock state and DC Injection is not being performed).	197
38	Drive Enable	<b>All Modes</b> Closed: Multi-function input set for "Drive enable" is closed (H1-□□ = 6A)	197
39	Watt Hour Pulse Output	<b>All Modes</b> Output units are determined by H2-06. Outputs a pulse every 200 ms to indicate the kWh count.	197
3A	Drive Overheat Alarm (oH2)	<b>All Modes</b> Closed: An external device triggered an overheat warning in the drive.	197
3B	RUN Command from Option Card/ Communications	<b>All Modes</b> Open: Run command is not input from the MEMOBUS/Modbus communication or a Communication option. Closed: Run command is input from the MEMOBUS/Modbus communication or a Communication option.	197
3C	LOCAL/REMOTE Status	<b>All Modes</b> Open: REMOTE Closed: LOCAL	197
3D	During Speed Search	<b>All Modes</b> Closed: Speed Search is being executed.	197
3E	PI Feedback Low	<b>All Modes</b> Closed: PI feedback level is too low.	197
3F	PI Feedback High	<b>All Modes</b> Closed: The PI feedback level is too high.	198
4A	During KEB Operation	<b>All Modes</b> Closed: KEB Ride-Thru is being performed.	198

## B.3 Parameter Table

H2 Multi-Function Digital Output Settings				
H2-□□ Setting	Function	Description		Page
4B	During Short Circuit Braking		Closed: Short Circuit Braking is active.	198
4C	During Fast Stop		Closed: A Fast Stop command has been entered from the operator or input terminals.	198
4D	oH Pre-alarm Time Limit		Closed: oH pre-alarm time limit has passed.	198
50	Waiting for Run		Closed: Delay executing any run command until the time set in b1-11 has expired.	198
58	Underload Detection		Closed: Underload is detected.	198
60	Internal Cooling Fan Alarm		Closed: Internal cooling fan alarm	198
90 to 92	DriveWorksEZ Digital Outputs 1 to 3		Reserved for DWEZ digital output functions.	198
100 to 192	Function 0 to 92 with Inverse Output		Inverts the output switching of the multi-function output functions. Set the last two digits of 1□□ to reverse the output signal of that specific function.	198

## ■ H3: Multi-Function Analog Inputs

No.(Addr.)	Name	Description	Setting	Page
H3-01 (410H)	Terminal A1 Signal Level Selection	 0: 0 to 10 Vdc 1: -10 to 10 Vdc	Default: 0 Min: 0 Max: 1	199
H3-02 (434H)	Terminal A1 Function Selection	 Sets the function of terminal A1.	Default: 0 Min: 0 Max: 32	199
H3-03 (411H) 	Terminal A1 Gain Setting	 Sets the level of the input value selected in H3-02 when 10 V is input at terminal A1.	Default: 100.0% Min: -999.9% Max: 999.9%	199
H3-04 (412H) 	Terminal A1 Bias Setting	 Sets the level of the input value selected in H3-02 when 0 V is input at terminal A1.	Default: 0.0% Min: -999.9% Max: 999.9%	199
H3-05 (413H)	Terminal A3 Signal Level Selection	 0: 0 to 10 Vdc 1: -10 to 10 Vdc	Default: 0 Min: 0 Max: 1	200
H3-06 (414H)	Terminal A3 Function Selection	 Sets the function of terminal A3.	Default: 2 Min: 0 Max: 31	200
H3-07 (415H) 	Terminal A3 Gain Setting	 Sets the level of the input value selected in H3-06 when 10 V is input at terminal A3.	Default: 100.0% Min: -999.9% Max: 999.9%	201
H3-08 (416H) 	Terminal A3 Bias Setting	 Sets the level of the input value selected in H3-06 when 0 V is input at terminal A3.	Default: 0.0% Min: -999.9% Max: 999.9%	201
H3-09 (417H)	Terminal A2 Signal Level Selection	 0: 0 to 10 Vdc 1: -10 to 10 Vdc 2: 4 to 20 mA Current Input 3: 0 to 20 mA Current Input <b>Note:</b> Use DIP switch S1 to set input terminal A2 for a current or a voltage input signal.	Default: 2 Min: 0 Max: 3	201
H3-10 (418H)	Terminal A2 Function Selection	 Sets the function of terminal A2.	Default: 0 Min: 0 Max: 31	201
H3-11 (419H) 	Terminal A2 Gain Setting	 Sets the level of the input value selected in H3-10 when 10 V (20 mA) is input at terminal A2.	Default: 100.0% Min: -999.9% Max: 999.9%	201
H3-12 (41AH) 	Terminal A2 Bias Setting	 Sets the level of the input value selected in H3-10 when 0 V (0 or 4 mA) is input at terminal A2.	Default: 0.0% Min: -999.9% Max: 999.9%	201





No.(Addr.)	Name	Description	Setting	Page
H3-13 (41BH)	Analog Input Filter Time Constant	<b>All Modes</b> Sets a primary delay filter time constant for terminals A1, A2, and A3. Used for noise filtering.	Default: 0.03 s Min: 0.00 s Max: 2.00 s	201
H3-14 (41CH)	Analog Input Terminal Enable Selection	<b>All Modes</b> Determines which of the analog input terminals will be enabled when a digital input programmed for "Analog input enable" (H1-□□ = C) is activated. 1: A1 only enable 2: A2 only enable 3: A1 and A2 only enable 4: A3 only enable 5: A1 and A3 enable 6: A2 and A3 enable 7: All analog input terminals enabled	Default: 7 Min: 1 Max: 7	202
H3-16 (2F0H)	Terminal A1 Offset	<b>All Modes</b> Adds an offset when the analog signal to terminal A1 is at 0 V.	Default: 0 Min: -500 Max: 500	202
H3-17 (2F1H)	Terminal A2 Offset	<b>All Modes</b> Adds an offset when the analog signal to terminal A2 is at 0 V.	Default: 0 Min: -500 Max: 500	202
H3-18 (2F2H)	Terminal A3 Offset	<b>All Modes</b> Adds an offset when the analog signal to terminal A3 is at 0 V.	Default: 0 Min: -500 Max: 500	202

H3 Multi-Function Analog Input Settings				
H3-□□ Setting	Function	Description		Page
0	Frequency Bias	<b>All Modes</b> 10 V = E1-04 (maximum output frequency)		202
1	Frequency Gain	<b>All Modes</b> 0 to 10 V signal allows a setting of 0 to 100%. -10 to 0 V signal allows a setting of -100 to 0%.		203
2	Auxiliary Frequency Reference 1 (used as a Multi-Step Speed 2)	<b>All Modes</b> 10 V = E1-04 (maximum output frequency)		203
3	Auxiliary Frequency Reference 2 (3rd step analog)	<b>All Modes</b> 10 V = E1-04 (maximum output frequency)		203
4	Output Voltage Bias	<b>V/f</b> <b>OLV/PM</b> 10 V = E1-05 (motor rated voltage)		203
5	Accel/Decel Time Gain	<b>All Modes</b> 10V=100% Accel/Decel Gain		203
6	DC Injection Braking Current	<b>V/f</b> <b>OLV/PM</b> 10 V = Drive rated current		203
7	Torque Detection Level	<b>All Modes</b> 10 V = Drive rated current (V/f) 10 V = Motor rated torque (OLV/PM)		203
8	Stall Prevention Level During Run	<b>V/f</b> <b>OLV/PM</b> 10 V = Drive rated current		204
9	Output Frequency Lower Limit Level	<b>All Modes</b> 10 V = E1-04 (maximum output frequency)		204
B	PI Feedback	<b>All Modes</b> 10V=100% Feed back		204
C	PI Setpoint	<b>All Modes</b> 10V=100% PI setpoint		204
D	Frequency Bias	<b>All Modes</b> 10 V = E1-04 (maximum output frequency)		204
E	Motor Temperature (PTC input)	<b>All Modes</b> 10 V = 100%		204
F	Through Mode	<b>All Modes</b> Set this value when using the terminal in the pass-through mode.		204
16	Differential PI Feedback	<b>All Modes</b> 10 V = 100%		204

## B.3 Parameter Table

H3 Multi-Function Analog Input Settings				
H3-□□ Setting	Function	Description	Page	
17	Motor Thermistor (NTC)	<p><b>All Modes</b></p> <p>10 V = -9°C 0 V = 234°C</p> <p><b>Note:</b> This function is available in models CIMR-E□4A0930 and 4A1200.</p>	204	
1F	Through Mode	<p><b>All Modes</b></p> <p>Set this value when using the terminal in the pass-through mode.</p>	204	
30 to 32	DriveWorksEZ Analog Input 1 to 3	<p><b>All Modes</b></p> <p>Output is determined by the function selected using DWEZ.</p>	204	

### ■ H4: Analog Outputs

No.(Addr.)	Name	Description	Setting	Page
H4-01 (41DH)	Multi-Function Analog Output Terminal FM Monitor Selection	<p><b>All Modes</b></p> <p>Selects the data to be output through multi-function analog output terminal FM. Set the desired monitor parameter to the digits available in U□-□□. For example, enter "103" for U1-03.</p>	Default: 102 Min: 000 Max: 999	205
H4-02 (41EH) 	Multi-Function Analog Output Terminal FM Gain	<p><b>All Modes</b></p> <p>Sets the signal level at terminal FM that is equal to 100% of the selected monitor value.</p>	Default: 100.0% Min: -999.9% Max: 999.9%	205
H4-03 (41FH) 	Multi-Function Analog Output Terminal FM Bias	<p><b>All Modes</b></p> <p>Sets the bias value added to the terminal FM output signal.</p>	Default: 0.0% Min: -999.9% Max: 999.9%	205
H4-04 (420H)	Multi-Function Analog Output Terminal AM Monitor Selection	<p><b>All Modes</b></p> <p>Selects the data to be output through multi-function analog output terminal AM. Set the desired monitor parameter to the digits available in U□-□□. For example, enter "103" for U1-03.</p>	Default: 103 Min: 000 Max: 999	205
H4-05 (421H) 	Multi-Function Analog Output Terminal AM Gain	<p><b>All Modes</b></p> <p>Sets the signal level at terminal AM that is equal to 100% of the selected monitor value.</p>	Default: 50.0% Min: -999.9% Max: 999.9%	205
H4-06 (422H) 	Multi-Function Analog Output Terminal AM Bias	<p><b>All Modes</b></p> <p>Sets the bias value added to the terminal AM output signal.</p>	Default: 0.0% Min: -999.9% Max: 999.9%	205
H4-07 (423H)	Multi-Function Analog Output Terminal FM Signal Level Selection	<p><b>All Modes</b></p> <p>0: 0 to 10 V 1: -10 to 10 V 2: 4 to 20 mA</p>	Default: 0 Min: 0 Max: 1	206
H4-08 (424H)	Multi-Function Analog Output Terminal AM Signal Level Selection	<p><b>All Modes</b></p> <p>0: 0 to 10 V 1: -10 to 10 V 2: 4 to 20 mA</p>	Default: 0 Min: 0 Max: 1	206

### ■ H5: MEMOBUS/Modbus Serial Communication

No.(Addr.)	Name	Description	Setting	Page
H5-01 (425H) <32>	Drive Node Address	<p><b>All Modes</b></p> <p>Selects drive station node number (address) for MEMOBUS/Modbus terminals R+, R-, S+, S-. Cycle power for the setting to take effect.</p>	Default: 1F Min: 0 Max: FFH	416
H5-02 (426H)	Communication Speed Selection	<p><b>All Modes</b></p> <p>0: 1200 bps 1: 2400 bps 2: 4800 bps 3: 9600 bps 4: 19200 bps 5: 38400 bps 6: 57600 bps 7: 76800 bps 8: 115200 bps</p> <p>Cycle power for the setting to take effect.</p>	Default: 3 Min: 0 Max: 8	416
H5-03 (427H)	Communication Parity Selection	<p><b>All Modes</b></p> <p>0: No parity 1: Even parity 2: Odd parity</p> <p>Cycle power for the setting to take effect.</p>	Default: 0 Min: 0 Max: 2	416

No.(Addr.)	Name	Description	Setting	Page
H5-04 (428H)	Stopping Method After Communication Error (CE)	<b>All Modes</b> 0: Ramp to stop 1: Coast to stop 2: Fast Stop 3: Alarm only	Default: 0 Min: 0 Max: 3	416
H5-05 (429H)	Communication Fault Detection Selection	<b>All Modes</b> 0: Disabled 1: Enabled. If communication is lost for more than two seconds, a CE fault will occur.	Default: 0 Min: 0 Max: 1	417
H5-06 (42AH)	Drive Transmit Wait Time	<b>All Modes</b> Set the wait time between receiving and sending data.	Default: 5 ms Min: 5 ms Max: 65 ms	417
H5-07 (42BH)	RTS Control Selection	<b>All Modes</b> 0: Disabled. RTS is always on. 1: Enabled. RTS turns on only when sending.	Default: 1 Min: 0 Max: 1	417
H5-09 (435H)	CE Detection Time	<b>All Modes</b> Sets the time required to detect a communications error. Adjustment may be needed when networking several drives.	Default: 2.0 s Min: 0.0 s Max: 10.0 s	417
H5-10 (436H)	Unit Selection for MEMOBUS/Modbus Register 0025H	<b>All Modes</b> 0: 0.1 V units 1: 1 V units	Default: 0 Min: 0 Max: 1	417
H5-11 (43CH)	Communications ENTER Function Selection	<b>All Modes</b> 0: Drive requires an Enter command before accepting any changes to parameter settings. 1: Parameter changes are activated immediately without the Enter command (same as V7).	Default: 0 Min: 0 Max: 1	418
H5-12 (43DH)	Run Command Method Selection	<b>All Modes</b> 0: FWD/Stop, REV/Stop 1: Run/Stop, FWD/REV	Default: 0 Min: 0 Max: 1	418

<32> If this parameter is set to 0, the drive will be unable to respond to MEMOBUS/Modbus commands.

## ■ H6: Pulse Train Input/Output

No.(Addr.)	Name	Description	Setting	Page
H6-01 (42CH)	Pulse Train Input Terminal RP Function Selection	<b>All Modes</b> 0: Frequency reference 1: PI feedback value 2: PI setpoint value	Default: 0 Min: 0 Max: 2	207
H6-02 (42DH) ◇ RUN	Pulse Train Input Scaling	<b>All Modes</b> Sets the terminal RP input signal frequency that is equal to 100% of the value selected in H6-01.	Default: 1440 Hz Min: 1000 Hz Max: 32000 Hz	207
H6-03 (42EH) ◇ RUN	Pulse Train Input Gain	<b>All Modes</b> Sets the level of the value selected in H6-01 when a frequency with the value set in H6-02 is input.	Default: 100.0% Min: 0.0% Max: 1000.0%	207
H6-04 (42FH) ◇ RUN	Pulse Train Input Bias	<b>All Modes</b> Sets the level of the value selected in H6-01 when 0 Hz is input.	Default: 0.0% Min: -100.0% Max: 100.0%	207
H6-05 (430H) ◇ RUN	Pulse Train Input Filter Time	<b>All Modes</b> Sets the pulse train input filter time constant.	Default: 0.10 s Min: 0.00 s Max: 2.00 s	207
H6-06 (431H) ◇ RUN	Pulse Train Monitor Selection	<b>All Modes</b> Select the pulse train monitor output function (value of the □-□□ part of U□-□□). Example: To select U5-01, set "501".	Default: 102 Min: 000 Max: 809	207
H6-07 (432H) ◇ RUN	Pulse Train Monitor Scaling	<b>All Modes</b> Sets the terminal MP output signal frequency when the monitor value is 100%. To have the pulse train monitor output equal the output frequency, set H6-06 to 102 and H6-07 to 0.	Default: 1440 Hz Min: 0 Hz Max: 32000 Hz	208
H6-08 (43FH)	Pulse Train Input Minimum Frequency	<b>All Modes</b> Sets the minimum frequency for the pulse train input to be detected. Enabled when H6-01 = 0, 1, or 2.	Default: 0.5 Hz Min: 0.1 Hz Max: 1000.0 Hz	208

## B.3 Parameter Table

### ◆ L: Protection Function

L parameters provide protection to the drive and motor, such as: control during momentary power loss, Stall Prevention, frequency detection, fault restarts, overtorque detection, and other types of hardware protection.

#### ■ L1: Motor Protection

No. (Addr.)	Name	Description	Setting	Page
L1-01 (480H)	Motor Overload Protection Selection	<p><b>All Modes</b></p> <p>0: Disabled 1: Standard Fan Cooled 4: PM motor with variable torque</p> <p>The drive may not be able to provide protection when multiple motors are used, even if overload is enabled in L1-01. Set L1-01 to 0 and install separate thermal relay to each motor.</p>	Default: <10> Min: 0 Max: 4	209
L1-02 (481H)	Motor Overload Protection Time	<p><b>All Modes</b></p> <p>Sets the motor thermal overload protection (oL1) time.</p>	Default: 1.0 min Min: 0.1 min Max: 5.0 min	210
L1-03 (482H)	Motor Overheat Alarm Operation Selection (PTC input)	<p><b>All Modes</b></p> <p>Sets operation when the motor temperature analog input (H3-02, H3-06, or H3-10 = E) exceeds the oH3 alarm level.</p> <p>0: Ramp to stop 1: Coast to stop 2: Fast Stop (decelerate to stop using the deceleration time in C1-09) 3: Alarm only ("oH3" will flash)</p>	Default: 3 Min: 0 Max: 3	212
L1-04 (483H)	Motor Overheat Fault Operation Selection (PTC input)	<p><b>All Modes</b></p> <p>Sets stopping method when the motor temperature analog input (H3-02, H3-06, or H3-10 = E) exceeds the oH4 fault level.</p> <p>0: Ramp to stop 1: Coast to stop 2: Fast Stop (decelerate to stop using the deceleration time in C1-09)</p>	Default: 1 Min: 0 Max: 2	212
L1-05 (484H)	Motor Temperature Input Filter Time (PTC input)	<p><b>All Modes</b></p> <p>Adjusts the filter for the motor temperature analog input (H3-02, H3-06, or H3-10 = E).</p>	Default: 0.20 s Min: 0.00 s Max: 10.00 s	212
L1-13 (46DH)	Continuous Electrothermal Operation Selection	<p><b>All Modes</b></p> <p>0: Disabled 1: Enabled</p>	Default: 1 Min: 0 Max: 1	212
L1-15 (440H)	Motor 1 Thermistor Selection (NTC)	<p><b>All Modes</b></p> <p>0: Disabled 1: Enabled</p> <p><b>Note:</b> This parameter is available in models CIMR-E□4A0930 and 4A1200.</p>	Default: 0 Min: 0 Max: 1	213
L1-16 (441H)	Motor 1 Overheat Temperature	<p><b>All Modes</b></p> <p>Sets the temperature for motor 1 that triggers an overheat fault (oH5).</p> <p><b>Note:</b> This parameter is available in models CIMR-E□4A0930 and 4A1200.</p>	Default: 120 Min: 50 Max: 200	213
L1-19 (444H)	Operation at Thermistor Disconnect (THo) (NTC)	<p><b>All Modes</b></p> <p>Determines what action the drive should take when a thermistor disconnect fault occurs (Tho).</p> <p>0: Ramp to stop 1: Coast to stop 2: Fast Stop (decelerate to stop using the deceleration time in C1-09) 3: Alarm only ("THo" will flash)</p> <p><b>Note:</b> This parameter is available in models CIMR-E□4A0930 and 4A1200.</p>	Default: 3 Min: 0 Max: 3	214
L1-20 (445H)	Operation at Motor Overheat (oH5)	<p><b>All Modes</b></p> <p>Determines what action the drive should take when a motor overheat fault occurs (oH5).</p> <p>0: Ramp to stop 1: Coast to stop 2: Fast Stop (decelerate to stop using the deceleration time in C1-09) 3: Alarm only ("oH5" will flash)</p> <p><b>Note:</b> This parameter is available in models CIMR-E□4A0930 and 4A1200.</p>	Default: 1 Min: 0 Max: 3	214

<10> Default setting is determined by the control mode (A1-02).

#### ■ L2: Momentary Power Loss Ride-Thru

No. (Addr.)	Name	Description	Setting	Page
L2-01 (485H)	Momentary Power Loss Operation Selection	<p><b>All Modes</b></p> <p>0: Disabled. Drive trips on (Uv1) fault when power is lost. 1: Recover within L2-02. Uv1 will be detected if power loss is longer than L2-02. 2: Recover as long as CPU has power. Uv1 is not detected. 3: KEB Ride-Thru operation within L2-02. 4: KEB Ride-Thru as long as CPU has power. 5: Ramp to Stop with KEB deceleration.</p>	Default: 0 Min: 0 Max: 5	214
L2-02 (486H)	Momentary Power Loss Ride-Thru Time	<p><b>All Modes</b></p> <p>Sets the Power Loss Ride-Thru time. Enabled only when L2-01 = 1 or 3.</p>	Default: <9> Min: 0.0 s Max: 25.5 s	219

No. (Addr.)	Name	Description	Setting	Page
L2-03 (487H)	Momentary Power Loss Minimum Baseblock Time	<b>All Modes</b> Sets the minimum wait time for residual motor voltage decay before the drive output reenergizes after performing Power Loss Ride-Thru. Increasing the time set to L2-03 may help if overcurrent or overvoltage occur during Speed Search or during DC Injection Braking.	Default: <9> Min: 0.1 s Max: 5.0 s	219
L2-04 (488H)	Momentary Power Loss Voltage Recovery Ramp Time	<b>V/f</b> <b>OLV/PM</b> Sets the time for the output voltage to return to the preset V/f pattern during Speed Search.	Default: <9> Min: 0.0 s Max: 5.0 s	219
L2-05 (489H)	Undervoltage Detection Level (Uv)	<b>All Modes</b> Sets the DC bus undervoltage trip level.	Default: <18> <33> Min: 150 Vdc Max: 210 Vdc <18>	219
L2-06 (48AH)	KEB Deceleration Time	<b>All Modes</b> Sets the time required to decelerate from the speed when KEB was activated to zero speed.	Default: 0.00 s Min: 0.00 s Max: 6000.0 s <12>	220
L2-07 (48BH)	KEB Acceleration Time	<b>All Modes</b> Sets the time to accelerate to the frequency reference when momentary power loss is over. If set to 0.0, the active acceleration time is used.	Default: 0.00 s Min: 0.00 s Max: 6000.0 s <12>	220
L2-08 (48CH)	Frequency Gain at KEB Start	<b>V/f</b> <b>OLV/PM</b> Sets the percentage of output frequency reduction at the beginning of deceleration when the KEB Ride-Thru function is started. Reduction = (slip frequency before KEB) × L2-08 × 2	Default: 100% Min: 0% Max: 300%	220
L2-10 (48EH)	KEB Detection Time (Minimum KEB Time)	<b>All Modes</b> Sets the time to perform KEB Ride-Thru.	Default: 50 ms Min: 0 ms Max: 2000 ms	220
L2-11 (461H)	DC Bus Voltage Setpoint during KEB	<b>All Modes</b> Sets the desired value of the DC bus voltage during KEB Ride-Thru.	Default: <18> <33> [E1-01] × 1.22 Min: 150 Vdc Max: 400 Vdc <18>	220
L2-29 (475H)	KEB Method Selection	<b>All Modes</b> 0: Single Drive KEB Ride-Thru 1 1: Single Drive KEB Ride-Thru 2	Default: 0 Min: 0 Max: 1	220

<9> Default setting is determined by the drive model (o2-04).

<12> Setting range value is dependent on the units selected for the accel/decel time (C1-10). When C1-10 = 0 (units of 0.01 s), the setting range becomes 0.00 to 600.00 s.

<18> Values shown here are for 200 V class drives. Double the value when using a 400 V class drive.

<33> Default setting value is dependent on the setting for the input voltage (E1-01).

### ■ L3: Stall Prevention

No. (Addr.)	Name	Description	Setting	Page
L3-01 (48FH)	Stall Prevention Selection during Acceleration	<b>All Modes</b> 0: Disabled. 1: Enable. 2: Intelligent Stall Prevention. <b>Note:</b> Setting 2 is not available when using OLV/PM.	Default: 1 Min: 0 Max: 2	221
L3-02 (490H)	Stall Prevention Level during Acceleration	<b>All Modes</b> Used when L3-01 = 1 or 2. 100% is equal to the drive rated current.	Default: <35> Min: 0% Max: 150% <35>	222
L3-03 (491H)	Stall Prevention Limit during Acceleration	<b>V/f</b> <b>OLV/PM</b> Sets Stall Prevention lower limit during acceleration when operating in the constant power range. Set as a percentage of the drive's rated current.	Default: 50% Min: 0% Max: 100%	222
L3-04 (492H)	Stall Prevention Selection during Deceleration	<b>All Modes</b> 0: Disabled. Deceleration at the active deceleration rate. An ov fault may occur. 1: General-purpose Stall Prevention. Deceleration is paused when the DC bus voltage exceeds the Stall Prevention level. 2: Intelligent Stall Prevention. Decelerate as fast as possible while avoiding ov faults. 4: Overexcitation Deceleration 1. Decelerates while increasing the motor flux. 5: Overexcitation Deceleration 2. Adjust the deceleration rate according to the DC bus voltage.	Default: 1 Min: 0 Max: 5 <34>	223
L3-05 (493H)	Stall Prevention Selection during Run	<b>All Modes</b> 0: Disabled. Drive runs at a set frequency. A heavy load may cause speed loss. 1: Decelerate using C1-02. 2: Decelerate using C1-04.	Default: 1 Min: 0 Max: 2	224
L3-06 (494H)	Stall Prevention Level during Run	<b>All Modes</b> Enabled when L3-05 is set to 1 or 2. 100% is equal to the drive rated current.	Default: <35> Min: 30% Max: 150% <35>	224
L3-11 (4C7H)	Overvoltage Suppression Function Selection	<b>All Modes</b> Enables or disables the ov suppression function, which allows the drive to change the output frequency as the load changes to prevent an ov fault. 0: Disabled 1: Enabled	Default: 0 Min: 0 Max: 1	225

## B.3 Parameter Table

No. (Addr.)	Name	Description	Setting	Page
L3-17 (462H) <18>	Target DC Bus Voltage for Overvoltage Suppression and Stall Prevention	<b>All Modes</b> Sets the desired value for the DC bus voltage during overvoltage suppression and Stall Prevention during deceleration.	Default: 370 Vdc <33> Min: 150 Vdc Max: 400 Vdc <33>	225
L3-20 (465H)	DC Bus Voltage Adjustment Gain	<b>All Modes</b> Sets the proportional gain for KEB Ride-Thru, Stall Prevention, and overvoltage suppression.	Default: <10> Min: 0.00 Max: 5.00	225
L3-21 (466H)	Accel/Decel Rate Calculation Gain	<b>All Modes</b> Sets the proportional gain used to calculate the deceleration rate during KEB Ride-Thru, ov suppression function, and Stall Prevention during deceleration (L3-04 = 2).	Default: <10> Min: 0.10 Max: 10.00	226
L3-22 (4F9H)	Deceleration Time at Stall Prevention during Acceleration	<b>V/f</b> <b>OLV/PM</b> Sets the deceleration time used for Stall Prevention during acceleration in OLV/PM.	Default: 0.0 s Min: 0.0 s Max: 6000 s	223
L3-23 (4FDH)	Automatic Reduction Selection for Stall Prevention during Run	<b>V/f</b> <b>OLV/PM</b> 0: Disabled. Sets the Stall Prevention level set in L3-06 that is used throughout the entire frequency range. 1: Enabled. Automatic Stall Prevention level reduction in the constant output range. The lower limit value is 40% of L3-06.	Default: 0 Min: 0 Max: 1	224
L3-24 (46EH)	Motor Acceleration Time for Inertia Calculations	<b>All Modes</b> Sets the time needed to accelerate the uncoupled motor at rated torque from stop to the maximum frequency.	Default: <8> <9> <14> Min: 0.001 s Max: 10.000 s	226
L3-25 (46FH)	Load Inertia Ratio	<b>All Modes</b> Sets the ratio between the motor and machine inertia.	Default: 1.0 Min: 1.0 Max: 1000.0	226
L3-26 (455H)	Additional DC Bus Capacitors	<b>All Modes</b> When DC bus capacitors have been added externally, be sure to add those values to the internal capacitor table for proper DC bus calculations. <b>Note:</b> Setting unit is mF in models CIMR-E□4A0930 and 4A1200.	Default: 0 μF Min: 0 μF Max: 65000 μF	227
L3-27 (456H)	Stall Prevention Detection Time	<b>All Modes</b> Sets the time the current must exceed the Stall Prevention level to activate Stall Prevention.	Default: 50 ms Min: 0 ms Max: 5000 ms	227

<8> Parameter value is changed if E2-11 is manually changed or changed by Auto-Tuning.

<9> Default setting is determined by the drive model (o2-04).

<10> Default setting is determined by the control mode (A1-02).

<14> Default setting value is dependent on the motor code set to parameter E5-01.

<18> Values shown here are for 200 V class drives. Double the value when using a 400 V class drive.

<33> Default setting value is dependent on the setting for the input voltage (E1-01).

<34> The setting range is 0 to 2 in OLV/PM control mode.

<35> The upper limit of the setting range is determined by the values set to the carrier frequency reduction selection (L8-38).

### ■ L4: Speed Detection

No. (Addr.)	Name	Description	Setting	Page
L4-01 (499H)	Speed Agreement Detection Level	<b>All Modes</b> L4-01 sets the frequency detection level for digital output functions H2-□□ = 2, 3, 4, 5.	Default: <10> Min: 0.0 Hz Max: 200.0 Hz	227
L4-02 (49AH)	Speed Agreement Detection Width	L4-02 sets the hysteresis or allowable margin for speed detection.	Default: <10> Min: 0.0 Hz Max: 20.0 Hz	227
L4-03 (49BH)	Speed Agreement Detection Level (+/-)	<b>All Modes</b> L4-03 sets the frequency detection level for digital output functions H2-□□ = 13, 14, 15, 16.	Default: 0.0 Hz Min: -200.0 Hz Max: 200.0 Hz	227
L4-04 (49CH)	Speed Agreement Detection Width (+/-)	L4-04 sets the hysteresis or allowable margin for speed detection.	Default: <10> Min: 0.0 Hz Max: 20.0 Hz	227
L4-05 (49DH)	Frequency Reference Loss Detection Selection	<b>All Modes</b> 0: Stop. Drive stops when the frequency reference is lost. 1: Continue operation with reduced frequency reference at L4-06 setting.	Default: 1 Min: 0 Max: 1	228
L4-06 (4C2H)	Frequency Reference at Reference Loss	<b>All Modes</b> Sets the percentage of the frequency reference that the drive should run with when the frequency reference is lost.	Default: 80% Min: 0.0% Max: 100.0%	228
L4-07 (470H)	Speed Agreement Detection Selection	<b>All Modes</b> 0: No detection during baseblock. 1: Detection always enabled.	Default: 0 Min: 0 Max: 1	228

<10> Default setting is determined by the control mode (A1-02).



## ■ L5: Fault Restart

No. (Addr.)	Name	Description	Setting	Page
L5-01 (49EH)	Number of Auto Restart Attempts	<b>All Modes</b> Sets the number of times the drive may attempt to restart after the following faults occur: GF, LF, oC, ov, PF, oL1, oL2, oL3, STo, Uv1.	Default: 0 Min: 0 Max: 10	229
L5-02 (49FH)	Auto Restart Fault Output Operation Selection	<b>All Modes</b> 0: Fault output not active. 1: Fault output active during restart attempt.	Default: 0 Min: 0 Max: 1	229
L5-03 (4A0H)	Time to Continue Making Fault Restarts	<b>All Modes</b> Although the drive will continue to execute fault restarts, this parameter will cause a fault if a fault restart cannot occur after the time in L5-03 passes. (enabled only when L5-05 = 0)	Default: 180.0 s Min: 0.0 s Max: 600.0 s	229
L5-04 (46CH)	Fault Reset Interval Time	<b>All Modes</b> Sets the amount of time to wait between performing fault restarts.	Default: 10.0 s Min: 0.5 s Max: 600.0 s	230
L5-05 (467H)	Fault Reset Operation Selection	<b>All Modes</b> 0: Count successful restarts. 1: Count restart attempts.	Default: 0 Min: 0 Max: 1	230

## ■ L6: Torque Detection

No. (Addr.)	Name	Description	Setting	Page
L6-01 (4A1H)	Torque Detection Selection	<b>All Modes</b> 0: Disabled 1: oL3 detection only active during speed agree, operation continues after detection 2: oL3 detection always active during run, operation continues after detection 3: oL3 detection only active during speed agree, output shuts down on an oL3 fault 4: oL3 detection always active during run, output shuts down on an oL3 fault 5: UL3 detection only active during speed agree, operation continues after detection 6: UL3 detection always active during run, operation continues after detection 7: UL3 detection only active during speed agree, output shuts down on an oL3 fault 8: UL3 detection always active during run, output shuts down on an oL3 fault 9: UL6 at speed agree (alarm) 10: UL6 at run (alarm) 11: UL6 at speed agree (fault) 12: UL6 at run - (fault)	Default: 0 Min: 0 Max: 12	231
L6-02 (4A2H)	Torque Detection Level	<b>All Modes</b> Sets the overtorque and undertorque detection level.	Default: 15% Min: 0% Max: 300%	232
L6-03 (4A3H)	Torque Detection Time	<b>All Modes</b> Sets the time an overtorque or undertorque condition must exist to trigger torque detection 1.	Default: 10.0s Min: 0.0 s Max: 10.0 s	232
L6-13 (62EH)	Motor Underload Protection Selection	<b>All Modes</b> Sets the motor underload protection (UL□) based on motor load. 0: Overtorque/Undertorque Detection Enabled 1: Base Frequency Motor load Enabled 2: Maximum Frequency Motor Load Enabled	Default: 0 Min: 0 Max: 2	233
L6-14 (62FH)	Motor Underload Protection Level at Minimum Frequency	<b>All Modes</b> Sets the UL6 detection level at minimum frequency by percentage of drive rated current.	Default: 15% Min: 0% Max: 300%	233

## ■ L8: Drive Protection

No. (Addr.)	Name	Description	Setting	Page
L8-02 (4AEH)	Overheat Alarm Level	<b>All Modes</b> An overheat alarm will occur if the heatsink temperature exceeds the level set in L8-02.	Default: <9> Min: 50°C Max: 130°C	233
L8-03 (4AFH)	Overheat Pre-Alarm Operation Selection	<b>All Modes</b> 0: Ramp to stop. A fault is triggered. 1: Coast to stop. A fault is triggered. 2: Fast Stop. Decelerate to stop using the deceleration time in C1-09. A fault is triggered. 3: Alarm only 4: Operation with reduced speed	Default: 3 Min: 0 Max: 4	234
L8-05 (4B1H)	Input Phase Loss Protection Selection	<b>All Modes</b> Selects the detection of input current phase loss, power supply voltage imbalance, or main circuit electrolytic capacitor deterioration. 0: Disabled 1: Enabled	Default: 1 Min: 0 Max: 1	235

## B.3 Parameter Table

No. (Addr.)	Name	Description	Setting	Page
L8-06 (4A2H)	Input Phase Detection Level	<p><b>All Modes</b></p> <p>When ripple is observed in the DC bus, expansion of the input bias is calculated and becomes the input phase if the difference between the max and minimum values of the ripple are greater than L8-06.            Detection Level = 100% = Voltage class <math>\times \sqrt{2}</math></p>	Default: <9> Min: 0.0 Max: 50.0	xx
L8-07 (4B3H)	Output Phase Loss Protection Selection	<p><b>All Modes</b></p> <p>0: Disabled            1: Enable (triggered when single phase is lost)            2: Enabled (triggered when two phases are lost)</p>	Default: 0 Min: 0 Max: 2	235
L8-09 (4B5H)	Output Ground Fault Detection Selection	<p><b>All Modes</b></p> <p>0: Disabled            1: Enabled</p>	Default: <9> Min: 0 Max: 1	235
L8-10 (4B6H)	Heatsink Cooling Fan Operation Selection	<p><b>All Modes</b></p> <p>0: Run with timer. Fan operates only during run and for L8-11 seconds after stop.            1: Run always. Cooling fan operates whenever the drive is powered up.</p>	Default: 0 Min: 0 Max: 1	236
L8-11 (4B7H)	Heatsink Cooling Fan Off-Delay Time	<p><b>All Modes</b></p> <p>Sets a delay time to shut off the cooling fan after the Run command is removed when L8-10 = 0.</p>	Default: 60 s Min: 0 s Max: 300 s	236
L8-12 (4B8H)	Ambient Temperature Setting	<p><b>All Modes</b></p> <p>Enter the ambient temperature. This value adjusts the oL2 detection level.</p>	Default: 40°C Min: -10°C Max: 50°C	236
L8-15 (4BBH)	oL2 Characteristics Selection at Low Speeds	<p><b>All Modes</b></p> <p>0: Protection disabled at low speed.            1: Protection enabled at low speed.</p>	Default: 1 Min: 0 Max: 1	236
L8-18 (4BEH)	Software Current Limit Selection	<p><b>V/f</b>   <b>OLV/PM</b></p> <p>0: Software CLA disabled (gain=0)            1: Software CLA enabled</p>	Default: 0 Min: 0 Max: 1	236
L8-19 (4BFH)	Frequency Reduction Rate during Overheat Pre-Alarm	<p><b>All Modes</b></p> <p>Specifies the frequency reference reduction gain at overheat pre-alarm when L8-03 = 4.</p>	Default: 0.8 Min: 0.1 Max: 0.9	234
L8-27 (4DDH)	Overcurrent Detection Gain	<p><b>V/f</b>   <b>OLV/PM</b></p> <p>Sets the gain for overcurrent detection as a percentage of the motor rated current. Overcurrent is detected using the drive's overcurrent level or the value set to L8-27, whichever is lower.</p>	Default: 300.0% Min: 0.0% Max: 300.0%	237
L8-29 (4DFH)	Current Unbalance Detection (LF2)	<p><b>V/f</b>   <b>OLV/PM</b></p> <p>0: Disabled            1: Enabled</p>	Default: 1 Min: 0 Max: 1	237
L8-32 (4E1H)	Main Contactor and Cooling Fan Power Supply Failure Selection	<p><b>All Modes</b></p> <p>Determines the action the drive should take when a fault occurs with the internal cooling fan.            0: Ramp to stop with C1-02            1: Coast to stop            2: Ramp to stop with fast stop C1-09            3: Alarm only</p>	Default: 1 Min: 0 Max: 4	237
L8-35 (4ECH)	Installation Method Selection	<p><b>All Modes</b></p> <p>0: IP00 enclosure            1: Side-by-Side mounting            2: IP00 NEMA Type 1 enclosure            3: Finless drive or external heatsink installation</p>	Default: <3> <9> Min: 0 Max: 3	237
L8-38 (4EFH)	Carrier Frequency Reduction Selection	<p><b>All Modes</b></p> <p>0: Disabled            1: Enabled for output frequencies below 6 Hz            2: Enabled for the entire frequency range</p>	Default: <16> Min: 0 Max: 2	238
L8-40 (4F1H)	Carrier Frequency Reduction Off-Delay Time at Start	<p><b>All Modes</b></p> <p>Sets the time that the drive continues running with reduced carrier frequency after the carrier reduction condition is gone. Setting 0.00 s disables the carrier frequency reduction time.</p>	Default: <10> Min: 0.00 s Max: 2.00 s	238
L8-41 (4F2H)	High Current Alarm Selection	<p><b>All Modes</b></p> <p>0: Disabled            1: Enabled. An alarm is triggered at output currents above 150% of the drives rated current.</p>	Default: 0 Min: 0 Max: 1	238
L8-78 (2CCH)	Power Unit Output Phase Loss Protection	<p><b>All Modes</b></p> <p>Enables motor protection if output phase loss occurs.            0: Disabled            1: Enabled  <b>Note:</b> This parameter is available in models CIMR-E□4A0930 and 4A1200.</p>	Default: 1 Min: 0 Max: 1	239

<3> Parameter setting value is not reset to the default value when the drive is initialized.

<9> Default setting is determined by the drive model (o2-04).

<10> Default setting is determined by the control mode (A1-02).

<16> Default setting is determined by the control mode (A1-02) and the drive model (o2-04).

## ◆ n: Special Adjustments

The n parameters are used to adjust more advanced performance characteristics such as Hunting Prevention, and High Slip Braking.

### ■ n1: Hunting Prevention

No. (Addr.)	Name	Description	Setting	Page
n1-01 (580H)	Hunting Prevention Selection	<input type="checkbox"/> V/f <input type="checkbox"/> OLV/PM 0: Disabled 1: Enabled	Default: 1 Min: 0 Max: 1	240
n1-02 (581H)	Hunting Prevention Gain Setting	<input type="checkbox"/> V/f <input type="checkbox"/> OLV/PM If the motor vibrates while lightly loaded, increase the gain by 0.1 until vibration ceases. If the motor stalls, decrease the gain by 0.1 until the stalling ceases.	Default: 1.00 Min: 0.00 Max: 2.50	240
n1-03 (582H)	Hunting Prevention Time Constant	<input type="checkbox"/> V/f <input type="checkbox"/> OLV/PM Sets the time constant used for Hunting Prevention.	Default: <6> Min: 0 ms Max: 500 ms	240
n1-05 (530H)	Hunting Prevention Gain while in Reverse	<input type="checkbox"/> V/f <input type="checkbox"/> OLV/PM Sets the gain used for Hunting Prevention. If set to 0, the gain set to n1-02 is used for operation in reverse.	Default: 0.00 Min: 0.00 Max: 2.50	240

<6> Default setting value varies by the drive model (o2-04).

### ■ n3: High Slip Braking (HSB) and Overexcitation Braking

No. (Addr.)	Name	Description	Setting	Page
n3-01 (588H)	High Slip Braking Deceleration Frequency Width	<input type="checkbox"/> V/f <input type="checkbox"/> OLV/PM Sets the output frequency reduction step width for when the drive stops the motor using HSB. Set as a percentage of the maximum output frequency. Increase this setting if overvoltage occurs during HSB.	Default: 5% Min: 1% Max: 20%	241
n3-02 (589H)	High Slip Braking Current Limit	<input type="checkbox"/> V/f <input type="checkbox"/> OLV/PM Sets the current limit during HSB as a percentage of the motor rated current.	Default: <35> Min: 100% Max: 200%	241
n3-03 (58AH)	High Slip Braking Dwell Time at Stop	<input type="checkbox"/> V/f <input type="checkbox"/> OLV/PM Sets the time the drive will run with minimum frequency (E1-09) at the end of deceleration. If this time is set too low, the machine inertia can cause the motor to rotate slightly after HSB.	Default: 1.0 s Min: 0.0 s Max: 10.0 s	241
n3-04 (58BH)	High Slip Braking Overload Time	<input type="checkbox"/> V/f <input type="checkbox"/> OLV/PM Sets the time required for an HSB overload fault (oL7) to occur when the drive output frequency does not change during an HSB stop. This parameter does not typically require adjustment.	Default: 40 s Min: 30 s Max: 1200 s	241
n3-13 (531H)	Overexcitation Deceleration Gain	<input type="checkbox"/> V/f <input type="checkbox"/> OLV/PM Sets the gain applied to the V/f pattern during Overexcitation Deceleration (L3-04 = 4).	Default: 1.10 Min: 1.00 Max: 1.40	242
n3-21 (579H)	High-Slip Suppression Current Level	<input type="checkbox"/> V/f <input type="checkbox"/> OLV/PM Sets output current level at which the drive will start reducing the overexcitation gain in order to prevent a too high motor slip during Overexcitation Deceleration. Set as a percentage of the drive rated current.	Default: 100% Min: 0% Max: 150%	242
n3-23 (57BH)	Overexcitation Operation Selection	<input type="checkbox"/> V/f <input type="checkbox"/> OLV/PM 0: Overexcitation Operation disabled 1: Overexcitation Operation as Selected in L3-04 in Forward Direction Only 2: Overexcitation Operation as Selected in L3-04 in Reverse Direction Only	Default: 0 Min: 0 Max: 2	243

<35> The upper limit of the setting range is determined by the values set to the carrier frequency reduction selection (L8-38).

### ■ n8: PM Motor Control Tuning

No. (Addr.)	Name	Description	Setting	Page
n8-45 (538H)	Speed Feedback Detection Control Gain	<input type="checkbox"/> V/f <input type="checkbox"/> OLV/PM Increase this setting if hunting occurs. Decrease to lower the response.	Default: 0.80 Min: 0.00 Max: 10.00	243
n8-47 (53AH)	Pull-In Current Compensation Time Constant	<input type="checkbox"/> V/f <input type="checkbox"/> OLV/PM Sets the time constant to make the pull-in current reference and actual current value agree. Decrease the value if the motor begins to oscillate, and increase the value if it takes too long for the current reference to equal the output current.	Default: 5.0 s Min: 0.0 s Max: 100.0 s	243
n8-48 (53BH)	Pull-In Current	<input type="checkbox"/> V/f <input type="checkbox"/> OLV/PM Defines the d-axis current reference during no-load operation at a constant speed. Set as a percentage of the motor rated current. Increase this setting if hunting occurs while running at constant speed.	Default: 30% Min: 20% Max: 200%	243

## B.3 Parameter Table

No. (Addr.)	Name	Description	Setting	Page
n8-49 (53CH)	d-Axis Current for High Efficiency Control	 Sets the d-axis current reference when running a high load at constant speed. Set as a percentage of the motor rated current.	Default: <14> Min: -200.0% Max: 0.0%	243
n8-51 (53EH)	Acceleration/Deceleration Pull-In Current	 Sets the d-axis current reference during acceleration/deceleration as a percentage of the motor rated current. Set to a high value when more starting torque is needed.	Default: 50% Min: 0% Max: 200%	244
n8-54 (56DH)	Voltage Error Compensation Time Constant	 Adjusts the value when hunting occurs at low speed. If hunting occurs with sudden load changes, increase n8-54 in increments of 0.1. Reduce this setting if oscillation occurs at start.	Default: 1.00 s Min: 0.00 s Max: 10.00 s	244
n8-55 (56EH)	Load Inertia	 Sets the ratio between motor and machine inertia. 0: less than 1:10. 1: between 1:10 to 1:30. 2: between 1:30 to 1:50. 3: higher than 1:50.	Default: 0 Min: 0 Max: 3	244
n8-62 (57DH) <18>	Output Voltage Limit	 Prevents output voltage saturation. Should be set just below the voltage provided by the input power supply.	Default: 200.0 V Min: 0.0 V Max: 230.0 V	244
n8-65 (65CH)	Speed Feedback Detection Control Gain during ov Suppression	 Sets the gain used for internal speed feedback detection during ov suppression	Default: 1.50 Min: 0.00 Max: 10.00	245

<14> Default setting value is dependent on the motor code set to E5-01.

<18> Values shown here are for 200 V class drives. Double the value when using a 400 V class drive.

### ◆ o: Operator Related Settings

The o parameters are used to set up the digital operator displays.

#### ■ o1: Digital Operator Display Selection

No. (Addr.)	Name	Description	Setting	Page
o1-01 (500H) 	Drive Mode Unit Monitor Selection	 Selects the content of the last monitor that is shown when scrolling through Drive Mode display. Enter the last three digits of the monitor parameter number to be displayed: U□-□□.	Default: 106 (Monitor U1-06) Min: 105 Max: 825	246
o1-02 (501H) 	User Monitor Selection after Power Up	 1: Frequency reference (U1-01) 2: Motor direction 3: Output frequency (U1-02) 4: Output current (U1-03) 5: User-selected monitor (set by o1-01)	Default: 1 Min: 1 Max: 5	246
o1-03 (502H)	Digital Operator Display Selection	 Sets the units the drive should use to display the frequency reference and motor speed monitors. 0: 0.01 Hz units 1: 0.01% units (100% = E1-04) 2: r/min units (calculated using the number of motor poles setting in E2-04, or E5-04) 3: User-selected units (set by o1-10 and o1-11)	Default: <10> Min: 0 Max: 3	246
o1-06 (517H)	User Monitor Selection Mode	 0: 3 Monitor sequential (Displays the next 2 sequential Monitor) 1: 3 Monitor Selectable: o1-07,-08 selected monitor is shown	Default: 0 Min: 0 Max: 1	247
o1-07 (518H)	Second Line Monitor Selection	 Selects which monitor will be displayed in the second line. The monitor parameter number is entered into the spaces provided: U□-□□. For example, set "403" to display monitor parameter U4-03.	Default: 102 Min: 101 Max: 825	247
o1-08 (519H)	Third Line Monitor Selection	 Selects which monitor will be displayed in the second line. The monitor parameter number is entered into the spaces provided: U□-□□. For example, set "403" to display monitor parameter U4-03.	Default: 103 Min: 101 Max: 825	247
o1-10 (520H)	User-Set Display Units Maximum Value	 These settings define the display values when o1-03 is set to 3. o1-10 sets the display value that is equal to the maximum output frequency. o1-11 sets the position of the decimal position.	Default: <36> Min: 1 Max: 60000	247
o1-11 (521H)	User-Set Display Units Decimal Display	 0: No decimal point 1: One decimal point 2: Two decimal points 3: Three decimal points	Default: <36> Min: 0 Max: 3	247

<10> Default setting is determined by the control mode (A1-02).

<36> Default setting value is determined by the digital operator display selection (o1-03).

## o2: Digital Operator Keypad Functions

No. (Addr.)	Name	Description	Setting	Page
o2-01 (505H)	LO/RE Key Function Selection	<b>All Modes</b> 0: Disabled 1: Enabled. LO/RE key switches between LOCAL and REMOTE operation.	Default: 1 Min: 0 Max: 1	247
o2-02 (506H)	STOP Key Function Selection	<b>All Modes</b> 0: Disabled. STOP key is disabled in REMOTE operation. 1: Enabled. STOP key is always enabled.	Default: 1 Min: 0 Max: 1	248
o2-03 (507H)	User Parameter Default Value	<b>All Modes</b> 0: No change. 1: Set User Initialize Values. Saves parameter settings as default values for a User Initialization. 2: Clear User Initialize Values. Clears the default settings that have been saved for a User Initialization.	Default: 0 Min: 0 Max: 2	248
o2-04 (508H)	Drive Model Selection	<b>All Modes</b> Enter the drive model. Setting required only if installing a new control board.	Default: Determined by drive capacity Min: – Max: –	248
o2-05 (509H)	Frequency Reference Setting Method Selection	<b>All Modes</b> 0: ENTER key required. 1: ENTER key is not required. The frequency reference can be adjusted using the up and down arrow keys only.	Default: 0 Min: 0 Max: 1	249
o2-06 (50AH)	Operation Selection when Digital Operator is Disconnected	<b>All Modes</b> 0: Continue operation 1: Trigger a fault	Default: 0 Min: 0 Max: 1	249
o2-07 (527H)	Motor Direction at Power Up when Using Operator	<b>All Modes</b> 0: Forward 1: Reverse This parameter requires that drive operation be assigned to the digital operator.	Default: 0 Min: 0 Max: 1	249

## o3: Copy Function

No. (Addr.)	Name	Description	Setting	Page
o3-01 (515H)	Copy Function Selection	<b>All Modes</b> 0: Copy Select (no function) 1: INV→OP READ 2: OP→INV WRITE 3: OP↔INV VERIFY	Default: 0 Min: 0 Max: 3	249
o3-02 (516H)	Copy Allowed Selection	<b>All Modes</b> 0: Disabled 1: Enabled	Default: 0 Min: 0 Max: 1	250

## o4: Maintenance Monitor Settings

No. (Addr.)	Name	Description	Setting	Page
o4-01 (50BH)	Cumulative Operation Time Setting	<b>All Modes</b> Sets the value for the cumulative operation time of the drive in units of 10 h.	Default: 0 H Min: 0 H Max: 9999H	250
o4-02 (50CH)	Cumulative Operation Time Selection	<b>All Modes</b> 0: Power on time 1: Run time	Default: 0 Min: 0 Max: 1	250
o4-03 (50EH)	Cooling Fan Operation Time Setting	<b>All Modes</b> Sets the value of the fan operation time monitor U4-03 in units of 10 h.	Default: 0 H Min: 0 H Max: 9999H	250
o4-05 (51DH)	Capacitor Maintenance Setting	<b>All Modes</b> Sets the value of the Maintenance Monitor for the capacitors. See U4-05 to check when the capacitors may need to be replaced.	Default: 0% Min: 0% Max: 150%	250
o4-07 (523H)	DC Bus Pre-Charge Relay Maintenance Setting	<b>All Modes</b> Sets the value of the Maintenance Monitor for the soft charge bypass relay. See U4-06 to check when the bypass relay may need to be replaced.	Default: 0% Min: 0% Max: 150%	251
o4-09 (525H)	IGBT Maintenance Setting	<b>All Modes</b> Sets the value of the Maintenance Monitor for the IGBTs. See U4-07 to check when the IGBTs may need to be replaced.	Default: 0% Min: 0% Max: 150%	251
o4-11 (510H)	U2, U3 Initialization	<b>All Modes</b> 0: No action U2-□□ and U3-□□ monitor data is not reset when the drive is initialized (A1-03). 1: Reset fault data U2-□□ and U3-□□ monitor data is reset when the drive is initialized (A1-03).	Default: 0 Min: 0 Max: 1	251

## B.3 Parameter Table

No. (Addr.)	Name	Description	Setting	Page
o4-12 (512H)	kWh Monitor Initialization	<p><b>All Modes</b></p> <p>0: No action U4-10 and U4-11 monitor data is not reset when the drive is initialized (A1-03). 1: Reset kWh data U4-10 and U4-11 monitor data is reset when the drive is initialized (A1-03).</p>	Default: 0 Min: 0 Max: 1	251
o4-13 (528H)	Number of Run Commands Counter Initialization	<p><b>All Modes</b></p> <p>0: No action Number of Run commands counter is not reset when the drive is initialized (A1-03). 1: Reset the run command Counter. Number of Run commands counter is reset when the drive is initialized (A1-03).</p>	Default: 0 Min: 0 Max: 1	251

### ◆ q: DriveWorksEZ Parameters

No. (Addr.)	Name	Description	Setting	Page
q1-01 to q6-07 (1600H to 1746H)	DriveWorksEZ Parameters	<p><b>All Modes</b></p> <p>Reserved for DriveWorksEZ</p>	Refer to Help in the DWEZ software.	252

### ◆ r: DriveWorksEZ Connection Parameters

No. (Addr.)	Name	Description	Setting	Page
r1-01 to r1-40 (1840H to 1867H)	DriveWorksEZ Connection Parameters 1 to 20 (upper/lower)	<p><b>All Modes</b></p> <p>DriveWorksEZ Connection Parameters 1 to 20 (upper/lower)</p>	Default: 0 Min: 0 Max: FFFFH	252

### ◆ T: Motor Tuning

Enter data into the following parameters to tune the motor and drive for optimal performance

#### ■ T1: Induction Motor Auto-Tuning

No. (Addr.)	Name	Description	Setting	Page
T1-01 (701H) <37>	Auto-Tuning Mode Selection	<p><b>V/f</b>   <b>OLV/PM</b></p> <p>2: Stationary Auto-Tuning for Line-to-Line Resistance 3: Rotational Auto-Tuning for V/f Control (necessary for Energy Savings and Speed Estimation Speed Search)</p>	Default: 2 Min: 2 Max: 3 <10>	116
T1-02 (702H)	Motor Rated Power	<p><b>V/f</b>   <b>OLV/PM</b></p> <p>Sets the motor rated power as specified on the motor nameplate. <b>Note:</b> Use the following formula to convert horsepower into kilowatts: kW = HP x 0.746.</p>	Default: <6> Min: 0.00 kW Max: 650.00 kW	116
T1-03 (703H) <18>	Motor Rated Voltage	<p><b>V/f</b>   <b>OLV/PM</b></p> <p>Sets the motor rated voltage as specified on the motor nameplate.</p>	Default: 200.0 V Min: 0.0 V Max: 255.0 V	117
T1-04 (704H)	Motor Rated Current	<p><b>V/f</b>   <b>OLV/PM</b></p> <p>Sets the motor rated current as specified on the motor nameplate.</p>	Default: <6> Min: 10% of drive rated current Max: 200% of drive rated current	117
T1-05 (705H)	Motor Base Frequency	<p><b>V/f</b>   <b>OLV/PM</b></p> <p>Sets the rated frequency of the motor as specified on the motor nameplate.</p>	Default: 50.0 Hz Min: 0.0 Hz Max: 200.0 Hz	117
T1-06 (706H)	Number of Motor Poles	<p><b>V/f</b>   <b>OLV/PM</b></p> <p>Sets the number of motor poles as specified on the motor nameplate.</p>	Default: 4 Min: 2 Max: 48	117
T1-07 (707H)	Motor Base Speed	<p><b>V/f</b>   <b>OLV/PM</b></p> <p>Sets the rated speed of the motor as specified on the motor nameplate.</p>	Default: 1450 r/min Min: 0 r/min Max: 24000 r/min	117
T1-11 (70BH)	Motor Iron Loss	<p><b>V/f</b>   <b>OLV/PM</b></p> <p>Sets the iron loss for determining the Energy Saving coefficient. The value is set to E2-10 (motor iron loss) set when the power is cycled. If T1-02 is changed, a default value appropriate for the motor capacity that was entered will appear.</p>	Default: <38> Min: 0 W Max: 65535 W	117

<6> Default setting value varies by the drive model (o2-04).

<10> Default setting is determined by the control mode (A1-02).

<18> Values shown here are for 200 V class drives. Double the value when using a 400 V class drive.

<37> The availability of certain Auto-Tuning methods depends on the control mode selected for the drive.

<38> Default setting value differs depending on the motor code value and motor parameter settings.

## ■ T2: PM Motor Auto-Tuning

No. (Addr.)	Name	Description	Setting	Page
T2-01 (750H)	PM Motor Auto-Tuning Mode Selection	<input type="radio"/> V/f <input type="radio"/> OLV/PM 0: PM Motor Parameter Settings 1: PM Stationary Auto-Tuning 2: PM Stationary Auto-Tuning for Stator Resistance	Default: 0 Min: 0 Max: 2 <10>	118
T2-02 (751H)	PM Motor Code Selection	<input type="radio"/> V/f <input type="radio"/> OLV/PM Enter the motor code when using a Yaskawa PM motor. Once the motor code is entered, the drive automatically sets parameters T2-03 through T2-14. When using a motor that is not supported motor code or a non-Yaskawa motor, set FFFF here and then adjust the other T2 parameters according the motor nameplate or the motor test report.	Default: <16> Min: 0000 Max: FFFF	118
T2-03 (752H)	PM Motor Type	<input type="radio"/> V/f <input type="radio"/> OLV/PM 0: IPM motor 1: SPM motor. Parameter T2-17 will not be displayed with this setting.	Default: 1 Min: 0 Max: 1	118
T2-04 (730H)	PM Motor Rated Power	<input type="radio"/> V/f <input type="radio"/> OLV/PM Sets the motor rated power. <b>Note:</b> Use the following formula to convert horsepower into kilowatts: kW = HP x 0.746.	Default: <6> Min: 0.00 kW Max: 650.00 kW	118
T2-05 (732H) <18>	PM Motor Rated Voltage	<input type="radio"/> V/f <input type="radio"/> OLV/PM Enter the motor rated voltage as indicated on the motor nameplate.	Default: 200.0 V Min: 0.0 V Max: 255.0 V	118
T2-06 (733H)	PM Motor Rated Current	<input type="radio"/> V/f <input type="radio"/> OLV/PM Enter the motor rated current as indicated on the motor nameplate.	Default: <6> Min: 10% of drive rated current Max: 200% of drive rated current	118
T2-07 (753H)	PM Motor Base Frequency	<input type="radio"/> V/f <input type="radio"/> OLV/PM Enter the motor base frequency as indicated on the motor nameplate.	Default: 87.5 Hz Min: 0.0 Hz Max: 200.0 Hz	119
T2-08 (734H)	Number of PM Motor Poles	<input type="radio"/> V/f <input type="radio"/> OLV/PM Enter the number of motor poles for the PM motor as indicated on the motor nameplate.	Default: 6 Min: 2 Max: 48	119
T2-10 (754H)	PM Motor Stator Resistance	<input type="radio"/> V/f <input type="radio"/> OLV/PM Enter the rotor resistance for the PM motor as indicated on the motor nameplate.	Default: <39> Min: 0.000 Ω Max: 65.000 Ω	119
T2-11 (735H)	PM Motor d-Axis Inductance	<input type="radio"/> V/f <input type="radio"/> OLV/PM Enter the d-axis inductance for the PM motor as indicated on the motor nameplate.	Default: <39> Min: 0.00 mH Max: 600.00 mH	119
T2-12 (736H)	PM Motor q-Axis Inductance	<input type="radio"/> V/f <input type="radio"/> OLV/PM Enter the q-axis inductance for the PM motor as indicated on the motor nameplate.	Default: <39> Min: 0.00 mH Max: 600.00 mH	119
T2-13 (755H)	Induced Voltage Constant Unit Selection	<input type="radio"/> V/f <input type="radio"/> OLV/PM 0: mV/(r/min). E5-09 will automatically be set to 0.0, and E5-24 will be used. 1: mV/(rad/sec). E5-24 will automatically be set to 0.0, and E5-09 will be used	Default: 1 Min: 0 Max: 1	119
T2-14 (737H)	PM Motor Induced Voltage Constant	<input type="radio"/> V/f <input type="radio"/> OLV/PM Enter the induced voltage coefficient for the PM motor as indicated on the motor nameplate.	Default: <39> Min: 0.1 Max: 2000.0	119
T2-15 (756H)	Pull-In Current Level for PM Motor Tuning	<input type="radio"/> V/f <input type="radio"/> OLV/PM Sets the amount of pull-in current to use for Auto-Tuning as a percentage of the motor rated current. Increase this setting for high inertia loads.	Default: 30% Min: 0% Max: 120%	119

<6> Default setting value varies by the drive model (o2-04).

<10> Default setting is determined by the control mode (A1-02).

<16> Default setting is determined by the control mode (A1-02) and the drive model (o2-04).

<18> Values shown here are for 200 V class drives. Double the value when using a 400 V class drive.

<39> Default setting is determined by the drive capacity and the motor code selected in T2-02.

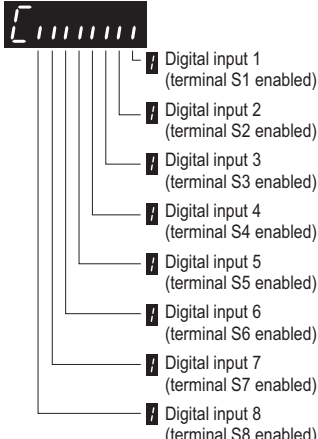
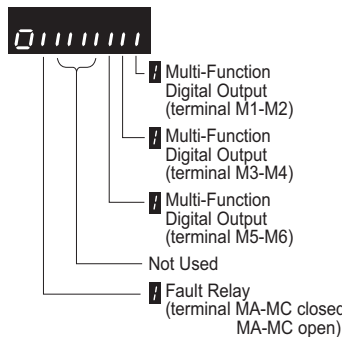
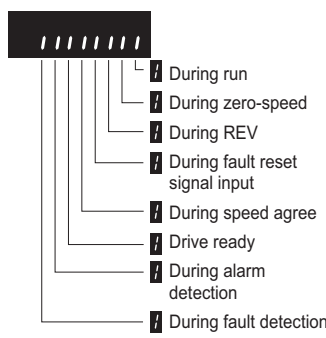
## ◆ U: Monitors

Monitor parameters allow the user to view drive status, fault information, and other data concerning drive operation.

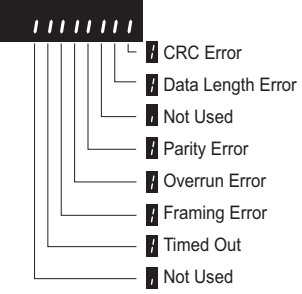
### ■ U1: Operation Status Monitors

No. (Addr.)	Name	Description	Analog Output Level	Unit	Page
U1-01 (40H)	Frequency Reference	<input type="radio"/> All Modes Monitors the frequency reference. Display units are determined by o1-03.	10 V: Max frequency	0.01 Hz	–
U1-02 (41H)	Output Frequency	<input type="radio"/> All Modes Displays the output frequency. Display units are determined by o1-03.	10 V: Max frequency	0.01 Hz	–

### B.3 Parameter Table

No. (Addr.)	Name	Description	Analog Output Level	Unit	Page
U1-03 (42H)	Output Current	<p><b>All Modes</b></p> <p>Displays the output current.  <b>Note:</b>The unit is expressed in 1 A for models CIMR-E□4A0930 and 4A1200.</p>	10 V: Drive rated current	<19> <50>	-
U1-04 (43H)	Control Method	<p><b>All Modes</b></p> <p>0: V/f Control            5: Open Loop Vector Control for PM</p>	No signal output available	-	-
U1-06 (45H)	Output Voltage Reference	<p><b>All Modes</b></p> <p>Displays the output voltage.</p>	10 V: 200 Vrms <18>	0.1 Vac	-
U1-07 (46H)	DC Bus Voltage	<p><b>All Modes</b></p> <p>Displays the DC bus voltage.</p>	10 V: 400 V <18>	1 Vdc	-
U1-08 (47H)	Output Power	<p><b>All Modes</b></p> <p>Displays the output power (this value is calculated internally).</p>	10 V: Drive capacity (motor capacity) kW	<22>	-
U1-10 (49H)	Input Terminal Status	<p><b>All Modes</b></p> <p>Displays the input terminal status.</p>  <ul style="list-style-type: none"> <li>■ Digital input 1 (terminal S1 enabled)</li> <li>■ Digital input 2 (terminal S2 enabled)</li> <li>■ Digital input 3 (terminal S3 enabled)</li> <li>■ Digital input 4 (terminal S4 enabled)</li> <li>■ Digital input 5 (terminal S5 enabled)</li> <li>■ Digital input 6 (terminal S6 enabled)</li> <li>■ Digital input 7 (terminal S7 enabled)</li> <li>■ Digital input 8 (terminal S8 enabled)</li> </ul>	No signal output available	-	-
U1-11 (4AH)	Output Terminal Status	<p><b>All Modes</b></p> <p>Displays the output terminal status.</p>  <ul style="list-style-type: none"> <li>■ Multi-Function Digital Output (terminal M1-M2)</li> <li>■ Multi-Function Digital Output (terminal M3-M4)</li> <li>■ Multi-Function Digital Output (terminal M5-M6)</li> <li>Not Used</li> <li>■ Fault Relay (terminal MA-MC closed MA-MC open)</li> </ul>	No signal output available	-	-
U1-12 (4BH)	Drive Status	<p><b>All Modes</b></p> <p>Verifies the drive operation status.</p>  <ul style="list-style-type: none"> <li>■ During run</li> <li>■ During zero-speed</li> <li>■ During REV</li> <li>■ During fault reset signal input</li> <li>■ During speed agree</li> <li>■ Drive ready</li> <li>■ During alarm detection</li> <li>■ During fault detection</li> </ul>	No signal output available	-	-
U1-13 (4EH)	Terminal A1 Input Level	<p><b>All Modes</b></p> <p>Displays the signal level to analog input terminal A1.</p>	10 V: 100%	0.1%	-



No. (Addr.)	Name	Description	Analog Output Level	Unit	Page
U1-14 (4FH)	Terminal A2 Input Level	<b>All Modes</b> Displays the signal level to analog input terminal A2.	10 V: 100%	0.1%	–
U1-15 (50H)	Terminal A3 Input Level	<b>All Modes</b> Displays the signal level to analog input terminal A3.	10 V: 100%	0.1%	–
U1-16 (53H)	Output Frequency after Soft Starter	<b>All Modes</b> Displays output frequency with ramp time and S-curves. Units determined by o1-03.	10 V: Max frequency	0.01 Hz	–
U1-18 (61H)	oPE Fault Parameter	<b>All Modes</b> Displays the parameter number that caused the oPE□□ or Err (EEPROM write error) error.	No signal output available	–	–
U1-19 (66H)	MEMOBUS/Modbus Error Code	<b>All Modes</b> Displays the contents of a MEMOBUS/Modbus error. 	No signal output available	–	–
U1-24 (7DH)	Input Pulse Monitor	<b>All Modes</b> Displays the frequency to pulse train input terminal RP.	Determined by H6-02	1 Hz	–
U1-25 (4DH)	Software Number (Flash)	<b>All Modes</b> FLASH ID	No signal output available	–	–
U1-26 (5BH)	Software No. (ROM)	<b>All Modes</b> ROM ID	No signal output available	–	–
U1-29 (7AAH)	Software No. (PWM)	<b>All Modes</b> PWM ID <b>Note:</b> This parameter is displayed in models CIMR-E□4A0930 and 4A1200.	No signal output available	–	–

<18> Values shown here are for 200 V class drives. Double the value when using a 400 V class drive.

<19> This value's number of decimal places depends on the drive model. The value will have two decimal places (0.01 A) if the drive model is CIMR-E□2A0004 to 2A0040, 4A0002 to 4A0023 and one decimal place (0.1 A) if the drive model is CIMR-E□2A0056 to 2A0415, 4A0031 to 4A1200.

<22> Drives with a maximum output up to 11 kW will display this value in units of 0.01 kW (two decimal places). Drives with a maximum output greater than 11 kW will display this value in units of 0.1 kW (one decimal place). *Refer to Model Number and Nameplate Check on page 29* for details.

<50> When reading the value of this monitor via MEMOBUS/Modbus a value of 8192 is equal to 100% of the drive rated output current.

## ■ U2: Fault Trace

No. (Addr.)	Name	Description	Analog Output Level	Unit	Page
U2-01 (80H)	Current Fault	<b>All Modes</b> Displays the current fault.	No signal output available	–	–
U2-02 (81H)	Previous Fault	<b>All Modes</b> Displays the previous fault.	No signal output available	–	–
U2-03 (82H)	Frequency Reference at Previous Fault	<b>All Modes</b> Displays the frequency reference at the previous fault.	No signal output available	0.01 Hz	–
U2-04 (83H)	Output Frequency at Previous Fault	<b>All Modes</b> Displays the output frequency at the previous fault.	No signal output available	0.01 Hz	–
U2-05 (84H)	Output Current at Previous Fault	<b>All Modes</b> Displays the output current at the previous fault. <b>Note:</b> The unit is expressed in 1 A for models CIMR-E□4A0930 and 4A1200.	No signal output available	<19> <50>	–
U2-07 (86H)	Output Voltage at Previous Fault	<b>All Modes</b> Displays the output voltage at the previous fault.	No signal output available	0.1 Vac	–
U2-08 (87H)	DC Bus Voltage at Previous Fault	<b>All Modes</b> Displays the DC bus voltage at the previous fault.	No signal output available	1 Vdc	–
U2-09 (88H)	Output Power at Previous Fault	<b>All Modes</b> Displays the output power at the previous fault.	No signal output available	0.1 kW	–

## B.3 Parameter Table

No. (Addr.)	Name	Description	Analog Output Level	Unit	Page
U2-11 (8AH)	Input Terminal Status at Previous Fault	<b>All Modes</b> Displays the input terminal status at the previous fault. Displayed as in U1-10.	No signal output available	–	–
U2-12 (8BH)	Output Terminal Status at Previous Fault	<b>All Modes</b> Displays the output status at the previous fault. Displays the same status displayed in U1-11.	No signal output available	–	–
U2-13 (8CH)	Drive Operation Status at Previous Fault	<b>All Modes</b> Displays the operation status of the drive at the previous fault. Displays the same status displayed in U1-12.	No signal output available	–	–
U2-14 (8DH)	Cumulative Operation Time at Previous Fault	<b>All Modes</b> Displays the cumulative operation time at the previous fault.	No signal output available	1 h	–
U2-15 (7E0H)	Soft Starter Speed Reference at Previous Fault	<b>All Modes</b> Displays the speed reference for the soft starter at the previous fault. This parameter is valid from the drive software version S3801 and later.	No signal output available	0.01 Hz	–
U2-16 (7E1H)	Motor q-Axis Current at Previous Fault	<b>V/f</b> <b>OLV/PM</b> Displays the q-axis current for the motor at the previous fault. This parameter is valid from the drive software version S3801 and later. <b>Note:</b> Available control modes for parameter U2-16 vary by drive model: CIMR-E□2A0004 to 2A0415 and 4A0002 to 4A0675: Available when A1-02 = 5 CIMR-E□4A0930 and 4A1200: Available when A1-02 = 0,1	No signal output available	0.10%	–
U2-17 (7E2H)	Motor d-Axis Current at Previous Fault	<b>V/f</b> <b>OLV/PM</b> Displays the d-axis current for the motor at the previous fault. This parameter is valid from the drive software version S3801 and later.	No signal output available	0.10%	–
U2-20 (8EH)	Heatsink Temperature at Previous Fault	<b>All Modes</b> Displays the temperature of the heatsink when the most recent fault occurred.	No signal output available	1°C	–
U2-27 (7FAH)	Motor Temperature at Previous Fault (NTC)	<b>All Modes</b> Displays the temperature of the motor when the most recent fault occurred. <b>Note:</b> This parameter is available in models CIMR-E□4A0930 and 4A1200.	No signal output available	1°C	–
U2-28 (7FCH)	Malfunctioned Module	<b>All Modes</b> Display the module where the previous fault occurred at a decimal number. <b>Note:</b> This parameter is available in models CIMR-E□4A0930 and 4A1200.	No signal output available	–	–

<19> This value's number of decimal places depends on the drive model. The value will have two decimal places (0.01 A) if the drive model is CIMR-E□2A0004 to 2A0040, 4A0002 to 4A0023 and one decimal place (0.1 A) if the drive model is CIMR-E□2A0056 to 2A0415, 4A0031 to 4A1200.

<50> When reading the value of this monitor via MEMOBUS/Modbus a value of 8192 is equal to 100% of the drive rated output current.

### ■ U3: Fault History

No. (Addr.)	Name	Description	Analog Output Level	Unit	Page
U3-01 to U3-04 (90H to 93H (800H to 803H))	First to 4th Most Recent Fault	<b>All Modes</b> Displays the first to the fourth most recent faults.	No signal output available	–	–
U3-05 to U3-10 (804H to 809H)	5th to 10th Most Recent Fault	<b>All Modes</b> Displays the fifth to the tenth most recent faults. After ten faults have occurred in the drive, data for the oldest fault is deleted. The most recent fault appears in U3-01, with the next most recent fault appearing in U3-02. The data is moved to the next monitor parameter every time a fault occurs.	No signal output available	–	–
U3-11 to U3-14 (94H to 97H (80AH to 80DH))	Cumulative Operation Time at 1st to 4th Most Recent Fault	<b>All Modes</b> Displays the cumulative operation time when the first to the fourth most recent faults occurred.	No signal output available	1 h	–
U3-15 to U3-20 (80EH to 813H)	Cumulative Operation Time at 5th to 10th Most Recent Fault	<b>All Modes</b> Displays the cumulative operation time when the fifth to the tenth most recent faults occurred.	No signal output available	1 h	–

### ■ U4: Maintenance Monitors

No. (Addr.)	Name	Description	Analog Output Level	Unit	Page
U4-01 (4CH)	Cumulative Operation Time	<b>All Modes</b> Displays the cumulative operation time of the drive. The value for the cumulative operation time counter can be reset in parameter o4-01. Use parameter o4-02 to determine if the operation time should start as soon as the power is switched on or only while the Run command is present. The maximum number displayed is 99999, after which the value is reset to 0.	No signal output available	1 h	–

No. (Addr.)	Name	Description	Analog Output Level	Unit	Page
U4-02 (75H)	Number of Run Commands	<b>All Modes</b> Displays the number of times the Run command is entered. Reset the number of Run commands using parameter o4-13. This value will reset to 0 and start counting again after reaching 65535.	No signal output available	1 Time	–
U4-03 (67H)	Cooling Fan Operation Time	<b>All Modes</b> Displays the cumulative operation time of the cooling fan. The default value for the fan operation time is reset in parameter o4-03. This value will reset to 0 and start counting again after reaching 99999.	No signal output available	1 h	–
U4-04 (7EH)	Cooling Fan Maintenance	<b>All Modes</b> Displays main cooling fan usage time in as a percentage of its expected performance life. Parameter o4-03 can be used to reset this monitor.	No signal output available	1%	–
U4-05 (7CH)	Capacitor Maintenance	<b>All Modes</b> Displays main circuit capacitor usage time in as a percentage of their expected performance life. Parameter o4-05 can be used to reset this monitor.	No signal output available	1%	–
U4-06 (7D6H)	Soft Charge Bypass Relay Maintenance	<b>All Modes</b> Displays the soft charge bypass relay maintenance time as a percentage of its estimated performance life. Parameter o4-07 can be used to reset this monitor.	No signal output available	1%	–
U4-07 (7D7H)	IGBT Maintenance	<b>All Modes</b> Displays IGBT usage time as a percentage of the expected performance life. Parameter o4-09 can be used to reset this monitor.	No signal output available	1%	–
U4-08 (68H)	Heatsink Temperature	<b>All Modes</b> Displays the heatsink temperature.	10 V: 100°C	1°C	–
U4-09 (5EH)	LED Check	<b>All Modes</b> Lights all segments of the LED to verify that the display is working properly.	No signal output available	–	–
U4-10 (5CH)	kWh, Lower 4 Digits	<b>All Modes</b> Monitors the drive output power. The value is shown as a 9 digit number displayed across two monitor parameters, U4-10 and U4-11. Example: 12345678.9 kWh is displayed as: U4-10: 678.9 kWh U4-11: 12345 MWh	No signal output available	1 kWh	–
U4-11 (5DH)	kWh, Upper 5 Digits		No signal output available	1 MWh	–
U4-13 (7CFH)	Peak Hold Current	<b>All Modes</b> Displays the highest current value that occurred during run. <b>Note:</b> The unit is 1 A in models CIMR-E□4A0930 and 4A1200.	No signal output available	0.01 A <50> <19>	–
U4-14 (7D0H)	Peak Hold Output Frequency	<b>All Modes</b> Displays the output frequency when the current value shown in U4-13 occurred.	No signal output available	0.01 Hz	–
U4-16 (7D8H)	Motor Overload Estimate (oL1)	<b>All Modes</b> Shows the value of the motor overload detection accumulator. 100% is equal to the oL1 detection level.	10 V: 100%	0.1%	–
U4-18 (7DAH)	Frequency Reference Source Selection	<b>All Modes</b> Displays the source for the frequency reference as XY-nn. X: indicates which reference is used: 1 = Reference 1 (b1-01) 2 = Reference 2 (b1-15) Y-nn: indicates the reference source 0-01 = Digital operator 1-01 = Analog (terminal A1) 1-02 = Analog (terminal A2) 1-03 = Analog (terminal A3) 2-02 to 17 = Multi-step speed (d1-02 to 17) 3-01 = MEMOBUS/Modbus communications 4-01 = Communication option card 5-01 = Pulse input 7-01 = DWEZ	No signal output available	–	–
U4-19 (7DBH)	Frequency Reference from MEMOBUS/Modbus Comm.	<b>All Modes</b> Displays the frequency reference provided by MEMOBUS/Modbus (decimal).	No signal output available	0.01%	–
U4-20 (7DCH)	Option Frequency Reference	<b>All Modes</b> Displays the frequency reference input by an option card (decimal).	No signal output available	–	–

## B.3 Parameter Table

No. (Addr.)	Name	Description	Analog Output Level	Unit	Page
U4-21 (7DDH)	Run Command Source Selection	<p><b>All Modes</b></p> <p>Displays the source for the Run command as XY-nn.  X: Indicates which Run source is used:  1 = Reference 1 (b1-02)  2 = Reference 2 (b1-16)  Y: Input power supply data  0 = Digital operator  1 = External terminals  3 = MEMOBUS/Modbus communications  4 = Communication option card  7 = DWEZ  nn: Run command limit status data  00: No limit status.  01: Run command was left on when stopped in the PRG mode  02: Run command was left on when switching from LOCAL to REMOTE operation  03: Waiting for soft charge bypass contactor after power up (Uv or Uv1 flashes after 10 s)  04: Waiting for "Run command prohibited" time period to end  05: Fast Stop (digital input, digital operator)  06: b1-17 (Run command given at power-up)  07: During baseblock while coast to stop with timer  08: Frequency reference is below minimal reference during baseblock  09: Waiting for Enter command</p>	No signal output available	–	–
U4-22 (7DEH)	MEMOBUS/Modbus Communications Reference	<p><b>All Modes</b></p> <p>Displays the drive control data set by MEMOBUS/Modbus communications register no. 0001H as a four-digit hexadecimal number.</p>	No signal output available	–	–
U4-23 (7DFH)	Communication Option Card Reference	<p><b>All Modes</b></p> <p>Displays drive control data set by an option card as a four-digit hexadecimal number.</p>	No signal output available	–	–
U4-32 (7FBH)	Option Card Reference	<p><b>All Modes</b></p> <p>Displays the motor temperature (NTC).  U4-32 will display 20°C when a multi-function analog input is not set for motor thermistor input (H1-□□ = 17H).  <b>Note:</b> This parameter is available in models CIMR-E□4A0930 and 4A1200.</p>	200°C	1°C	–
U4-37 (1044H)	oH Alarm Location Monitor	<p><b>All Modes</b></p> <p>Displays the module where the oH alarm occurred as a binary number.  <b>Note:</b> This parameter is available in models CIMR-E□4A0930 and 4A1200.</p>	No signal output available	–	–
U4-38 (1045H)	FAn Alarm Location Monitor	<p><b>All Modes</b></p> <p>Displays the module where the FAn alarm occurred as a binary number.  <b>Note:</b> This parameter is available in models CIMR-E□4A0930 and 4A1200.</p>	No signal output available	–	–
U4-39 (1046H)	voF Alarm Location Monitor	<p><b>All Modes</b></p> <p>Displays the module where the voF alarm occurred as a binary number.  <b>Note:</b> This parameter is available in models CIMR-E□4A0930 and 4A1200.</p>	No signal output available	–	–

<19> This value's number of decimal places depends on the drive model. The value will have two decimal places (0.01 A) if the drive model is CIMR-E□2A0004 to 2A0040, 4A0002 to 4A0023 and one decimal place (0.1 A) if the drive model is CIMR-E□2A0056 to 2A0415, 4A0031 to 4A1200.

<50> When reading the value of this monitor via MEMOBUS/Modbus a value of 8192 is equal to 100% of the drive rated output current.

### ■ U5: PI Monitors

No. (Addr.)	Name	Description	Analog Output Level	Unit	Page
U5-01 (57H)	PI Feedback	<p><b>All Modes</b></p> <p>Displays the PI feedback value.</p>	10 V: 100%	0.01%	–
U5-02 (63H)	PI Input	<p><b>All Modes</b></p> <p>Displays the amount of PI input (deviation between PI setpoint and feedback).</p>	10 V: 100%	0.01%	–
U5-03 (64H)	PI Output	<p><b>All Modes</b></p> <p>Displays PI control output.</p>	10 V: 100%	0.01%	–
U5-04 (65H)	PI Setpoint	<p><b>All Modes</b></p> <p>Displays the PI setpoint.</p>	10 V: 100%	0.01%	–
U5-05 (7D2H)	PI Differential Feedback	<p><b>All Modes</b></p> <p>Displays the 2nd PI feedback value if differential feedback is used (H3-□□ = 16).</p>	10 V: 100%	0.01%	–
U5-06 (7D3H)	PI Adjusted Feedback	<p><b>All Modes</b></p> <p>Displays the difference of both feedback values if differential feedback is used (U5-01 - U5-05).  If differential feedback is not used, then U5-01 and U5-06 will be the same.</p>	10 V: 100%	0.01%	–
U5-14 (86BH)	PI Output Upper 4 Digits	<p><b>All Modes</b></p> <p>Displays Custom PI output. U5-14 shows the upper 4 digits.</p>	No signal output available	–	–
U5-15 (86CH)	PI Output Lower 4 Digits	<p><b>All Modes</b></p> <p>Displays Custom PI output. U5-15 shows the lower 4 digits.</p>	No signal output available	–	–

## ■ U6: Operation Status Monitors

No. (Addr.)	Name	Description	Analog Output Level	Unit	Page
U6-01 (51H)	Motor Secondary Current (Iq)	<b>All Modes</b> Displays the value of the motor secondary current (Iq). Motor rated secondary current is 100%.	10 V: Motor secondary rated current	0.1%	–
U6-02 (52H)	Motor Excitation Current (Id)	<b>V/f</b> <b>OLV/PM</b> Displays the value calculated for the motor excitation current (Id). Motor rated secondary current is 100%.	10 V: Motor secondary rated current	0.1%	–
U6-05 (59H)	Output Voltage Reference (Vq)	<b>V/f</b> <b>OLV/PM</b> Output voltage reference (Vq) for the q-axis.	10 V: 200 Vrms <18>	0.1 Vac	–
U6-06 (5AH)	Output Voltage Reference (Vd)	<b>V/f</b> <b>OLV/PM</b> Output voltage reference (Vd) for the d-axis.	10 V: 200 Vrms <18>	0.1 Vac	–
U6-21 (7D5H)	Offset Frequency	<b>All Modes</b> Displays the frequency added to the main frequency reference.	–	0.1%	–

<18> Values shown here are for 200 V class drives. Double the value when using a 400 V class drive.

## ■ U8: DriveWorksEZ Monitors

No. (Addr.)	Name	Description	Analog Output Level	Unit	Page
U8-01 to U8-10 (1950H to 1959H)	DriveWorksEZ Custom Monitor 1 to 10	<b>All Modes</b> DriveWorksEZ Custom Monitor 1 to 10	10 V: 100%	0.01%	–
U8-11 to U8-13 (195AH to 195CH)	DriveWorksEZ Version Control Monitor 1 to 3	<b>All Modes</b> DriveWorksEZ Version Control Monitor 1 to 3	No signal output available	–	–

## B.4 Control Mode Dependent Parameter Default Values

The tables below list parameters that depend on the control mode selection. These parameters are initialized to the shown values if the control mode is changed.

### ◆ A1-02 Dependent Parameters

Table B.2 A1-02 Dependent Parameters and Default Values

No.	Name	Setting Range	Resolution	Control Modes (A1-02)	
				V/f (0)	OLV/PM (5)
b2-01	DC Injection Braking Start Frequency	0.0 to 10.0	0.1	0.5 Hz	0.5 Hz
b2-04	DC Injection Braking Time at Stop	0.00 to 10.00	0.01 s	0.50	0.00
b3-01	Speed Search Selection at Start	0 to 1	–	0	0
b3-02	Speed Search Deactivation Current	0 to 200	1%	120	–
b3-14	Bi-Directional Speed Search Selection	0 to 1	1	1	1
b5-15	PID Sleep Function Start Level	0.0 to 200.0	0.1	0.0 Hz	0.0 Hz
b8-01	Energy Saving Control Selection	0 to 1	–	0	–
C1-11	Accel/Decel Time Switching Frequency	0.0 to 200.0	0.1	0.0 Hz	0.0 Hz
C2-01	S-Curve Time at Acceleration Start	0.00 to 10.00	0.01 s	0.20	1.00
C4-01	Torque Compensation Gain	0.00 to 2.50	0.01	1.00	0.00
C4-02	Torque Compensation Primary Delay Time	0 to 10000	1 ms	200 <53>	100
C6-02	Carrier Frequency Selection	1 to F	–	0.0 Hz	0.0 Hz
d3-01	Jump Frequency 1	0.0 to 200.0	0.1	0.0 Hz	0.0 Hz
d3-02	Jump Frequency 2	0.0 to 200.0	0.1	0.0 Hz	0.0 Hz
d3-03	Jump Frequency 3	0.0 to 200.0	0.1	0.0 Hz	0.0 Hz
d3-04	Jump Frequency Width	0.0 to 20.0	0.1	1.0 Hz	1.0 Hz
E1-04	Maximum Output Frequency	40.0 to 200.0	0.1 Hz	60.0	<14>
E1-05	Maximum Voltage <18>	0.0 to 255.0	0.1 V	200.0 <52>	<14>
E1-06	Base Frequency	0.0 to 400.0	0.1 Hz	50.0 <52>	<14>
E1-07	Middle Output Frequency	0.0 to 200.0	0.1 Hz	3.0 <52>	–
E1-08	Middle Output Frequency Voltage <18>	0.0 to 255.0	0.1 V	15.0 <52>	–
E1-09	Minimum Output Frequency	0.0 to 200.0	0.1 Hz	1.5 <52>	<14>
E1-10	Minimum Output Frequency Voltage <18>	0.0 to 255.0	0.1 V	9.0	–
L1-01	Motor Overload Protection Selection	0 to 4	–	1	4
L3-20	DC Bus Voltage Adjustment Gain	0.00 to 5.00	0.01	1.00	0.65
L3-21	Accel/Decel Rate Calculation Gain	0.00 to 200.00	0.01	1.00	2.50
L4-01	Speed Agreement Detection Level	0.0 to 200.0	0.1	0.0 Hz	0.0 Hz
L4-02	Speed Agreement Detection Width	0.0 to 20.0	0.1	2.0 Hz	2.0Hz
L4-03	Speed Agreement Detection Level (+/-)	-200.0 to 200.0	0.1	0.0 Hz	0.0 Hz
L4-04	Speed Agreement Detection Width (+/-)	0.0 to 20.0	0.1	2.0 Hz	2.0Hz
L8-38	Carrier Frequency Reduction Selection	0 to 2	1	<9>	0
L8-40	Carrier Frequency Reduction Off Delay Time	0.00 to 2.00	0.01 s	0.50	0.00
o1-03	Digital Operator Display Selection	0 to 3	1	0	0

<9> Default setting is determined by the drive model (o2-04).

<14> Default setting value is dependent on the motor code set to parameter E5-01.

<18> Values shown here are for 200 V class drives. Double the value when using a 400 V class drive.

<52> This setting value depends on a Maximum Applicable Motor Capacity and V/f pattern selection in parameter E1-03.

<53> This setting value depends on a Maximum Applicable Motor Capacity: 1000 s in models CIMR-E□2A0110 to 2A0415 and CIMR-E□4A0103 to 4A1200.

## B.5 V/f Pattern Default Values

The tables below show the V/f pattern settings default values depending on the control mode (A1-02) and the V/f pattern selection (E1-03 in V/f Control).

**Table B.3 E1-03 V/f Pattern Settings for Drive Capacity:  
CIMR-E□2A0004 to 2A0021, CIMR-E□4A0002 to 4A0011**

No.	Units	V/f																OLV/PM
		0	1	2	3	4	5	6	7	8	9	A	B	C	D	E	F <42>	
E1-03	-	0	1	2	3	4	5	6	7	8	9	A	B	C	D	E	F <42>	OLV/PM
E1-04	Hz	50.0	60.0	60.0	72.0	50.0	50.0	60.0	60.0	50.0	50.0	60.0	60.0	90.0	120.0	180.0	50.0	<14>
E1-05 <18>	V	200.0	200.0	200.0	200.0	200.0	200.0	200.0	200.0	200.0	200.0	200.0	200.0	200.0	200.0	200.0	200.0	<14>
E1-06	Hz	50.0	60.0	50.0	60.0	50.0	50.0	60.0	60.0	50.0	50.0	60.0	60.0	60.0	60.0	60.0	50.0	<14>
E1-07	Hz	2.5	3.0	3.0	3.0	25.0	25.0	30.0	30.0	2.5	2.5	3.0	3.0	3.0	3.0	3.0	2.5	-
E1-08 <18>	V	15.0	15.0	15.0	15.0	35.0	50.0	35.0	50.0	19.0	24.0	19.0	24.0	15.0	15.0	15.0	15.0	-
E1-09	Hz	1.3	1.5	1.5	1.5	1.3	1.3	1.5	1.5	1.3	1.3	1.5	1.5	1.5	1.5	1.5	1.3	<14>
E1-10 <18>	V	9.0	9.0	9.0	9.0	8.0	9.0	8.0	9.0	11.0	13.0	11.0	15.0	9.0	9.0	9.0	9.0	-

<14> Default setting value is dependent on the motor code set to parameter E5-01.  
 <18> Values shown here are for 200 V class drives. Double the value when using a 400 V class drive.  
 <42> Default settings for E1-04 through E1-10.

**Table B.4 E1-03 V/f Pattern Settings for Drive Capacity:  
CIMR-E□2A0030 to 2A0211, CIMR-E□4A0018 to 4A0103**

No.	Units	V/f																OLV/PM
		0	1	2	3	4	5	6	7	8	9	A	B	C	D	E	F <42>	
E1-03	-	0	1	2	3	4	5	6	7	8	9	A	B	C	D	E	F <42>	OLV/PM
E1-04	Hz	50.0	60.0	60.0	72.0	50.0	50.0	60.0	60.0	50.0	50.0	60.0	60.0	90.0	120.0	180.0	50.0	<14>
E1-05 <18>	V	200.0	200.0	200.0	200.0	200.0	200.0	200.0	200.0	200.0	200.0	200.0	200.0	200.0	200.0	200.0	200.0	<14>
E1-06	Hz	50.0	60.0	50.0	60.0	50.0	50.0	60.0	60.0	50.0	50.0	60.0	60.0	60.0	60.0	60.0	50.0	<14>
E1-07	Hz	2.5	3.0	3.0	3.0	25.0	25.0	30.0	30.0	2.5	2.5	3.0	3.0	3.0	3.0	3.0	2.5	-
E1-08 <18>	V	14.0	14.0	14.0	14.0	35.0	50.0	35.0	50.0	18.0	23.0	18.0	23.0	14.0	14.0	14.0	14.0	-
E1-09	Hz	1.3	1.5	1.5	1.5	1.3	1.3	1.5	1.5	1.3	1.3	1.5	1.5	1.5	1.5	1.5	1.3	<14>
E1-10 <18>	V	7.0	7.0	7.0	7.0	6.0	7.0	6.0	7.0	9.0	11.0	9.0	13.0	7.0	7.0	7.0	7.0	-

<14> Default setting value is dependent on the motor code set to parameter E5-01.  
 <18> Values shown here are for 200 V class drives. Double the value when using a 400 V class drive.  
 <42> Default settings for E1-04 through E1-10.

**Table B.5 E1-03 V/f Pattern Settings for Drive Capacity:  
CIMR-E□2A0250 to 2A0415, CIMR-E□4A0139 to 4A1200**

No.	Units	V/f																OLV/PM
		0	1	2	3	4	5	6	7	8	9	A	B	C	D	E	F <42>	
E1-03	-	0	1	2	3	4	5	6	7	8	9	A	B	C	D	E	F <42>	OLV/PM
E1-04	Hz	50.0	60.0	60.0	72.0	50.0	50.0	60.0	60.0	50.0	50.0	60.0	60.0	90.0	120.0	180.0	50.0	<14>
E1-05 <18>	V	200.0	200.0	200.0	200.0	200.0	200.0	200.0	200.0	200.0	200.0	200.0	200.0	200.0	200.0	200.0	200.0	<14>
E1-06	Hz	50.0	60.0	50.0	60.0	50.0	50.0	60.0	60.0	50.0	50.0	60.0	60.0	60.0	60.0	60.0	50.0	<14>
E1-07	Hz	2.5	3.0	3.0	3.0	25.0	25.0	30.0	30.0	2.5	2.5	3.0	3.0	3.0	3.0	3.0	2.5	-
E1-08 <18>	V	12.0	12.0	12.0	12.0	35.0	50.0	35.0	50.0	15.0	20.0	15.0	20.0	12.0	12.0	12.0	12.0	-
E1-09	Hz	1.3	1.5	1.5	1.5	1.3	1.3	1.5	1.5	1.3	1.3	1.5	1.5	1.5	1.5	1.5	1.3	<14>
E1-10 <18>	V	6.0	6.0	6.0	6.0	5.0	6.0	5.0	6.0	7.0	9.0	7.0	11.0	6.0	6.0	6.0	6.0	-

<14> Default setting value is dependent on the motor code set to parameter E5-01.  
 <18> Values shown here are for 200 V class drives. Double the value when using a 400 V class drive.  
 <42> Default settings for E1-04 through E1-10.

## B.6 Defaults by Drive Model Selection (o2-04)

The following tables show parameters and default settings that change with the drive model selection (o2-04).

**Table B.6 200 V Class Drives Default Settings by Drive Model Selection**

No.	Name	Unit	Default Settings						
			2A0004	2A0006	2A0008	2A0010	2A0012	2A0018	2A0021
<b>Model CIMR-E□</b>			–						
<b>o2-04</b>	<b>Drive Model Selection</b>	<b>Hex.</b>	<b>62</b>	<b>63</b>	<b>64</b>	<b>65</b>	<b>66</b>	<b>67</b>	<b>68</b>
<b>E2-11</b>	<b>Motor rated Output</b>	<b>kW</b>	<b>0.75</b>	<b>1.1</b>	<b>1.5</b>	<b>2.2</b>	<b>3.0</b>	<b>3.7</b>	<b>5.5</b>
b3-04	V/f Gain during Speed Search	%	100	100	100	100	100	100	100
b3-06	Output Current 1 during Speed Search	–	1	0.5	0.5	0.5	0.5	0.5	0.5
b8-04	Energy Saving Coefficient Value	–	223.7	196.6	169.4	156.8	136.4	122.9	94.75
C6-02	Carrier Frequency Selection	–	7	7	7	7	7	7	7
E2-01	Motor Rated Current	A	3.3	4.9	6.2	8.5	11.4	14	19.6
E2-02	Motor Rated Slip	Hz	2.5	2.6	2.6	2.9	2.7	2.73	1.5
E2-03	Motor No-Load Current	A	1.8	2.3	2.8	3	3.7	4.5	5.1
E2-05	Motor Line to Line Resistance	Ω	5.156	3.577	1.997	1.601	1.034	0.771	0.399
E2-06	Motor Leakage Inductance	%	13.8	18.5	18.5	18.4	19	19.6	18.2
E2-10	Motor Iron Loss for Torque Compensation	W	26	38	53	77	91	112	172
E5-01	Motor Code Selection	Hex.	1202	1203	FFFF	1205	1206	FFFF	1208
L2-02	Momentary Power Loss Ride-Thru Time	s	0.1	0.2	0.3	0.3	0.5	1	1
L2-03	Momentary Power Loss Minimum Baseblock Time	s	0.3	0.4	0.4	0.5	0.5	0.6	0.7
L2-04	Momentary Power Loss Voltage Recovery Time	s	0.3	0.3	0.3	0.3	0.3	0.3	0.3
L3-24	Motor Acceleration Time for Inertia Calculations	s	0.142	0.142	0.166	0.145	0.145	0.154	0.168
L8-02	Overheat Alarm Level	°C	115	115	115	115	125	110	110
L8-35	Installation Method Selection	–	2	2	2	2	2	2	2
n1-03	Hunting Prevention Time Constant	ms	10	10	10	10	10	10	10

No.	Name	Unit	Default Settings						
			2A0030	2A0040	2A0056	2A0069	2A0081	2A0110	2A0138
<b>Model CIMR-E□</b>			–						
<b>o2-04</b>	<b>Drive Model Selection</b>	<b>Hex.</b>	<b>6A</b>	<b>6B</b>	<b>6D</b>	<b>6E</b>	<b>6F</b>	<b>70</b>	<b>72</b>
<b>E2-11</b>	<b>Motor rated Output</b>	<b>kW</b>	<b>7.5</b>	<b>11</b>	<b>15</b>	<b>18.5</b>	<b>22</b>	<b>30</b>	<b>37</b>
b3-04	V/f Gain during Speed Search	%	100	100	100	100	100	80	80
b3-06	Output Current 1 during Speed Search	–	0.5	0.5	0.5	0.5	0.5	0.5	0.5
b8-04	Energy Saving Coefficient Value	–	72.69	70.44	63.13	57.87	51.79	46.27	38.16
C6-02	Carrier Frequency Selection	–	7	7	7	7	7	7	7
E2-01	Motor Rated Current	A	26.6	39.7	53	65.8	77.2	105	131
E2-02	Motor Rated Slip	Hz	1.3	1.7	1.6	1.67	1.7	1.8	1.33
E2-03	Motor No-Load Current	A	8	11.2	15.2	15.7	18.5	21.9	38.2
E2-05	Motor Line to Line Resistance	Ω	0.288	0.23	0.138	0.101	0.079	0.064	0.039
E2-06	Motor Leakage Inductance	%	15.5	19.5	17.2	15.7	19.5	20.8	18.8
E2-10	Motor Iron Loss for Torque Compensation	W	262	245	272	505	538	699	823
E5-01	Motor Code Selection	Hex.	120A	120B	120D	120E	120F	1210	1212
L2-02	Momentary Power Loss Ride-Thru Time	s	1	1	2	2	2	2	2
L2-03	Momentary Power Loss Minimum Baseblock Time	s	0.8	0.9	1	1	1	1.1	1.1
L2-04	Momentary Power Loss Voltage Recovery Time	s	0.3	0.3	0.6	0.6	0.6	0.6	0.6
L3-24	Motor Acceleration Time for Inertia Calculations	s	0.175	0.265	0.244	0.317	0.355	0.323	0.32
L8-02	Overheat Alarm Level	°C	120	125	120	120	125	130	130
L8-35	Installation Method Selection	–	2	2	2	2	2	0	0
n1-03	Hunting Prevention Time Constant	ms	10	10	10	10	10	10	10



No.	Name	Unit	Default Settings					
			2A0169	2A0211	2A0250	2A0312	2A0360	2A0415
<b>Model CIMR-E□</b>		–						
<b>o2-04</b>	<b>Drive Model Selection</b>	<b>Hex.</b>	<b>73</b>	<b>74</b>	<b>75</b>	<b>76</b>	<b>77</b>	<b>78</b>
<b>E2-11</b>	<b>Motor rated Output</b>	<b>kW</b>	<b>45</b>	<b>55</b>	<b>75</b>	<b>90</b>	<b>110</b>	<b>110</b>
b3-04	V/f Gain during Speed Search	%	80	80	80	80	80	80
b3-06	Output Current I during Speed Search	–	0.5	0.5	0.7	0.7	0.7	0.7
b8-04	Energy Saving Coefficient Value	–	35.78	31.35	23.1	20.65	18.12	18.12
C6-02	Carrier Frequency Selection	–	7	7	7	7	7	7
E2-01	Motor Rated Current	A	160	190	260	260	260	260
E2-02	Motor Rated Slip	Hz	1.6	1.43	1.39	1.39	1.39	1.39
E2-03	Motor No-Load Current	A	44	45.6	72	72	72	72
E2-05	Motor Line to Line Resistance	Ω	0.03	0.022	0.023	0.023	0.023	0.023
E2-06	Motor Leakage Inductance	%	20.2	20.5	20	20	20	20
E2-10	Motor Iron Loss for Torque Compensation	W	852	960	1200	1200	1200	1200
E5-01	Motor Code Selection	Hex.	1213	1214	1215	1216	FFFF	FFFF
L2-02	Momentary Power Loss Ride-Thru Time	s	2	2	2	2	2	2
L2-03	Momentary Power Loss Minimum Baseblock Time	s	1.2	1.3	1.5	1.5	1.7	1.7
L2-04	Momentary Power Loss Voltage Recovery Time	s	1	1	1	1	1	1
L3-24	Motor Acceleration Time for Inertia Calculations	s	0.387	0.317	0.533	0.592	0.646	0.646
L8-02	Overheat Alarm Level	°C	130	125	115	120	120	120
L8-35	Installation Method Selection	–	0	0	0	0	0	0
n1-03	Hunting Prevention Time Constant	ms	10	10	10	10	100	100

**Table B.7 400 V Class Drives Default Settings by Drive Capacity**

No.	Name	Unit	Default Settings						
			4A0002	4A0004	4A0005	4A0007	4A0009	4A0011	4A0018
<b>Model CIMR-E□</b>		–							
<b>o2-04</b>	<b>Drive Model Selection</b>	<b>Hex.</b>	<b>92</b>	<b>93</b>	<b>94</b>	<b>95</b>	<b>96</b>	<b>97</b>	<b>99</b>
<b>E2-11</b>	<b>Motor rated Output</b>	<b>kW</b>	<b>0.75</b>	<b>1.5</b>	<b>2.2</b>	<b>3.0</b>	<b>3.7</b>	<b>5.5</b>	<b>7.5</b>
b3-04	V/f Gain during Speed Search	%	100	100	100	100	100	100	100
b3-06	Output Current I during Speed Search	–	0.5	0.5	0.5	0.5	0.5	0.5	0.5
b8-04	Energy Saving Coefficient Value	–	447.4	338.8	313.6	265.7	245.8	189.5	145.38
C6-02	Carrier Frequency Selection	–	7	7	7	7	7	7	7
E2-01	Motor Rated Current	A	1.6	3.1	4.2	5.7	7	9.8	13.3
E2-02	Motor Rated Slip	Hz	2.6	2.5	3	2.7	2.7	1.5	1.3
E2-03	Motor No-Load Current	A	0.8	1.4	1.5	1.9	2.3	2.6	4
E2-05	Motor Line to Line Resistance	Ω	22.459	10.1	6.495	4.360	3.333	1.595	1.152
E2-06	Motor Leakage Inductance	%	14.3	18.3	18.7	19	19.3	18.2	15.5
E2-10	Motor Iron Loss for Torque Compensation	W	26	53	77	105	130	193	263
E5-01	Motor Code Selection	Hex.	1232	1233	1235	1236	FFFF	1238	123A
L2-02	Momentary Power Loss Ride-Thru Time	s	0.1	0.2	0.3	0.5	0.5	0.5	0.8
L2-03	Momentary Power Loss Minimum Baseblock Time	s	0.3	0.4	0.5	0.5	0.6	0.7	0.8
L2-04	Momentary Power Loss Voltage Recovery Time	s	0.3	0.3	0.3	0.3	0.3	0.3	0.3
L3-24	Motor Acceleration Time for Inertia Calculations	s	0.142	0.166	0.145	0.145	0.154	0.168	0.175
L8-02	Overheat Alarm Level	°C	110	110	110	110	110	110	110
L8-35	Installation Method Selection	–	2	2	2	2	2	2	2
n1-03	Hunting Prevention Time Constant	ms	10	10	10	10	10	10	10

## B.6 Defaults by Drive Model Selection (o2-04)

No.	Name	Unit	Default Settings						
			4A0023	4A0031	4A0038	4A0044	4A0058	4A0072	4A0088
<b>Model CIMR-E□</b>			–						
<b>o2-04</b>	<b>Drive Model Selection</b>	<b>Hex.</b>	<b>9A</b>	<b>9C</b>	<b>9D</b>	<b>9E</b>	<b>9F</b>	<b>A1</b>	<b>A2</b>
<b>E2-11</b>	<b>Motor rated Output</b>	<b>kW</b>	<b>11</b>	<b>15</b>	<b>18.5</b>	<b>22</b>	<b>30</b>	<b>37</b>	<b>45</b>
b3-04	V/f Gain during Speed Search	%	100	100	100	100	100	100	100
b3-06	Output Current 1 during Speed Search	–	0.5	0.5	0.5	0.5	0.5	0.5	0.5
b8-04	Energy Saving Coefficient Value	–	140.88	126.26	115.74	103.58	92.54	76.32	71.56
C6-02	Carrier Frequency Selection	–	7	7	7	7	7	7	7
E2-01	Motor Rated Current	A	19.9	26.5	32.9	38.6	52.3	65.6	79.7
E2-02	Motor Rated Slip	Hz	1.7	1.6	1.67	1.7	1.8	1.33	1.6
E2-03	Motor No-Load Current	A	5.6	7.6	7.8	9.2	10.9	19.1	22
E2-05	Motor Line to Line Resistance	Ω	0.922	0.55	0.403	0.316	0.269	0.155	0.122
E2-06	Motor Leakage Inductance	%	19.6	17.2	20.1	23.5	20.7	18.8	19.9
E2-10	Motor Iron Loss for Torque Compensation	W	385	440	508	586	750	925	1125
E5-01	Motor Code Selection	Hex.	123B	123D	123E	123F	1240	1242	1243
L2-02	Momentary Power Loss Ride-Thru Time	s	1	2	2	2	2	2	2
L2-03	Momentary Power Loss Minimum Baseblock Time	s	0.9	1	1	1	1.1	1.1	1.2
L2-04	Momentary Power Loss Voltage Recovery Time	s	0.3	0.6	0.6	0.6	0.6	0.6	0.6
L3-24	Motor Acceleration Time for Inertia Calculations	s	0.265	0.244	0.317	0.355	0.323	0.32	0.387
L8-02	Overheat Alarm Level	°C	115	120	120	115	120	120	110
L8-35	Installation Method Selection	–	2	2	2	2	0	0	0
n1-03	Hunting Prevention Time Constant	ms	10	10	10	10	10	10	10

No.	Name	Unit	Default Settings						
			4A0103	4A0139	4A0165	4A0208	4A0250	4A0296	4A0362
<b>Model CIMR-E□</b>			–						
<b>o2-04</b>	<b>Drive Model Selection</b>	<b>Hex.</b>	<b>A3</b>	<b>A4</b>	<b>A5</b>	<b>A6</b>	<b>A7</b>	<b>A8</b>	<b>A9</b>
<b>E2-11</b>	<b>Motor rated Output</b>	<b>kW</b>	<b>55</b>	<b>75</b>	<b>90</b>	<b>110</b>	<b>132</b>	<b>160</b>	<b>185</b>
b3-04	V/f Gain during Speed Search	%	80	60	60	60	60	60	60
b3-06	Output Current 1 during Speed Search	–	0.5	0.7	0.7	0.7	0.7	0.7	0.7
b8-04	Energy Saving Coefficient Value	–	67.2	46.2	38.91	36.23	32.79	30.13	30.57
C6-02	Carrier Frequency Selection	–	7	7	7	7	7	7	7
E2-01	Motor Rated Current	A	95	130	156	190	223	270	310
E2-02	Motor Rated Slip	Hz	1.46	1.39	1.4	1.4	1.38	1.35	1.3
E2-03	Motor No-Load Current	A	24	36	40	49	58	70	81
E2-05	Motor Line to Line Resistance	Ω	0.088	0.092	0.056	0.046	0.035	0.029	0.025
E2-06	Motor Leakage Inductance	%	20	20	20	20	20	20	20
E2-10	Motor Iron Loss for Torque Compensation	W	1260	1600	1760	2150	2350	2850	3200
E5-01	Motor Code Selection	Hex.	1244	1245	1246	1247	1248	1249	124A
L2-02	Momentary Power Loss Ride-Thru Time	s	2	2	2	2	2	2	2
L2-03	Momentary Power Loss Minimum Baseblock Time	s	1.2	1.3	1.5	1.7	1.7	1.8	1.9
L2-04	Momentary Power Loss Voltage Recovery Time	s	1	1	1	1	1	1	1
L3-24	Motor Acceleration Time for Inertia Calculations	s	0.317	0.533	0.592	0.646	0.673	0.777	0.864
L8-02	Overheat Alarm Level	°C	120	130	130	120	120	125	130
L8-35	Installation Method Selection	–	0	0	0	0	0	0	0
n1-03	Hunting Prevention Time Constant	ms	10	30	30	30	30	30	30

## B.6 Defaults by Drive Model Selection (o2-04)

No.	Name	Unit	Default Settings				
			4A0414	4A0515	4A0675	4A0930	4A1200
	<b>Model CIMR-E□</b>	–					
<b>o2-04</b>	<b>Drive Model Selection</b>	Hex.	<b>AA</b>	<b>AC</b>	<b>AE</b>	<b>B0</b>	<b>B2</b>
<b>E2-11</b>	<b>Motor rated Output</b>	kW	<b>220</b>	<b>250</b>	<b>355</b>	<b>500</b>	<b>630</b>
b3-04	V/f Gain during Speed Search	%	60	60	60	60	60
b3-06	Output Current I during Speed Search	–	0.7	0.7	0.7	0.7	0.7
b8-04	Energy Saving Coefficient Value	–	27.13	21.76	23.84	20.26	17.06
C6-02	Carrier Frequency Selection	–	7	7	7	7	7
E2-01	Motor Rated Current	A	370	500	650	900	1200
E2-02	Motor Rated Slip	Hz	1.3	1.25	1	0.9	0.7
E2-03	Motor No-Load Current	A	96	130	130	180	240
E2-05	Motor Line to Line Resistance	Ω	0.02	0.014	0.012	0.009	0.006
E2-06	Motor Leakage Inductance	%	20	20	20	20	20
E2-10	Motor Iron Loss for Torque Compensation	W	3700	4700	5560	7833	11123
E5-01	Motor Code Selection	Hex.	FFFF	FFFF	FFFF	FFFF	FFFF
L2-02	Momentary Power Loss Ride-Thru Time	s	2	2	2	2	2
L2-03	Momentary Power Loss Minimum Baseblock Time	s	2	2.1	2.3	3.1	4.6
L2-04	Momentary Power Loss Voltage Recovery Time	s	1	1	1	3	4.5
L3-24	Motor Acceleration Time for Inertia Calculations	s	0.91	1.392	1.667	2.222	3.333
L8-02	Overheat Alarm Level	°C	140	140	140	140	140
L8-35	Installation Method Selection	–	0	0	0	0	0
n1-03	Hunting Prevention Time Constant	ms	100	100	100	100	100

## B.7 Parameters that Change with the Motor Code Selection

The following tables show parameters and default settings that change with the motor code selection E5-01 when Open Loop Vector for PM motors is used.

### ◆ YASKAWA SMRA Series SPM Motor

Table B.8 200 V, 1800 r/min Type YASKAWA SMRA Series SPM Motor

No.	Name	Unit	Default Settings				
E5-01	Motor Code Selection	–	0002	0003	0005	0006	0008
	Voltage Class	V	200	200	200	200	200
	Rated Power	kW	0.4	0.75	1.5	2.2	3.7
	Rated Speed	r/min	1800	1800	1800	1800	1800
E5-02	Motor Rated Power	kW	0.4	0.75	1.5	2.2	3.7
E5-03	Motor Rated Current	A	2.1	4.0	6.9	10.8	17.4
E5-04	Number of Motor Poles	–	8	8	8	8	8
E5-05	Motor Stator Resistance (r1)	Ω	2.47	1.02	0.679	0.291	0.169
E5-06	Motor d-Axis Inductance (Ld)	mH	12.7	4.8	3.9	3.6	2.5
E5-07	Motor q-Axis Inductance (Lq)	mH	12.7	4.8	3.9	3.6	2.5
E5-09	Motor Induction Voltage Constant 1 (Ke)	mVs/rad	0	0	0	0	0
E5-24	Motor Induction Voltage Constant 2 (Ke)	mV/(r/min)	62.0	64.1	73.4	69.6	72.2
E1-04	Maximum Output Frequency	Hz	120	120	120	120	120
E1-05	Maximum Voltage	V	200.0	200.0	200.0	200.0	200.0
E1-06	Base Frequency	Hz	120	120	120	120	120
E1-09	Minimum Output Frequency	Hz	6	6	6	6	6
L3-24	Motor Acceleration Time for Inertia Calculations	s	0.064	0.066	0.049	0.051	0.044
n8-49	d-Axis Current for High Efficiency Control (OLV/PM)	%	0	0	0	0	0

Table B.9 200 V, 3600 r/min Type YASKAWA SMRA Series SPM Motor

No.	Name	Unit	Default Settings			
E5-01	Motor Code Selection	–	0103	0105	0106	0108
	Voltage Class	V	200	200	200	200
	Rated Power	kW	0.75	1.5	2.2	3.7
	Rated Speed	r/min	3600	3600	3600	3600
E5-02	Motor Rated Power	kW	0.75	1.5	2.2	3.7
E5-03	Motor Rated Current	A	4.1	8.0	10.5	16.5
E5-04	Number of Motor Poles	–	8	8	8	8
E5-05	Motor Stator Resistance (r1)	Ω	0.538	0.20	0.15	0.097
E5-06	Motor d-Axis Inductance (Ld)	mH	3.2	1.3	1.1	1.1
E5-07	Motor q-Axis Inductance (Lq)	mH	3.2	1.3	1.1	1.1
E5-09	Motor Induction Voltage Constant 1 (Ke)	mVs/rad	0	0	0	0
E5-24	Motor Induction Voltage Constant 2 (Ke)	mV/(r/min)	32.4	32.7	36.7	39.7
E1-04	Maximum Output Frequency	Hz	240	240	240	240
E1-05	Maximum Voltage	V	200.0	200.0	200.0	200.0
E1-06	Base Frequency	Hz	240	240	240	240
E1-09	Minimum Output Frequency	Hz	12	12	12	12
L3-24	Motor Acceleration Time for Inertia Calculations	s	0.137	0.132	0.132	0.122
n8-49	d-Axis Current for High Efficiency Control (OLV/PM)	%	0	0	0	0

◆ YASKAWA SSR1 Series IPM Motor (For Derated Torque)

Table B.10 200 V, 1750 r/min Type YASKAWA SSR1 Series IPM Motor

No.	Name	Unit	Default Settings							
E5-01	Motor Code Selection	–	1202	1203	1205	1206	1208	120A	120B	120D
	Voltage Class	V	200	200	200	200	200	200	200	200
	Rated Power	kW	0.4kW	0.75	1.5	2.2	3.7	5.5	7.5	11
	Rated Speed	r/min	1750	1750	1750	1750	1750	1750	1750	1750
E5-02	Motor Rated Power	kW	0.4	0.75	1.5	2.2	3.7	5.5	7.5	11.0
E5-03	Motor Rated Current	A	1.77	3.13	5.73	8.44	13.96	20.63	28.13	41.4
E5-04	Number of Motor Poles	–	6	6	6	6	6	6	6	6
E5-05	Motor Stator Resistance (r1)	Ω	8.233	2.284	1.470	0.827	0.455	0.246	0.198	0.094
E5-06	Motor d-Axis Inductance (Ld)	mH	54.84	23.02	17.22	8.61	7.20	4.86	4.15	3.40
E5-07	Motor q-Axis Inductance (Lq)	mH	64.10	29.89	20.41	13.50	10.02	7.43	5.91	3.91
E5-09	Motor Induction Voltage Constant 1 (Ke)	mVs/rad	223.7	220.3	240.8	238.0	238.7	239.6	258.2	239.3
E5-24	Motor Induction Voltage Constant 2 (Ke)	mV/(r/min)	0.0	0.0	0.0	0.0	0.0	0.0	0.0	0.0
E1-04	Maximum Output Frequency	Hz	87.5	87.5	87.5	87.5	87.5	87.5	87.5	87.5
E1-05	Maximum Voltage	V	190.0	190.0	190.0	190.0	190.0	190.0	190.0	190.0
E1-06	Base Frequency	Hz	87.5	87.5	87.5	87.5	87.5	87.5	87.5	87.5
E1-09	Minimum Output Frequency	Hz	4.4	4.4	4.4	4.4	4.4	4.4	4.4	4.4
L3-24	Motor Acceleration Time for Inertia Calculations	s	0.092	0.076	0.052	0.066	0.075	0.083	0.077	0.084
n8-49	d-Axis Current for High Efficiency Control (OLV/PM)	%	-7.6	-11.5	-9.1	-19.0	-18.7	-23.4	-18.5	-10.9

No.	Name	Unit	Default Settings							
E5-01	Motor Code Selection	–	120E	120F	1210	1212	1213	1214	1215	1216
	Voltage Class	V	200	200	200	200	200	200	200	200
	Rated Power	kW	15	18	22	30	37	45	55	75
	Rated Speed	r/min	1750	1750	1750	1750	1750	1750	1750	1750
E5-02	Motor Rated Power	kW	15.00	18.50	22.00	30.00	37.00	45.00	55.00	75.00
E5-03	Motor Rated Current	A	55.4	68.2	80.6	105.2	131.3	153.1	185.4	257.3
E5-04	Number of Motor Poles	–	6	6	6	6	6	6	6	6
E5-05	Motor Stator Resistance (r1)	Ω	0.066	0.051	0.037	0.030	0.020	0.014	0.012	0.006
E5-06	Motor d-Axis Inductance (Ld)	mH	2.45	2.18	1.71	1.35	0.99	0.83	0.79	0.44
E5-07	Motor q-Axis Inductance (Lq)	mH	3.11	2.55	2.05	1.82	1.28	1.01	0.97	0.56
E5-09	Motor Induction Voltage Constant 1 (Ke)	mVs/rad	248.1	253.6	250.0	280.9	264.2	280.4	311.9	268.0
E5-24	Motor Induction Voltage Constant 2 (Ke)	mV/(r/min)	0.0	0.0	0.0	0.0	0.0	0.0	0.0	0.0
E1-04	Maximum Output Frequency	Hz	87.5	87.5	87.5	87.5	87.5	87.5	87.5	87.5
E1-05	Maximum Voltage	V	190.0	190.0	190.0	190.0	190.0	190.0	190.0	190.0
E1-06	Base Frequency	Hz	87.5	87.5	87.5	87.5	87.5	87.5	87.5	87.5
E1-09	Minimum Output Frequency	Hz	4.4	4.4	4.4	4.4	4.4	4.4	4.4	4.4
L3-24	Motor Acceleration Time for Inertia Calculations	s	0.102	0.101	0.098	0.130	0.127	0.193	0.191	0.187
n8-49	d-Axis Current for High Efficiency Control (OLV/PM)	%	-16.5	-11.3	-12.8	-16.8	-15.6	-10.7	-9.6	-13.3

## B.7 Parameters that Change with the Motor Code Selection

**Table B.11 400 V, 1750 r/min Type YASKAWA SSR1 Series IPM Motor**

No.	Name	Unit	Default Settings									
E5-01	Motor Code Selection	–	1232	1233	1235	1236	1238	123A	123B	123D	123E	123F
	Voltage Class	V	400	400	400	400	400	400	400	400	400	400
	Rated Power	kW	0.4	0.75	1.5	2.2	3.7	5.5	7.5	11	15	18
	Rated Speed	r/min	1750	1750	1750	1750	1750	1750	1750	1750	1750	1750
E5-02	Motor Rated Power	kW	0.4	0.75	1.5	2.2	3.7	5.5	7.5	11.0	15	18.50
E5-03	Motor Rated Current	A	0.89	1.56	2.81	4.27	7.08	10.31	13.65	20.7	27.5	33.4
E5-04	Number of Motor Poles	–	6	6	6	6	6	6	6	6	6	6
E5-05	Motor Stator Resistance (r1)	Ω	25.370	9.136	6.010	3.297	1.798	0.982	0.786	0.349	0.272	0.207
E5-06	Motor d-Axis Inductance (Ld)	mH	169.00	92.08	67.71	34.40	32.93	22.7	16.49	13.17	10.30	8.72
E5-07	Motor q-Axis Inductance (Lq)	mH	197.50	119.56	81.71	54.00	37.70	26.80	23.46	15.60	12.77	11.22
E5-09	Motor Induction Voltage Constant 1 (Ke)	mVs/rad	392.6	440.6	478.3	466.3	478.8	478.1	520.0	481.5	498.8	509.5
E5-24	Motor Induction Voltage Constant 2 (Ke)	mV/(r/min)	0.0	0.0	0.0	0.0	0.0	0.0	0.0	0.0	0.0	0.0
E1-04	Maximum Output Frequency	Hz	87.5	87.5	87.5	87.5	87.5	87.5	87.5	87.5	87.5	87.5
E1-05	Maximum Voltage	V	380.0	380.0	380.0	380.0	380.0	380.0	380.0	380.0	380.0	380.0
E1-06	Base Frequency	Hz	87.5	87.5	87.5	87.5	87.5	87.5	87.5	87.5	87.5	87.5
E1-09	Minimum Output Frequency	Hz	4.4	4.4	4.4	4.4	4.4	4.4	4.4	4.4	4.4	4.4
L3-24	Motor Acceleration Time for Inertia Calculations	s	0.092	0.076	0.052	0.066	0.075	0.083	0.077	0.084	0.102	0.101
n8-49	d-Axis Current for High Efficiency Control (OLV/PM)	%	-8.6	-11.5	-10.3	-19.8	-8.5	-11.0	-18.6	-12.5	-15.5	-17.9

No.	Name	Unit	Default Settings									
E5-01	Motor Code Selection	–	1240	1242	1243	1244	1245	1246	1247	1248	1249	124A
	Voltage Class	V	400	400	400	400	400	400	400	400	400	400
	Rated Power	kW	22	30	37	45	55	75	90	110	132	160
	Rated Speed	r/min	1750	1750	1750	1750	1750	1750	1750	1750	1750	1750
E5-02	Motor Rated Power	kW	22.00	30.00	37.00	45.00	55.00	75.00	90.00	110.00	132	160
E5-03	Motor Rated Current	A	39.8	52.0	65.8	77.5	92.7	126.6	160.4	183.3	222.9	267.7
E5-04	Number of Motor Poles	–	6	6	6	6	6	6	6	6	6	6
E5-05	Motor Stator Resistance (r1)	Ω	0.148	0.235	0.079	0.054	0.049	0.029	0.019	0.017	0.012	0.008
E5-06	Motor d-Axis Inductance (Ld)	mH	6.81	5.4	4.08	3.36	3.16	2.12	1.54	1.44	1.21	0.97
E5-07	Motor q-Axis Inductance (Lq)	mH	8.47	7.26	5.12	3.94	3.88	2.61	2.06	2.21	1.46	1.28
E5-09	Motor Induction Voltage Constant 1 (Ke)	mVs/rad	503.9	561.7	528.5	558.1	623.8	594.5	524.1	583.7	563.6	601.2
E5-24	Motor Induction Voltage Constant 2 (Ke)	mV/(r/min)	0.0	0.0	0.0	0.0	0.0	0.0	0.0	0.0	0	0
E1-04	Maximum Output Frequency	Hz	87.5	87.5	87.5	87.5	87.5	87.5	87.5	87.5	87.5	87.5
E1-05	Maximum Voltage	V	380.0	380.0	380.0	380.0	380.0	380.0	380.0	380.0	380	380
E1-06	Base Frequency	Hz	87.5	87.5	87.5	87.5	87.5	87.5	87.5	87.5	87.5	87.5
E1-09	Minimum Output Frequency	Hz	4.4	4.4	4.4	4.4	4.4	4.4	4.4	4.4	4.4	4.4
L3-24	Motor Acceleration Time for Inertia Calculations	s	0.098	0.130	0.127	0.193	0.191	0.187	0.208	0.254	0.243	0.338
n8-49	d-Axis Current for High Efficiency Control (OLV/PM)	%	-15.1	-16.8	-14.1	-8.8	-9.6	-10.3	-17.0	-21.7	-10.9	-13.2

Table B.12 200 V, 1450 r/min Type YASKAWA SSR1 Series IPM Motor

No.	Name	Unit	Default Settings							
E5-01	Motor Code Selection	–	1302	1303	1305	1306	1308	130A	130B	130D
	Voltage Class	V	200	200	200	200	200	200	200	200
	Rated Power	kW	0.4	0.75	1.5	2.2	3.7	5.5	7.5	11
	Rated Speed	r/min	1450	1450	1450	1450	1450	1450	1450	1450
E5-02	Motor Rated Power	kW	0.4	0.75	1.5	2.2	3.7	5.5	7.5	11.0
E5-03	Motor Rated Current	A	1.88	3.13	5.63	8.33	14.17	20.63	27.71	39.6
E5-04	Number of Motor Poles	–	6	6	6	6	6	6	6	6
E5-05	Motor Stator Resistance (r1)	Ω	3.190	1.940	1.206	0.665	0.341	0.252	0.184	0.099
E5-06	Motor d-Axis Inductance (Ld)	mH	32.15	26.12	14.72	12.27	8.27	6.49	6.91	4.07
E5-07	Motor q-Axis Inductance (Lq)	mH	41.74	34.30	20.15	14.77	9.81	7.74	7.66	4.65
E5-09	Motor Induction Voltage Constant 1 (Ke)	mVs/rad	264.3	269.6	284.3	287.1	284.5	298.0	335.0	303.9
E5-24	Motor Induction Voltage Constant 2 (Ke)	mV/(r/min)	0.0	0.0	0.0	0.0	0.0	0.0	0.0	0.0
E1-04	Maximum Output Frequency	Hz	72.5	72.5	72.5	72.5	72.5	72.5	72.5	72.5
E1-05	Maximum Voltage	V	190.0	190.0	190.0	190.0	190.0	190.0	190.0	190.0
E1-06	Base Frequency	Hz	72.5	72.5	72.5	72.5	72.5	72.5	72.5	72.5
E1-09	Minimum Output Frequency	Hz	3.6	3.6	3.6	3.6	3.6	3.6	3.6	3.6
L3-24	Motor Acceleration Time for Inertia Calculations	s	0.098	0.071	0.066	0.087	0.085	0.072	0.084	0.096
n8-49	d-Axis Current for High Efficiency Control (OLV/PM)	%	-6.6	-10.9	-13.5	-9.0	-9.5	-10.1	-6.0	-9.3

No.	Name	Unit	Default Settings							
E5-01	Motor Code Selection	–	130E	130F	1310	1312	1313	1314	1315	
	Voltage Class	V	200	200	200	200	200	200	200	
	Rated Power	kW	15	18	22	30	37	45	55	
	Rated Speed	r/min	1450	1450	1450	1450	1450	1450	1450	
E5-02	Motor Rated Power	kW	15.00	18.50	22.00	30.00	37.00	45.00	55.00	
E5-03	Motor Rated Current	A	55.5	65.6	75.1	105.2	126.0	153.1	186.5	
E5-04	Number of Motor Poles	–	6	6	6	6	6	6	6	
E5-05	Motor Stator Resistance (r1)	Ω	0.075	0.057	0.041	0.034	0.023	0.015	0.012	
E5-06	Motor d-Axis Inductance (Ld)	mH	3.29	2.53	1.98	1.75	1.48	1.04	0.87	
E5-07	Motor q-Axis Inductance (Lq)	mH	3.84	3.01	2.60	2.17	1.70	1.31	1.10	
E5-09	Motor Induction Voltage Constant 1 (Ke)	mVs/rad	311.2	300.9	327.7	354.2	369.6	351.6	374.7	
E5-24	Motor Induction Voltage Constant 2 (Ke)	mV/(r/min)	0.0	0.0	0.0	0.0	0.0	0.0	0.0	
E1-04	Maximum Output Frequency	Hz	72.5	72.5	72.5	72.5	72.5	72.5	72.5	
E1-05	Maximum Voltage	V	190.0	190.0	190.0	190.0	190.0	190.0	190.0	
E1-06	Base Frequency	Hz	72.5	72.5	72.5	72.5	72.5	72.5	72.5	
E1-09	Minimum Output Frequency	Hz	3.6	3.6	3.6	3.6	3.6	3.6	3.6	
L3-24	Motor Acceleration Time for Inertia Calculations	s	0.085	0.080	0.122	0.108	0.161	0.160	0.175	
n8-49	d-Axis Current for High Efficiency Control (OLV/PM)	%	-10.7	-13.2	-15.7	-11.5	-7.0	-11.8	-10.2	

## B.7 Parameters that Change with the Motor Code Selection

**Table B.13 400 V, 1450 r/min Type YASKAWA SSR1 Series IPM Motor**

No.	Name	Unit	Default Settings									
E5-01	Motor Code Selection	–	1332	1333	1335	1336	1338	133A	133B	133D	133E	133F
	Voltage Class	V	400	400	400	400	400	400	400	400	400	400
	Rated Power	kW	0.4	0.75	1.5	2.2	3.7	5.5	7.5	11	15	18
	Rated Speed	r/min	1450	1450	1450	1450	1450	1450	1450	1450	1450	1450
E5-02	Motor Rated Power	kW	0.4	0.75	1.5	2.2	3.7	5.5	7.5	11.0	15	18.50
E5-03	Motor Rated Current	A	0.94	1.56	2.81	4.27	6.98	10.21	13.85	19.5	27.4	32.9
E5-04	Number of Motor Poles	–	6	6	6	6	6	6	6	6	6	6
E5-05	Motor Stator Resistance (r1)	Ω	12.760	7.421	4.825	2.656	1.353	0.999	0.713	0.393	0.295	0.223
E5-06	Motor d-Axis Inductance (Ld)	mH	128.60	85.11	58.87	46.42	31.73	26.20	27.06	15.51	12.65	9.87
E5-07	Motor q-Axis Inductance (Lq)	mH	166.96	113.19	80.59	60.32	40.45	30.94	33.45	19.63	15.87	12.40
E5-09	Motor Induction Voltage Constant 1 (Ke)	mVs/rad	528.6	544.2	568.5	572.8	562.9	587.6	670.1	612.7	624.6	610.4
E5-24	Motor Induction Voltage Constant 2 (Ke)	mV/(r/min)	0.0	0.0	0.0	0.0	0.0	0.0	0.0	0.0	0.0	0.0
E1-04	Maximum Output Frequency	Hz	72.5	72.5	72.5	72.5	72.5	72.5	72.5	72.5	72.5	72.5
E1-05	Maximum Voltage	V	380.0	380.0	380.0	380.0	380.0	380.0	380.0	380.0	380.0	380.0
E1-06	Base Frequency	Hz	72.5	72.5	72.5	72.5	72.5	72.5	72.5	72.5	72.5	72.5
E1-09	Minimum Output Frequency	Hz	3.6	3.6	3.6	3.6	3.6	3.6	3.6	3.6	3.6	3.6
L3-24	Motor Acceleration Time for Inertia Calculations	s	0.098	0.071	0.066	0.087	0.085	0.072	0.084	0.096	0.085	0.080
n8-49	d-Axis Current for High Efficiency Control (OLV/PM)	%	-6.6	-9.2	-13.5	-12.1	-13.7	-10.1	-12.2	-15.5	-15.1	-16.0

No.	Name	Unit	Default Settings									
E5-01	Motor Code Selection	–	1340	1342	1343	1344	1345	1346	1347	1348	1349	
	Voltage Class	V	400	400	400	400	400	400	400	400	400	
	Rated Power	kW	22	30	37	45	55	75	90	110	132	
	Rated Speed	r/min	1450	1450	1450	1450	1450	1450	1450	1450	1450	
E5-02	Motor Rated Power	kW	22.00	30.00	37.00	45.00	55.00	75.00	90.00	110.00	132.00	
E5-03	Motor Rated Current	A	37.6	52.5	63.2	76.4	96.1	124.0	153.1	186.5	226.0	
E5-04	Number of Motor Poles	–	6	6	6	6	6	6	6	6	6	
E5-05	Motor Stator Resistance (r1)	Ω	0.164	0.137	0.093	0.059	0.048	0.028	0.024	0.015	0.011	
E5-06	Motor d-Axis Inductance (Ld)	mH	7.90	7.01	5.93	4.17	3.11	2.32	2.20	1.45	1.23	
E5-07	Motor q-Axis Inductance (Lq)	mH	10.38	8.68	6.79	5.22	4.55	2.97	3.23	1.88	1.67	
E5-09	Motor Induction Voltage Constant 1 (Ke)	mVs/rad	655.4	708.4	739.2	703.0	747.1	639.3	708.0	640.7	677.0	
E5-24	Motor Induction Voltage Constant 2 (Ke)	mV/(r/min)	0.0	0.0	0.0	0.0	0.0	0.0	0.0	0.0	0.0	
E1-04	Maximum Output Frequency	Hz	72.5	72.5	72.5	72.5	72.5	72.5	72.5	72.5	72.5	
E1-05	Maximum Voltage	V	380.0	380.0	380.0	380.0	380.0	380.0	380.0	380.0	380.0	
E1-06	Base Frequency	Hz	72.5	72.5	72.5	72.5	72.5	72.5	72.5	72.5	72.5	
E1-09	Minimum Output Frequency	Hz	3.6	3.6	3.6	3.6	3.6	3.6	3.6	3.6	3.6	
L3-24	Motor Acceleration Time for Inertia Calculations	s	0.122	0.108	0.161	0.160	0.175	0.171	0.213	0.201	0.281	
n8-49	d-Axis Current for High Efficiency Control (OLV/PM)	%	-15.7	-11.5	-6.8	-11.5	-14.8	-15.8	-19.6	-14.9	-15.1	



Table B.14 200 V, 1150 r/min Type YASKAWA SSR1 Series IPM Motor

No.	Name	Unit	Default Settings						
			1402	1403	1405	1406	1408	140A	140B
E5-01	Motor Code Selection	–	1402	1403	1405	1406	1408	140A	140B
	Voltage Class	V	200	200	200	200	200	200	200
	Rated Power	kW	0.4	0.75	1.5	2.2	3.7	5.5	7.5
	Rated Speed	r/min	1150	1150	1150	1150	1150	1150	1150
E5-02	Motor Rated Power	kW	0.4	0.75	1.5	2.2	3.7	5.5	7.5
E5-03	Motor Rated Current	A	1.88	3.02	6.00	8.85	14.27	20.21	26.67
E5-04	Number of Motor Poles	–	6	6	6	6	6	6	6
E5-05	Motor Stator Resistance (r1)	Ω	4.832	2.704	1.114	0.511	0.412	0.303	0.165
E5-06	Motor d-Axis Inductance (Ld)	mH	48.68	32.31	19.22	12.15	7.94	11.13	6.59
E5-07	Motor q-Axis Inductance (Lq)	mH	63.21	40.24	24.38	15.35	11.86	14.06	8.55
E5-09	Motor Induction Voltage Constant 1 (Ke)	mVs/rad	320.4	327.1	364.4	344.4	357.5	430.8	391.5
E5-24	Motor Induction Voltage Constant 2 (Ke)	mV/(r/min)	0.0	0.0	0.0	0.0	0.0	0.0	0.0
E1-04	Maximum Output Frequency	Hz	57.5	57.5	57.5	57.5	57.5	57.5	57.5
E1-05	Maximum Voltage	V	190.0	190.0	190.0	190.0	190.0	190.0	190.0
E1-06	Base Frequency	Hz	57.5	57.5	57.5	57.5	57.5	57.5	57.5
E1-09	Minimum Output Frequency	Hz	2.9	2.9	2.9	2.9	2.9	2.9	2.9
L3-24	Motor Acceleration Time for Inertia Calculations	s	0.062	0.044	0.080	0.090	0.067	0.072	0.088
n8-49	d-Axis Current for High Efficiency Control (OLV/PM)	%	-8.8	-9.9	-9.3	-10.0	-17.7	-12.3	-15.3

No.	Name	Unit	Default Settings						
			140D	140E	140F	1410	1412	1413	1414
E5-01	Motor Code Selection	–	140D	140E	140F	1410	1412	1413	1414
	Voltage Class	V	200	200	200	200	200	200	200
	Rated Power	kW	11	15	18	22	30	37	45
	Rated Speed	r/min	1150	1150	1150	1150	1150	1150	1150
E5-02	Motor Rated Power	kW	11.0	15	18.50	22.00	30.00	37.00	45.00
E5-03	Motor Rated Current	A	39.9	55.6	63.5	74.4	104.2	129.6	154.2
E5-04	Number of Motor Poles	–	6	6	6	6	6	6	6
E5-05	Motor Stator Resistance (r1)	Ω	0.113	0.084	0.066	0.048	0.035	0.023	0.016
E5-06	Motor d-Axis Inductance (Ld)	mH	4.96	3.83	3.33	2.38	2.04	1.53	1.16
E5-07	Motor q-Axis Inductance (Lq)	mH	6.12	4.65	4.50	3.15	2.86	2.27	1.54
E5-09	Motor Induction Voltage Constant 1 (Ke)	mVs/rad	384.4	372.1	421.3	410.9	436.1	428.8	433.3
E5-24	Motor Induction Voltage Constant 2 (Ke)	mV/(r/min)	0.0	0.0	0.0	0.0	0.0	0.0	0.0
E1-04	Maximum Output Frequency	Hz	57.5	57.5	57.5	57.5	57.5	57.5	57.5
E1-05	Maximum Voltage	V	190.0	190.0	190.0	190.0	190.0	190.0	190.0
E1-06	Base Frequency	Hz	57.5	57.5	57.5	57.5	57.5	57.5	57.5
E1-09	Minimum Output Frequency	Hz	2.9	2.9	2.9	2.9	2.9	2.9	2.9
L3-24	Motor Acceleration Time for Inertia Calculations	s	0.073	0.062	0.091	0.092	0.125	0.122	0.135
n8-49	d-Axis Current for High Efficiency Control (OLV/PM)	%	-13.9	-14.4	-17.9	-15.9	-17.9	-20.1	-13.7

## B.7 Parameters that Change with the Motor Code Selection

**Table B.15 400 V, 1150 r/min Type YASKAWA SSR1 Series IPM Motor**

No.	Name	Unit	Default Settings								
E5-01	Motor Code Selection	–	1432	1433	1435	1436	1438	143A	143B	143D	143E
	Voltage Class	V	400	400	400	400	400	400	400	400	400
	Rated Power	kW	0.4	0.75	1.5	2.2	3.7	5.5	7.5	11	15
	Rated Speed	r/min	1150	1150	1150	1150	1150	1150	1150	1150	1150
E5-02	Motor Rated Power	kW	0.4	0.75	1.5	2.2	3.7	5.5	7.5	11.0	15
E5-03	Motor Rated Current	A	0.94	1.51	3.00	4.43	7.08	10.10	13.33	19.9	27.8
E5-04	Number of Motor Poles	–	6	6	6	6	6	6	6	6	6
E5-05	Motor Stator Resistance (r1)	Ω	19.320	10.800	4.456	2.044	1.483	1.215	0.660	0.443	0.331
E5-06	Motor d-Axis Inductance (Ld)	mH	194.70	129.20	76.88	48.60	37.58	44.54	26.36	19.10	15.09
E5-07	Motor q-Axis Inductance (Lq)	mH	252.84	160.90	97.52	61.40	47.65	56.26	34.20	24.67	18.56
E5-09	Motor Induction Voltage Constant 1 (Ke)	mVs/rad	640.9	654.1	728.8	688.9	702.0	861.5	783.0	762.2	749.6
E5-24	Motor Induction Voltage Constant 2 (Ke)	mV/(r/min)	0.0	0.0	0.0	0.0	0.0	0.0	0.0	0.0	0.0
E1-04	Maximum Output Frequency	Hz	57.5	57.5	57.5	57.5	57.5	57.5	57.5	57.5	57.5
E1-05	Maximum Voltage	V	380.0	380.0	380.0	380.0	380.0	380.0	380.0	380.0	380.0
E1-06	Base Frequency	Hz	57.5	57.5	57.5	57.5	57.5	57.5	57.5	57.5	57.5
E1-09	Minimum Output Frequency	Hz	2.9	2.9	2.9	2.9	2.9	2.9	2.9	2.9	2.9
L3-24	Motor Acceleration Time for Inertia Calculations	s	0.062	0.044	0.080	0.090	0.067	0.072	0.088	0.073	0.062
n8-49	d-Axis Current for High Efficiency Control (OLV/PM)	%	-8.8	-9.9	-9.3	-10.0	-12.8	-12.3	-15.3	-16.7	-14.9

No.	Name	Unit	Default Settings								
E5-01	Motor Code Selection	–	143F	1440	1442	1443	1444	1445	1446	1447	1448
	Voltage Class	V	400	400	400	400	400	400	400	400	400
	Rated Power	kW	18	22	30	37	45	55	75	90	110
	Rated Speed	r/min	1150	1150	1150	1150	1150	1150	1150	1150	1150
E5-02	Motor Rated Power	kW	18.50	22.00	30.00	37.00	45.00	55.00	75.00	90.00	110.00
E5-03	Motor Rated Current	A	31.8	37.2	52.1	64.8	76.6	92.0	127.1	150.5	185.4
E5-04	Number of Motor Poles	–	6	6	6	6	6	6	6	6	6
E5-05	Motor Stator Resistance (r1)	Ω	0.264	0.192	0.140	0.093	0.063	0.051	0.033	0.027	0.015
E5-06	Motor d-Axis Inductance (Ld)	mH	13.32	9.52	8.16	6.13	4.63	3.96	3.03	2.60	1.89
E5-07	Motor q-Axis Inductance (Lq)	mH	18.00	12.60	11.40	9.10	6.15	5.00	5.14	3.28	2.33
E5-09	Motor Induction Voltage Constant 1 (Ke)	mVs/rad	842.7	821.8	872.3	857.7	866.6	854.0	823.1	853.4	829.2
E5-24	Motor Induction Voltage Constant 2 (Ke)	mV/(r/min)	0.0	0.0	0.0	0.0	0.0	0.0	0.0	0.0	0.0
E1-04	Maximum Output Frequency	Hz	57.5	57.5	57.5	57.5	57.5	57.5	57.5	57.5	57.5
E1-05	Maximum Voltage	V	380.0	380.0	380.0	380.0	380.0	380.0	380.0	380.0	380.0
E1-06	Base Frequency	Hz	57.5	57.5	57.5	57.5	57.5	57.5	57.5	57.5	57.5
E1-09	Minimum Output Frequency	Hz	2.9	2.9	2.9	2.9	2.9	2.9	2.9	2.9	2.9
L3-24	Motor Acceleration Time for Inertia Calculations	s	0.091	0.092	0.125	0.122	0.135	0.147	0.161	0.154	0.212
n8-49	d-Axis Current for High Efficiency Control (OLV/PM)	%	-17.9	-15.9	-17.7	-20.1	-13.8	-12.5	-28.8	-13.3	-11.6

# Appendix: C

## MEMOBUS/Modbus Communications

C.1 MEMOBUS/MODBUS CONFIGURATION .....	412
C.2 COMMUNICATION SPECIFICATIONS.....	413
C.3 CONNECTING TO A NETWORK .....	414
C.4 MEMOBUS/MODBUS SETUP PARAMETERS .....	416
C.5 DRIVE OPERATIONS BY MEMOBUS/MODBUS.....	419
C.6 COMMUNICATIONS TIMING .....	420
C.7 MESSAGE FORMAT.....	421
C.8 MESSAGE EXAMPLES .....	423
C.9 MEMOBUS/MODBUS DATA TABLE .....	425
C.10 ENTER COMMAND.....	434
C.11 COMMUNICATION ERRORS .....	435
C.12 SELF-DIAGNOSTICS .....	436

### C.1 MEMOBUS/Modbus Configuration

Drives can be controlled from a PLC or other master device via serial communications using the MEMOBUS/Modbus protocol.

MEMOBUS/Modbus communication can be configured using one master (PLC) and a maximum of 255 slaves. The drive has slave functionality only, meaning that serial communication is normally initiated from the master and responded to by the slaves.

The master performs serial communications with only one slave at a time. The address or node for each slave must be set beforehand so that the master can communicate with the slave at that address. A slave that receives a command from the master will perform the specified function and then send a response back to the master.

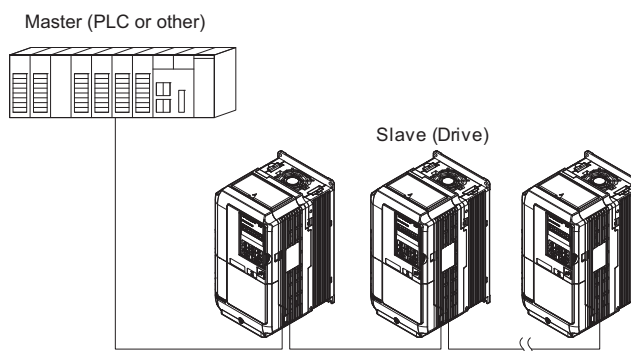


Figure C.1 Connecting Multiple Drives to a PLC

## C.2 Communication Specifications

MEMOBUS/Modbus specifications appear in the following table:

Item	Specifications	
Interface	RS-422, RS-485	
Communications Cycle	Asynchronous (Start-stop synchronization)	
Communication Parameters	Communication Speeds Available	1.2; 2.4; 4.8; 9.6; 19.2; 38.4; 57.6; 76.8; 115.2 kbps
	Data length	8 bit (fixed)
	Parity	Select even, odd, or none
	Stop bit	1 bit (fixed)
Protocol	MEMOBUS/Modbus (using RTU mode only)	
Max Number of Slaves	255 drives	

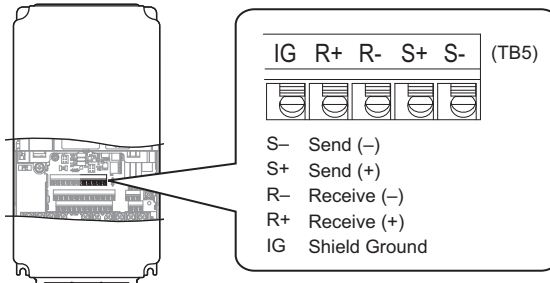
## C.3 Connecting to a Network

This section explains how to connect the drive to a MEMOBUS/Modbus network and the network termination required.

### ◆ Network Cable Connection

Follow the instructions below to connect the drive to a MEMOBUS/Modbus network.

1. With the power shut off, connect the communications cable to the drive and the master. Use terminals TB5 for MEMOBUS/Modbus.



**Figure C.2 Serial Communications Cable Connection Terminals (TB5)**

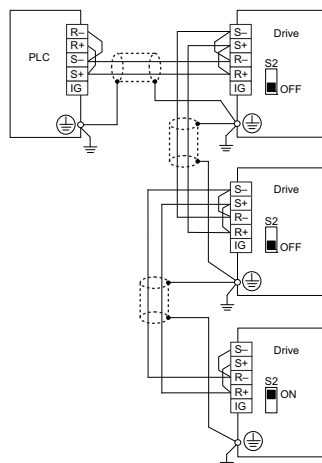
**Note:** Separate the communications cables from the main circuit cables and other wiring and power cables. Use shielded cables for the communications cables, and properly shielded clamps to prevent problems with noise. When using RS-485 communications, connect S+ to R+, and S- to R- as shown in the diagram below.

2. Check or set the termination resistor selection at all slaves. Use the description in [Network Termination on page 415](#) for slaves that are E1000 drives.
3. Switch the power on.
4. Set the parameters needed for serial communications (H5-01 through H5-12) using the digital operator.
5. Shut the power off and wait until the display on the digital operator goes out completely.
6. Turn the power back on.
7. The drive is now ready to begin communicating with the master.

### ◆ Wiring Diagram for Multiple Connection

*Figure C.3* and *Figure C.4* explain the wiring diagrams for multiple connections using MEMOBUS/Modbus communication.

#### ■ RS-485 Interface



**Figure C.3 RS-485 Interface**

- Note:**
1. Turn on the DIP switch on the drive that is located at the end of the network. All other slave devices must have this DIP switch set to the OFF position.
  2. Set H5-07 to "1" when using the RS-485 interface.

■ RS-422 Interface

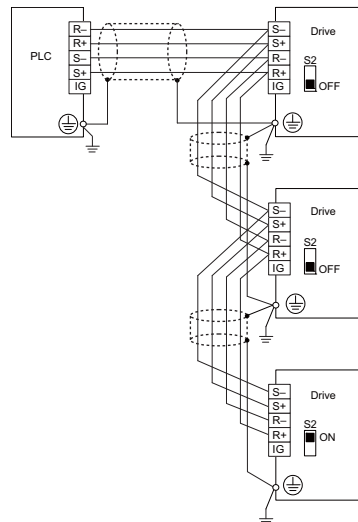


Figure C.4 RS-422 Interface

- Note:**
1. Turn on the DIP switch on the drive that is located at the end of the network. All other slave devices must have this DIP switch set to the OFF position.
  2. Set H5-07 to “0” when using the RS-485 interface.  
Set H5-07 to 1 when using the RS-422 interface in multi-drop circuit. Set H5-07 to 0 when using the RS-422 interface in point-to-point circuit.

◆ Network Termination

The two ends of the MEMOBUS/Modbus network line have to be terminated. The drive has a built in termination resistor that can be enabled or disabled using DIP switch S2. If a drive is located at the end of a network line, enable the termination resistor by setting DIP switch S2 to the ON position. Disable the termination resistor on all slaves that are not located at the network line end.

Figure C.5 illustrates the setting of DIP switch S2.

To set the DIP switch on the terminal board, use an appropriate sized tool with a tip of approximately 8 mm in width.

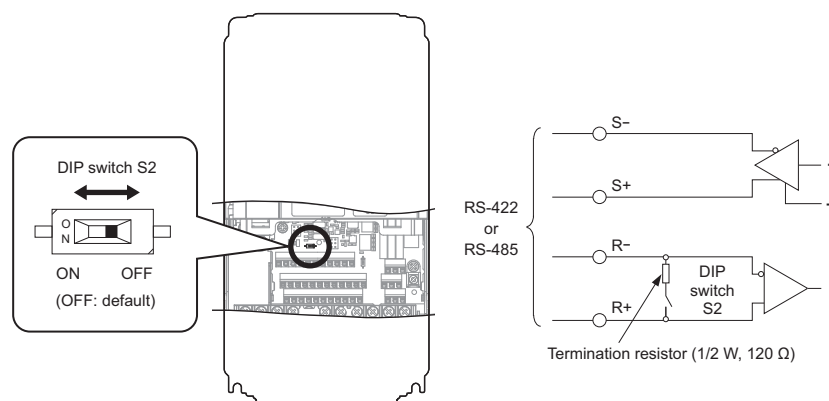


Figure C.5 Serial Communications Terminal and DIP Switch S2

## C.4 MEMOBUS/Modbus Setup Parameters

### ◆ MEMOBUS/Modbus Serial Communication

This section describes parameters necessary to set up MEMOBUS/Modbus communications.

#### ■ H5-01: Drive Slave Address

Sets the drive slave address used for MEMOBUS/Modbus communications.

**Note:** After changing this parameter, the power must be cycled to enable the new setting.

No.	Name	Setting Range	Default
H5-01	Drive Slave Address	0 to FFH < >	1FH

<|> If the address is set to 0, no response will be provided during communications.

For serial communications to work, each individual slave drive must be assigned a unique slave address. Setting H5-01 to any value besides 0 assigns the drive its address in the network. Slave address don't need to be assigned in sequential order, but each address needs to be unique so that no two drives have the same address.

#### ■ H5-02: Communication Speed Selection

Sets the MEMOBUS/Modbus communications speed.

**Note:** After changing this parameter, the power must be cycled to enable the new setting.

No.	Name	Setting Range	Default
H5-02	Communication Speed Selection	0 to 8	3

H5-02	Communication Speed	H5-02	Communication Speed
0	1200 bps	5	38400 bps
1	2400 bps	6	57600 bps
2	4800 bps	7	76800 bps
3	9600 bps	8	115200 bps
4	19200 bps		

#### ■ H5-03: Communication Parity Selection

Sets the parity used for MEMOBUS/Modbus communications.

**Note:** After changing this parameter, the power must be cycled to enable the new setting.

No.	Name	Setting Range	Default
H5-03	Communication Parity Selection	0 to 2	0

**Setting 0: No parity**

**Setting 1: Even parity**

**Setting 2: Odd parity**

#### ■ H5-04: Stopping Method after Communication Error

Selects the stopping method after a communications error (CE) has occurred.

No.	Name	Setting Range	Default
H5-04	Stopping Method after Communication Error	0 to 3	3

**Setting 0: Ramp to stop (uses the deceleration time currently enabled)**

**Setting 1: Fast Stop (uses the deceleration time in C1-09)**

**Setting 2: Coast to stop**

**Setting 3: Alarm only (continue operation)**



### ■ H5-05: Communication Fault Detection Selection

Enables or disabled the communication error (CE) detection for MEMOBUS/Modbus communications.

No.	Name	Setting Range	Default
H5-05	Communication Fault Detection Selection	0 or 1	1

#### Setting 0: Disabled

No communication error detection. The drive continues operation.

#### Setting 1: Enabled

If the drive does not receive data from the master for longer than the time set to H5-09, then a CE fault will be triggered and the drive will operate as determined by parameter H5-04.

### ■ H5-06: Drive Transmit Wait Time

Sets the time the drive waits after receiving data from a master until responding data.

No.	Name	Setting Range	Default
H5-06	Drive Transmit Wait Time	5 to 65 ms	5 ms

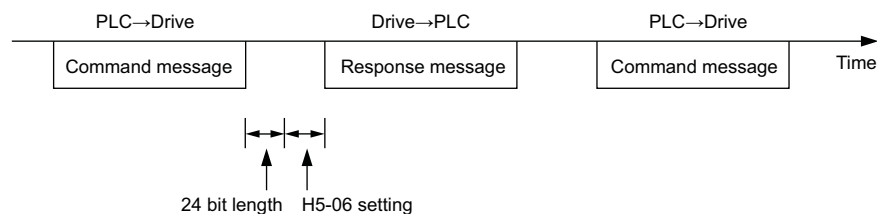


Figure C.6 Drive Transmit Wait Time Setting

### ■ H5-07: RTS Control Selection

Enables or disables RTS control.

No.	Name	Setting Range	Default
H5-07	RTS Control Selection	0 or 1	1

#### Setting 0: Disabled. RTS is always on.

Use this setting when using RS-485 signals for communications or when using the RS-422 signals for point-to-point communications.

#### Setting 1: Enabled. RTS switches while sending.

Use this setting with point-to-point or multi-drop RS-422 communications.

### ■ H5-09: CE Detection Time

Sets the time the communications must be lost before the drive triggers a CE fault.

No.	Name	Setting Range	Default
H5-09	CE Detection Time	0.0 to 10.0 s	2.0 s

### ■ H5-10: Unit Selection for MEMOBUS/Modbus Register 0025H

Sets the unit for the output voltage monitor value in MEMOBUS/Modbus register 0025H.

No.	Name	Setting Range	Default
H5-10	Unit Selection for MEMOBUS/Modbus Register 0025H	0 or 1	0

#### Setting 0: 0.1 V units

#### Setting 1: 1 V units

## C.4 MEMOBUS/Modbus Setup Parameters

---

### ■ H5-11: Communications Enter Function Selection

Selects if an Enter command is needed to change parameter values via MEMOBUS/Modbus communications. *Refer to Enter Command on page 434.*

No.	Name	Setting Range	Default
H5-11	Communications Enter Function Selection	0 or 1	0

#### Setting 0: Enter command necessary

Parameter changes become effective after an Enter command. An Enter command must only be sent after the last parameter change, not for each single parameter.

#### Setting 1: Enter command not necessary

Parameter value changes become effective immediately without the need to send an Enter command.

### ■ H5-12: Run Command Method Selection

Selects the type of sequence used when the Run command source is set to MEMOBUS/Modbus communications (b1-02, b1-16 = 2).

No.	Name	Setting Range	Default
H5-12	Run Command Method Selection	0 or 1	0

#### Setting 0: FWD/Stop, REV/Stop

Setting bit 0 of MEMOBUS/Modbus register will start and stop the drive in the forward direction. Setting bit 1 will start and stop the drive in reverse.

#### Setting 1: Run/Stop, FWD/REV

Setting bit 0 of MEMOBUS/Modbus register will start and stop the drive. Setting bit 1 changes the direction.

## C.5 Drive Operations by MEMOBUS/Modbus

The drive operations that can be performed by MEMOBUS/Modbus communication depend on drive parameter settings. This section explains the functions that can be used and related parameter settings.

### ◆ Observing the Drive Operation

A PLC can perform the following actions with MEMOBUS/Modbus communications at any time regardless of parameter settings (except H5-□□).

- Observe drive status and drive control terminal status from a PLC.
- Read and write parameters.
- Set and reset faults.
- Set multi-function inputs. Inputs settings from the input terminals S□ and from MEMOBUS/Modbus communications are both linked by an OR operation.

### ◆ Controlling the Drive

To start and stop the drive or set the frequency reference using MEMOBUS/Modbus communications, an external reference must be selected and the parameters listed in [Table C.1](#) must be adjusted accordingly.

**Table C.1 Setting Parameters for Drive Control from MEMOBUS/Modbus**

Reference Source	Parameter	Name	Required Setting
External Reference 1	b1-01	Frequency Reference Selection 1	2
	b1-02	Run Command Selection 1	2
External Reference 2	b1-15	Frequency Reference Selection 2	2
	b1-16	Run Command Selection 2	2

*Refer to b1-01: Frequency Reference Selection 1 on page 131 and Refer to b1-02: Run Command Selection 1 on page 132 for details on external reference parameter selections. Refer to Setting 2: External Reference 1/2 Selection on page 183 for instructions on how to select external reference 1 and 2.*

## C.6 Communications Timing

To prevent overrun in the slave drive, the master should wait a certain time between sending messages to the same drive. In the same way, the slave drive must wait before sending response messages to prevent an overrun in the master. This section explains the message timing.

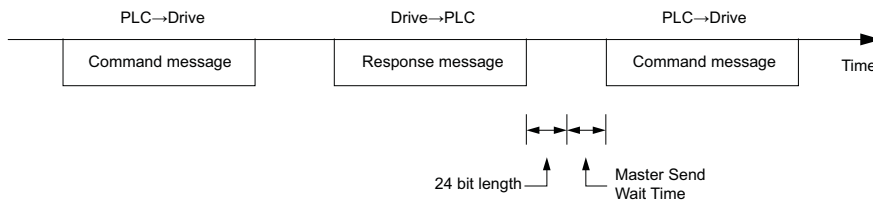
### ◆ Command Messages from Master to Drive

In order to prevent overrun and data loss, the master must wait between receiving a response and sending the same type of command as before to the same slave drive. The minimum wait time depends on the command as shown in the table below.

**Table C.2 Minimum Wait Time for Sending Messages**

Command Type	Example	Minimum Wait Time
1	<ul style="list-style-type: none"> <li>Control command (Run, Stop)</li> <li>Set inputs/outputs</li> <li>Read monitors and parameter values</li> </ul>	5 ms
2	Write parameters	H5-11 = 0: 50 ms H5-11 = 1: 200ms </>
3	Save changes using an Enter command	200 ms to 2 s, depending on the number of parameters that were changed </>
4	Enter with storage to drive EEPROM after initialization	5 s

<1> If the drive receives command type 1 data during the minimum wait time, it will perform the command and then respond. However, if it receives a command type 2 or 3 during that time, either a communication error will result or the command will be ignored.

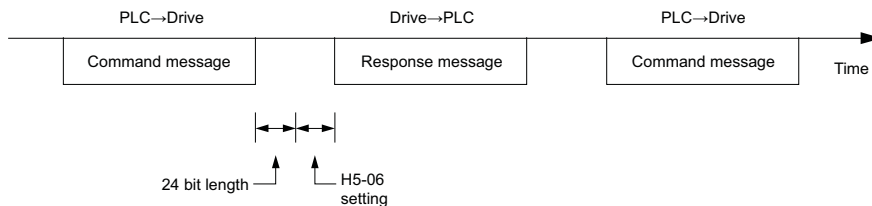


**Figure C.7 Minimum Wait Time for Sending Messages**

A timer should be set in the master to check how long it takes for the slave drive(s) to respond to the master. If no response is received within a certain amount of time, the master should try resending the message.

### ◆ Response Messages from Drive to Master

If the drive receives a command from the master, it will process the data received and wait for the time set in H5-06 until it responds. Increase H5-06 if the drive response causes overrun in the master.



**Figure C.8 Minimum Response Wait Time**

## C.7 Message Format

### ◆ Message Content

In MEMOBUS/Modbus communications, the master sends commands to the slave, and the slave responds. The message format is configured for both sending and receiving as shown below, and the length of data packets depends on the command (function) content.

SLAVE ADDRESS
FUNCTION CODE
DATA
ERROR CHECK

### ◆ Slave Address

The slave address in the message defines the note the message is sent to. Use addresses between 0 and FF (hex). If a message with slave address 0 is sent (broadcast), the command from the master will be received by all slaves. The slaves do not provide a response to a broadcast type message.

### ◆ Function Code

The three types of function codes are shown in the table below.

Function Code	Function Name	Data Length (bytes)			
		Command Message		Response Message	
		Minimum	Maximum	Minimum	Maximum
03H	Read MEMOBUS/Modbus registers	8	8	7	37
08H	Loopback test	8	8	8	8
10H	Write to multiple MEMOBUS/Modbus registers	11	41	8	8

### ◆ Data

Configure consecutive data by combining the MEMOBUS/Modbus register address (test code in case of a loopback test) and the data the register contains. The data length changes depending on the command details.

A drive MEMOBUS/Modbus register always has a data length of two bytes. Therefore data written into drive registers must also always have a length of two bytes. Register data read out from the drive will always consist of two bytes.

### ◆ Error Check

The drive uses a CRC-16 (cyclic redundancy check, checksum method) for checking data validity. Use the procedure described below when calculating the CRC-16 checksum for command data or when verifying response data.

#### ■ Command Data

When the drive receives data, it calculates the CRC-16 checksum from the data and compares it to the CRC-16 value received within the message. Both must match before a command is processed.

An initial value of FFFFH (i.e., all 16 bits equal 1) must be used for CRC-16 calculations in the MEMOBUS/Modbus protocol.

Calculate the CRC-16 checksum using the following steps:

1. The starting value is FFFFH.
2. Perform an XOR operation of this value and the slave address.
3. Right shift the result.
4. When the overflow bit of the shift operation becomes 1, perform an XOR operation of the result from step 3 above and the fix value A001H.
5. Repeat steps 3 and 4 until eight shift operations have been performed.
6. After eight shift operations, perform an XOR operation with the result and the next data in the message (function code, register address, data). Continue with steps 3 to 5 until the last data has been processed.
7. The result of the last shift or XOR operation is the checksum.

## C.7 Message Format

The example in [Table C.3](#) shows the CRC-16 calculation of the slave address 02H and the function code 03H, yielding the result 40D1H.

**Note:** This example does not show the calculation for a complete MEMOBUS/Modbus command. Normally data would follow in the calculation.

**Table C.3 CRC-16 Checksum Calculation Example**

Description	Calculation	Overflow	Description	Calculation	Overflow
Initial Value (FFFFH)	1111 1111 1111 1111		Function Code 03H	0000 0000 0000 0011	
Address 02H	0000 0000 0000 0010		XOR w result	1000 0001 0011 1101	
XOR w initial value	1111 1111 1111 1101		Shift 1	0100 0000 1001 1110	1
Shift 1	0111 1111 1111 1110	1	XOR w A001H	1010 0000 0000 0001	
XOR w A001H	1010 0000 0000 0001		XOR result	1110 0000 1001 1111	
XOR result	1101 1111 1111 1111		Shift 2	0111 0000 0100 1111	1
Shift 2	0110 1111 1111 1111	1	XOR w A001H	1010 0000 0000 0001	
XOR w A001H	1010 0000 0000 0001		XOR result	1101 0000 0100 1110	
XOR result	1100 1111 1111 1110		Shift 3	0110 1000 0010 0111	0
Shift 3	0110 0111 1111 1111	0	Shift 4	0011 0100 0001 0011	1
Shift 4	0011 0011 1111 1111	1	XOR w A001H	1010 0000 0000 0001	
XOR w A001H	1010 0000 0000 0001		XOR result	1001 0100 0001 0010	
XOR result	1001 0011 1111 1110		Shift 5	0100 1010 0000 1001	0
Shift 5	0100 1001 1111 1111	0	Shift 6	0010 0101 0000 0100	1
Shift 6	0010 0100 1111 1111	1	XOR w A001H	1010 0000 0000 0001	
XOR w A001H	1010 0000 0000 0001		XOR result	1000 0101 0000 0101	
XOR result	1000 0100 1111 1110		Shift 7	0100 0010 1000 0010	1
Shift 7	0100 0010 0111 1111	0	XOR w A001H	1010 0000 0000 0001	
XOR w A001H	1010 0000 0000 0001		XOR result	1110 0010 1000 0011	
XOR result	1001 0001 0011 1110		Shift 8	0111 0001 0100 0001	1
Shift 8	0010 0001 0011 1110	1	XOR w A001H	1010 0000 0000 0001	
XOR w A001H	1010 0000 0000 0001		XOR result	1101 0001 0100 0000	
XOR result	1000 0001 0011 1110			1101 0001 0100 0000	
Perform operations with next data (function code)			XOR result	1101 0001 0100 0000	
			CRC-16	1101 0001 0100 0000	
				D140H	
Continue from here with next data.					

### ■ Response Data

To be sure that the data is valid, perform a CRC-16 calculation on the response message data as described above. Compare the result to the CRC-16 checksum that was received within the response message. Both should match.

## C.8 Message Examples

Below are some examples of command and response messages.

### ◆ Reading Drive MEMOBUS/Modbus Register Contents

Using the function code 03H (Read), a maximum of 16 MEMOBUS/Modbus registers can be read out at a time.

The following table shows message examples when reading status signals, error details, data link status, and frequency references from the slave 2 drive.

Command Message			Response Message (normal)			Response Message (fault)		
Slave Address		02H	Slave Address		02H	Slave Address		02H
Function Code		03H	Function Code		03H	Function Code		83H
Starting No.	Upper	00H	Data Quantity		08H	Error Code		03H
	Lower	20H	1st storage register	Upper	00H	CRC-16	Upper	F1H
Data Quantity	Upper	00H		Lower	65H		Lower	31H
	CRC-16	Lower	04H	Next storage register	Upper	00H		
Upper		45H	Lower		00H			
CRC-16	Lower	FOH	Next storage register	Upper	00H			
				Lower	00H			
			Next storage register	Upper	01H			
				Lower	F4H			
			CRC-16	Upper	AFH			
				Lower	82H			

### ◆ Loopback Test

Function code 08H performs a loopback test. This test returns a response message with exactly the same content as the command message and can be used to check communications between the master and slave. User-defined test code and data values can be set.

The following table shows a message example when performing a loopback test with the slave 1 drive.

Command Message			Response Message (normal)			Response Message (fault)		
Slave Address		01H	Slave Address		01H	Slave Address		01H
Function Code		08H	Function Code		08H	Function Code		89H
Test Code	Upper	00H	Test Code	Upper	00H	Error Code		01H
	Lower	00H		Lower	00H	CRC-16	Upper	86H
Data	Upper	A5H	Data	Upper	A5H		Lower	50H
	Lower	37H		Lower	37H			
CRC-16	Upper	DAH	CRC-16	Upper	DAH			
	Lower	8DH		Lower	8DH			

### ◆ Writing to Multiple Registers

Function code 10h allows the user to write multiple drive MEMOBUS/Modbus registers with one message. This process works similar to reading registers, i.e., the address of the first register that is to be written and the data quantity must be set in the command message. The data to be written must be consecutive so that the register addresses are in order, starting from the specified address in the command message. The data order must be high byte, then lower byte.

The following table shows an example of a message where a forward operation has been set with a frequency reference of 60.0 Hz for the slave 1 drive.

If parameter values are changed using the Write command, depending on the setting of H5-11, an Enter command will be necessary to activate the data or save them. [Refer to H5-11: Communications Enter Function Selection on page 418](#) and [Refer to Enter Command on page 434](#) for detailed descriptions.

Command Message			Response Message (normal)			Response Message (fault)		
Slave Address		01H	Slave Address		01H	Slave Address		01H
Function Code		10H	Function Code		10H	Function Code		90H
Starting No.	Upper	00H	Starting No.	Upper	00H	Error Code		02H
	Lower	01H		Lower	01H		CRC-16	Upper
Data Quantity	Upper	00H	Data Quantity	Upper	00H	Lower		C1H
	Lower	02H		Lower	02H			
Number of Bytes		04H	CRC-16	Upper	10H			
Starting Data	Upper	00H		Lower	08H			
	Next Data	Upper	02H					
CRC-16		Lower	58H					
	Upper	63H						
Lower	39H							

**Note:** For the number of bytes in the command message, take double the number of the data quantity.



## C.9 MEMOBUS/Modbus Data Table

Table below lists all MEMOBUS/Modbus data. There are three types of data: command data, monitor data, and broadcast data.

### ◆ Command Data

It is possible to both read and write command data.

**Note:** Bits that are not used should be set to 0. Refrain from writing to reserved registers.

Register No.	Contents	
0000H	Reserved	
0001H	Operation Commands and Multi-function Inputs	
	bit 0	H5-12 = 0: Forward Run Command (0 = Stop, 1 = Forward Run) H5-12 = 1: Run Command (0 = Stop, 1 = Run)
	bit 1	H5-12 = 0: Reverse Run Command (0 = Stop, 1 = Reverse Run) H5-12 = 1: Forward/Reverse (0 = Forward, 1 = Reverse)
	bit 2	External Fault (EF0)
	bit 3	Fault Reset
	bit 4	Multi-Function Input 1 Function is ComRef when H1-01 = 40 (Forward/Stop). <i>Refer to d: Reference Settings on page 165</i> for ComRef explanations.
	bit 5	Multi-Function Input 2 Function is ComCtrl when H1-02 = 41 (Reverse/Stop). <i>Refer to d: Reference Settings on page 165</i> for ComCtrl explanations.
	bit 6	Multi-Function Input 3
	bit 7	Multi-Function Input 4
	bit 8	Multi-Function Input 5
	bit 9	Multi-Function Input 6
	bit A	Multi-Function Input 7
	bit B	Multi-Function Input 8
	bit C to bit F	Reserved
0002H	Frequency Reference	Units are determined by parameter o1-03.
0003H	V/f Gain	
0004H-0005H	Reserved	
0006H	PI Target, 0.01% units, signed	
0007H	Analog Output Terminal FM Setting (10 V / 4000 H)	
0008H	Analog Output Terminal AM Setting (10 V / 4000 H)	
0009H	Settings for Multi-Function Digital Outputs	
	bit 0	Multi-Function Contact Output 1 (terminal M1-M2)
	bit 1	Multi-Function Contact Output 2 (terminal M3-M4)
	bit 2	Multi-Function Contact Output 3 (terminal M5-M6)
	bit 3 to bit 5	Reserved
	bit 6	Enables the function in bit 7
	bit 7	Fault Contact Output (terminal MA/MB-MC)
bit 8 to F	Reserved	
000AH	Pulse Output Terminal MP Setting, 1 Hz units, Setting Range: 0 to 32000	
000BH to 000EH	Reserved	
000FH	Control Selection Setting	
	bit 0	Reserved
	bit 1	PI Setpoint Input
	bit 2 to bit B	Reserved
	bit C	Enable Terminal S5 Input for Broadcast Data
	bit D	Enable Terminal S6 Input for Broadcast Data
	bit E	Enable Terminal S7 Input for Broadcast Data
bit F	Enable Terminal S8 Input for Broadcast Data	
0010H to 001FH	Reserved	

## C.9 MEMOBUS/Modbus Data Table

### ◆ Monitor Data

Monitor data can be read only.

Register No.	Contents	
0020H	Drive Status 1	
	bit 0	During Run
	bit 1	During Reverse
	bit 2	Drive Ready
	bit 3	Fault
	bit 4	Data Setting Error
	bit 5	Multi-Function Contact Output 1 (terminal M1-M2)
	bit 6	Multi-Function Contact Output 2 (terminal M3-M4)
	bit 7	Multi-Function Contact Output 3 (terminal M5-M6)
	bit 8 to bit D	Reserved
bit E	ComRef status	
bit F	ComCtrl status	
0021H	Fault Contents 1	
	bit 0	Overcurrent (oC), Ground fault (GF)
	bit 1	Overvoltage (ov)
	bit 2	Drive Overload (oL2)
	bit 3	Overheat 1 (oH1), Drive Overheat Warning (oH2)
	bit 4 to bit 5	Reserved
	bit 6	PI Feedback Loss (FbL / FbH)
	bit 7	EF to EF8: External Fault
	bit 8	CPF□□: Hardware Fault (includes oFx)
	bit 9	Motor Overload (oL1), Overtorque Detection 1 (oL3), Undertorque Detection 1 (UL3)
	bit A	Reserved
	bit B	Main Circuit Undervoltage (Uv)
	bit C	Undervoltage (Uv1), Control Power Supply Undervoltage (Uv2), Soft Charge Circuit Fault (Uv3)
	bit D	Output Phase Loss (LF), Input Phase Loss (PF)
bit E	MEMOBUS/Modbus Communication Error (CE), Option Communication Error (bUS)	
bit F	Operator Connection Fault (oPr)	
0022H	Data Link Status	
	bit 0	Writing data or switching motors
	bit 1	Reserved
	bit 2	
	bit 3	Upper or lower limit error
	bit 4	Data conformity error
	bit 5	Writing to EEPROM
	bit 6 to bit F	Reserved
0023H	Frequency Reference, <f>	
0024H	Output Frequency, <f>	
0025H	Output Voltage Reference, 0.1 V units (units are determined by parameter H5-10)	
0026H	Output Current, 0.1 A units	
0027H	Output Power	
0028H	Reserved	
0029H	Fault Contents 2	
	bit 0	IGBT Short Circuit (SC)
	bit 1	Ground Fault (GF)
	bit 2	Input Phase Loss (PF)
	bit 3	Output Phase Loss (LF)
	bit 4 to bit 5	Reserved
	bit 6	Motor Overheat 2 (PTC input) (oH4)
	bit 7 to bit F	Reserved

Register No.	Contents	
002AH	Alarm Contents1	
	bit 0, 1	Reserved
	bit 2	Run Command Input Error (EF)
	bit 3	Drive Baseblock (bb)
	bit 4	Overtorque Detection 1 (oL3)
	bit 5	Heatsink Overheat (oH)
	bit 6	Overvoltage (ov)
	bit 7	Undervoltage (Uv)
	bit 8	Cooling Fan Error (FAn)
	bit 9	MEMOBUS/Modbus Communication Error (CE)
	bit A	Option Communication Error (bUS)
	bit B	Undertorque Detection 1 (UL3)
	bit C	Motor Overheat (oH3)
	bit D	PI Feedback Loss (FbL, FbH)
	bit E	Reserved
bit F	Serial Communication Transmission Error (CALL)	
002BH	Input Terminal Status	
	bit 0	Terminal S1 Closed
	bit 1	Terminal S2 Closed
	bit 2	Terminal S3 Closed
	bit 3	Terminal S4 Closed
	bit 4	Terminal S5 Closed
	bit 5	Terminal S6 Closed
	bit 6	Terminal S7 Closed
	bit 7	Terminal S8 Closed
bit 8 to bit F	Reserved	
002CH	Drive Status 2	
	bit 0	During Run
	bit 1	Zero Speed
	bit 2	Speed Agree
	bit 3	User Speed Agree
	bit 4	Frequency Detection 1
	bit 5	Frequency Detection 2
	bit 6	Drive Ready
	bit 7	During Undervoltage
	bit 8	During Baseblock
	bit 9	Frequency Reference from Operator Keypad
	bit A	Run Command from Operator Keypad
	bit B	Over/Undertorque 1
	bit C	Frequency Reference Loss
	bit D	During Fault Restart
bit E	Fault	
bit F	Communication Timeout	
002DH	Output Terminal Status	
	bit 0	Multi-Function Contact Output 1 (terminal M1-M2)
	bit 1	Multi-Function Contact Output 2 (terminal M3-M4)
	bit 2	Multi-Function Contact Output 3 (terminal M5-M6)
	bit 3 to 6	Reserved
	bit 7	Fault Contact Output (terminal MA/MB-MC)
	bit 8 to F	Reserved
002EH-0030H	Reserved	
0031H	DC Bus Voltage, 1 Vdc units	
0032H, 0033H	Reserved	
0034H	Product Code 1 [ASCII], Product Type (A0 for E1000)	
0035H	Product Code 2 [ASCII], Region Code	
0036H, 0037H	Reserved	
0038H	PI Feedback, 0.1% units, unsigned, 100% / max. output frequency	
0039H	PI Input, 0.1% units, signed, 100% / max. output frequency	
003AH	PI Output, 0.1% units, signed, 100% / max. output frequency	
003BH, 003CH	Reserved	
003DH	Communications Error Contents <->	
	bit 0	CRC Error
	bit 1	Data Length Error
	bit 2	Reserved
	bit 3	Parity Error
	bit 4	Overrun Error
	bit 5	Framing Error
	bit 6	Timeout
bit 7 to bit F	Reserved	

## C.9 MEMOBUS/Modbus Data Table

Register No.	Contents		
003EH	Output Frequency	r/min <4>	
003FH		0.01% units	
0040H to 004AH	Used for various monitors U1-□□. <a href="#">Refer to U: Monitors on page 391</a> for parameter details.		
004BH	Drive status (U1-12)		
	bit 0	During Run	
	bit 1	During Zero Speed	
	bit 2	During Reverse Run	
	bit 3	During Fault Reset Signal Input	
	bit 4	During Speed Agree	
	bit 5	Drive Ready	
	bit 6	Alarm	
	bit 7	Fault	
	bit 8	During Operation Error (oPE□□)	
	bit 9	During Momentary Power Loss	
	bit A to bit B	Reserved	
	bit E	ComRef status, NetRef status	
bit F	ComCtrl status, NetCtrl status		
004CH to 007EH	Used for various monitors U1-□□, U4-□□, U5-□□ and U6-□□. <a href="#">Refer to U: Monitors on page 391</a> for parameter details.		
007FH	Alarm Code. <a href="#">Refer to Alarm Register Contents on page 433</a> for alarm codes.		
0080H to 0097H	Used for monitors U2-□□, U3-□□. <a href="#">Refer to U: Monitors on page 391</a> for parameter details and <a href="#">Refer to Fault Trace Contents on page 432</a> for register value descriptions.		
0098H	High Word of Accumulated Operation Time Monitor, 10H units (U4-01)		
0099H	Low Word of Accumulated Operation Time Monitor, 1H units (U4-01)		
009AH	High Word of Cooling Fan Operation Time Monitor (U4-03)		
009BH	Low Word of Cooling Fan Operation Time Monitor (U4-03)		
009CH to 00AAH	Reserved		
00ABH	Drive Rated Current <2>		
00AEH, 00AFH	Reserved		
00B0H	Option Code Connected to CN5-A	Communication Option: Register contains ASCII code of 1st and 3rd digit of the option card type number. Example: Register value is 5343H for "SC" if a SI-C3 option card is installed.	
00B1H-00B4H	Reserved		
00B5H	Frequency Reference After Soft-starter (U1-16)	r/min units <4>	
00B6H		0.01% units	
00B7H	Frequency Reference	r/min <4>	
00B8H		0.01% units	
00B9H to 00BEH	Reserved		
00BFH	Lists the last to digits of operation error code oPE□□.		
00C0H	Fault contents 3		
	bit 1	Undervoltage (Uv1)	
	bit 2	Control Power Supply Undervoltage (Uv2)	
	bit 3	Soft Charge Circuit Fault (Uv3)	
	bit 4	IGBT Short Circuit (SC)	
	bit 5	Ground Fault (GF)	
	bit 6	Overcurrent (oC)	
	bit 7	Overvoltage (ov)	
	bit 8	Heatsink Overheat (oH)	
	bit 9	Heatsink Overheat (oH1)	
	bit A	Motor Overload (oL1)	
	bit B	Drive Overload (oL2)	
	bit C	Overtorque Detection 1 (oL3)	
bit D to F	Reserved		
00C1H	Fault contents 4		
	bit 0	External Fault at input terminal S3 (EF3)	
	bit 1	External Fault at input terminal S4 (EF4)	
	bit 2	External Fault at input terminal S5 (EF5)	
	bit 3	External Fault at input terminal S6 (EF6)	
	bit 4	External Fault at input terminal S7 (EF7)	
	bit 5	External Fault at input terminal S8 (EF8)	
	bit 6	Cooling Fan Error (FAn)	
	bit 7 to bit 9	Reserved	
	bit A	Input Phase Loss (PF)	
	bit B	Output Phase Loss (LF)	
	bit C	Motor Overheat (PTC input) (oH3)	
	bit D	Digital Operator Connection Fault (oPr)	
bit E	EEPROM Write Error (Err)		
bit F	Motor Overheat Fault (PTC input) (oH4)		

Register No.	Contents	
00C2H	Fault contents 5	
	bit 0	MEMOBUS/Modbus Communication Error (CE)
	bit 1	Option Communication Error (bUS)
	bit 2 to bit 5	Reserved
	bit 6	Option External Fault (EF0)
	bit 7	PI Feedback Loss (FbL)
	bit 8	Undertorque Detection 1 (UL3)
	bit 9	Reserved
	bit A	High Slip Braking Overload (oL7)
	bit B to E	Reserved
	bit F	Hardware Fault (includes oFx)
00C3H	Fault contents 6	
	bit 0 to bit 4	Reserved
	bit 5	Current Imbalance (LF2)
	bit 6	Pullout Detection (STo)
	bit 7	Reserved
	bit 8	SI-T3 Watchdog Error (E5)
	bit 9	Reserved
	bit A	Too many speed search restarts (SEr)
	bit B to F	Reserved
00C4H	Fault contents 7	
	bit 0	PI Feedback Loss (FbH)
	bit 1	External Fault 1, input terminal S1 (EF1)
	bit 2	External Fault 2, input terminal S2 (EF2)
	bit 3 to bit 4	Reserved
	bit 5	Current Offset Fault (CoF)
	bit 6, 7	Reserved
	bit 8	DriveWorksEZ Fault (dWFL)
	bit 9 to bit B	Reserved
	bit C	Output Voltage Detection Fault (voF)
	bit D	Braking Resistor Fault (rF)
bit E	Braking Transistor Overload Fault (boL)	
bit F	Motor Overheat (NTC Input) (oH5)	
00C5H	Fault contents 8	
	bit 0	Reserved
	bit 1	Node Setup Fault (nSE)
	bit 2	Thermistor Disconnect (THo)
	bit 3 to 8	Reserved
	bit 9	Underload Detection 6 (UL6)
	bit A	Polarity Judge Timeout (dv7)
	bit B to D	Reserved
	bit E	Power Unit Output Phase Loss 3 (LF3)
bit F	Current Unbalance (UnbC)	
00C6H	Fault contents 9	
	bit 0	Gate Drive Board Undervoltage (Uv4)
	bit 1 to F	Reserved
00C7H	Reserved	
00C8H	Alarm contents 2	
	bit 0	Undervoltage (Uv)
	bit 1	Overvoltage (ov)
	bit 2	Heatsink Overheat (oH)
	bit 3	Drive Overheat (oH2)
	bit 4	Overtorque 1 (oL3)
	bit 5	Reserved
	bit 6	Run Commands Input Error (EF)
	bit 7	Drive Baseblock (bb)
	bit 8	External Fault 3, input terminal S3 (EF3)
	bit 9	External Fault 4, input terminal S4 (EF4)
	bit A	External Fault 5, input terminal S5 (EF5)
	bit B	External Fault 6, input terminal S6 (EF6)
	bit C	External Fault 7, input terminal S7 (EF7)
	bit D	External Fault 8, input terminal S8 (EF8)
bit E	Cooling Fan Error (FAn)	
bit F	Reserved	

## C.9 MEMOBUS/Modbus Data Table

Register No.	Contents	
00C9H	Alarm contents 3	
	bit 0 to bit 1	Reserved
	bit 2	Digital Operator Connection Fault (oPr)
	bit 3	MEMOBUS/Modbus Communication Error (CE)
	bit 4	Option Communication Error (bUS)
	bit 5	Serial Communication Transmission Error (CALL)
	bit 6	Motor Overload (oL1)
	bit 7	Drive Overload (oL2)
	bit 8	Reserved
	bit 9	Option Card External fault (EF0)
	bit A to bit B	Reserved
	bit C	Serial Communication Transmission Error (CALL)
	bit D	Undertorque Detection 1 (UL3)
	bit E	Reserved
bit F	MEMOBUS/Modbus Test Mode Fault (SE)	
00CAH	Alarm contents 4	
	bit 0	Reserved
	bit 1	Motor Overheat 1 (PTC Input) (oH3)
	bit 2 to 5	Reserved
	bit 6	PI Feedback Loss (FbL)
	bit 7	PI Feedback Loss (FbH)
	bit 9	Drive Disabled (dnE)
	bit A to bit F	Reserved
00CBH	Alarm Contents 5	
	bit 0	SI-T3 Watchdog Error (E5)
	bit 1	SI-T3 Station Address Setting Error (AEr)
	bit 2	SI-T3 Comm. Cycle Setting Error (CyC)
	bit 3	High Current Alarm (HCA)
	bit 4	Cooling Fan Maintenance Time (LT-1)
	bit 5	Soft Charge Bypass Relay Maintenance Time (LT-2)
	bit 6	Reserved
	bit 7	SI-S EEPROM Error (EEP)
	bit 8	External Fault 1 (input terminal S1) (EF1)
	bit 9	External Fault 2 (input terminal S2) (EF2)
bit A to bit F	Reserved	
00CCH	Alarm Contents 6	
	bit 0	Output Voltage Detection Fault (VoF)
	bit 1	IGBT Maintenance Time (90%) (TrPC)
	bit 2	Capacitor Maintenance Time (LT-3)
	bit 3	IGBT Maintenance Time (50%) (LT-4)
	bit 4	Braking Transistor Overload Fault (boL)
	bit 5 to 6	Reserved
	bit 7	Motor Overheat (NTC Input) (oH5)
	bit 8	DriveWorksEZ Alarm (dWAL)
	bit 9 to B	Reserved
	bit C	Thermistor Disconnect (THo)
	bit D	Underload Detection 6 (UL6)
	bit E	Waiting for RUN (WrUn)
	bit F	Reserved
00CDH to 00CFH	Reserved	
00D0H	CPF Contents 1	
	bit 0, 1	Reserved
	bit 2	A/D Conversion Error (CPF02)
	bit 3	PWM Data Fault (CPF03)
	bit 4, 5	Reserved
	bit 6	EEPROM Memory Data Error (CPF06)
	bit 7	Terminal Board Connection Error (CPF07)
	bit 8	EEPROM Serial Communications Fault (CPF08)
	bit 9, A	Reserved
	bit B	RAM Fault (CPF11)
	bit C	FLASH Memory Fault (CPF12)
	bit D	Watchdog Circuit Exception (CPF13)
	bit E	Control Circuit Fault (CPF14)
	bit F	Reserved

Register No.	Contents	
00D1H	CPF Contents 2	
	bit 0	Clock Fault (CPF16)
	bit 1	Timing Fault (CPF17)
	bit 2	Control Circuit Fault (CPF18)
	bit 3	Control Circuit Fault (CPF19)
	bit 4	Hardware fault at power up (CPF20)
	bit 5	Hardware fault at communication start up (CPF21)
	bit 6	A/D Conversion Fault (CPF22)
	bit 7	PWM Feedback Fault (CPF23)
	bit 8	Drive Unit Signal Fault (CPF24)
	bit 9	Terminal board is not properly connected. (CPF25)
	bit A	ASIC BB Circuit Error (CPF26)
	bit B	ASIC PWM Setting Register Error (CPF27)
	bit C	ASIC PWM Pattern Error (CPF28)
	bit D	ASIC On-delay Error (CPF29)
	bit E	ASIC BBON Error (CPF30)
bit F	ASIC Code Error (CPF31)	
00D2H	bit 0	ASIC Start-up Error (CPF32)
	bit 1	Watch-dog Error (CPF33)
	bit 2	ASIC Power/Clock Error (CPF34)
	bit 3	External A/D Converter Error (CPF35)
	bit 4 to 7	Reserved
	bit 8	Control Circuit Error (CPF40)
	bit 9	Control Circuit Error (CPF41)
	bit A	Control Circuit Error (CPF42)
	bit B	Control Circuit Error (CPF43)
	bit C	Control Circuit Error (CPF44)
bit D	Control Circuit Error (CPF45)	
bit E, F	Reserved	
00D3H to 00D7H	oFA0x Contents (CN5-A)	
00D8H	oFA0x Contents (CN5-A)	
	bit 0	Option Compatibility Error (oFA00)
	bit 1	Option not properly connected (oFA01)
	bit 2	Same type of option card already connected (oFA02)
	bit 3, 4	Reserved
	bit 5	A/D Conversion Error (oFA05)
	bit 6	Option Response Error (oFA06)
	bit 7 to F	Reserved
00D9H	oFA1x Contents (CN5-A)	
	bit 0	Option RAM Fault (oFA10)
	bit 1	Option Operation Mode Fault (SLMOD) (oFA11)
	bit 2	Drive Receive CRC Error (oFA12)
	bit 3	Drive Receive Frame Error (oFA13)
	bit 4	Drive Receive Abort Error (oFA14)
	bit 5	Option Receive CRC Error (oFA15)
	bit 6	Option Receive Frame Error (oFA16)
	bit 7	Option Receive Abort Error (oFA17)
bit 8 to F	Reserved	
00DAH to 00DBH	Reserved	
00DBH	oFA3x Contents (CN5-A)	
	bit 0	Comm. ID Error (oFA30)
	bit 1	Model Code Error (oFA31)
	bit 2	Sumcheck Error (oFA32)
	bit 3	Comm. option timeout waiting for response (oFA33)
	bit 4	MEMOBUS Timeout (oFA34)
	bit 5	Drive timeout waiting for response (oFA35)
	bit 6	CI Check Error (oFA36)
	bit 7	Drive timeout waiting for response (oFA37)
	bit 8	Control Command Selection Error (oFA38)
	bit 9	Drive timeout waiting for response (oFA39)
	bit A	Control Response Selection 1 Error (oFA40)
	bit B	Drive timeout waiting for response (oFA41)
	bit C	Control Response Selection 2 Error (oFA42)
	bit D	Control Response Selection Error (oFA43)
bit E, F	Reserved	
00DCH to 00FFH	Reserved	

<1> Units are determined by parameter o1-03.

## C.9 MEMOBUS/Modbus Data Table

- <2> This value's number of decimal places depends on the drive model. The value will have two decimal places (0.01 A) if the drive model is CIMR-E□2A0004 to 2A0040, 4A0002 to 4A0023 and one decimal place (0.1 A) if the drive model is CIMR-E□2A0056 to 2A0415, 4A0031 to 4A1200.
- <3> The contents of a communication error are saved until the fault is reset.
- <4> Depending on the motor used, the correct motor pole number must be set to parameter E2-04 or E5-05.

### ◆ Broadcast Messages

Data can be written from the master to all slave devices at the same time.

The slave address in a broadcast command message must be set to 00H. All slaves will receive the message, but will not respond.

Register No.	Contents	
0001H	Digital Input Command	
	bit 0	Forward Run (0: Stop 1: Run)
	bit 1	Direction Command (0: Forward, 1: Reverse)
	bit 2, 3	Reserved
	bit 4	External Fault
	bit 5	Fault Reset
	bit 6 to B	Reserved
	bit C	Multi-Function Digital Input S5
	bit D	Multi-Function Digital Input S6
	bit E	Multi-Function Digital Input S7
	bit F	Multi-Function Digital Input S8
0002H	Frequency Reference	30000/100%

### ◆ Fault Trace Contents

The table below shows the fault codes that can be read out by MEMOBUS/Modbus commands from the U2-□□ monitor parameters.

**Table C.4 Fault Trace / History Register Contents**

Fault Code	Fault Name	Fault Code	Fault Name
0002H	Undervoltage (Uv1)	008DH	Flash Memory Circuit Exception (CPF12)
0003H	Control Power Supply Undervoltage (Uv2)	008EH	Watchdog Circuit Exception (CPF13)
0004H	Soft Charge Circuit Fault (Uv3)	008FH	Control Circuit Fault (CPF14)
0005H	IGBT Short Circuit (SC)	0091H	Clock Fault (CPF16)
0006H	Ground Fault (GF)	0092H	Timing Fault (CPF17)
0007H	Overcurrent (oC)	0093H	Control Circuit Fault (CPF18)
0008H	Overvoltage (ov)	0094H	Control Circuit Fault (CPF19)
0009H	Heatsink Overheat (oH)	0095H	Hardware fault at power up (CPF20)
000AH	Heatsink Overheat (oH1)	0096H	Hardware fault at communication start up (CPF21)
000BH	Motor Overload (oL1)	0097H	A/D Conversion Fault (CPF22)
000CH	Drive Overload (oL2)	0098H	PWM Feedback Fault (CPF23)
000DH	Overtorque Detection 1 (oL3)	0099H	Drive Unit Signal Fault (CPF24)
0011H	External Fault at input terminal S3 (EF3)	009AH	Terminal board is not properly connected. (CPF25)
0012H	External Fault at input terminal S4 (EF4)	009BH	ASIC BB Circuit Error (CPF26)
0013H	External Fault at input terminal S5 (EF5)	009CH	ASIC PWM Setting Register Error (CPF27)
0014H	External Fault at input terminal S6 (EF6)	009DH	ASIC PWM Pattern Error (CPF28)
0015H	External Fault at input terminal S7 (EF7)	009EH	ASIC On-Delay Error (CPF29)
0016H	External Fault at input terminal S8 (EF8)	009FH	ASIC BBON Error (CPF30)
001BH	Input Phase Loss (PF)	00A0H	ASIC Code Error (CPF31)
001CH	Output Phase Loss (LF)	00A1H	ASIC Start-p Error (CPF32)
001DH	Motor Overheat (PTC input) (oH3)	00A2H	Watch-dog Error (CPF33)
001EH	Digital Operator Connection (oPr)	00A3H	ASIC Power/Clock Error (CPF34)
001FH	EEPROM Write Error (Err)	00A4H	External A/D Converter Error (CPF35)
0020H	Motor Overheat (PTC input) (oH4)	00A9H	Control Circuit Error (CPF40)
0021H	MEMOBUS/Modbus Communication Error (CE)	00AAH	Control Circuit Error (CPF41)
0022H	Option Communication Error (bUS)	00ABH	Control Circuit Error (CPF42)
0025H	Control fault (CF)	00ACH	Control Circuit Error (CPF43)
0027H	Option External Fault (EF0)	00ADH	Control Circuit Error (CPF44)
0028H	PI Feedback Loss (FbL)	00AEH	Control Circuit Error (CPF45)
0029H	Undertorque Detection 1 (UL3)	0101H	Option compatibility error (oFA00)
002BH	High Slip Braking Overload (oL7)	0102H	Option not properly connected (oFA01)
0030H	Hardware Fault (including oFx)	0103H	Same type of option card already connected (oFA02)



Fault Code	Fault Name	Fault Code	Fault Name
0036H	Output Current Imbalance (LF2)	0106H	A/D Conversion Error (oFA05)
0037H	Pullout Detection (Sto)	0107H	Option Response Error (oFA06)
003BH	Too many speed search restarts (SEr)	0111H	Option RAM Fault (oFA10)
0041H	PI Feedback Loss (FbH)	0112H	Option Operation Mode Fault (SLMOD) (oFA11)
0042H	External Fault 1, input terminal S1 (EF1)	0113H	Drive Receive CRC Error (oFA12)
0043H	External Fault 2, input terminal S2 (EF2)	0114H	Drive Receive Frame Error (oFA13)
0046H	Current Offset Fault (CoF)	0115H	Drive Receive Abort Error (oFA14)
0047H	PLC Detection Error 1 (PE1)	0116H	Option Receive CRC Error (oFA15)
0048H	PLC Detection Error 2 (PE2)	0117H	Option Receive Frame Error (oFA16)
0049H	DriveWorksEZ Fault (dWFL)	0118H	Option Receive Abort Error (oFA17)
004DH	Output Voltage Detection Fault (voF)	0131H	Comm. ID Error (oFA30)
0050H	Motor Overheat (NTC Input) (oH5)	0132H	Model Code Error (oFA31)
0052H	Node Setup Fault (nSE)	0133H	Checksum Error (oFA32)
0053H	Thermistor Disconnect (THo)	0134H	Comm. option timeout waiting for response (oFA33)
005AH	Motor Underload (UL6)	0135H	MEMOBUS Timeout (oFA34)
005BH	Polarity Judge Timeout (dV7)	0136H	Drive timeout waiting for response (oFA35)
005FH	Power Unit Output Phase Loss 3 (LF3)	0137H	CI Check Error (oFA36)
0060H	Current Unbalance (UnbC)	0138H	Drive timeout waiting for response (oFA37)
0061H	Power Supply Module Undervoltage (Uv4)	0139H	Control Command Selection Error (oFA38)
0083H	A/D Conversion Error (CPF02)	013AH	Drive timeout waiting for response (oFA39)
0084H	PWM Data Fault (CPF03)	013BH	Control Response Selection 1 Error (oFA40)
0087H	EEPROM Memory Data Error (CPF06)	013CH	Drive timeout waiting for response (oFA41)
0088H	Terminal Board Connection Error (CPF07)	013DH	Control Response Selection 2 Error (oFA42)
0089H	EEPROM Serial Communication Fault (CPF08)	013EH	Control Response Selection Error (oFA43)
008CH	RAM Fault (CPF11)	-	-

## ◆ Alarm Register Contents

The table below shows the alarm codes that can be read out from MEMOBUS/Modbus register 007FH.

**Table C.5 Alarm Register 007FH Contents**

Alarm Code	Fault Name	Alarm Code	Fault Name
0001H	Undervoltage (Uv)	0027H	PI Feedback Loss (FbL)
0002H	Overvoltage (ov)	0028H	PI Feedback Loss (FbH)
0003H	Heatsink Overheat (oH)	002AH	Drive Disabled (dnE)
0004H	Drive Overheat (oH2)	0031H	SI-T3 Watchdog Error (E5)
0005H	Overtorque 1 (oL3)	0032H	SI-T3 Station Address Setting Error (AEr)
0007H	Run commands input error (EF)	0033H	SI-T3 Comm. Cycle Setting Error (CyC)
0008H	Drive Baseblock (bb)	0034H	High Current Alarm (HCA)
0009H	External Fault 3, input terminal S3 (EF3)	0035H	Cooling Fan Maintenance Time (LT-1)
000AH	External Fault 4, input terminal S4 (EF4)	0036H	Capacitor Maintenance Time (LT-2)
000BH	External Fault 5, input terminal S5 (EF5)	0038H	SI-S EEPROM Error (EEP)
000CH	External Fault 6, input terminal S6 (EF6)	0039H	External Fault (input terminal S1) (EF1)
000DH	External Fault 7, input terminal S7 (EF7)	003AH	External Fault (input terminal S2) (EF2)
000EH	External Fault 8, input terminal S8 (EF8)	003FH	PLC Alarm (PA1)
000FH	Cooling Fan Error (FAN)	0040H	PLC Alarm (PA2)
0014H	MEMOBUS/Modbus Communication Error (CE)	0041H	Output Voltage Detection Fault (voF)
0015H	Option Communication Error (bUS)	0042H	IGBT Maintenance Time (90%) (TrPC)
0016H	Serial Communication Transmission Error (CALL)	0043H	Soft Charge Bypass Relay Maintenance Time (LT-3)
0017H	Motor Overload (oL1)	0044H	IGBT Maintenance Time (50%) (LT-4)
0018H	Drive Overload (oL2)	0048H	Motor Overheat (NTC Input) (oH5)
001AH	Option Card External Fault (EF0)	0049H	DriveWorksEZ Alarm (dWAL)
001DH	Serial Communication Transmission Error (CALL)	004DH	Thermistor Disconnect (THo)
001EH	Undertorque Detection 1 (UL3)	004EH	Motor Underload (UL6)
0020H	MEMOBUS/Modbus Test Mode Fault (SE)	004FH	Waiting for Run (WrUn)
0022H	Motor Overheat (oH3)	-	-

## C.10 Enter Command

When writing parameters to the drive from the PLC using MEMOBUS/Modbus communication, parameter H5-11 determines if an Enter command must be issued to enable these parameters or not. This sections the types of Enter commands and how they work.

### ◆ Enter Command Types

The drive supports two types of Enter commands as shown in the table below. An Enter command is enabled by writing 0 to register number 0900H or 0910H. These registers can only be written to. An error will occur if the user attempts to read from these registers.

**Table C.6 Enter Command Types**

Register No.	Description
0900H	Writes data into the EEPROM (non-volatile memory) of the drive and enables the data in RAM at the same time. Parameter changes remain even if the power supply is cycled.
0910H	Writes data in the RAM only. Parameter changes are lost when the drive is shut off.

**Note:** Because the EEPROM can be written to a maximum of 100,000 times, refrain from writing to the EEPROM too often. The Enter command registers are write-only. Consequently, if these registers are read, then the register address will be invalid (Error code: 02H). An Enter command is not required if reference or broadcast data are sent to the drive.

### ◆ H5-11 and the Enter Command

An Enter command is not required when writing registers 0000H to 001F. Changes to those registers take effect immediately, independent of the setting in parameter H5-11.

H5-11 Settings	H5-11 = 0	H5-11 = 1
How parameter settings are enabled	When the Enter command is received from the master.	As soon as the value is changed.
Upper/lower limit check	Upper/lower limit check is performed, taking the settings of related parameters into account.	Checks only the upper/lower limits of the parameters that were changed.
Default value of related parameters	Not affected. The settings of related parameters remain unchanged. They must be changed manually if needed.	Default settings of related parameters are changed automatically.
Error handling when setting multiple parameters	Data is accepted even if one setting is invalid. The invalid setting will be discarded. No error message occurs.	Error occurs if only one setting is invalid. All data that was sent are discarded.

## C.11 Communication Errors

### ◆ MEMOBUS/Modbus Error Codes

A list of MEMOBUS/Modbus errors appears below.

When an error occurs, remove whatever caused the error and restart communications.

Error Code	Error Name
	Cause
01H	Function Code Error
	<ul style="list-style-type: none"> <li>Attempted to set a function code from a PLC other than 03H, 08H, and 10H.</li> </ul>
02H	Register Number Error
	<ul style="list-style-type: none"> <li>A register number specified in the command message does not exist.</li> <li>Attempted to send a broadcast message using other register numbers than 0001H or 0002H.</li> </ul>
03H	Bit Count Error
	<ul style="list-style-type: none"> <li>Read data or write data is greater than 16 bits. Invalid command message quantity.</li> <li>In a write message, the "Number of Data Items" contained within the message does not equal twice the amount of data words (i.e., the total of Data 1+ Data 2, etc.).</li> </ul>
21H	Data Setting Error
	<ul style="list-style-type: none"> <li>Control data or parameter write data is outside the allowable setting range.</li> <li>Attempted to write a contradictory parameter setting.</li> </ul>
22H	Write Mode Error
	<ul style="list-style-type: none"> <li>During run, the user attempted to write a parameter that cannot be written to during run.</li> <li>During an EEPROM memory data error (CPF06), the master attempted to write to a parameter other than A1-00 to A1-05, E1-03, or o2-04.</li> <li>Attempted to write to read-only data.</li> </ul>
23H	DC Bus Undervoltage Write Error
	<ul style="list-style-type: none"> <li>During an undervoltage situation, the master attempted to write to parameters that cannot be written to during undervoltage.</li> </ul>
24H	Write Error During Parameter Process
	<ul style="list-style-type: none"> <li>Master attempted writing to the drive while the drive was processing parameter data.</li> </ul>

### ◆ Slave Not Responding

In the following situations, the slave drive will ignore the command message sent from the master, and not send a response message:

- When a communications error (overrun, framing, parity, or CRC-16) is detected in the command message.
- When the slave address in the command message and the slave address in the drive do not match (remember to set the slave address for the drive using H5-01).
- When the gap between two blocks (8 bit) of a message exceeds 24 bits.
- When the command message data length is invalid.

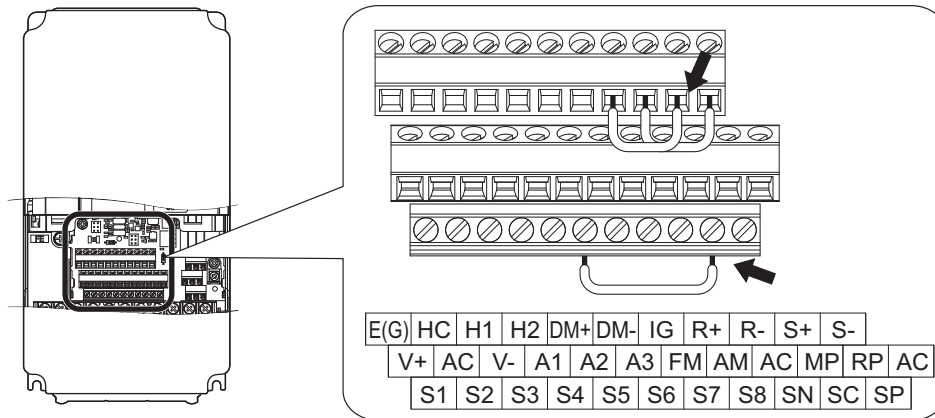
**Note:** If the slave address specified in the command message is 00H, all slaves execute the write function, but do not return response messages to the master.

## C.12 Self-Diagnostics

The drive has a built-in self-diagnosing function of the serial communication interface circuits. To perform the self-diagnosis function, use the following procedure.

**DANGER! Electrical Shock Hazard.** Do not connect or disconnect wiring while the power is on. Failure to comply will result in death or serious injury. Before servicing, disconnect all power to the equipment. The internal capacitor remains charged even after the power supply is turned off. The charge indicator LED will extinguish when the DC bus voltage is below 50 Vdc. To prevent electric shock, wait at least one minute after all indicators are OFF and measure the DC bus voltage level to confirm safe level.

1. Turn on the power to the drive.
2. Note the present terminal S6 function selection setting (H1-06) and set it for the communications test mode (H1-06 = 67).
3. Turn off the power to the drive.



**Figure C.9 Terminal Connections for Communication Self-Diagnostics**

4. With the power off, wire the drive as shown in the following diagram, connecting terminals R+ and S+, R- and S-, and S6 and SC.
5. Set jumper S3 to source mode (internal power supply).
6. Turn the power to the drive back on.
7. During normal operation, the drive will display *PRSS*. This indicates that the communications test mode is operating normally.  
When a fault occurs, the drive will display *EE* on the keypad display.
8. Turn off the power supply.
9. Remove the wire jumpers from terminal R+, R-, S+, S-, and S6-SC. Set back jumper S3 to its original position. Set terminal S6 to its original function.
10. Return to normal operation.

# Appendix: D

## Standards Compliance

---

This appendix explains the guidelines and criteria for maintaining CE and UL standards.

<b>D.1 SECTION SAFETY</b> .....	<b>438</b>
<b>D.2 EUROPEAN STANDARDS</b> .....	<b>440</b>
<b>D.3 UL STANDARDS</b> .....	<b>446</b>
<b>D.4 PRECAUTIONS FOR KOREAN RADIO WAVES ACT</b> .....	<b>458</b>
<b>D.5 한국 전파법에 관한 주의사항</b> .....	<b>459</b>

## D.1 Section Safety

### DANGER

#### Electrical Shock Hazard

**Do not connect or disconnect wiring while the power is on.**

Failure to comply will result in death or serious injury.

### WARNING

#### Electrical Shock Hazard

**Do not operate equipment with covers removed.**

Failure to comply could result in death or serious injury.

The diagrams in this section may show drives without covers or safety shields to show details. Be sure to reinstall covers or shields before operating the drives and run the drives according to the instructions described in this manual.

**Always ground the motor-side grounding terminal.**

Improper equipment grounding could result in death or serious injury by contacting the motor case.

**Do not touch any terminals before the capacitors have fully discharged.**

Failure to comply could result in death or serious injury.

Before wiring terminals, disconnect all power to the equipment. The internal capacitor remains charged even after the power supply is turned off. After shutting off the power, wait for at least the amount of time specified on the drive before touching any components.

**Do not allow unqualified personnel to perform work on the drive.**

Failure to comply could result in death or serious injury.

Installation, maintenance, inspection, and servicing must be performed only by authorized personnel familiar with installation, adjustment and maintenance of AC drives.

**Do not perform work on the drive while wearing loose clothing, jewelry or without eye protection.**

Failure to comply could result in death or serious injury.

Remove all metal objects such as watches and rings, secure loose clothing, and wear eye protection before beginning work on the drive.

**Do not remove covers or touch circuit boards while the power is on.**

Failure to comply could result in death or serious injury.

**⚠ WARNING****Fire Hazard**

**Tighten all terminal screws to the specified tightening torque.**

Loose electrical connections could result in death or serious injury by fire due to overheating of electrical connections.

**Do not use an improper voltage source.**

Failure to comply could result in death or serious injury by fire.

Verify that the rated voltage of the drive matches the voltage of the incoming power supply before applying power.

**Do not use improper combustible materials.**

Failure to comply could result in death or serious injury by fire.

Attach the drive to metal or other noncombustible material.

**NOTICE**

**Observe proper electrostatic discharge procedures (ESD) when handling the drive and circuit boards.**

Failure to comply may result in ESD damage to the drive circuitry.

**Never connect or disconnect the motor from the drive while the drive is outputting voltage.**

Improper equipment sequencing could result in damage to the drive.

**Do not use unshielded wire for control wiring.**

Failure to comply may cause electrical interference resulting in poor system performance. Use shielded twisted-pair wires and ground the shield to the ground terminal of the drive.

**Do not allow unqualified personnel to use the product.**

Failure to comply could result in damage to the drive or braking circuit.

Carefully review instruction manual TOBPC72060000 when connecting a braking option to the drive.

**Do not modify the drive circuitry.**

Failure to comply could result in damage to the drive and will void warranty.

Yaskawa is not responsible for modification of the product made by the user. This product must not be modified.

**Check all the wiring to ensure that all connections are correct after installing the drive and connecting other devices.**

Failure to comply could result in damage to the drive.

## D.2 European Standards



Figure D.1 CE Mark

The CE mark indicates compliance with European safety and environmental regulations. It is required for engaging in business and commerce in Europe.

European standards include the Machinery Directive for machine manufacturers, the Low Voltage Directive for electronics manufacturers, and the EMC guidelines for controlling noise.

This drive displays the CE mark based on the EMC guidelines and the Low Voltage Directive.

- **Low Voltage Directive:** 2006/95/EC
- **EMC Guidelines:** 2004/108/EC

Devices used in combination with this drive must also be CE certified and display the CE mark. When using drives displaying the CE mark in combination with other devices, it is ultimately the responsibility of the user to ensure compliance with CE standards. After setting up the device, verify that conditions meet European standards.

### ◆ CE Low Voltage Directive Compliance

This drive has been tested according to European standard IEC61800-5-1, and it fully complies with the Low Voltage Directive.

To comply with the Low Voltage Directive, be sure to meet the following conditions when combining this drive with other devices:

#### ■ Area of Use

Do not use drives in areas with pollution higher than severity 2 and overvoltage category 3 in accordance with IEC664.

#### ■ Installing Fuses on the Input Side

Always install input fuses. Select fuses according to [Table D.1](#).

Table D.1 Recommended Input Fuse Selection

Model CIMR-E□	Fuse Type (Rated Voltage: 500 Vac)	
	Manufacturer: Bussmann	
	Model	Fuse Ampere Rating (A)
Three-Phase 200 V Class		
2A0004	FWH-70B	70
2A0006	FWH-70B	70
2A0008	FWH-70B	70
2A0010	FWH-70B	70
2A0012	FWH-70B	70
2A0018	FWH-90B	90
2A0021	FWH-90B	90
2A0030	FWH-100B	100
2A0040	FWH-200B	200
2A0056	FWH-200B	200
2A0069	FWH-200B	200
2A0081	FWH-300A	300
2A0110	FWH-300A	300
2A0138	FWH-350A	350
2A0169	FWH-400A	400
2A0211	FWH-400A	400
2A0250	FWH-600A	600
2A0312	FWH-700A	700
2A0360	FWH-800A	800
2A0415	FWH-1000A	1000



Model CIMR-E□	Fuse Type (Rated Voltage: 500 Vac)	
	Manufacturer: Bussmann	
	Model	Fuse Ampere Rating (A)
Three-Phase 400 V Class		
4A0002	FWH-40B	40
4A0004	FWH-50B	50
4A0005	FWH-70B	70
4A0007	FWH-70B	70
4A0009	FWH-90B	90
4A0011	FWH-90B	90
4A0018	FWH-80B	80
4A0023	FWH-100B	100
4A0031	FWH-125B	125
4A0038	FWH-200B	200
4A0044	FWH-250A	250
4A0058	FWH-250A	250
4A0072	FWH-250A	250
4A0088	FWH-250A	250
4A0103	FWH-250A	250
4A0139	FWH-350A	350
4A0165	FWH-400A	400
4A0208	FWH-500A	500
4A0250	FWH-600A	600
4A0296	FWH-700A	700
4A0362	FWH-800A	800
4A0414	FWH-800A	800
4A0515	FWH-1000A	1000
4A0675	FWH-1200A	1200
4A0930	FWH-1200A	1200
4A1200	FWH-1600A	1600

### ■ Guarding Against Harmful Materials

When installing IP00 enclosure drives, use an enclosure that prevents foreign material from entering the drive from above or below.

### ■ Grounding

The drive is designed to be used in T-N (grounded neutral point) networks. If installing the drive in other types of grounded systems, contact your Yaskawa representative for instructions.

## ◆ EMC Guidelines Compliance

This drive is tested according to European standards EN61800-3: 2004, and complies with the EMC guidelines.

### ■ EMC Filter Installation

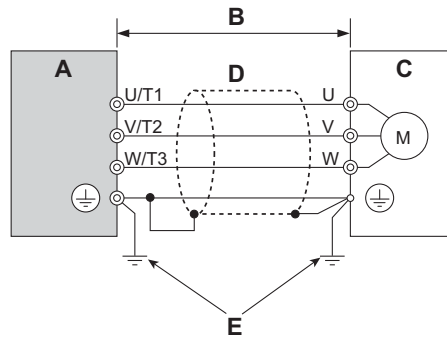
The following conditions must be met to ensure continued compliance with guidelines. [Refer to EMC Filters on page 444](#) for EMC filter selection.

#### Installation Method

Verify the following installation conditions to ensure that other devices and machinery used in combination with this drive also comply with EMC guidelines.

1. Install an EMC noise filter to the input side specified by Yaskawa for compliance with European standards.
2. Place the drive and EMC noise filter in the same enclosure.
3. Use braided shield cable for the drive and motor wiring, or run the wiring through a metal conduit.
4. Keep wiring as short as possible. Ground the shield on both the drive side and the motor side.

## D.2 European Standards



A – Drive

B – 10 m max cable length between drive and motor

C – Motor

D – Metal conduit

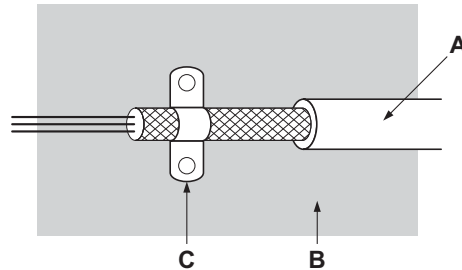
E – Ground wire should be as short as possible.

Figure D.2 Installation Method

5. Make sure the protective earthing conductor complies with technical standards and local safety regulations.

**WARNING! Electrical Shock Hazard.**

Because the leakage current exceeds 3.5 mA in models CIMR-E□4A0414 to 4A1200, IEC 61800-5-1 states that either the power supply must be automatically disconnected in case of discontinuity of the protective earthing conductor or a protective earthing conductor with a cross-section of at least 10 mm<sup>2</sup> (Cu) or 16 mm<sup>2</sup> (Al) must be used. Failure to comply may result in death or serious injury.



A – Braided shield cable

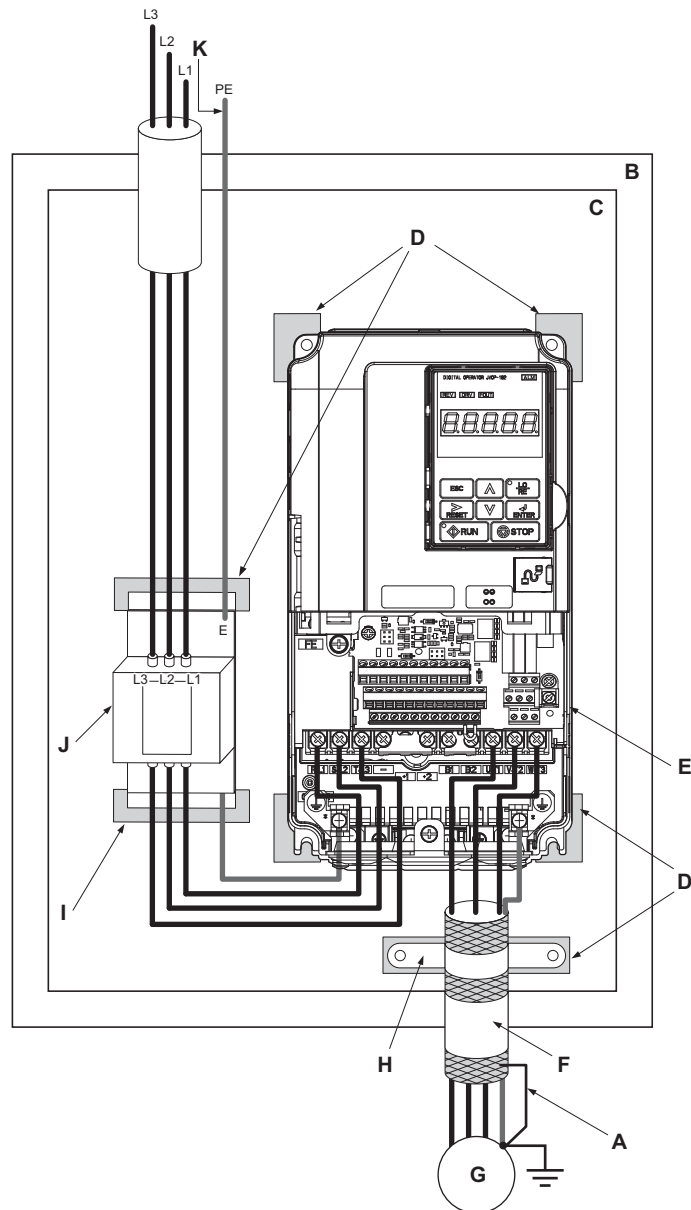
B – Metal panel

C – Cable clamp (conductive)

Figure D.3 Ground Area

6. Connect a DC reactor to minimize harmonic distortion. See page [445](#).

Three-Phase 200 V / 400 V Class



- A – Ground the cable shield
- B – Enclosure panel
- C – Metal plate
- D – Grounding surface (remove any paint or sealant)
- E – Drive
- F – Motor cable (braided shield cable, max. 10 m)
- G – Motor
- H – Cable clamp
- I – Ground plate (scrape off any visible paint)
- J – EMC noise filter
- K – Make sure the ground wire is grounded

Figure D.4 EMC Filter and Drive Installation for CE Compliance (Three-Phase 200 V / 400 V Class)

## D.2 European Standards

### ■ EMC Filters

The drive should be installed with the EMC filters listed below in order to comply with the EN61800-3, category C2 requirements.

**Table D.2 EN61800-3 C2 Filters**

Model CIMR-E□	Filter Data (Manufacturer: Schaffner)					
	Type	Rated Current (A)	Weight (kg)	Dimensions [W × D × H] (mm)	Y × X	Figure
<b>Three-Phase 200 V Class</b>						
2A0004	FS5972-10-07	10	1.2	141 × 46 × 330	115 × 313	1
2A0006						
2A0008						
2A0010	FS5972-18-07	18	1.3	141 × 46 × 330	115 × 313	
2A0012						
2A0018						
2A0021	FS5972-35-07	35	2.1	206 × 50 × 355	175 × 336	
2A0030						
2A0040	FS5972-60-07	60	4.0	236 × 65 × 408	205 × 390	
2A0056						
2A0069	FS5972-100-35	100	3.4	90 × 150 × 330	65 × 255	
2A0081						
2A0110	FS5972-170-40	170	6.0	120 × 170 × 451	102 × 365	2
2A0138						
2A0169	FS5972-250-37	250	11.7	130 × 240 × 610	90 × 498	
2A0211						
2A0250	FS5972-410-99	410	10.5	260 × 115 × 386	235 × 120	
2A0312						
2A0360	FS5972-600-99	600	11	260 × 135 × 386	235 × 120	1
2A0415						
<b>Three-Phase 400 V Class</b>						
4A0002	FS5972-10-07	10	1.1	141 × 46 × 330	115 × 313	1
4A0004						
4A0005						
4A0007	FS5972-18-07	18	1.7	141 × 46 × 330	115 × 313	
4A0009						
4A0011						
4A0018	FS5972-35-07	35	2.1	206 × 50 × 355	175 × 336	
4A0023						
4A0031	FS5972-60-07	60	4	236 × 65 × 408	205 × 390	
4A0038						
4A0044						
4A0058	FS5972-100-35	100	3.4	90 × 150 × 330	65 × 255	
4A0072						
4A0088	FS5972-170-40	170	4.7	120 × 170 × 451	102 × 365	2
4A0103						
4A0139						
4A0165	FS5972-250-37	250	11.7	130 × 240 × 610	90 × 498	
4A0208						
4A0250	FS5972-410-99	400	10.5	260 × 115 × 386	235 × 120	
4A0296						
4A0362						
4A0414	FS5972-600-99	600	11	260 × 135 × 386	235 × 120	3
4A0515						
4A0675	FS5972-800-99	800	31.5	300 × 160 × 716	275 × 210	
4A0930	FS5972-600-99 <I>	600	11	260 × 135 × 386	235 × 120	
4A1200	FS5972-800-99 <I>	800	31.5	300 × 160 × 716	275 × 210	

<I> Connect two of the same EMC filters in parallel.

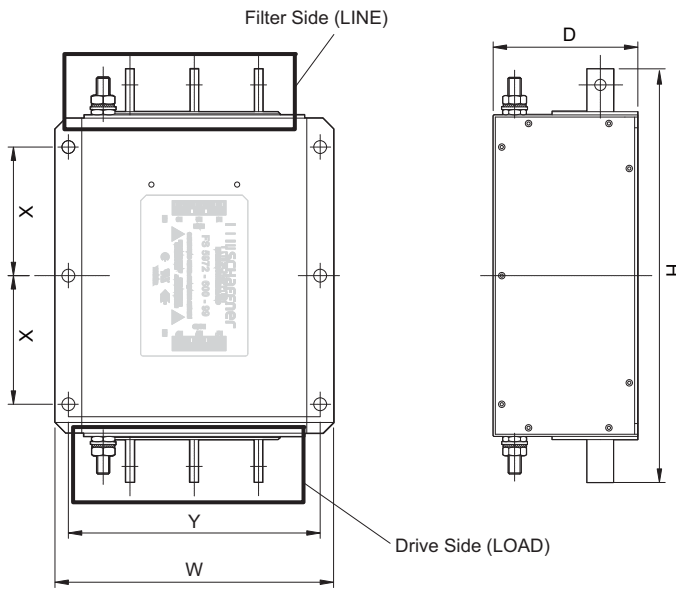
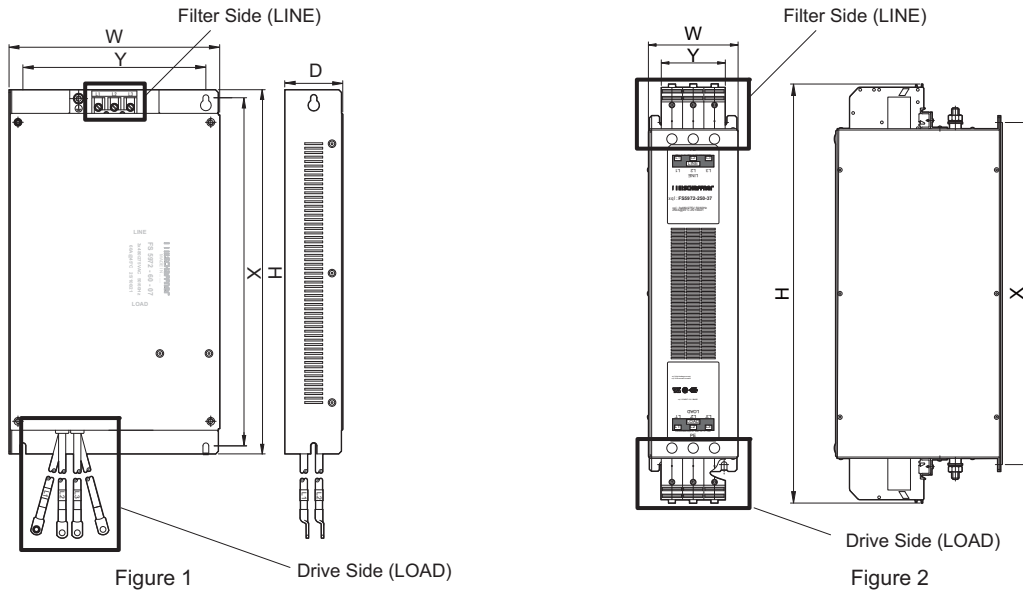


Figure 3

Figure D.5 EMC Filter Dimensions

■ DC Reactors for EN 61000-3-2 Compliance

Table D.3 DC Reactors for Harmonics Reduction

Drive Model CIMR-E□	DC Reactor	
	Model	Rating
200V Three-Phase Units		
2A0004	UZDA-B	5.4 A 8 mH
2A0006		
400 V Three-Phase Units		
4A0002	UZDA-B	3.2 A 28 mH
4A0004		

**Note:** Contact Yaskawa for information about DC reactors for other models.

## D.3 UL Standards

### ◆ UL Standards Compliance

The UL/cUL mark applies to products in the United States and Canada. It indicates that UL has performed product testing and evaluation, and determined that their stringent standards for product safety have been met. For a product to receive UL certification, all components inside that product must also receive UL certification.



Figure D.6 UL/cUL Mark

This drive is tested in accordance with UL standard UL508C and complies with UL requirements. The conditions described below must be met to maintain compliance when using this drive in combination with other equipment:

**Note:** Model CIMR-E□4A0930 and 4A1200 is UL compliant when the air entering the drive-installed panel or cabinet is 45°C or less. For more information, contact your nearest Yaskawa representative or our sales office.

### ■ Installation Area

Do not install the drive to an area greater than pollution severity degree 2 (UL standard).

### ■ Ambient Temperature

Install the drive in an environment with an ambient temperature of -10 °C to 40 °C (NEMA Type 1 enclosure), -10 °C to 50 °C (IP00 enclosure), and up to 60 °C with a derated output current for the drive.

### ■ Main Circuit Terminal Wiring

Yaskawa recommends using closed-loop crimp terminals on all drive models. UL/cUL approval requires the use of closed-loop crimp terminals when wiring the drive main circuit terminals on models CIMR-E□2A0110 to 2A0415 and 4A0058 to 4A1200. Use only the tools recommended by the terminal manufacturer for crimping.

The wire gauges listed in [Table D.4](#) and [Table D.5](#) are Yaskawa recommendations. Refer to local codes for proper wire gauge selections.

**Note:** The mark ⊕ indicates the terminals for protective ground connection. (as defined in IEC60417-5019)  
 Grounding impedance;  
 200 V: 100 Ω or less  
 400 V: 10 Ω or less

Table D.4 Wire Gauge and Torque Specifications (Three-phase 200 V Class)

Model CIMR-E□	Terminal	For Europe and China <1>		For U.S.A. <2>		For Asia <3>		Screw Size	Tightening Torque N·m (lb.in.)
		Recommended Gauge mm <sup>2</sup>	Applicable Gauge mm <sup>2</sup>	Recommended Gauge AWG, kcmil	Applicable Gauge AWG, kcmil	Recommended Gauge mm <sup>2</sup>	Applicable Gauge mm <sup>2</sup>		
2A0004 2A0006 2A0008 2A0010	R/L1, S/L2, T/L3	2.5	2.5 to 6	14	14 to 10	2	2 to 5.5	M4	1.2 to 1.5 (10.6 to 13.3)
	U/T1, V/T2, W/T3	2.5	2.5 to 6	14	14 to 10	2	2 to 5.5		
	-, +1, +2	-	2.5 to 6	-	14 to 10	2	2 to 5.5		
	⊕	2.5	2.5 to 6	10	14 to 10	2	2 to 5.5		
2A0012	R/L1, S/L2, T/L3	2.5	2.5 to 6	12	14 to 10	2	2 to 5.5	M4	1.2 to 1.5 (10.6 to 13.3)
	U/T1, V/T2, W/T3	2.5	2.5 to 6	14	14 to 10	2	2 to 5.5		
	-, +1, +2	-	2.5 to 6	-	14 to 10	2	2 to 5.5		
	⊕	2.5	2.5 to 6	10	14 to 10	3.5	2 to 5.5		
2A0021	R/L1, S/L2, T/L3	4	2.5 to 6	10	12 to 10	5.5	3.5 to 5.5	M4	1.2 to 1.5 (10.6 to 13.3)
	U/T1, V/T2, W/T3	2.5	2.5 to 6	10	12 to 10	3.5	3.5 to 5.5		
	-, +1, +2	-	4 to 6	-	12 to 10	5.5	3.5 to 5.5		
	⊕	4	4 to 6	10	12 to 10	3.5	3.5 to 5.5		
2A0030	R/L1, S/L2, T/L3	6	4 to 16	8	10 to 6	14	5.5 to 14	M4	2.1 to 2.3 (18.4 to 20.4)
	U/T1, V/T2, W/T3	6	4 to 16	8	10 to 6	8	5.5 to 14		
	-, +1, +2	-	6 to 16	-	10 to 6	14	5.5 to 14		
	⊕	6	6 to 10	8	10 to 8	5.5	5.5 to 8		

Model CIMR-E□	Terminal	For Europe and China <1>		For U.S.A. <2>		For Asia <3>		Screw Size	Tightening Torque N·m (lb.in.)		
		Recommended Gauge mm <sup>2</sup>	Applicable Gauge mm <sup>2</sup>	Recommended Gauge AWG, kcmil	Applicable Gauge AWG, kcmil	Recommended Gauge mm <sup>2</sup>	Applicable Gauge mm <sup>2</sup>				
2A0040	R/L1, S/L2, T/L3	10	6 to 16	6	8 to 6	14	14	M4	2.1 to 2.3 (18.4 to 20.4)		
	U/T1, V/T2, W/T3	10	6 to 16	8	8 to 6	14	8 to 14				
	-, +1, +2	-	16	-	6	14	14				
	⊕	10	6 to 10	8	10 to 8	5.5	5.5 to 8	M5	2 to 2.5 (17.7 to 22.1)		
2A0056	R/L1, S/L2, T/L3	16	16 to 25	4	6 to 4	22	14 to 22	M6	5.4 to 6.0 (47.8 to 53.1)		
	U/T1, V/T2, W/T3	16	16 to 25	4	6 to 4	14	14 to 22				
	-, +1, +2	-	16 to 25	-	6 to 4	22	14 to 22				
	⊕	16	10 to 16	6	8 to 6	8	8 to 14	M6	4 to 6 (35.4 to 53.1)		
2A0069	R/L1, S/L2, T/L3	25	16 to 25	3	4 to 3	30	22 to 30	M8	9.9 to 11.0 (87.6 to 97.4)		
	U/T1, V/T2, W/T3	16	16 to 25	3	4 to 3	22	14 to 30				
	-, +1, +2	-	25	-	4 to 3	30	22 to 30				
	⊕	16	16 to 25	6	6 to 4	8	8 to 22	M6	4 to 6 (35.4 to 53.1)		
2A0081	R/L1, S/L2, T/L3	35	25 to 35	2	3 to 2	38	30 to 38	M8	9.9 to 11.0 (87.6 to 97.4)		
	U/T1, V/T2, W/T3	25	25 to 35	2	3 to 2	30	22 to 38				
	-, +1, +2	-	25 to 35	-	3 to 2	38	30 to 38				
	⊕	16	16 to 25	6	6 to 4	14	14 to 22	M6	4 to 6 (35.4 to 53.1)		
2A0110 <2>	R/L1, S/L2, T/L3	35	25 to 50	1/0	3 to 1/0	38	30 to 50	M8	9 to 11 (79.7 to 97.4)		
	U/T1, V/T2, W/T3	35	25 to 50	1/0	3 to 1/0	38	30 to 50				
	-, +1	-	35 to 50	-	2 to 1/0	60	38 to 60				
	⊕	16	16 to 25	6	6 to 4	14	14 to 38				
2A0138 <2>	R/L1, S/L2, T/L3	50	35 to 70	2/0	1 to 2/0	60	50 to 60	M10	18 to 23 (159 to 204)		
	U/T1, V/T2, W/T3	50	35 to 70	2/0	1 to 2/0	60	50 to 60				
	-, +1	-	50 to 70	-	1/0 to 3/0	80	60 to 80				
	⊕	25	25	4	4	22	22 to 38	M8	9 to 11 (79.7 to 97.4)		
2A0169 <2>	R/L1, S/L2, T/L3	70	50 to 95	4/0	2/0 to 4/0	80	60 to 100	M10	18 to 23 (159 to 204)		
	U/T1, V/T2, W/T3	70	50 to 95	4/0	3/0 to 4/0	80	60 to 100				
	-, +1	-	35 to 95	-	1 to 4/0	50 × 2P	50 to 100				
	+3	-	50 to 95	-	1/0 to 4/0	60	50 to 100				
	⊕	35	25 to 35	4	4 to 2	22	22 to 60				
2A0211 <2>	R/L1, S/L2, T/L3	95	70 to 95	1/0 × 2P	1/0 to 2/0	100	80 to 100	M10	18 to 23 (159 to 204)		
	U/T1, V/T2, W/T3	95	70 to 95	1/0 × 2P	1/0 to 2/0	50 × 2P	50 to 60				
	-, +1	-	35 to 95	-	1 to 4/0	50 × 2P	50 to 100				
	+3	-	50 to 95	-	1/0 to 4/0	80	60 to 100				
	⊕	50	25 to 50	4	4 to 1/0	22	22 to 60				
2A0250 <2>	R/L1, S/L2, T/L3	95 × 2P	95 to 150	3/0 × 2P	3/0 to 300	80 × 2P	38 to 150	M12	32 to 40 (283 to 354)		
	U/T1, V/T2, W/T3	95 × 2P	95 to 150	3/0 × 2P	3/0 to 300	80 × 2P	38 to 150				
	-, +1	-	70 to 150	-	3/0 to 300	80 × 2P	80 to 150				
	+3	-	35 to 150	-	2 to 300	80 × 2P	30 to 150	M10	18 to 23 (159 to 204)		
	⊕	95	95 to 150	3	3 to 300	22	22 to 150	M12	32 to 40 (283 to 354)		
2A0312 <2>	R/L1, S/L2, T/L3	95 × 2P	95 to 150	4/0 × 2P	3/0 to 300	80 × 2P	70 to 150	M12	32 to 40 (283 to 354)		
	U/T1, V/T2, W/T3	95 × 2P	95 to 150	3/0 × 2P	3/0 to 300	80 × 2P	70 to 200				
	-, +1	-	70 to 150	-	3/0 to 300	150 × 2P	80 to 150				
	+3	-	70 to 150	-	3/0 to 300	80 × 2P	80 to 150	M10	18 to 23 (159 to 204)		
	⊕	95	95 to 150	2	2 to 300	38	38 to 150	M12	32 to 40 (283 to 354)		
2A0360 <2>	R/L1, S/L2, T/L3	240	95 to 300	250 × 2P	4/0 to 600	100 × 2P	80 to 325	M12	32 to 40 (283 to 354)		
	U/T1, V/T2, W/T3	240	95 to 300	4/0 × 2P	4/0 to 600	100 × 2P	80 to 325				
	-, +1	-	125 to 300	-	250 to 600	150 × 2P	125 to 325				
	+3	-	70 to 300	-	3/0 to 600	80 × 2P	80 to 325			M10	18 to 23 (159 to 204)
	⊕	120	120 to 240	1	1 to 350	38	38 to 200			M12	32 to 40 (283 to 354)

## D.3 UL Standards

Model CIMR-E□	Terminal	For Europe and China <1>		For U.S.A. <2>		For Asia <3>		Screw Size	Tightening Torque N·m (lb.in.)
		Recommended Gauge mm <sup>2</sup>	Applicable Gauge mm <sup>2</sup>	Recommended Gauge AWG, kcmil	Applicable Gauge AWG, kcmil	Recommended Gauge mm <sup>2</sup>	Applicable Gauge mm <sup>2</sup>		
2A0415 <4>	R/L1, S/L2, T/L3	120 × 2P	95 to 300	350 × 2P	250 to 600	125 × 2P	100 to 325	M12	32 to 40 (283 to 354)
	U/T1, V/T2, W/T3	300	95 to 300	300 × 2P	300 to 600	125 × 2P	125 to 325		
	-, +1	-	150 to 300	-	300 to 600	200 × 2P	150 to 325		
	+3	-	70 to 300	-	3/0 to 600	100 × 2P	80 to 325	M10	18 to 23 (159 to 204)
	⊕	120	120 to 240	1	1 to 350	60	60 to 200	M12	32 to 40 (283 to 354)

<1> Gauges listed here are for use in Europe and China.

<2> Gauges listed here are for use in the United States.

<3> Gauges listed here are for use in Asia except for China.

<4> Drive models CIMR-E□2A0110 to 2A0415 require the use of closed-loop crimp terminals for UL/cUL compliance. Use only the tools recommended by the terminal manufacturer for crimping.

**Note:** Use crimp insulated terminals or insulated tubing for wiring these connections. Wires should have a continuous maximum allowable temperature of 75°C 600 V UL approved vinyl sheathed insulation. Ambient temperature should not exceed 40°C.

**Table D.5 Wire Gauge and Torque Specifications (Three-Phase 400 V Class)**

Model CIMR-E□	Terminal	For Europe and China <1>		For U.S.A. <2>		For Asia <3>		Screw Size	Tightening Torque N·m (lb.in.)
		Recommended Gauge mm <sup>2</sup>	Applicable Gauge mm <sup>2</sup>	Recommended Gauge AWG, kcmil	Applicable Gauge AWG, kcmil	Recommended Gauge mm <sup>2</sup>	Applicable Gauge mm <sup>2</sup>		
4A0002 4A0004	R/L1, S/L2, T/L3	2.5	2.5 to 6	14	14 to 10	2	2 to 5.5	M4	1.2 to 1.5 (10.6 to 13.3)
	U/T1, V/T2, W/T3	2.5	2.5 to 6	14	14 to 10	2	2 to 5.5		
	-, +1, +2	-	2.5 to 6	-	14 to 10	2	2 to 5.5		
	⊕	2.5	2.5 to 4	12	14 to 12	2	2 to 5.5		
4A0005 4A0007 4A0009	R/L1, S/L2, T/L3	2.5	2.5 to 6	14	14 to 10	2	2 to 5.5	M4	1.2 to 1.5 (10.6 to 13.3)
	U/T1, V/T2, W/T3	2.5	2.5 to 6	14	14 to 10	2	2 to 5.5		
	-, +1, +2	-	2.5 to 6	-	14 to 10	2	2 to 5.5		
	⊕	2.5	2.5 to 6	10	14 to 10	3.5	2 to 5.5		
4A0011	R/L1, S/L2, T/L3	2.5	2.5 to 6	12	14 to 10	2	2 to 5.5	M4	1.2 to 1.5 (10.6 to 13.3)
	U/T1, V/T2, W/T3	2.5	2.5 to 6	14	14 to 10	2	2 to 5.5		
	-, +1, +2	-	2.5 to 6	-	14 to 10	2	2 to 5.5		
	⊕	2.5	2.5 to 6	10	14 to 10	3.5	2 to 5.5		
4A0018	R/L1, S/L2, T/L3	2.5	2.5 to 16	10	12 to 6	3.5	2 to 14	M4	2.1 to 2.3 (18.4 to 20.4)
	U/T1, V/T2, W/T3	2.5	2.5 to 16	10	12 to 6	3.5	2 to 14		
	-, +1, +2	-	4 to 16	-	12 to 6	3.5	2 to 14		
	⊕	2.5	2.5 to 6	10	14 to 10	3.5	2 to 5.5	M5	2 to 2.5 (17.7 to 22.1)
4A0023	R/L1, S/L2, T/L3	4	2.5 to 16	10	10 to 6	5.5	3.5 to 14	M4	2.1 to 2.3 (18.4 to 20.4)
	U/T1, V/T2, W/T3	4	2.5 to 16	10	10 to 6	5.5	3.5 to 14		
	-, +1, +2	-	4 to 16	-	12 to 6	5.5	3.5 to 14		
	⊕	4	4 to 6	10	12 to 10	3.5	3.5 to 5.5	M5	2 to 2.5 (17.7 to 22.1)
4A0031	R/L1, S/L2, T/L3	6	6 to 16	8	8 to 6	14	5.5 to 14	M5	2.7 to 3.0 (23.9 to 26.6)
	U/T1, V/T2, W/T3	6	6 to 16	8	10 to 6	8	5.5 to 8		
	-, +1, +2	-	6 to 16	-	10 to 6	14	5.5 to 14		
	⊕	6	6 to 10	8	10 to 8	5.5	5.5 to 8	M6	4 to 6 (35.4 to 53.1)
4A0038	R/L1, S/L2, T/L3	10	10 to 16	6	8 to 6	14	14	M5	2.7 to 3.0 (23.9 to 26.6)
	U/T1, V/T2, W/T3	6	6 to 16	8	8 to 6	14	8 to 14		
	-, +1, +2	-	6 to 16	-	6	14	14		
	⊕	10	6 to 16	6	10 to 6	8	5.5 to 14	M6	4 to 6 (35.4 to 53.1)
4A0044	R/L1, S/L2, T/L3	16	16 to 25	6	6 to 4	14	14 to 22	M6	5.4 to 6.0 (47.8 to 53.1)
	U/T1, V/T2, W/T3	16	16 to 25	6	6 to 4	14	14 to 22		
	-, +1, +2	-	16 to 25	-	6 to 4	14	14 to 22		
	⊕	16	10 to 16	6	8 to 6	8	8 to 14	M6	4 to 6 (35.4 to 53.1)
4A0058 <4>	R/L1, S/L2, T/L3	16	10 to 16	4	6 to 4	14	14	M8	9 to 11 (79.7 to 97.4)
	U/T1, V/T2, W/T3	16	10 to 16	4	6 to 4	14	14		
	-, +1	-	16 to 35	-	6 to 1	22	14 to 38		
	⊕	16	10 to 16	6	8 to 6	8	8 to 14		



Model CIMR-E□	Terminal	For Europe and China <←>		For U.S.A. <↔>		For Asia <↔>		Screw Size	Tightening Torque N·m (lb.in.)
		Recommended Gauge mm <sup>2</sup>	Applicable Gauge mm <sup>2</sup>	Recommended Gauge AWG, kcmil	Applicable Gauge AWG, kcmil	Recommended Gauge mm <sup>2</sup>	Applicable Gauge mm <sup>2</sup>		
4A0072 <↔>	R/L1, S/L2, T/L3	16	16 to 25	3	4 to 3	22	14 to 22	M8	9 to 11 (79.7 to 97.4)
	U/T1, V/T2, W/T3	25	16 to 25	3	4 to 3	22	14 to 22		
	-, +1	-	25 to 35	-	4 to 1	30	22 to 38		
	⊕	16	16 to 25	6	6	14	14 to 22		
4A0088 <↔>	R/L1, S/L2, T/L3	25	16 to 50	2	3 to 1/0	30	22 to 60	M8	9 to 11 (79.7 to 97.4)
	U/T1, V/T2, W/T3	25	25 to 50	2	3 to 1/0	30	22 to 60		
	-, +1	-	25 to 50	-	3 to 1/0	38	30 to 60		
	+3	-	16 to 50	-	6 to 1/0	22	14 to 60		
	⊕	16	16 to 25	4	6 to 4	22	14 to 22		
4A0103 <↔>	R/L1, S/L2, T/L3	35	25 to 50	1/0	2 to 1/0	38	30 to 60	M8	9 to 11 (79.7 to 97.4)
	U/T1, V/T2, W/T3	35	25 to 50	1	2 to 1/0	38	30 to 60		
	-, +1	-	25 to 50	-	3 to 1/0	60	30 to 60		
	+3	-	25 to 50	-	4 to 1/0	30	22 to 60		
	⊕	16	16 to 25	4	6 to 4	22	14 to 22		
4A0139 <↔>	R/L1, S/L2, T/L3	50	35 to 95	3/0	1/0 to 4/0	60	38 to 100	M10	18 to 23 (159 to 204)
	U/T1, V/T2, W/T3	50	35 to 95	2/0	1/0 to 4/0	60	50 to 100		
	-, +1	-	50 to 95	-	1/0 to 4/0	100	60 to 100		
	+3	-	25 to 95	-	3 to 4/0	50	30 to 100		
	⊕	25	25	4	4	22	22		
4A0165 <↔>	R/L1, S/L2, T/L3	70	50 to 95	4/0	3/0 to 4/0	80	60 to 100	M10	18 to 23 (159 to 204)
	U/T1, V/T2, W/T3	70	70 to 95	4/0	3/0 to 4/0	80	80 to 100		
	-, +1	-	35 to 95	-	1 to 4/0	50 × 2P	50 to 100		
	+3	-	50 to 95	-	1/0 to 4/0	60	50 to 100		
	⊕	35	25 to 35	4	4 to 2	22	22 to 30		
4A0208 <↔>	R/L1, S/L2, T/L3	95	35 to 95	300	2 to 300	150	30 to 150	M10	18 to 23 (159 to 204)
	U/T1, V/T2, W/T3	95	35 to 95	300	2 to 300	150	30 to 150		
	-, +1	-	35 to 150	-	1 to 250	80 × 2P	38 to 150		
	+3	-	25 to 70	-	3 to 3/0	80	22 to 80		
	⊕	50	50 to 150	4	4 to 300	22	22 to 150		
4A0250 <↔>	R/L1, S/L2, T/L3	120	95 to 300	400	1 to 600	150	38 to 325	M10	18 to 23 (159 to 204)
	U/T1, V/T2, W/T3	120	95 to 300	400	1/0 to 600	150	38 to 325		
	-, +1	-	70 to 300	-	3/0 to 600	200	80 to 325		
	+3	-	35 to 300	-	1 to 325	125	38 to 325		
	⊕	70	70 to 240	2	2 to 350	22	22 to 200		
4A0296 <↔>	R/L1, S/L2, T/L3	185	95 to 300	500	2/0 to 600	200	80 to 325	M12	32 to 40 (283 to 354)
	U/T1, V/T2, W/T3	185	95 to 300	500	2/0 to 600	200	80 to 325		
	-, +1	-	70 to 300	-	3/0 to 600	325	80 to 325	M10	18 to 23 (159 to 204)
	+3	-	35 to 300	-	1 to 325	150	38 to 325		
	⊕	95	95 to 240	2	2 to 350	30	30 to 200	M12	32 to 40 (283 to 354)
4A0362 <↔>	R/L1, S/L2, T/L3	240	95 to 300	4/0 × 2P	3/0 to 600	250	80 to 325	M12	32 to 40 (283 to 354)
	U/T1, V/T2, W/T3	240	95 to 300	4/0 × 2P	3/0 to 600	250	80 to 325		
	-, +1	-	95 to 300	-	4/0 to 600	325	100 to 325	M10	18 to 23 (159 to 204)
	+3	-	70 to 300	-	3/0 to 600	200	80 to 325		
	⊕	120	120 to 240	1	1 to 350	30	30 to 200	M12	32 to 40 (283 to 354)
4A0414 <↔>	R/L1, S/L2, T/L3	95 × 2P	95 to 150	300 × 2P	4/0 to 300	100 × 2P	80 to 150	M12	32 to 40 (283 to 354)
	U/T1, V/T2, W/T3	95 × 2P	95 to 150	300 × 2P	4/0 to 300	125 × 2P	80 to 150		
	-, +1	-	70 to 150	-	3/0 to 300	150 × 2P	80 to 150		
	+3	-	70 to 150	-	3/0 to 300	80 × 2P	80 to 150		
	⊕	95	35 to 95	1	1 to 3/0	38	38 to 100		

## D.3 UL Standards

Model CIMR-E□	Terminal	For Europe and China <1>		For U.S.A. <2>		For Asia <3>		Screw Size	Tightening Torque N·m (lb.in.)
		Recommended Gauge mm <sup>2</sup>	Applicable Gauge mm <sup>2</sup>	Recommended Gauge AWG, kcmil	Applicable Gauge AWG, kcmil	Recommended Gauge mm <sup>2</sup>	Applicable Gauge mm <sup>2</sup>		
4A0515 <4>	R/L1, S/L2, T/L3	120 × 2P	95 to 150	3/0 × 4P	3/0 to 300	125 × 2P	80 to 150	M12	32 to 40 (283 to 354)
	U/T1, V/T2, W/T3	150 × 2P	95 to 150	4/0 × 4P	3/0 to 300	150 × 2P	80 to 150		
	-, +1	–	70 to 150	–	1/0 to 300	60 × 4P	60 to 150		
	+3	–	70 to 150	–	1/0 to 300	100 × 2P	60 to 150		
	⊕	150	50 to 150	1/0	1/0 to 300	60	50 to 150		
4A0675 <4>	R/L1, S/L2, T/L3	95 × 4P	95 to 150	300 × 4P	4/0 to 300	80 × 4P	80 to 150	M12	32 to 40 (283 to 354)
	U/T1, V/T2, W/T3	95 × 4P	95 to 150	300 × 4P	4/0 to 300	80 × 4P	80 to 150		
	-, +1	–	70 to 150	–	1/0 to 300	125 × 4P	60 to 150		
	+3	–	70 to 150	–	1/0 to 300	60 × 4P	60 to 150		
	⊕	95 × 2P	60 to 150	2/0	2/0 to 300	60	70 to 150		
4A0930 <4>	R/L1, S/L2, T/L3, R1/L11, S1/L21, T1/L31	120 × 4P	95 to 150	(4/0 × 4P) × 2	3/0 to 300	150 × 4P	125 to 150	M12	32 to 40 (283 to 354)
	U/T1, V/T2, W/T3	120 × 4P	95 to 150	(4/0 × 4P) × 2	3/0 to 300	150 × 4P	125 to 150		
	-, +1	–	95 to 150	–	4/0 to 300	(125 × 4P) × 2	100 to 150		
	+3	–	95 to 150	–	4/0 to 300	125 × 4P	100 to 150		
	⊕	120 × 2P	70 to 120	3/0	3/0 to 250	100	80 to 125		
4A1200 <4>	R/L1, S/L2, T/L3, R1/L11, S1/L21, T1/L31	(95 × 4P) × 2	95 to 150	(300 × 4P) × 2	4/0 to 300	(125 × 4P) × 2	100 to 150	M12	32 to 40 (283 to 354)
	U/T1, V/T2, W/T3	(95 × 4P) × 2	95 to 150	(300 × 4P) × 2	4/0 to 300	(125 × 4P) × 2	100 to 150		
	-, +1	–	120 to 150	–	250 to 300	(150 × 4P) × 2	125 to 150		
	+3	–	95 to 150	–	4/0 to 300	(100 × 4P) × 2	100 to 150		
	⊕	95 × 4P	95 to 120	4/0	4/0 to 250	125	100 to 125		

<1> Gauges listed here are for use in Europe and China.

<2> Gauges listed here are for use in the United States.

<3> Gauges listed here are for use in Asia except for China.

<4> Drive models CIMR-E□4A0058 to 4A1200 require the use of closed-loop crimp terminals for UL/cUL compliance. Use only the tools recommended by the terminal manufacturer for crimping.

**Note:** Use crimp insulated terminals or insulated tubing for wiring these connections. Wires should have a continuous maximum allowable temperature of 75°C 600 V UL approved vinyl sheathed insulation. Ambient temperature should not exceed 40°C.

### Closed-Loop Crimp Terminal Recommendations

Yaskawa recommends using closed-loop crimp terminals on all drive models. UL approval requires the use of crimp terminals when wiring the drive main circuit terminals on models CIMR-E□2A0110 to 2A0415 and 4A0058 to 4A1200. Use only crimping tools as specified by the crimp terminal manufacturer. Yaskawa recommends crimp terminals made by JST and Tokyo DIP (or equivalent) for the insulation cap.

**Table D.6** matches the wire gauges and terminal screw sizes with Yaskawa - recommended crimp terminals, tools, and insulation caps. Refer to the appropriate Wire Gauge and Torque Specifications table for the wire gauge and screw size for your drive model. Place orders with a Yaskawa representatives or the Yaskawa sales department.

**Table D.6 Closed-Loop Crimp Terminal Size**

Model CIMR-E□	Wire Gauge (AWG, kcmil)		Screw Size	Crimp Terminal Model Number	Tool		Insulation Cap Model No.	Code <2>
	R/L1, S/L2, T/L3	U/T1, V/T2, W/T3			Machine No.	Die Jaw		
<b>200 V Class</b>								
2A0004 2A0006 2A0008 2A0010	14 <1>		M4	R2-4	YA-4	AD-900	TP-003	100-054-028
	12			R5.5-4			TP-005	100-054-029
	10							
2A0012	14	14 <1>	M4	R2-4	YA-4	AD-900	TP-003	100-054-028
	12 <1>	12		R5.5-4			TP-005	100-054-029
	10							
2A0018	–	14	M4	R2-4	YA-4	AD-900	TP-003	100-054-028
	12			R5.5-4			TP-005	100-054-029
	10 <1>							
2A0021	12		M4	R5.5-4	YA-4	AD-900	TP-005	100-054-029
	10 <1>							

Model CIMR-E□	Wire Gauge (AWG, kcmil)		Screw Size	Crimp Terminal Model Number	Tool		Insulation Cap Model No.	Code <?>	
	R/L1, S/L2, T/L3	U/T1, V/T2, W/T3			Machine No.	Die Jaw			
2A0030	10		M4	R5.5-4	YA-4	AD-900	TP-005	100-054-029	
	8 </?>			8-4		AD-901	TP-008	100-054-031	
	6			14-NK4		AD-902	TP-014	100-054-033	
2A0040	8	8 </?>	M4	8-4	YA-4	AD-901	TP-008	100-054-031	
	6 </?>	6		14-NK4		AD-902	TP-014	100-054-033	
2A0056	6		M6	R14-6	YA-5	AD-952	TP-014	100-051-261	
	4 </?>			R22-6		AD-953	TP-022	100-051-262	
2A0069	4		M8	R22-8	YA-5	AD-953	TP-022	100-051-263	
	3 </?>			R38-8		AD-954	TP-038	100-051-264	
2A0081	3		M8	R38-8	YA-5	AD-954	TP-038	100-051-264	
	2 </?>								
2A0110	3		M8	R38-8	YA-5	AD-954	TP-038	100-051-264	
	2								
	1								
	1/0 </?>			R60-8	YA-5	AD-955	TP-060	100-051-265	
2A0138	1		M10	R38-10	YF-1 YET-300-1	TD-321, TD-311	TP-060	100-061-114	
	1/0			R60-10		TD-323, TD-312	TP-080	100-051-266	
	2/0 </?>			70-10				100-054-036	
2A0169	2/0	-	M10	70-10	YF-1 YET-300-1	TD-323, TD-312	TP-080	100-054-036	
	3/0			80-10		TD-324, TD-312	TP-100	100-051-267	
	4/0 </?>			R100-10				100-051-269	
2A0211	1/0 × 2P </?>		M10	R60-10	YF-1 YET-300-1	TD-321, TD-311	TP-060	100-051-266	
	2/0 × 2P			70-10		TD-323, TD-312	TP-080	100-054-036	
2A0250	3/0 × 2P </?>		M12	80-L12	YF-1 YET-300-1	TD-323, TD-312	TP-080	100-051-558	
	4/0 × 2P			100-L12		TD-324, TD-312	TP-100	100-051-560	
	-	250 × 2P		150-L12		TD-325, TD-313	TP-150	100-051-562	
	250	-		R150-12			TP-150	100-051-273	
	300								
2A0312	3/0 × 2P	3/0 × 2P </?>	M12	80-L12	YF-1 YET-300-1	TD-323, TD-312	TP-080	100-051-558	
	4/0 × 2P </?>	4/0 × 2P		100-L12		TD-324, TD-312	TP-100	100-051-560	
	250 × 2P			150-L12		TD-325, TD-313	TP-150	100-051-562	
	300 × 2P								
2A0360	4/0 × 2P	4/0 × 2P </?>	M12	100-L12	YF-1 YET-300-1	TD-324, TD-312	TP-100	100-051-560	
	250 × 2P </?>	250 × 2P		150-L12		TD-325, TD-313	TP-150	100-051-562	
	300 × 2P			180-L12		TD-327, TD-314	TP-200	100-066-688	
	350 × 2P			200-L12				100-051-564	
	400 × 2P			325-12					
	500 × 2P								
	600	600 × 2P					TD-328, TD-315	TP-325	100-051-277
2A0415	250 × 2P	-	M12	150-L12	YF-1 YET-300-1	TD-325, TD-313	TP-150	100-051-562	
	300 × 2P	300 × 2P </?>		180-L12		TD-327, TD-314	TP-200	100-066-688	
	350 × 2P </?>	350 × 2P		200-L12				100-051-564	
	400 × 2P			325-12					
	500 × 2P								
	600 × 2P								
<b>400 V Class</b>									
4A0002 4A0004 4A0005 4A0007 4A0009	14 </?>		M4	R2-4	YA-4	AD-900	TP-003	100-054-028	
	12			R5.5-4			TP-005	100-054-029	
	10								
4A0011	14	14 </?>	M4	R2-4	YA-4	AD-900	TP-003	100-054-028	
	12 </?>	12		R5.5-4			TP-005	100-054-029	
	10								
4A0018	12		M4	R5.5-4	YA-4	AD-900	TP-005	100-054-029	
	10 </?>			8-4		AD-901	TP-008	100-054-031	
	8			14-NK4		AD-902	TP-014	100-054-033	
	6								

### D.3 UL Standards

Model CIMR-E□	Wire Gauge (AWG, kcmil)		Screw Size	Crimp Terminal Model Number	Tool		Insulation Cap Model No.	Code <2>			
	R/L1, S/L2, T/L3	U/T1, V/T2, W/T3			Machine No.	Die Jaw					
4A0023	10 <I>		M4	R5.5-4	YA-4	AD-900	TP-005	100-054-029			
	8			8-4		AD-901	TP-008	100-054-031			
	6			14-NK4		AD-902	TP-014	100-054-033			
4A0031	–	10	M5	R5.5-5	YA-4	AD-900	TP-005	100-054-030			
	8 <I>			R8-5		AD-901	TP-008	100-054-032			
	6			R14-5		AD-902	TP-014	100-054-034			
4A0038	8	8 <I>	M5	R8-5	YA-4	AD-901	TP-008	100-054-032			
	6 <I>	6		R14-5		AD-902	TP-014	100-054-034			
4A0044	6 <I>		M6	R14-6	YA-5	AD-952	TP-014	100-051-261			
	4			R22-6		AD-953	TP-022	100-051-262			
4A0058	6		M8	R14-8	YA-5	AD-952	TP-014	100-054-035			
	4 <I>			R22-8		AD-953	TP-022	100-051-263			
4A0072	4		M8	R22-8	YA-5	AD-953	TP-022	100-051-263			
	3 <I>			R38-8		AD-954	TP-038	100-051-264			
4A0088	3		M8	R38-8	YA-5	AD-954	TP-038	100-051-264			
	2 <I>										
	1										
	1/0										
4A0103	2		M8	R38-8	YA-5	AD-954	TP-038	100-051-264			
	1	1 <I>									
	1/0 <I>	1/0									
4A0139	1/0		M10	R60-10	YF-1 YET-300-1	TD-321, TD-311	TP-060	100-051-266			
	2/0	2/0 <I>		70-10		TD-323, TD-312	TP-080	100-054-036			
	3/0 <I>	3/0		80-10		TD-324, TD-312	TP-100	100-051-267			
	4/0			R100-10		TD-324, TD-312	TP-100	100-051-269			
4A0165	3/0		M10	80-10	YF-1 YET-300-1	TD-323, TD-312	TP-080	100-051-267			
	4/0 <I>			R100-10		TD-324, TD-312	TP-100	100-051-269			
4A0208	2 × 2P		M10	38-L10	YF-1 YET-150-1	TD-224, TD-212	TP-038	100-051-556			
	1 × 2P					80-L10	TD-227, TD-214	TP-080	100-051-557		
	3/0 × 2P						R100-10	TD-228, TD-214	TP-100	100-051-269	
	4/0							R150-10	TD-229, TD-215	TP-150	100-051-272
	250										
300 <I>											
4A0250	1 × 2P	–	M10	38-L10	YF-1 YET-150-1	TD-224, TD-212	TP-038	100-051-556			
	3/0 × 2P			80-L10		TD-227, TD-214	TP-080	100-051-557			
	4/0 × 2P			100-L10		TD-228, TD-214	TP-100	100-051-559			
	250 × 2P			150-L10		TD-229, TD-215	TP-150	100-051-561			
	300			R150-10		YF-1 YET-300-1	TD-327, TD-314	TP-200	100-051-272		
	350			180-10					100-066-687		
	400 <I>			200-10				100-051-563			
	500			325-10				TD-328, TD-315	TP-325	100-051-565	
600											
4A0296	3/0 × 2P		M12	80-L12	YF-1 YET-300-1	TD-323, TD-312	TP-080	100-051-558			
	4/0 × 2P			100-L12		TD-324, TD-312	TP-100	100-051-560			
	250 × 2P			150-L12		TD-325, TD-313	TP-150	100-051-562			
	300 × 2P					180-L12	TD-327, TD-314	TP-200	100-066-688		
	–	350 × 2P		100-066-689							
	350	–		R200-12					100-051-275		
	400			325-12		TD-328, TD-315	TP-325	100-051-277			
	500 <I>										
600											

Model CIMR-E□	Wire Gauge (AWG, kcmil)		Screw Size	Crimp Terminal Model Number	Tool		Insulation Cap Model No.	Code <2>
	R/L1, S/L2, T/L3	U/T1, V/T2, W/T3			Machine No.	Die Jaw		
4A0362	3/0 × 2P		M12	80-L12	YF-1 YET-300-1	TD-323, TD-312	TP-080	100-051-558
	4/0 × 2P <1>			100-L12		TD-324, TD-312	TP-100	100-051-560
	250 × 2P			150-L12		TD-325, TD-313	TP-150	100-051-562
	300 × 2P			180-L12		TD-327, TD-314	TP-200	100-066-688
	350 × 2P			200-L12				100-051-564
	400 × 2P			325-12		TD-328, TD-315	TP-325	100-051-277
	500							
	600							
4A0414	4/0 × 2P		M12	100-L12	YF-1 YET-300-1	TD-324, TD-312	TP-100	100-051-560
	250 × 2P			150-L12		TD-325, TD-313	TP-150	100-051-562
	300 × 2P <1>							
4A0515	3/0 × 4P <1>	3/0 × 4P	M12	80-L12	YF-1 YET-300-1	TD-323, TD-312	TP-080	100-051-558
	4/0 × 4P	4/0 × 4P <1>		100-L12		TD-324, TD-312	TP-100	100-051-560
	250 × 4P			150-L12		TD-325, TD-313	TP-150	100-051-562
	300 × 2P							
4A0675	4/0 × 4P		M12	100-L12	YF-1 YET-300-1	TD-324, TD-312	TP-100	100-051-560
	250 × 4P			150-L12		TD-325, TD-313	TP-150	100-051-562
	300 × 4P <1>							
4A0930	3/0 × 8P		M12	80-L12	YF-1 YET-300-1	TD-323, TD-312	TP-080	100-051-558
	4/0 × 8P <1>			100-L12		TD-324, TD-312	TP-100	100-051-560
	250 × 8P			150-L12		TD-325, TD-313	TP-150	100-051-562
	300 × 8P							
4A1200	4/0 × 8P		M12	100-L12	YF-1 YET-300-1	TD-324, TD-312	TP-100	100-051-560
	250 × 8P			150-L12		TD-325, TD-313	TP-150	100-051-562
	300 × 8P <1>							

<1> Recommended wire gauge

<2> Codes refer to a set of three crimp terminals and three insulation caps. Prepare input and output wiring using two sets for each connection.

Example 1: Models with 300 kcmil for both input and output require one set for input terminals and one set for output terminals, so the user should order two sets of [100-051-272].

Example 2: Models with 4/0 AWG × 2P for both input and output require two sets for input terminals and two sets for output terminals, so the user should order four sets of [100-051-560].

### Input Fuse Installation

The installation manual specifies that branch circuit protection should be provided by fuses listed in [Table D.7](#).

**Table D.7 Recommended Input Fuse Selection**

Model CIMR-E□	Fuse Type (Rated Voltage: 500 Vac)	
	Manufacturer: Bussmann	
	Model	Fuse Ampere Rating (A)
Three-Phase 200 V Class		
2A0004	FWH-70B	70
2A0006	FWH-70B	70
2A0008	FWH-70B	70
2A0010	FWH-70B	70
2A0012	FWH-70B	70
2A0018	FWH-90B	90
2A0021	FWH-90B	90
2A0030	FWH-100B	100
2A0040	FWH-200B	200
2A0056	FWH-200B	200
2A0069	FWH-200B	200
2A0081	FWH-300A	300
2A0110	FWH-300A	300
2A0138	FWH-350A	350

## D.3 UL Standards

Model CIMR-E□	Fuse Type (Rated Voltage: 500 Vac)	
	Manufacturer: Bussmann	
	Model	Fuse Ampere Rating (A)
2A0169	FWH-400A	400
2A0211	FWH-400A	400
2A0250	FWH-600A	600
2A0312	FWH-700A	700
2A0360	FWH-800A	800
2A0415	FWH-1000A	1000
Three-Phase 400 V Class		
4A0002	FWH-40B	40
4A0004	FWH-50B	50
4A0005	FWH-70B	70
4A0007	FWH-70B	70
4A0009	FWH-90B	90
4A0011	FWH-90B	90
4A0018	FWH-80B	80
4A0023	FWH-100B	100
4A0031	FWH-125B	125
4A0038	FWH-200B	200
4A0044	FWH-250A	250
4A0058	FWH-250A	250
4A0072	FWH-250A	250
4A0088	FWH-250A	250
4A0103	FWH-250A	250
4A0139	FWH-350A	350
4A0165	FWH-400A	400
4A0208	FWH-500A	500
4A0250	FWH-600A	600
4A0296	FWH-700A	700
4A0362	FWH-800A	800
4A0414	FWH-800A	800
4A0515	FWH-1000A	1000
4A0675	FWH-1200A	1200
4A0930	FWH-1200A	1200
4A1200	FWH-1600A	1600

**Note:** Model CIMR-E□4A1200 is UL compliant when the air entering the drive-installed panel or cabinet is 45°C or less. For more information, contact your nearest Yaskawa representative or our sales office.

### ■ Low Voltage Wiring for Control Circuit Terminals

Wire low voltage wires with NEC Class 1 circuit conductors. Refer to national state or local codes for wiring. Use a class 2 power supply for the control circuit terminal when not using the internal control power supply of the drive. Refer to NEC Article 725 Class 1, Class 2, and Class 3 Remote-Control, Signaling, and Power Limited Circuits for requirements concerning class 1 circuit conductors and class 2 power supplies.

**Table D.8 Control Circuit Terminal Power Supply**

Input / Output	Terminal Signal	Power Supply Specifications
Multi-function digital outputs	M1, M2, M3, M4, M5, M6	Requires class 2 power supply.
Multi-function digital inputs	S1, S2, S3, S4, S5, S6, S7, S8, SC	Use the internal LVLC power supply of the drive. Use class 2 for external power supply.
Multi-function analog inputs	+V, -V, A1, A2, A3, AC	
Pulse train input	RP, AC	
Pulse train output	MP, AC	
Hardwire Base block inputs	H1, H2, HC	Requires class 2 power supply.
Hardwire Base block monitor outputs	DM+, DM-	

## ■ Drive Short-Circuit Rating

This drive is suitable for use on a circuit capable of delivering not more than 100,000 RMS symmetrical amperes, 600 V ac maximum (Up to 240 V in 200 V class drives, up to 480 V for 400 V class drives), when protected by Busmann Type FWH fuses as specified in [Table D.7](#).

## ◆ Drive Motor Overload Protection

Set parameter E2-01 (motor rated current) to the appropriate value to enable motor overload protection. The internal motor overload protection is UL listed and in accordance with the NEC and CEC.

### ■ E2-01 Motor Rated Current

Setting Range: Model Dependent

Default Setting: Model Dependent

Parameter E2-01 (motor rated current) protects the motor if parameter L1-01 is not set to 0 (default is 1, enabling protection for standard induction motors).

If Auto-Tuning has been performed successfully, the motor data entered to T1-04 is automatically written into parameter E2-01. If Auto-Tuning has not been performed, manually enter the correct motor rated current to parameter E2-01.

### ■ L1-01 Motor Overload Protection Selection

The drive has an electronic overload protection function (oL1) based on time, output current, and output frequency, which protects the motor from overheating. The electronic thermal overload function is UL-recognized, so it does not require an external thermal relay for single motor operation.

This parameter selects the motor overload curve used according to the type of motor applied.

**Table D.9 Overload Protection Settings**

Setting	Description	
0	Disabled	Disabled the drive's internal motor overload protection.
1	Standard fan cooled motor (default)	Selects protection characteristics for a standard self cooled motor with limited cooling capabilities when running below the rated speed. The motor overload detection level (oL1) is automatically reduces when running below the motor rated speed.
2	Drive duty motor with a speed range of 1:10	Selects protection characteristics for a motor with self-cooling capability within a speed range of 10:1. The motor overload detection level (oL1) is automatically reduced when running below 1/10 of the motor rated speed.
3	Vector motor with a speed range of 1:100	Selects protection characteristics for a motor capable of cooling itself at any speed — including zero speed (externally cooled motor). The motor overload detection level (oL1) is constant over the entire speed range.
4	Permanent Magnet motor with variable torque	Selects protection characteristics for a variable torque PM motor. The motor overload detection level (oL1) is automatically reduces when running below the motor rated speed.
5	Permanent Magnet motor with constant torque	Selects protection characteristics for a constant torque PM motor. The motor overload detection level (oL1) is constant over the whole speed range.
6	Standard fan cooled motor (50 Hz)	Selects protection characteristics for a standard self cooled motor with limited cooling capabilities when running below the rated speed. The motor overload detection level (oL1) is automatically reduces when running below the motor rated speed.

When connecting the drive to more than one motor for simultaneous operation, disable the electronic overload protection (L1-01 = 0) and wire each motor with its own motor thermal overload relay.

Enable the motor overload protection (L1-01 = 1 to 6) when connecting the drive to a single motor, unless another motor overload preventing device is installed. The drive electronic thermal overload function causes an oL1 fault, which shuts off the output of the drive and prevents additional overheating of the motor. The motor temperature is continually calculated as long as the drive is powered up.

### ■ L1-02 Motor Overload Protection Time

Setting Range: 0.1 to 5.0 min

Factory Default: 1.0 min

Parameter L1-02 determines how long the motor is allowed to operate before the oL1 fault occurs when the drive is running at 60 Hz and at 150% of the full load amp rating (E2-01) of the motor. Adjusting the value of L1-02 can shift the set of oL1 curves up the y axis of the diagram below, but will not change the shape of the curves.

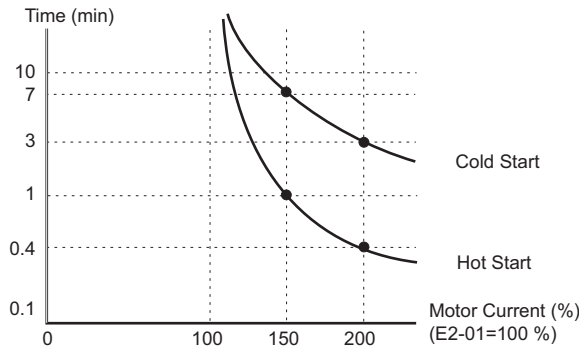


Figure D.7 Motor Overload Protection Time

◆ Precautionary Notes on External Heatsink (IP00 Enclosure)

When using an external heatsink, UL compliance requires that exposed capacitors in the main circuit are covered to prevent injury to surrounding personnel.

The portion of the external heatsink that projects out can either be protected with the enclosure, or with the appropriate capacitor cover after drive installation is complete. Use the table below to match drive models and capacitor cover. Capacitor covers can be ordered from a Yaskawa representative or directly from the Yaskawa sales department. The table below lists available capacitor covers.

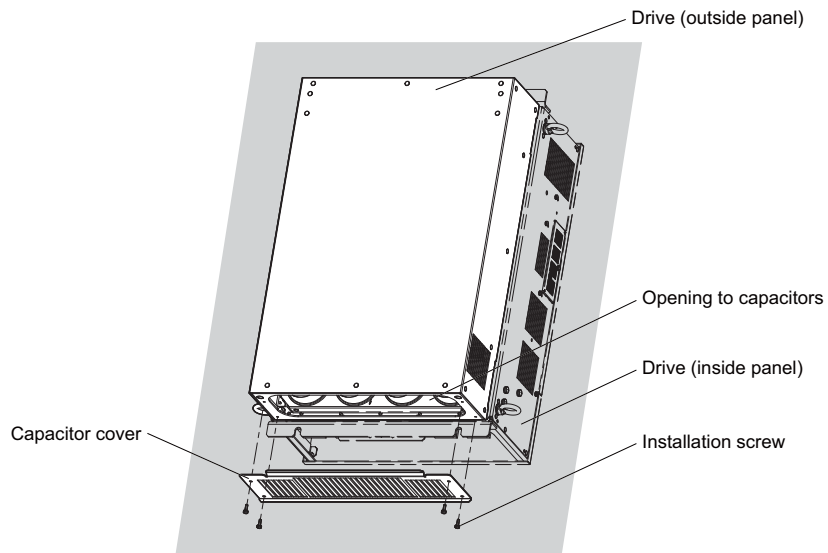
Table D.10 Capacitor Cover

Drive Model CIMR-E□	Code Number	Model	Figure
2A0110	100-061-273	ECAT31875-11	Figure D.8
2A0138	100-061-274	ECAT31876-11	
2A0169	100-061-275	ECAT31877-11	
2A0211			
2A0250	100-061-277	ECAT31726-11	
2A0312			
2A0360	100-061-278	ECAT31698-11	
2A0415			
4A0058	100-061-273	ECAT31875-11	
4A0072	100-061-274	ECAT31876-11	
4A0088	100-061-276	ECAT31878-11	
4A0103			
4A0139	100-061-275	ECAT31877-11	
4A0165			
4A0208	100-061-277	ECAT31726-11	
4A0250	100-061-278	ECAT31698-11	Figure D.8
4A0296			
4A0362			
4A0414	100-061-279	ECAT31740-11	
4A0515	100-061-280	ECAT31746-11	
4A0675			
4A0930	100-061-281 <1>	ECAT31741-11	Figure D.9
4A1200			

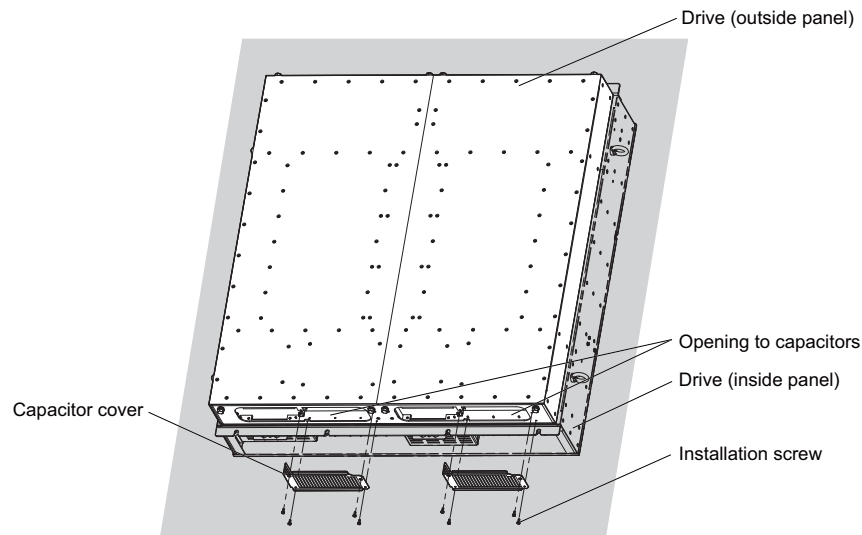
<1> Requires two sets.

**Note:** Model CIMR-E□4A1200 is UL compliant when the air entering the drive-installed panel or cabinet is 45° or less. For more information, contact your nearest Yaskawa representative or our sales office.





**Figure D.8 Capacitor Cover (2A0110 to 2A0415, 4A0068 to 4A0675)**



**Figure D.9 Capacitor Cover (4A0930, 4A1200)**

### D.4 Precautions for Korean Radio Waves Act

Drives that bear the Korea Certification (KC) mark conform to the Korean Radio Waves Act. Be careful if using the drive in Korea under the following conditions.



Figure D.10 KC mark

Classification	Precautions
Class A equipment (Broadcast communications unit for commercial use)	Retailers or users should note that this device is registered to be electromagnetically compatible as a commercial device (class A) intended for use outside of the home.

## D.5 한국 전파법에 관한 주의사항

KC마크가 부착되어 있는 제품은 한국 전파법에 적합한 제품입니다. 한국에서 사용할 경우에는 아래 사항에 주의하여 주십시오.



Figure D.11 KC 마크

기종별	사용자 안내문
A 급 기기 (업무용 방송 통신기 자재)	이 기기는 업무용 (A 급) 전자파 적합 기기로서 판매자 또는, 사용자는 이 점을 주의하시기바라며, 가정외의 지역에서 사용하는 것을 목적으로 합니다.



# Appendix: E

## Quick Reference Sheet

---

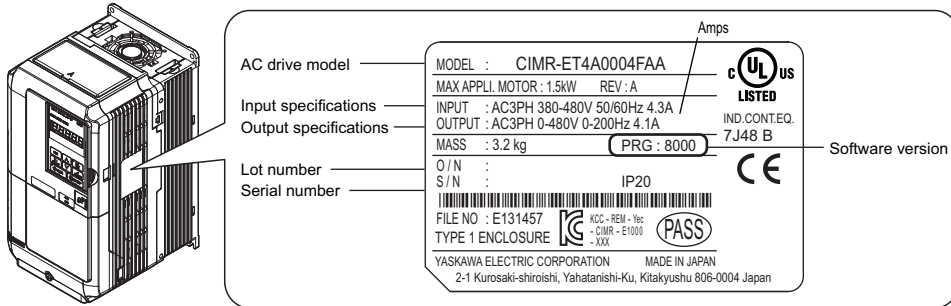
The following tables have been provided for the user's convenience. Fill in the cells that have been left blank as is appropriate for your drive, and keep this information as a quick reference guide to drive and motor data as well as parameter settings

<b>E.1 DRIVE AND MOTOR SPECIFICATIONS</b> .....	<b>462</b>
<b>E.2 MULTI-FUNCTION I/O TERMINAL SETTINGS RECORD</b> .....	<b>463</b>
<b>E.3 USER SETTING TABLE</b> .....	<b>464</b>

# E.1 Drive and Motor Specifications

## ◆ Drive

A separate record should be kept that lists drive specifications and motor specifications.



Items	Description
Model	CIMR-E
Serial Number	
Date of Usage	

## ◆ Motor

### ■ Induction Motor

Items	Description	Items	Description
Manufacturer		Motor Rated Current (T1-04)	A
Model		Motor Base Frequency (T1-05)	Hz
Motor Rated Power (T1-02)	kW	Number of Motor Poles (T1-06)	
Motor Rated Voltage (T1-03)	V	Motor Base Speed (T1-07)	r/min

**Note:** These values must be entered as part of the Auto-Tuning process.

### ■ Permanent Magnet Motor

Items	Description	Items	Description
Manufacturer		PM Motor Rated Current (T2-06)	A
Model		PM Motor Base Frequency (T2-07)	Hz
PM Motor Rated Power (T2-04)	kW	Number of PM Motor Poles (T2-08)	
PM Motor Rated Voltage (T2-05)	V		

**Note:** These values must be entered as part of the Auto-Tuning process.

## E.2 Multi-Function I/O Terminal Settings Record

These tables have been provided for the customer to keep a record of the functions assigned to each multi-function terminal.

### ◆ Multi-Function Digital Inputs (SC Common)

Terminal	Used/Reserved	Setting Value and Function Name	Memo
S1		H1-01=	
S2		H1-02=	
S3		H1-03=	
S4		H1-04=	
S5		H1-05=	
S6		H1-06=	
S7		H1-07=	
S8		H1-08=	

### ◆ Pulse Train Input/Analog Inputs (AC Common)

Terminal	Used/Reserved	Setting Value and Function Name	Memo
RP		H6-01=	
A1		H3-02=	
A2		H3-10=	
A3		H3-06=	

### ◆ Multi-Function Digital Outputs

Terminal	Used/Reserved	Setting Value and Function Name	Memo
M1-M2		H2-01=	
M3-M4		H1-02=	
M5-M6		H1-03=	

### ◆ Monitor Outputs (AC Common)

Terminal	Used/Reserved	Setting Value and Function Name	Memo
FM		H4-01=	
AM		H4-04=	

## E.3 User Setting Table

Use the Verify Menu to see which parameters have been changed from their original default settings.

- The diamond below the parameter number indicates that the parameter setting can be changed during run.
- Parameter names in boldface type are included in the Setup Group of parameters.

No.	Name	User Setting
A1-00◆	Language Selection	
A1-01◆	Access Level Selection	
A1-02	<b>Control Method Selection</b>	
A1-03	Initialize Parameters	
A1-04	Password	
A1-05	Password Setting	
A1-06	Application Preset	
A1-07	DriveWorksEZ Function Selection	
A2-01 to A2-32	User Parameters, 1 to 32	
A2-33	User Parameter Automatic Selection	
b1-01	<b>Frequency Reference Selection 1</b>	
b1-02	<b>Run Command Selection 1</b>	
b1-03	<b>Stopping Method Selection</b>	
b1-04	Reverse Operation Selection	
b1-06	Digital Input Reading	
b1-07	LOCAL/REMOTE Run Selection	
b1-08	Run Command Selection while in Programming Mode	
b1-11	Drive Delay Time Setting	
b1-14	Phase Order Selection	
b1-15	Frequency Reference Selection 2	
b1-16	Run Command Selection 2	
b1-17	Run Command at Power Up	
b2-01	DC Injection Braking Start Frequency	
b2-02	DC Injection Braking Current	
b2-03	DC Injection Braking Time at Start	
b2-04	DC Injection Braking Time at Stop	
b2-09	Motor Pre-Heat Current 2	
b2-12	Short Circuit Brake Time at Start	
b2-13	Short Circuit Brake Time at Stop	
b2-18	Short Circuit Braking Current	
b3-01	Speed Search Selection at Start	
b3-02	Speed Search Deactivation Current	
b3-03	Speed Search Deceleration Time	
b3-04	V/f Gain during Speed Search	
b3-05	Speed Search Delay Time	
b3-06	Output Current 1 during Speed Search	
b3-10	Speed Search Detection Compensation Gain	
b3-14	Bi-Directional Speed Search Selection	
b3-17	Speed Search Restart Current Level	
b3-18	Speed Search Restart Detection Time	
b3-19	Number of Speed Search Restarts	
b3-24	Speed Search Method Selection	
b3-25	Speed Search Wait Time	
b3-27	Start Speed Search Select	
b4-01	Timer Function On-Delay Time	
b4-02	Timer Function Off-Delay Time	
b5-01	PI Function Setting	
b5-02◆	Proportional Gain Setting (P)	
b5-03◆	Integral Time Setting (I)	
b5-04◆	Integral Limit Setting	
b5-06◆	PI Output Limit	
b5-07◆	PI Offset Adjustment	
b5-08◆	PI Primary Delay Time Constant	
b5-09	PI Output Level Selection	
b5-10	PI Output Gain Setting	
b5-11	PI Output Reverse Selection	

No.	Name	User Setting
b5-12	PI Feedback Loss Detection Selection	
b5-13	PI Feedback Loss Detection Level	
b5-14	PI Feedback Loss Detection Time	
b5-15	PI Sleep Function Start Level	
b5-16	PI Sleep Delay Time	
b5-17	PI Accel/Decel Time	
b5-18	PI Setpoint Selection	
b5-19	PI Setpoint Value	
b5-20	PI Setpoint Scaling	
b5-21	PI Sleep Input Source	
b5-22	PI Snooze Level	
b5-23	PI Snooze Delay Time	
b5-24	PI Snooze Deactivation Level	
b5-25	PI Setpoint Boost Setting	
b5-26	PI Maximum Boost Time	
b5-27	PI Snooze Feedback Level	
b5-28	PI Feedback Function Selection	
b5-29	PI Square Root Gain	
b5-30	PI Feedback Offset	
b5-34◆	PI Output Lower Limit	
b5-35◆	PI Input Limit	
b5-36	PI Feedback High Detection Level	
b5-37	PI Feedback High Detection Time	
b5-38	PI Setpoint User Display	
b5-39	PI Setpoint Display Digits	
b5-40	Frequency Reference Monitor Content during PI	
b5-41	PI Unit Selection	
b5-42	PI Output Monitor Calculation Method	
b5-43	Custom PI Output Monitor Setting 1	
b5-44	Custom PI Output Monitor Setting 2	
b5-45	Custom PI Output Monitor Setting 3	
b5-46	PI Setpoint Monitor Unit Selection	
b5-47	Reverse Operation Selection 2 by PI Output	
b8-01	Energy Saving Control Selection	
b8-04	Energy Saving Coefficient Value	
b8-05	Power Detection Filter Time	
b8-06	Search Operation Voltage Limit	
C1-01◆	<b>Acceleration Time 1</b>	
C1-02◆	<b>Deceleration Time 1</b>	
C1-03◆	Acceleration Time 2	
C1-04◆	Deceleration Time 2	
C1-09	Fast-Stop Time	
C1-11	Accel/Decel Time Switching Frequency	
C2-01	S-Curve Characteristic at Accel Start	
C2-02	S-Curve Characteristic at Accel End	
C4-01◆	Torque Compensation Gain	
C4-02◆	Torque Compensation Primary Delay Time	
C6-02	<b>Carrier Frequency Selection</b>	
C6-03	Carrier Frequency Upper Limit	
C6-04	Carrier Frequency Lower Limit	
C6-05	Carrier Frequency Proportional Gain	
d1-01◆	<b>Frequency Reference 1</b>	
d1-02◆	<b>Frequency Reference 2</b>	
d1-03◆	<b>Frequency Reference 3</b>	
d1-04◆	<b>Frequency Reference 4</b>	
d1-17◆	<b>Jog Frequency Reference</b>	



No.	Name	User Setting
d2-01	Frequency Reference Upper Limit	
d2-02	Frequency Reference Lower Limit	
d2-03	Master Speed Reference Lower Limit	
d3-01	Jump Frequency 1	
d3-02	Jump Frequency 2	
d3-03	Jump Frequency 3	
d3-04	Jump Frequency Width	
d4-01	Frequency Reference Hold Function Selection	
d6-01	Field Weakening Level	
d6-02	Field Weakening Frequency Limit	
d7-01◆	Offset Frequency 1	
d7-02◆	Offset Frequency 2	
d7-03◆	Offset Frequency 3	
E1-01	<b>Input Voltage Setting</b>	
E1-03	V/f Pattern Selection	
E1-04	<b>Maximum Output Frequency</b>	
E1-05	<b>Maximum Voltage</b>	
E1-06	<b>Base Frequency</b>	
E1-07	Middle Output Frequency	
E1-08	Middle Output Frequency Voltage	
E1-09	<b>Minimum Output Frequency</b>	
E1-10	Minimum Output Frequency Voltage	
E1-11	Middle Output Frequency 2	
E1-12	Middle Output Frequency Voltage 2	
E1-13	<b>Base Voltage</b>	
E2-01	<b>Motor Rated Current</b>	
E2-02	Motor Rated Slip	
E2-03	Motor No-Load Current	
E2-04	Number of Motor Poles	
E2-05	Motor Line-to-Line Resistance	
E2-10	Motor Iron Loss for Torque Compensation	
E2-11	<b>Motor Rated Output</b>	
E5-01	Motor Code Selection	
E5-02	Motor Rated Power	
E5-03	Motor Rated Current	
E5-04	Number of Motor Poles	
E5-05	Motor Stator Resistance	
E5-06	Motor d-Axis Inductance	
E5-07	Motor q-Axis Inductance	
E5-09	Motor Induction Voltage Constant 1	
E5-24	Motor Induction Voltage Constant 2	
E5-25	Polarity Judge Selection	
F6-01	Communications Error Operation Selection	
F6-02	External Fault from Comm. Option Detection Selection	
F6-03	External Fault from Comm. Option Operation Selection	
F6-04	bUS Error Detection Time	
F6-07	NetRef/ComRef Function Selection	
F6-08	Reset Communication Parameters	
F6-10	CC-Link Node Address	
F6-11	CC-Link Communications Speed	
F6-14	CC-Link bUS Error Auto Reset	
F6-20	MECHATROLINK Station Address	
F6-21	MECHATROLINK Frame Size	
F6-22	MECHATROLINK Link Speed	
F6-23	MECHATROLINK Monitor Selection (E)	
F6-24	MECHATROLINK Monitor Selection (F)	
F6-25	Operation Selection at Watchdog Timer Error (E5)	
F6-26	MECHATROLINK bUS Errors Detected	
F6-30	PROFIBUS-DP Node Address	
F6-31	PROFIBUS-DP Clear Mode Selection	
F6-32	PROFIBUS-DP Data Format Selection	
F6-35	CANopen Node ID Selection	
F6-36	CANopen Communication Speed	
F6-50	DeviceNet MAC Address	
F6-51	DeviceNet Communication Speed	

No.	Name	User Setting
F6-52	DeviceNet PCA Setting	
F6-53	DeviceNet PPA Setting	
F6-54	DeviceNet Idle Mode Fault Detection	
F6-55	DeviceNet Baud Rate Monitor	
F6-56	DeviceNet Speed Scaling	
F6-57	DeviceNet Current Scaling	
F6-58	DeviceNet Torque Scaling	
F6-59	DeviceNet Power Scaling	
F6-60	DeviceNet Voltage Scaling	
F6-61	DeviceNet Time Scaling	
F6-62	DeviceNet Heartbeat Interval	
F6-63	DeviceNet Network MAC ID	
H1-01	Multi-Function Digital Input Terminal S1 Function Selection	
H1-02	Multi-Function Digital Input Terminal S2 Function Selection	
H1-03	Multi-Function Digital Input Terminal S3 Function Selection	
H1-04	Multi-Function Digital Input Terminal S4 Function Selection	
H1-05	Multi-Function Digital Input Terminal S5 Function Selection	
H1-06	Multi-Function Digital Input Terminal S6 Function Selection	
H1-07	Multi-Function Digital Input Terminal S7 Function Selection	
H1-08	Multi-Function Digital Input Terminal S8 Function Selection	
H2-01	Terminal M1-M2 Function Selection (relay)	
H2-02	Terminal M3-M4 Function Selection (photocoupler)	
H2-03	Terminal M5-M6 Function Selection (photocoupler)	
H2-06	Watt Hour Output Unit Selection	
H3-01	Terminal A1 Signal Level Selection	
H3-02	Terminal A1 Function Selection	
H3-03◆	Terminal A1 Gain Setting	
H3-04◆	Terminal A1 Bias Setting	
H3-05	Terminal A3 Signal Level Selection	
H3-06	Terminal A3 Function Selection	
H3-07◆	Terminal A3 Gain Setting	
H3-08◆	Terminal A3 Bias Setting	
H3-09	Terminal A2 Signal Level Selection	
H3-10	Terminal A2 Function Selection	
H3-11◆	Terminal A2 Gain Setting	
H3-12◆	Terminal A2 Bias Setting	
H3-13	Analog Input Filter Time Constant	
H3-14	Analog Input Terminal Enable Selection	
H3-16	Terminal A1 Offset	
H3-17	Terminal A2 Offset	
H3-18	Terminal A3 Offset	
H4-01	Multi-Function Analog Output Terminal FM Monitor Selection	
H4-02◆	<b>Multi-Function Analog Output Terminal FM Gain</b>	
H4-03◆	Multi-Function Analog Output Terminal FM Bias	
H4-04	Multi-Function Analog Output Terminal AM Monitor Selection	
H4-05◆	Multi-Function Analog Output Terminal AM Gain	
H4-06◆	Multi-Function Analog Output Terminal AM Bias	
H4-07	Multi-Function Analog Output Terminal FM Signal Level Selection	
H4-08	Multi-Function Analog Output Terminal AM Signal Level Selection	
H5-01	Drive Node Address	
H5-02	Communication Speed Selection	
H5-03	Communication Parity Selection	
H5-04	Stopping Method After Communication Error (CE)	
H5-05	Communication Fault Detection Selection	
H5-06	Drive Transmit Wait Time	
H5-07	RTS Control Selection	

## E.3 User Setting Table

No.	Name	User Setting
H5-09	CE Detection Time	
H5-10	Unit Selection for MEMOBUS/Modbus Register 0025H	
H5-11	Communications ENTER Function Selection	
H5-12	Run Command Method Selection	
H6-01	Pulse Train Input Terminal RP Function Selection	
H6-02◆	Pulse Train Input Scaling	
H6-03◆	Pulse Train Input Gain	
H6-04◆	Pulse Train Input Bias	
H6-05◆	Pulse Train Input Filter Time	
H6-06◆	Pulse Train Monitor Selection	
H6-07◆	Pulse Train Monitor Scaling	
H6-08	Pulse Train Input Minimum Frequency	
L1-01	Motor Overload Protection Selection	
L1-02	Motor Overload Protection Time	
L1-03	Motor Overheat Alarm Operation Selection (PTC input)	
L1-04	Motor Overheat Fault Operation Selection (PTC input)	
L1-05	Motor Temperature Input Filter Time (PTC input)	
L1-13	Continuous Electrothermal Operation Selection	
L1-15	Motor 1 Thermistor Selection (NTC)	
L1-16	Motor 1 Overheat Temperature	
L1-19	Operation at Thermistor Disconnect (THo) (NTC)	
L1-20	Operation at Motor Overheat (oH5)	
L2-01	Momentary Power Loss Operation Selection	
L2-02	Momentary Power Loss Ride-Thru Time	
L2-03	Momentary Power Loss Minimum Baseblock Time	
L2-04	Momentary Power Loss Voltage Recovery Ramp Time	
L2-05	Undervoltage Detection Level (Uv1)	
L2-06	KEB Deceleration Time	
L2-07	KEB Acceleration Time	
L2-08	Frequency Gain at KEB Start	
L2-10	KEB Detection Time	
L2-11	DC Bus Voltage Setpoint During KEB	
L2-29	KEB Method Selection	
L3-01	Stall Prevention Selection during Acceleration	
L3-02	Stall Prevention Level during Acceleration	
L3-03	Stall Prevention Limit during Acceleration	
L3-04	<b>Stall Prevention Selection during Deceleration</b>	
L3-05	Stall Prevention Selection during Run	
L3-06	Stall Prevention Level during Run	
L3-11	Overvoltage Suppression Function Selection	
L3-17	Target DC Bus Voltage for Overvoltage Suppression and Stall Prevention	
L3-20	DC Bus Voltage Adjustment Gain	
L3-21	Accel/Decel Rate Calculation Gain	
L3-22	Deceleration Time at Stall Prevention during Acceleration	
L3-23	Automatic Reduction Selection for Stall Prevention during Run	
L3-24	Motor Acceleration Time for Inertia Calculations	
L3-25	Load Inertia Ratio	
L3-26	Additional DC Bus Capacitors	
L3-27	Stall Prevention Detection Time	
L4-01	Speed Agreement Detection Level	
L4-02	Speed Agreement Detection Width	
L4-03	Speed Agreement Detection Level (+/-)	
L4-04	Speed Agreement Detection Width (+/-)	
L4-05	Frequency Reference Loss Detection Selection	
L4-06	Frequency Reference at Reference Loss	
L4-07	Speed Agreement Detection Selection	
L5-01	Number of Auto Restart Attempts	
L5-02	Auto Restart Fault Output Operation Selection	
L5-04	Fault Reset Interval Time	
L5-05	Fault Reset Operation Selection	
L6-01	Torque Detection Selection	
L6-02	Torque Detection Level	
L6-03	Torque Detection Time	
L6-13	Motor Underload Protection Selection	

No.	Name	User Setting
L6-14	Motor Underload Protection Level at Minimum Frequency	
L8-02	Overheat Alarm Level	
L8-03	Overheat Pre-Alarm Operation Selection	
L8-05	Input Phase Loss Protection Selection	
L8-06	Input Phase Detection Level	
L8-07	Output Phase Loss Protection	
L8-09	Output Ground Fault Detection Selection	
L8-10	Heatsink Cooling Fan Operation Selection	
L8-11	Heatsink Cooling Fan Off Delay Time	
L8-12	Ambient Temperature Setting	
L8-15	oL2 Characteristics Selection at Low Speeds	
L8-18	Software Current Limit Selection	
L8-19	Frequency Reduction Rate during Overheat Pre-Alarm	
L8-27	Overcurrent Detection Gain	
L8-29	Current Unbalance Detection (LF2)	
L8-32	Current Unbalance Detection Current Level	
L8-35	Installation Method Selection	
L8-38	Carrier Frequency Reduction Selection	
L8-40	Carrier Frequency Reduction Off Delay Time	
L8-41	High Current Alarm Selection	
L8-78	Power Unit Output Phase Loss Protection	
n1-01	Hunting Prevention Selection	
n1-02	Hunting Prevention Gain Setting	
n1-03	Hunting Prevention Time Constant	
n1-05	Hunting Prevention Gain while in Reverse	
n3-01	High Slip Braking Deceleration Frequency Width	
n3-02	High Slip Braking Current Limit	
n3-03	High Slip Braking Dwell Time at Stop	
n3-04	High Slip Braking Overload Time	
n3-13	Overexcitation Deceleration Gain	
n3-21	High-Slip Suppression Current Level	
n3-23	Overexcitation Operation Selection	
n8-45	Speed Feedback Detection Control Gain	
n8-47	Pull-In Current Compensation Time Constant	
n8-48	Pull-In Current	
n8-49	d-Axis Current for High Efficiency Control	
n8-51	Acceleration/Deceleration Pull-In Current	
n8-54	Voltage Error Compensation Time Constant	
n8-55	Load Inertia	
n8-62	Output Voltage Limit	
n8-65	Speed Feedback Detection Control Gain during ov Suppression	
o1-01◆	Drive Mode Unit Monitor Selection	
o1-02◆	User Monitor Selection After Power Up	
o1-03	Digital Operator Display Selection	
o1-06	User Monitor Selection Mode	
o1-07	Second Line Monitor Selection	
o1-08	Third Line Monitor Selection	
o1-10	User-Set Display Units Maximum Value	
o1-11	User-Set Display Units Decimal Display	
o2-01	LO/RE Key Function Selection	
o2-02	STOP Key Function Selection	
o2-03	User Parameter Default Value	
o2-04	Drive Model Selection	
o2-05	Frequency Reference Setting Method Selection	
o2-06	Operation Selection when Digital Operator is Disconnected	
o2-07	Motor Direction at Power Up when Using Operator	
o3-01	Copy Function Selection	
o3-02	Copy Allowed Selection	
o4-01	Cumulative Operation Time Setting	
o4-02	Cumulative Operation Time Selection	
o4-03	Cooling Fan Maintenance Operation Time Setting	
o4-05	Capacitor Maintenance Setting	
o4-07	DC Bus Pre-charge Relay Maintenance Setting	
o4-09	IGBT Maintenance Setting	

No.	Name	User Setting
o4-11	U2, U3 Initialize Selection	
o4-12	kWh Monitor Initialization	
o4-13	Number of Run Commands Counter Initialization	
q1-01 to q6-07	DriveWorksEZ Parameters	
r1-01 to r1-40	DriveWorksEZ Connection Parameter 1 to 20 (upper/lower)	
T1-01	Auto-Tuning Mode Selection	
T1-02	Motor Rated Power	
T1-03	Motor Rated Voltage	
T1-04	Motor Rated Current	
T1-05	Motor Base Frequency	
T1-06	Number of Motor Poles	
T1-07	Motor Base Speed	
T1-11	Motor Iron Loss	
T2-01	PM Motor Auto-Tuning Mode Selection	
T2-02	PM Motor Code Selection	
T2-03	PM Motor Type	
T2-04	PM Motor Rated Power	
T2-05	PM Motor Rated Voltage	
T2-06	PM Motor Rated Current	
T2-07	PM Motor Base Frequency	
T2-08	Number of PM Motor Poles	
T2-10	PM Motor Stator Resistance	
T2-11	PM Motor d-Axis Inductance	
T2-12	PM Motor q-Axis Inductance	
T2-13	Induced Voltage Constant Unit Selection	
T2-14	PM Motor Induced Voltage Constant	
T2-15	Pull-In Current Level for PM Motor Tuning	

# Index

## Symbols

-	72
+1	72
+2	72
+3	72
+V	80

## Numerics

1800 r/min Type YASKAWA SMRA Series SPM Motor Settings	404
24 V Power Supply	334
2-Wire Initialization	127
3600 r/min Type YASKAWA SMRA Series SPM Motor Settings	404
3-Wire Initialization	127
3-Wire Sequence	182
3-Wire Sequence Wiring Diagram	182
5th Most Recent Fault	394

## A

A/D Conversion Error	261, 265
A1	80
A1-02 (Motor 1 Control Mode) Dependent Parameters	398
A2	80
A3	80
AC	80, 81
AC Reactor	333
Accel/Decel Rate Calculation Gain	226
Accel/Decel Time	259, 352
Accel/Decel Time Switching Frequency	161
Acceleration Error	263, 284
Acceleration Time	160
Acceleration Time Pull-In Current	388
Acceleration/Deceleration Pull-In Current	244
Access Level Selection	122, 126
Additional DC Bus Capacitors	227
Adjusted Slip Calculation Error	283
AER	275
Air Filter	325
Alarm	263
Alarm Outputs for Maintenance Monitors	301
Alarm Register 007FH Contents	433
Alarms and Errors	260
Allowable Frequency Fluctuation	350, 351
Allowable Voltage Fluctuation	350, 351
ALM LED Light	97
Altitude	44
AM	81
Ambient Temperature	44
Ambient Temperature and Installation Method Derating	356
Ambient Temperature Setting	236, 355, 386
Analog Filter Time Constant	259
Analog Frequency Reference Sample/Hold	186
Analog Input Filter Time Constant	201
Analog Input Terminal Enable Selection	202
Analog Inputs / Pulse Train Input	80
Application Notes	18
Application Presets	111
Application Selection	111
Applications with Specialized Motors	21
Attachment for External Heatsink	334, 346
Auto Restart Fault Output Operation Selection	229
Auto Restart Operation Selection	385
Automatic Reduction Selection for Stall Prevention	

during Run	224, 384
Auto-Tuning	113, 114, 116
Auto-Tuning Codes	283
Auto-Tuning Error Displays	263
Auto-Tuning Errors	263
Auto-Tuning Fault Codes	115
Auto-Tuning Fault Detection	283
Auto-Tuning Fault Solutions	283
Auto-Tuning for Induction Motors	113
Auto-Tuning for Permanent Magnet Motors	113
Auto-Tuning Input Data	113, 114
Auto-Tuning Interruption and Fault Codes	115
Auto-Tuning Mode Selection	116, 390

## B

Backing Up Parameter Values	122
Base Frequency	174, 271
Base Voltage	174
Baseblock	275
Basic Auto-Tuning Preparations	114
Basic Start-up and Motor Tuning	107
bb	262, 275
Before Auto-Tuning the Drive	114
Bi-Directional Speed Search Selection	143
boL	265
Bottom Cover	32
Braking Resistor	340
Braking Resistor Unit	333
Braking Torque	352
Braking Transistor Overload Fault	265
Braking Unit	333
Broadcast Messages	432
bUS	261, 262, 265, 275
Buzzing Sound from Motor at 2 kHz	293

## C

Cable Length Between Drive and Motor	77
CALL	262, 275
Cannot Change Parameter Settings	289
Cannot Reset	262, 276
CANopen Parameters	179, 180
Capacitor Maintenance	395
Capacitor Maintenance Setting	250, 389
Capacitor Maintenance Time	277
Carrier Frequency	163, 350, 351
Carrier Frequency and Current Derating	164
Carrier Frequency Derating	354
Carrier Frequency Lower Limit	163
Carrier Frequency Proportional Gain	163
Carrier Frequency Reduction	386
Carrier Frequency Reduction Off-Delay Time	238
Carrier Frequency Reduction Selection	238
Carrier Frequency Selection	163, 258
Carrier Frequency Setting Error	263, 281
Carrier Frequency Upper Limit	163
CC-Link Parameters	179, 180
CE	261, 262, 265, 275
CE Detection Time	417
CE Low Voltage Directive Compliance	440
CE mark	440
Changing Parameter Settings or Values	103
Circulation fan	35, 36, 37, 38
Coast to stop	133
Coast to Stop with Timer	134
Command Messages from Master to Drive	420
Communication Error	285
Communication Fault Detection Selection	417
Communication Option Card	179

Communication Option Card Reference	396
Communication Option Station Number Setting Error (CC-Link, CANopen, MECHATROLINK-II)	275
Communication Parity Selection	416
Communication Speed Selection	416
Communications Enter Function Selection	418
Communications Error Operation Selection	179
Communications Timing	420
Comparing Parameter Settings	286
Component Names	32
Compressor Application	112
Connected Machinery Vibrates When Motor Rotates	293
Connecting a DC Reactor	343
Connecting a Noise Filter	343
Connecting a Suppression Diode	81
Connecting a Surge Absorber	343
Connecting an AC Reactor	343
Connecting Braking Units in Parallel	341
Connecting Peripheral Devices	335
Connecting to a PC (USB)	89
Connection of a Motor PTC	211
Continuous Electrothermal Operation Selection	212
Control Board Connection Error	265, 266
Control Circuit Connection Diagram	79
Control Circuit Error	265, 266
Control Circuit Fault	261
Control Circuit Input Terminals	80
Control Circuit Output Terminals	81
Control Circuit Terminal Arrangement	82
Control Circuit Terminal Block Functions	80
Control Circuit Wiring	79
Control Dial for Frequency Setting Potentiometer	333
Control Method Selection	126
Control Mode	126, 392
Control Mode Dependent Parameter Default Values	398
Control Mode Mismatch	285
Control Mode Selection	28
Control Modes and their Features	28
Control Monitors	397
Control Power Supply Undervoltage	262
Control Power Supply Voltage Fault	274
Cooling Fan	32, 33, 34, 35, 36, 37, 38
Cooling Fan Maintenance	395
Cooling Fan Maintenance Setting (Operation Time)	389
Cooling Fan Maintenance Time	277
Cooling Fan Operation Time	395
Cooling Fan Operation Time Setting	250
Cooling Fan Replacement	303
CoPy	285
Copy Allowed Selection	250
Copy Errors	263
Copy Function	123, 249
Copy Function Errors	260
Copy Function Selection	249
Copy Unit Error	285
CopyUnitManager	123
CPEr	285
CPF02	265
CPF03	265
CPF06	266
CPF07	266
CPF08	266
CPF11 to CPF14	265
CPF20	261, 266
CPF21	261, 266
CPF22	261, 266
CPF23	261, 266
CPF24	261, 266
CPF25	261, 266
CPF26	266
CPF35	266
CPyE	285
CRC-16	421
CRC-16 Checksum Calculation Example	422
CrST	262, 276
CSEr	285
Cumulative Operation Time	394
Cumulative Operation Time at 5th Most Recent Fault	394
Cumulative Operation Time at Most Recent Fault	394
Cumulative Operation Time at Previous Fault	394
Cumulative Operation Time Selection	250, 389
Cumulative Operation Time Setting	250, 389
Current Alarm	262, 277
Current Detection Error	263, 284
Current Detection Speed Search	139
Current Fault	393
Current Imbalance	262
Current Unbalance Detection (LF2)	237, 386
Cyclic Redundancy Check	421
<b>D</b>	
d References	367
Daily Inspection	299
d-Axis Current for High Efficiency Control	243
DC Bus Overvoltage	278
DC Bus Pre-Charge Relay Maintenance Setting	251
DC Bus Undervoltage	273
DC Bus Voltage	392
DC Bus Voltage Adjustment Gain	225
DC Bus Voltage at Previous Fault	393
DC Bus Voltage Setpoint during KEB	220
DC Injection Braking at Stop	293
DC Injection Braking Current	138, 293
DC Injection Braking Input Timing Diagram	188
DC Injection Braking Start Frequency	137
DC Injection Braking Time at Start	138
DC Injection Braking Time at Stop	138
DC Injection Braking to Stop	134
DC Reactor	333
DC Reactors for EN 61000-3-2 Compliance	445
Deceleration Rate Calculation Gain	384
Deceleration Time	160
Deceleration Time at Stall Prevention during Acceleration	223, 384
Defaults by Drive Model Selection (o2-04)	400
Delay Timers	144
Desired DC Bus Voltage during KEB	383
DeviceNet Parameters	179, 180
dFPS	285
Diagnosing and Resetting Faults	287
Digital Input Reading	135
Digital Operator	32, 33, 34, 35, 36, 37, 38, 97, 98
Digital Operator Dimensions	47
Digital Operator Display Selection	246, 388
Digital Operator Installation Methods and Required Tools	48
Digital Operator Keypad Functions	247
Digital Operator Menu and Screen Structure	100
Digital Operator Remote Installation	47
Digital Operator Remote Usage	47
Digital Text Display	98
Dimensions for IP00 Enclosure	
200 V Class	52
400 V Class	53
Dimensions for IP20/NEMA Type 1 Enclosure	

200 V Class	50	EF	262, 276
400 V Class	51	EF0	261, 267, 276
DIP Switch S1	39	EF1	267, 276
DIP Switch S1 Settings	86, 88	EF1 to EF7	261, 262
DIP Switch S2	39, 90, 415	EF2	267, 276
DIP Switch S4 Settings	87	EF3	267, 276
DM-	81	EF4	267, 276
DM+	81	EF5	267, 276
dnE	262, 276	EF6	267, 276
Drive Baseblock	262	EF7	267, 276
Drive Capacity Setting Fault	280	EF8	267, 276
Drive Capacity Signal Fault	261	ELCB	333
Drive Cooling Fans	303	Electrical Installation	55
Drive Cover	33, 34, 35	EMC Filter and Drive Installation for CE Compliance	443
Drive Cover 1	36, 37, 38	EMC Filter Installation	441
Drive cover 2	37	EMC Filters	444
Drive Derating Data	354	EMC Guidelines	440
Drive Disabled	262, 276	EMC Guidelines Compliance	441
Drive Does Not Allow Selection of Rotational Auto-Tuning	291	EN61800-3 C2 Filters	444
Drive Mode	101, 102	Enclosure Types	31
Drive Mode Unit Monitor Selection	246, 388	End	285
Drive Model Mismatch	285	End1	263, 283
Drive Model Selection	248	End3	263, 283
Drive Models and Types	49	End4	283
Drive Motor Overload Protection	455	End5	283
Drive Operation Status at Previous Fault	394	End7	283
Drive Overheat	262	Energy Saving	158
Drive Overheat Warning	278	Energy Saving Coefficient Value	158
Drive Overload	261, 271	Energy Saving Control Selection	158
Drive Ready	91	Enter Command	434
Drive Replacement	327	Enter command necessary	418
Drive Short-Circuit Rating	455	Enter command not necessary	418
Drive Slave Address	416	Enter Command Types	434
Drive Specifications	352	Enter Data from the Motor Nameplate	115
Drive Standard Connection Diagram	59	Er-01	263, 283
Drive Status	392	Er-02	263, 283
Drive Transmit Wait Time	417	Er-03	263, 283
Drive Unit Setting Error	263	Er-04	263, 284
Drive Unit Signal Fault	266	Er-05	263, 284
Drive Watt Loss Data	353	Er-08	263, 284
Drive/kVA Selection	389	Er-09	263, 284
DriveWizard Plus	123, 334	Er-11	263, 284
DriveWorksEZ	334	Er-12	263, 284
DriveWorksEZ Connection Parameters	252	Err	261, 267
DriveWorksEZ Custom Monitor 1 to 10	397	Error Reading Data	286
DriveWorksEZ Fault	266	Error Writing Data	285
DriveWorksEZ Function Selection	129	Errors and Displays When Using the Copy Function	263
DriveWorksEZ Monitors	254	European Standards	440
DriveWorksEZ Parameters	252	Excessive Motor Oscillation and Erratic Rotation	292
DRV LED Light	97	Excessive PI Feedback	261, 262, 267, 276
During Frequency Output Time Chart	197	Excessive V/f Setting	263, 283
During Run Time Chart	191	Exhaust Fan Application	111
dv7	266	Exterior and Mounting Dimensions	49
dWAL	262, 266	External Digital Operator Connection Fault	272
Dwell Function	259	External Fault	267, 276
DWEZ Connection Parameters	390	External Fault (input terminal S1 to S7)	261, 262
DWEZ Version Control Monitor 1 to 3	397	External Fault from Comm. Option Detection Selection	179
dWFL	266	External Fault from Comm. Option Operation Selection	179
Dynamic Braking Options	340	External Interlock	91
<b>E</b>		<b>F</b>	
E (G)	80	Fan Connector Cable (CN6)	311
E1000 Models	27	Fan Cover	32, 33, 304
Earth Leakage Circuit Breaker	333	Fan Guard	34, 35, 36, 37, 38, 312
EEPROM Memory Data Error	266	Fan Relay Cable	311
EEPROM Write Error	261, 267	Fan Unit	34, 35, 36, 37, 311
		Fan Unit Case	38

Fast Stop Sequence	186
Fast Stop Time	161
Fault Causes and Solutions	265
Fault Detection	265
Fault Displays	261, 265
Fault History	253, 287, 394
Fault Relay	81
Fault Reset Interval Time	229, 230, 385
Fault Reset Methods	288
Fault Reset Operation Selection	230, 385
Fault Restart	228
Fault Trace	253, 287, 393
Fault Trace / History Register Contents	432
Fault Trace Example	287
Faults	260, 261
FbH	261, 262, 267, 276
FbL	261, 262, 268, 277
Ferrule Dimensions	82
Ferrule Terminal Types and Sizes	82
Ferrule-Type Wire Terminals	82
Field Forcing	169
Field Weakening	169
Field Weakening Frequency Limit	169
Field Weakening Level	169
Fine-Tuning Open Loop Vector Control for PM Motors	258
Fine-Tuning V/f Control	258
FJOG/RJOG Operation	185
FM	81
Formula to calculate the amount of voltage drop	73
Forward/Reverse Run Command Input Error	276
FOUT LED Light	97
Frequency Accuracy (Temperature Fluctuation)	352
Frequency Control Range	352
Frequency Detection 1 Time Chart	192
Frequency Detection 2 Time Chart	193
Frequency Detection 3 Example with a Positive L3-04 Value	195
Frequency Detection 4 Example with Positive L3-04 Value	196
Frequency Gain at KEB Start	220
Frequency Meter / Ammeter	333
Frequency Meter Potentiometer	333
Frequency Reduction Rate during Overheat Pre-Alarm	234, 386
Frequency Reference	165, 391
Frequency Reference at Previous Fault	393
Frequency Reference at Reference Loss	228, 384
Frequency Reference from MEMOBUS/Modbus Comm.	395
Frequency Reference Hold	167
Frequency Reference Hold Function Selection	167
Frequency Reference Loss Detection Selection	228, 384
Frequency Reference Lower Limit	166
Frequency Reference Monitor Content During PI	155
Frequency Reference Selection	361
Frequency Reference Selection 1	131, 290
Frequency Reference Selection 2	137
Frequency Reference Setting / Decimal Display	388
Frequency Reference Setting and User-Set Display	388
Frequency Reference Setting Hierarchy	165
Frequency Reference Setting Method Selection	249, 389
Frequency Reference Source Selection	395
Frequency Reference Upper Limit	166
Frequency Setting Potentiometer	333
Frequency Setting Resolution	352
Frequency Setting Signal	352
Front Cover	32, 33, 34, 35, 36, 37, 38
Front Cover Screw	33, 34, 35, 36, 37, 38
Function Code	421
Functions for Terminals S1 to S8	181
Fuse	333, 345
Fuse Holder	345
Fuse Selection	440, 453
<b>G</b>	
General Safety Information	15
GF	261, 268
Ground Fault	261, 268
Ground Terminal	39
Ground Wiring	78
<b>H</b>	
H1	80
H1 Multi-Function Digital Input Selections	373
H2	80
H3 Multi-Function Analog Input Settings	379
Hardwire Baseblock Input Sink / Source / External Power Supply Selection	85
HC	80
HCA	262, 277
Heatsink	32, 33, 34, 35, 36, 37, 38
Heatsink Cooling Fan Off-Delay Time	236
Heatsink Cooling Fan Operation Delay Time	386
Heatsink Cooling Fan Operation Selection	236, 386
Heatsink Overheat	261, 262, 270, 278
Heatsink Temperature	395
High Current Alarm Selection	238
High Slip Braking	241, 272
High Slip Braking Current Limit	241, 387
High Slip Braking Deceleration Frequency Width	241, 387
High Slip Braking Dwell Time at Stop	241, 387
High Slip Braking oL	261, 272
High Slip Braking Overload Time	241, 272, 387
High Slip Suppression Current Level	242, 387
HSB	241
Humidity	44
Hunting Prevention	240
Hunting Prevention Gain	258
Hunting Prevention Gain Setting	240, 387
Hunting Prevention Gain while in Reverse	240, 387
Hunting Prevention Selection	240, 387
Hunting Prevention Time Constant	240, 387
HVAC Fan Application	112
<b>I</b>	
I Control	145
iFEr	285
IG	81
IGBT Maintenance	395
IGBT Maintenance Setting	251, 389
IGBT Maintenance Time (50%)	277
IGBT Maintenance Time (90%)	279
Induced Noise	344
Induced Voltage Constant Unit Selection	119
Initial Operation	107
Initialization	126
Initialization required	280
Initialize Parameters	122, 127
Input Current	350, 351
Input Fuses	345, 440, 453
Input Noise Filter	333
Input Phase Loss	261, 272
Input Phase Loss Protection Selection	235, 385
Input Power	350, 351
Input Pulse Monitor	393
Input Terminal Status	392

Input Terminal Status at Previous Fault	394	LO/RE LED	99
Input Terminals	106	LO/RE Light	97
Input Voltage Setting	170	Load Current	388
Inrush Prevention Circuit Fault	274	Load Inertia	244, 388
Inrush Prevention Relay Maintenance Setting	389	Load Inertia Ratio	226, 272, 384
Inspection	299, 300	LOCAL	106
Installation Environment	44	LOCAL/REMOTE Key Function Selection	389
Installation Method Selection	237	LOCAL/REMOTE Run Selection	135
Installation Orientation	44	Locations of Jumpers and Switches on the Terminal Board	84
Installation Orientation and Spacing	44	Loopback Test	423
Installation Spacing	45	Loss of Reference Function	228, 230
Installing a Braking Unit: CDBR Type	340	Low Voltage Directive	440
Installing a Leakage Breaker	342	Low Voltage Wiring	454
Installing a Magnetic Contactor	342	Low Voltage Wiring for Control Circuit Terminals	454
Installing a Molded Case Circuit Breaker (MCCB)	341	LT-1	277
Installing a Motor Thermal Overload (oL) Relay on the Drive Output	346	LT-2	277
Installing Peripheral Devices	340	LT-3	277
Installing the Cooling Fan	306, 308, 314	LT-4	277
Integral Limit Setting	148	<b>M</b>	
Integral Time Setting (I)	148	M1	81
Interlock Circuit Example	91	M2	81
IP00 Enclosure	31	M3	81
IP20/NEMA Type 1 Enclosure	31	M4	81
Isolator	333	M5	81
<b>J</b>		M6	81
Jog Frequency Reference	165	MA	81
Jump Frequency	167, 259	Magnetic Contactor (Input)	333
Jump Frequency Width	167	Main Circuit Connection Diagram	61, 78
Jumper S5 Settings	87	Main Circuit Terminal	39
<b>K</b>		Main Circuit Terminal and Motor Wiring	77
KC	458	Main Circuit Terminal Block Configuration	65
KEB Acceleration Time	220, 383	Main Circuit Terminal Functions	72, 346
KEB Deceleration Time	220, 383	Main Circuit Terminal Wiring	78
KEB Detection Time	220	Main Circuit Wiring	72
KEB Function Related Adjustments	218	Main Power Circuit Voltage Adjustment Gain	384
KEB Method Selection	220	Maintenance	301, 302
KEB Operation Using a KEB Input	216	Maintenance Alarms	302
KEB Operation Using L2-02 and KEB Input	217	Maintenance Monitor Settings	250
KEB Operation Using L2-02, Without KEB Input	216	Maintenance Monitors	253, 394
KEB Operation Using L2-10 and KEB Input	218	Master Speed Reference Lower Limit	167
KEB Operation Using L2-10, Without KEB Input	217	Max. Motor Capacity	30
KEB Operation Wiring Example	218	Maximum Applicable Motor Capacity	350, 351
KEB Ride-Thru End Detection	216	Maximum Output Frequency	174, 350, 351
KEB Ride-Thru Function	215	Maximum Output Voltage	350, 351
KEB Ride-Thru Start	216	Maximum Voltage	174
KEB Start Output Frequency Reduction	383	MB	81
Keys and Displays on the Digital Operator	97	MC	81
Korean Radio Waves Act	458	Mechanical Installation	41
kWh	395	MECHATROLINK Parameters	180
kWh Monitor Initial Value Selection	390	MEMOBUS/Modbus Comm. Test Mode Complete	278
kWh Monitor Initialization	251	MEMOBUS/Modbus Communication	81
kWh, Lower 4 Digits	395	MEMOBUS/Modbus Communication	
kWh, Upper 5 Digits	395	Error	261, 262, 265, 275
<b>L</b>		MEMOBUS/Modbus Communication Test Mode Error	279
L Protection Function	382	MEMOBUS/Modbus Communications	411
Language Selection	126	MEMOBUS/Modbus Communications Reference	396
LCD Operator	334	MEMOBUS/Modbus Data Table	425
LED Check	395	MEMOBUS/Modbus Error Code	393
LED Screen Displays	98	MEMOBUS/Modbus Error Codes	435
LF	261, 268	MEMOBUS/Modbus Setup Parameters	416
LF2	262, 268	MEMOBUS/Modbus Specifications	413
Line-to-Line Resistance Error	263, 284	MEMOBUS/Modbus Switch Settings	87, 90
LO/RE	99, 106, 120	MEMOBUS/Modbus Termination	87, 90
LO/RE (LOCAL/REMOTE) Key Function Selection	247	MEMOBUS/Modbus Test Mode Complete	263
		Menu Structure for Digital Operator	100
		Message Format	421



Meter Plate	333	Coefficient	211
Mid Output Voltage A	258	Motor PTC Characteristics	211
Middle Output Frequency	174	Motor Pull Out or Step Out Detection	273
Middle Output Frequency 2	174	Motor q-Axis Current at Previous Fault	394
Middle Output Frequency Voltage	174	Motor q-Axis Inductance	178
Middle Output Frequency Voltage 2	174	Motor Rated Current	116, 117, 174, 177, 390, 455
Minimum KEB Time	220	Motor Rated Power	116, 176, 177, 390
Minimum Output Frequency	174	Motor Rated Slip	175
Minimum Output Frequency Voltage	174	Motor Rated Voltage	116, 117, 390
Minimum Output Voltage	258	Motor Rotates After the Drive Output is Shut Off	293
Minimum Wait Time for Sending Messages	420	Motor Rotates Faster Than the Frequency Reference	292
Minor Alarms	262	Motor Rotates in One Direction Only	291
Minor Fault	283	Motor Secondary Current (Iq)	397
Minor Fault and Alarm Displays	262	Motor Speed Error	263
Minor Faults	262	Motor Speed Fault	284
Minor Faults and Alarms	260, 262	Motor Stalls During Acceleration or With Large Loads	291
Model Number and Nameplate Check	29	Motor Stator Resistance	178
Model, Voltage Class, Capacity Mismatch	285	Motor Temperature Input Filter Time	212, 382
Modes	101	Motor Wiring	77
Molded Case Circuit Breaker	333	Mounting Hole	32, 33, 34, 35, 36, 37, 38
Momentary Overcurrent Protection	352	MP	81
Momentary Power Loss Minimum Baseblock Time	219, 383	Multi-Function Analog Input Selection Error	263, 281
Momentary Power Loss Operation Selection	214, 382	Multi-Function Analog Input Terminal Settings	202
Momentary Power Loss Recovery Unit	333	Multi-Function Analog Inputs	199
Momentary Power Loss Ride-Thru	214, 352	Multi-Function Analog Output Terminal AM Bias	205
Momentary Power Loss Ride-Thru Time	219, 382	Multi-Function Analog Output Terminal AM Gain	205
Momentary Power Loss Voltage Recovery Ramp		Multi-Function Analog Output Terminal AM Monitor	
Time	219, 383	Selection	205
Monitor Output	81	Multi-Function Analog Output Terminal AM Signal	
Monitor Parameters	253, 391	Level Selection	206
Most Recent Fault	394	Multi-Function Analog Output Terminal FM Bias	205
Motor 1 Parameters	174	Multi-Function Analog Output Terminal FM Gain	205
Motor Acceleration Time for Inertia Calculations	226, 384	Multi-Function Analog Output Terminal FM Monitor	
Motor Base Frequency	116, 117, 390	Selection	205
Motor Base Speed	117, 390	Multi-Function Analog Output Terminal FM Signal	
Motor Code Selection	177, 404	Level Selection	206
Motor Data Error	263, 283	Multi-Function Analog Outputs	205
Motor d-Axis Current at Previous Fault	394	Multi-Function Digital Input Terminal Settings	181
Motor d-Axis Inductance	178	Multi-Function Digital Inputs	80, 181
Motor Direction at Power Up when Using Operator	249, 389	Multi-Function Digital Output	81
Motor Does Not Rotate	290	Multi-Function Digital Output Terminal Settings	190
Motor Excitation Current (Id)	397	Multi-Function Digital Outputs	190
Motor Hunting and Oscillation Control Parameters	259	Multi-Function Input Selection Error	280
Motor Induction Voltage Constant 1	178	Multi-Function Input Setting Error	263
Motor Induction Voltage Constant 2	178	Multiple Drive Installation	45
Motor Iron Loss	117, 390	Multiple Drive Wiring	78
Motor Iron Loss for Torque Compensation	175	Multi-Step Speed Selection	165
Motor is Too Hot	291		
Motor Line-to-Line Resistance	175	<b>N</b>	
Motor No-Load Current	175	n Special Adjustments	387
Motor Overheat	262, 271, 278	Nameplate	29
Motor Overheat 1 (PTC input)	261	Navigating the Drive and Programming Modes	101
Motor Overheat 2 (PTC input)	261	ndAT	285
Motor Overheat Alarm (PTC Input)	270	NEMA 1 Kit	334
Motor Overheat Alarm Operation Selection	212, 382	NetRef/ComRef Function Selection	179
Motor Overheat Fault (PTC Input)	271	Network Termination	415
Motor Overheat Fault Operation Selection	212, 382	Node setup	181
Motor Overload	261, 271	Noise From the Drive or Output Lines When the Drive	
Motor Overload Estimate (oL1)	395	is Powered On	292
Motor Overload Protection Selection	209, 382, 455	No-Load Current Alarm	283
Motor Overload Protection Time	210, 382, 455	No-Load Current Error	263, 284
Motor Parameters	170	No-Load Operation	120
Motor Performance Fine-Tuning	258	No-Load Operation Test Run	120
Motor Poles	116	Notes on Motor Operation	20
Motor Protection	209	Notes on Rotational Auto-Tuning	114
Motor Protection Function	271	Notes on Stationary Auto-Tuning	114
Motor Protection Using a Positive Temperature		nSE	262

Number of Auto Restart Attempts	229, 385
Number of Motor Poles	117, 175, 177, 390
Number of PM Motor Poles	119
Number of Run Commands	395
Number of Run Commands Counter Initialization	251
Number of Speed Search Restarts	144
<b>O</b>	
oC	262, 269
oFA00	261, 269
oFA01	261, 269
oFA03 to oFA06	270
oFA10	270
oFA11	270
oFA12 to oFA17	270
oFA30 to oFA43	261, 270
oFb00	270
oFC00	270
Offset Frequency	169, 397
oH	261, 262, 270, 278
oH1	261, 270
oH2	262, 278
oH3	261, 262, 270, 278
oH4	261, 271
oH5	271, 278
oL1	261, 271
oL2	261, 271, 293
oL2 Characteristics Selection at Low Speeds	236, 386
oL3	261, 262, 271, 278
oL7	261, 272
oPE	280
oPE Fault Parameter	280, 393
oPE01	263, 280
oPE02	263, 280
oPE03	263, 280
oPE04	263, 280
oPE05	263, 281
oPE07	263, 281
oPE08	263, 281
oPE09	263, 281
oPE10	263, 281
oPE11	263, 281
oPE13	263, 281
oPE15	282
Open Loop Vector Control	292
Open Loop Vector Control for PM Motors	28
Open Loop Vector Control Mode Tuning Parameters	258
Operating with the Load Connected	121
Operation Error Displays	263
Operation Errors	260, 263
Operation Selection when Digital Operator is Disconnected	249, 389
Operation Status Monitors	253, 391, 397
Operation with Permanent Magnet Motors	109
Operator Connection Fault	261
Operator Programming Errors	280
Operator Related Settings	246, 388
oPr	261, 272
Option Card Communications Error	262
Option Card Connection Error at Option Port CN5-A	269
Option Card Connection Error at Option Port CN5-C	270
Option card connector (CN5-A)	39
Option card connector (CN5-B)	39
Option card connector (CN5-C)	39
Option card error occurred at option port CN5-A	270
Option Card External Fault	261, 267, 276
Option Card Fault at Option Port CN5-A	269
Option Card Fault at Option Port CN5-B	270
Option Card Installation	336
Option Communication Error	261, 265, 275
Option Frequency Reference	395
Option Settings	179
Option Unit Fault	261
Optional 24 V DC Power Supply Connector Cover	32, 33
Optional 24 V DC power supply connector cover	34, 35, 36
Options	331
Oscillation or Hunting	293
Output Current	392
Output Current 1 During Speed Search	143
Output Current Imbalance	268
Output Frequency	391
Output Frequency after Soft Start	393
Output Frequency at Previous Fault	393
Output Frequency is not as High as Frequency Reference	293
Output Frequency Reduction During Overheat Alarm	234
Output Frequency Resolution	352
Output Ground Fault Detection Selection	235, 386
Output Noise Filter	333
Output Phase Loss	261, 268
Output Phase Loss Protection	386
Output Phase Loss Protection Selection	235
Output Power	392
Output Power at Previous Fault	393
Output Terminal Status	392
Output Terminal Status at Previous Fault	394
Output Voltage at Previous Fault	393
Output Voltage Detection Fault	274, 279
Output Voltage Limit	244
Output Voltage Meter	333
Output Voltage Reference	392
Output Voltage Reference (Vd)	397
Output Voltage Reference (Vq)	397
ov	261, 262, 272, 278
ov Suppression Function Selection	383
Overcurrent	262, 269
Overcurrent Detection Gain	237, 386
Overexcitation Deceleration	242
Overexcitation Deceleration Gain	242, 269, 387
Overexcitation Operation Selection	243, 387
Overheat 1 (Heatsink Overheat)	270
Overheat Alarm Level	233, 385
Overheat Pre-Alarm Operation Selection	234, 385
Overload Protection	352
Overload Tolerance	350, 351
Overtorque 1	262, 278
Overtorque Detection 1	261, 271
Overtorque Detection Operation	231
Overvoltage	261, 262, 272
Overvoltage Protection	352
Overvoltage Suppression Function	225
Overvoltage Suppression Function Selection	225
<b>P</b>	
P Control	145
Parameter Access Level	122
Parameter Range Setting Error	280
Parameter Selection Error	263, 281
Parameter Setting Range Error	263
Parameter Settings	103
Parameters for KEB Ride-Thru	218
Parameters that Change with the Motor Code Selection	404
Parameters to Minimize Motor Hunting and Oscillation	259
PASS	263, 278
Password	122, 127

Password Setting	127	PM Stationary Auto-Tuning for Stator Resistance	113
Password Settings	122	Power Detection Filter Time	159
Peak Hold Current	395	Power Ratings (Three-Phase 200 V Class)	350
Peak Hold Output Frequency	395	Power Ratings (Three-Phase 400 V Class)	351
Performance Life	301	Powerboard Failure	266
Performance Life Monitors Maintenance Monitors	301	Powering Up the Drive	110
Periodic Inspection	300	Predefined V/f Patterns	171
Periodic Maintenance	301	Preface	14
Peripheral Devices	331	Preparing the Ends of Shielded Cables	84
Permanent Magnet Motor Control	109	Preset Reference Timing Diagram	166
PF	261, 272	Previous Fault	393
Phase Order Selection	136	PROFIBUS-DP Parameters	179, 180
Photocoupler and Contact Outputs	85	Programming Mode	101, 103
PI Accel/Decel Time	153	Proportional Gain Setting (P)	148
PI Block Diagram	147	PTC	211
PI Control	145	Pull-In Current	243, 387
PI Control Selection Error	263	Pull-In Current Compensation Time Constant	243, 272, 387
PI Control Selection Fault	281	Pull-In Current during Accel/Decel for PM	273
PI Feedback	396	Pull-In Current Level for PM Motor Tuning	119
PI Feedback High Detection Level	151	Pull-Out Detection	261
PI Feedback High Detection Time	151	Pulse Monitor Selection Error	281
PI Feedback Input Methods	146	Pulse Output Connection Using External Voltage Supply	86
PI Feedback Loss	261, 262, 268, 277	Pulse Output Connection Using Internal Voltage Supply	86
PI Feedback Loss Detection Selection	150	Pulse Train Input Bias	207
PI Feedback Low Detection Level	150	Pulse Train Input Filter Time	207
PI Feedback Low Detection Time	151	Pulse Train Input Gain	207
PI Fine Tuning	156	Pulse Train Input Minimum Frequency	208
PI Function Setting	148	Pulse Train Input Scaling	207
PI Input (feedback)	396	Pulse Train Input Terminal RP Function Selection	207
PI Input Limit	155	Pulse Train Input/Output	206
PI Monitors	253, 396	Pulse Train Monitor Scaling	208
PI Offset Adjustment	148	Pulse Train Monitor Selection	207
PI Output	396	<b>R</b>	
PI Output Fault	293	R-	81
PI Output Gain Setting	149	R+	81
PI Output Level Selection	149	R/L1	72
PI Output Limit	148	Radiated and Radio Frequency Noise	345
PI Output Lower Limit	155	Ramp to stop	133
PI Output Reverse Selection	149	Rated Current Depending on Carrier Frequency	164
PI Primary Delay Time Constant	148	Rated Current Setting Alarm	263, 283
PI Setpoint	396	Rated Output Capacity	350, 351
PI Setpoint Display Digits	155	Rated Output Current	350, 351
PI Setpoint Input Methods	146	Rated Slip Error	263, 284
PI Setpoint Scaling	153	Rated Voltage, Rated Frequency	350, 351
PI Setpoint Selection	153	rdEr	286
PI Setpoint User Display	155	READ	249
PI Setpoint Value	153	rEAd	286
PI Sleep Delay Time	152	Reading Drive MEMOBUS/Modbus Register Contents	423
PI Sleep Function Start Level	152	Reading Parameter Settings	286
PI Sleep/Snooze	151	Reattaching the Digital Operator	68
PM Motor Auto-Tuning Mode Selection	118	Reattaching the Front Cover	70
PM Motor Base Frequency	119	Reattaching the Terminal Cover on an IP00 Enclosure Drive	67
PM Motor Code	177	Reattaching the Terminal Cover on an IP20/NEMA Type 1 Enclosure Drive	66
PM Motor Code Selection	118	Reattaching the Top Protective Cover	71
PM Motor Control Tuning	243	REMOTE	106
PM Motor d-Axis Inductance	119	Removing the Cooling Fan (2A0169, 2A0211, 4A0139, 4A0165)	311
PM Motor Induced Voltage Constant	119	Removing the Digital Operator	68
PM Motor Parameter Settings	113	Removing the Fan Cover	305
PM Motor q-Axis Inductance	119	Removing the Front Cover	68
PM Motor Rated Current	118	Removing the Terminal Cover on an IP00 Enclosure Drive	62, 67
PM Motor Rated Power	118	Removing the Terminal Cover on an IP20/NEMA Type 1 Enclosure Drive	66
PM Motor Rated Voltage	118		
PM Motor Settings	176		
PM Motor Stator Resistance	119		
PM Motor Type	118		
PM Speed Feedback Detection Suppression Gain	272		
PM Stationary Auto-Tuning	113		

Removing the Top Protective Cover	71	Side-by-Side Installation	45
Replacement Parts	301	Side-by-Side Mounting	355
Replacing the Drive	328	Side-by-Side Setup	45
Reset Communication Parameters	180	Simple Motor Setup Using V/f Control	108
Resistance Tuning Error	283	Simplified Setup Using the Setup Group	104
Response Messages from Drive to Master	420	SI-N3	334
REV LED Light	97	Single Drive KEB Ride-Thru 1	215
Reverse Direction Output Example Time Chart	196	Single Drive KEB Ride-Thru 2	215
Reverse Operation Selection	135	Sinking/Sourcing Mode Selection for Hardwire Baseblock Inputs	85
Rotational Auto-Tuning	114	SI-P3	334
Rotational Auto-Tuning for V/f Control	113	SI-S3	334
RP	80	SI-T3	334
RS-422 Interface	415	Slave Address	421
RS-485 Interface	414	SN	80
RTS Control Selection	417	Soft Charge Bypass Relay Maintenance	395
Rubber Bushing	32	Soft Charge Bypass Relay Maintenance Time	277
Run Command at Power Up	137	Soft Charge Circuit Fault	262
Run Command Input Error	262	Soft CLA Selection	386
Run Command Method Selection	418	Soft Starter Speed Reference at Previous Fault	394
Run Command Selection	290, 361	Software Current Limit Selection	236
Run Command Selection 1	132	Software No. (Flash)	393
Run Command Selection 2	137	Software No. (ROM)	393
Run Command Selection Error	263	Software version	29
Run command selection while in Programming Mode	136	SP	80
Run Command Source Selection	396	Space Between Drives (Side-by-Side Mounting)	45
Run Command/Frequency Reference Source Selection		Speed Agree 1 Time Chart	191
Error	281	Speed Agree 2 Time Chart	194
RUN LED	99	Speed Agreement Detection Level	227, 384
RUN LED and Drive Operation	99	Speed Agreement Detection Level (+/-)	227, 384
RUN LED Status and Meaning	99	Speed Agreement Detection Selection	228
RUN Light	97	Speed Agreement Detection Width	227, 384
<b>S</b>		Speed Agreement Detection Width (+/-)	227, 384
S-	81	Speed Control Range	352
S+	81	Speed Estimation Type Speed Search	140, 272
S/L2	72	Speed Feedback Detection Control Gain	243, 387
S1	80	Speed Feedback Detection Control Gain during ov	
S2	80	Suppression	245
S3	80	Speed Response	352
S4	80	Speed Search	139, 273
S5	80	Speed Search Deactivation Current	142
S6	80	Speed Search Deceleration Time	142
S7	80	Speed Search Delay Time	143
S8	80	Speed Search Detection Compensation Gain	143
Safety Hazard Definitions	15	Speed Search Estimation Type	271
Safety Information	15	Speed Search Method Selection	144
SC	80	Speed Search Restart Current Level	143
S-Curve Characteristics	162, 259	Speed Search Restart Detection Time	144
SE	263, 279	Speed Search Selection at Start	142
Search Operation Voltage Limit	159	Speed Search Wait Time	144
Self-diagnosing function of the serial communication interface circuits	436	Stall Prevention	221, 259, 272
SEr	261, 273	Stall Prevention Detection Time	227
Serial Communication Terminals	81	Stall Prevention during Deceleration	271
Serial Communication Transmission Error	262, 275	Stall Prevention Level during Acceleration	222, 383
Serial Communications Cable Connection Terminals (TB5)	414	Stall Prevention Level during Run	224, 383
Serial Communications Terminal and DIP Switch S2	415	Stall Prevention Limit during Acceleration	222, 383
Serviceable Parts	327	Stall Prevention Selection during Acceleration	221, 383
Setup Group	104	Stall Prevention Selection during Deceleration	223, 383
Setup Group Parameters	105	Stall Prevention Selection during Run	224, 383
Setup Mode	104	Standard Connection Diagram	58
Shielded Twisted-Pair Cables	84	Starting Torque	352
Short Circuit Brake Time at Start	139	Start-Up Flowcharts	107
Short Circuit Brake Time at Stop	139	Stationary Auto-Tuning	115
Short Circuit Braking Current	139	Stationary Auto-Tuning for Line-to-Line Resistance	113
SI-C3	334	Status Display	110
		STo	261, 273
		STOP button Input	263, 283
		STOP Key Function Selection	248, 389

Stopping Method after Communication Error	416	Troubleshooting	255
Stopping Method Selection	133	Troubleshooting without Fault Display	289
Storage Temperature	44	TrPC	279
Surge Protector	333	Tuning Errors	260
Switches and Jumpers on the Terminal Board	84	Types of Alarms, Faults, and Errors	260
Switching Between LOCAL and REMOTE	106	Types of Auto-Tuning for Induction Motors	113
<b>T</b>		Types of Auto-Tuning for Permanent Magnet Motors	113
T Motor Tuning	390	<b>U</b>	
T/L3	72	U Monitors	391
Target DC Bus Voltage for Overvoltage Suppression and Stall Prevention	225	U/T1	72
Task Complete	285	U2, U3 Initialization	251, 389
Temperature Derating	355	UL Standards	446
Terminal A1 Bias Setting	199	UL/cUL Mark	446
Terminal A1 Function Selection	199	UL3	261, 263, 273, 279
Terminal A1 Gain Setting	199	UL6	273
Terminal A1 Signal Level Selection	199	UnbC	273
Terminal A2 Bias Setting	201	Undertorque 1	263
Terminal A2 Function Selection	201	Undertorque Detection 1	261, 273, 279
Terminal A2 Gain Setting	201	Undertorque Detection Operation	231
Terminal A2 Input Signal Selection	86, 88	Undervoltage	261, 263, 279
Terminal A2 Signal Level Selection	201	Undervoltage 3	274
Terminal A3 Analog/PTC Input Selection	87	Undervoltage 3 (Soft-Charge Bypass Circuit Fault)	274
Terminal A3 Bias Setting	201	Undervoltage Detection Level (Uv)	383
Terminal A3 Function Selection	200	Undervoltage Detection Level (Uv1)	219
Terminal A3 Gain Setting	201	Undervoltage Protection	352
Terminal A3 Signal Level Selection	200	Unexpected Noise from Connected Machinery	293
Terminal AM/FM Signal Selection	87	Unit Code	248
Terminal Block Configuration	64	Unit Selection for MEMOBUS/Modbus Register 0025H	417
Terminal Board	32, 33, 34, 35, 36, 37, 38, 39, 327	Unstable Motor Speed when Using PM	294
Terminal Board Connection Error	266	Up/Down Command Operation	185
Terminal Board Connector	39	Up/Down Frequency Reference Limit Selection	168
Terminal Board not Connected	261, 266	USB Copy Unit	123, 334
Terminal Board Wiring	84	USB Port (type-B)	32
Terminal Board Wiring Guide	83	USB port (type-B)	33, 34, 35, 36, 37, 38, 89
Terminal Connections for Communication		User Monitor Selection after Power Up	246, 388
Self-Diagnostics	436	User Parameter Automatic Selection	122, 130, 360
Terminal Cover	32, 33, 34, 35, 66	User Parameter Default Value	122, 248, 389
Terminal cover	36, 37	User Parameters	122
Terminal Cover 2	36	User Parameters 1 to 32	122, 129, 360
Terminal Cover Screw	32	User Set Speed Agree 1 Time Chart	192
Terminal M1-M2 Function Selection	190	User Set Speed Agree 2 Example with a Positive L3-04 Value	195
Terminal M3-M4 Function Selection	190	User-Set Display Units Decimal Display	247
Terminal M5-M6 Function Selection	190	User-Set Display Units Maximum Value	247
Termination	87, 90	Using Braking Units in Parallel	341
Test Run	114, 115, 116, 120	Using the Pulse Train Output	86
Test Run Checklist	124	Uv	263, 279
Test Run with Load Connected	121	Uv1	261, 273
THo	273	Uv2	262, 274
Tightening Torque	73, 82	Uv3	262, 274
Timer Function Off-Delay Time	144	Uv4	274
Timer Function On-Delay Time	144	<b>V</b>	
Too Many Speed Search Restarts	261, 273	-V	80
Top Protective Cover	32, 71, 78	V/f Characteristics	352
Top Protective cover to prevent miswiring	39	V/f Control	28
Top Protective Covers, Reattaching	67	V/f Control Mode Tuning	258
Top Protective Covers, Removing	63, 66, 67	V/f Control Mode Tuning Parameters	258
Torque Compensation	162	V/f Data Setting Error	263, 281
Torque Compensation Gain	162, 258	V/f Gain During Speed Search	143
Torque Compensation Primary Delay Time	163, 258	V/f Pattern Default Values	399
Torque Detection	231	V/f Pattern Defaults	399
Torque Detection Level 1	232, 385	V/f Pattern Display Unit	247
Torque Detection Selection 1	231, 385	V/f Pattern for Motor 1	170
Torque Detection Time 1	232, 385	V/f Pattern Selection	170, 291
Torque Specifications, Three Phase 200 V Class	73	V/T2	72
Torque Specifications, Three Phase 400 V Class	75	vAEr	286


---

VERIFY	250
Verify Menu	104
Verifying Parameter Changes	104
vFyE	286
voF	274, 279
Voltage Class, Capacity Mismatch	286
Voltage Error Compensation Time Constant	244
vrFy	286
<b>W</b>	
W/T3	72
Warranty Information	23
Water Supply Pump Application	111
Watt Hour Output Example	199
Watt Hour Output Unit Selection	198
Watt Loss 200 V Class Three Phase Models	353
Watt Loss 400 V Class Three Phase Models	353
Wire Gauge, Three Phase 200 V Class	73
Wire Gauge, Three Phase 400 V Class	75
Wire Gauges	73, 82
Wiring Checklist	92
Wiring Diagram for 2-Wire Sequence	188
Wiring Distance	163
Wiring the Control Circuit Terminal	83
WRITE	250
Writing Parameter Settings	285
Writing to Multiple Registers	424
WrUn	279
<b>Z</b>	
Zero Phase Reactor	333
Zero-Speed Time Chart	191

## Revision History

The revision dates and the numbers of the revised manuals appear on the bottom of the back cover.



MANUAL NO. SIEP C710616 35B

Published in Japan October 2010 09-8 

└─ Date of publication

└─ Date of original publication

└─ Revision number

Date of Publication	Revision Number	Section	Revised Content
September 2011		Front cover	Revision: Format
		All	Revision: Reviewed and corrected entire documentation.
		Chapter 1	Revision: Nameplate
		Appendix D	Addition: Precautions for Korean Radio Waves Act Revision: · Wire Gauge and Torque Specifications · Closed-Loop Crimp Terminal Size
		Back cover	Revision: Address, format
October 2010		All	Addition: Larger drive capacities added along with corresponding data Three-phase 400V: CIMR-E□4A0930 and 4A1200 Revision: · Reviewed and corrected entire documentation. · Upgraded the software version to S8001.
August 2009	–	–	First Edition

# YASKAWA AC Drive E1000

## AC Drive for Fan and Pump

### Technical Manual

---

**DRIVE CENTER (INVERTER PLANT)**

2-13-1, Nishimiyaichi, Yukuhashi, Fukuoka, 824-8511, Japan  
Phone: 81-930-25-3844 Fax: 81-930-25-4369  
<http://www.yaskawa.co.jp>

**YASKAWA ELECTRIC CORPORATION**

New Pier Takeshiba South Tower, 1-16-1, Kaigan, Minatoku, Tokyo, 105-6891, Japan  
Phone: 81-3-5402-4502 Fax: 81-3-5402-4580  
<http://www.yaskawa.co.jp>

**YASKAWA AMERICA, INC.**

2121 Norman Drive South, Waukegan, IL 60085, U.S.A.  
Phone: (800) YASKAWA (927-5292) or 1-847-887-7000 Fax: 1-847-887-7310  
<http://www.yaskawa.com>

**YASKAWA ELÉTRICO DO BRASIL LTDA.**

Avenda Fagundes Filho, 620 Bairro Saude, São Paulo, SP04304-000, Brasil  
Phone: 55-11-3585-1100 Fax: 55-11-5581-8795  
<http://www.yaskawa.com.br>

**YASKAWA EUROPE GmbH**

Hauptstrasse 185, 65760 Eschborn, Germany  
Phone: 49-6196-569-300 Fax: 49-6196-569-398  
<http://www.yaskawa.eu.com>

**YASKAWA ELECTRIC UK LTD.**

1 Hunt Hill Orchardton Woods, Cumbernauld, G68 9LF, United Kingdom  
Phone: 44-1236-735000 Fax: 44-1236-458182  
<http://www.yaskawa.co.uk>

**YASKAWA ELECTRIC KOREA CORPORATION**

7F, Doore Bldg. 24, Yeoido-dong, Yeongdungpo-gu, Seoul, 150-877, Korea  
Phone: 82-2-784-7844 Fax: 82-2-784-8495  
<http://www.yaskawa.co.kr>

**YASKAWA ELECTRIC (SINGAPORE) PTE. LTD.**

151 Lorong Chuan, #04-01, New Tech Park, 556741, Singapore  
Phone: 65-6282-3003 Fax: 65-6289-3003  
<http://www.yaskawa.com.sg>

**YASKAWA ELECTRIC (SHANGHAI) CO., LTD.**

No. 18 Xizang Zhong Road, 17F, Harbour Ring Plaza, Shanghai, 200001, China  
Phone: 86-21-5385-2200 Fax: 86-21-5385-3299  
<http://www.yaskawa.com.cn>

**YASKAWA ELECTRIC (SHANGHAI) CO., LTD. BEIJING OFFICE**

Room 1011, Tower W3 Oriental Plaza, No. 1 East Chang An Ave.,  
Dong Cheng District, Beijing, 100738, China  
Phone: 86-10-8518-4086 Fax: 86-10-8518-4082

**YASKAWA ELECTRIC TAIWAN CORPORATION**

9F, 16, Nanking E. Rd., Sec. 3, Taipei, 104, Taiwan  
Phone: 886-2-2502-5003 Fax: 886-2-2505-1280




YASKAWA ELECTRIC CORPORATION

In the event that the end user of this product is to be the military and said product is to be employed in any weapons systems or the manufacture thereof, the export will fall under the relevant regulations as stipulated in the Foreign Exchange and Foreign Trade Regulations. Therefore, be sure to follow all procedures and submit all relevant documentation according to any and all rules, regulations and laws that may apply.

Specifications are subject to change without notice for ongoing product modifications and improvements.

© 2009-2011 YASKAWA ELECTRIC CORPORATION. All rights reserved.

MANUAL NO. SIEP C710616 35C

Published in Japan September 2011 09-8   
10-10-6