

Push-button Type Photomicro Sensors



BS5-P Series

For your safety, read and follow the considerations written in the instruction manual, other manuals and Autonics website.

The specifications, dimensions, etc. are subject to change without notice for product improvement. Some models may be discontinued without notice.

Features

- Button operation enables accurate detection regardless of material, color, or reflectance of target object
- "Optimized for transport detection of semiconductor wafer enclosures (FOUP, FOSB, etc.)"
- Optical detection of button operation guarantees 5 million operations of the mechanical life cycle
- Total of 4 red LED indicators (side:2, top:2) for higher visibility of operation status
- Increased product durability with steel mounting brackets
- Emitter OFF function and check stable operation functions
- Built-in reverse polarity protection circuit and output short overcurrent protection circuit

Safety Considerations

- Observe all 'Safety Considerations' for safe and proper operation to avoid hazards.
- ⚠ symbol indicates caution due to special circumstances in which hazards may occur.

⚠ Warning Failure to follow instructions may result in serious injury or death.

- 01. Fail-safe device must be installed when using the unit with machinery that may cause serious injury or substantial economic loss. (e.g., nuclear power control, medical equipment, ships, vehicles, railways, aircraft, combustion apparatus, safety equipment, crime/disaster prevention devices, etc.)**
Failure to follow this instruction may result in personal injury, economic loss or fire.
- 02. Do not use the unit in the place where flammable/explosive/corrosive gas, high humidity, direct sunlight, radiant heat, vibration, impact or salinity may be present.**
Failure to follow this instruction may result in explosion or fire.
- 03. Do not disassemble or modify the unit.**
Failure to follow this instruction may result in fire.
- 04. Do not connect, repair, or inspect the unit while connected to a power source.**
Failure to follow this instruction may result in fire.
- 05. Check 'Connections' before wiring.**
Failure to follow this instruction may result in fire.

⚠ Caution Failure to follow instructions may result in injury or product damage.

- 01. Use the unit within the rated specifications.**
Failure to follow this instruction may result in fire or product damage.
- 02. Use a dry cloth to clean the unit, and do not use water or organic solvent.**
Failure to follow this instruction may result in fire.

Cautions during Use

- Follow instructions in 'Cautions during Use'. Otherwise, It may cause unexpected accidents.
- When connecting an inductive load such as DC relay or solenoid valve to the output, remove surge by using diodes or varistors.
- Use the product after 0.1 sec of the power input.
When using a separate power supply for the sensor and load, supply power to the sensor first.
- 12-24 VDC \equiv model power supply should be insulated and limited voltage/current or Class 2, SELV power supply device.
- Wire as short as possible and keep it away from high voltage lines or power lines to prevent surge and inductive noise.
- When using switching mode power supply (SMPS), ground F.G. terminal and connect a condenser between 0V and F.G. terminal to remove noise.
- When using a sensor with a noise-generating equipment (e.g., switching regulator, inverter, and servo motor), ground F.G. terminal of the equipment.
- This unit may be used in the following environments.
 - Indoors (in the environment condition rated in 'Specifications')
 - Altitude max. 2,000 m
 - Pollution degree 2
 - Installation category II

Ordering Information

This is only for reference.

For selecting the specified model, follow the Autonics website.

BS 5 - P 1 M ① - ②

① Operation mode

L: Light ON (Unpressed button, indicator + output ON)

D: Dark ON (Pressed button, indicator + output ON)

② Control output

No mark: NPN open collector output

P: PNP open collector output

Cautions during Installation

- Be sure to install this product by following the usage environment, location, and specified ratings. Consider the listed conditions below.
 - Installation environment
 - Button stop position, output switching position, and operation limit position
 - Operation load
- Use the M3 flat head screw to install, tighten with a torque of 0.59 N m or less.
- Do not impact with a hard object or bend the cable excessively. That could decrease the product's water resistance.
- Do not pull the cable with a tensile strength of 30 N or over. Failure to follow this instruction may result in fire due to the open circuit.
- Use this product after the test. Check whether the indicator works appropriately for the positions of the detectable object.
- On the non-flush surface, install this product after inserting a spacer, as shown in [Fig. 1].

[Fig. 1]

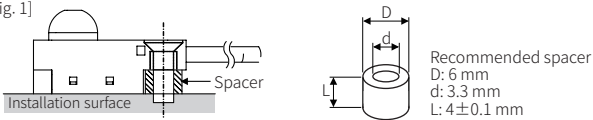

Operation timing chart

Operation mode	Light ON	Dark ON
Button	Pressed Unpressed	Pressed Unpressed
Received light	Received Interrupted	Received Interrupted
Operation indicator (red)	ON OFF	ON OFF
Transistor output	ON OFF	ON OFF

Connections

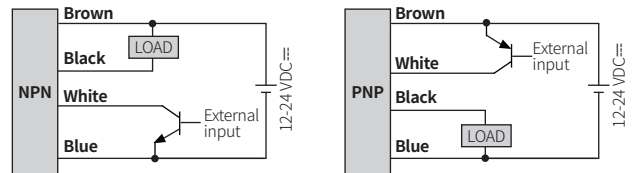

External Input Functions

You can connect the control wire (white) to an external device for the emitter OFF and check stable operation function

- Be sure to use a transistor that opens and closes 50 mA/10 V, and over 1/8 W resistors. Failure to follow this instruction may result in product damage.
- If the functions are not used, insulate the control wire (white).

■ Emitter OFF function

When the signal input occurs without pressing the button, you can check the receiver's operation by stopping the emitter.

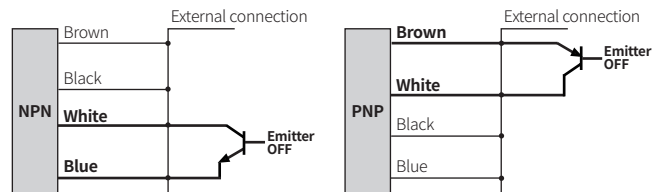

■ Check stable operation function

Without pressing the button, it reduces the LED intensity by about 20% and checks that the receiver is still receiving light (transistor ON). It helps to check in advance for malfunctions due to a decrease in the LED intensity.

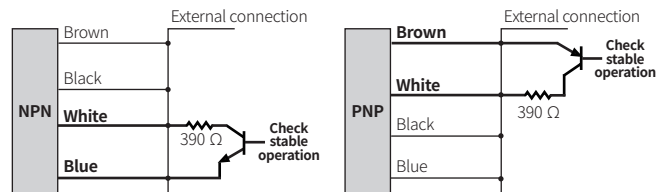

■ Emitter OFF function+ Check stable operation function

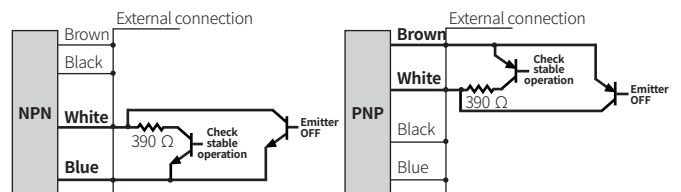

Inner Circuit

■ NPN open collector output

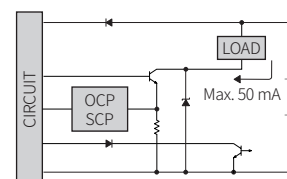

■ PNP open collector output

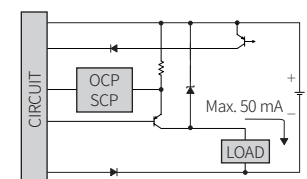

- OCP (over current protection), SCP (short circuit protection)
- If short-circuit the control output terminal or supply current over the rated specification, normal control signal is not output due to the protection circuit.

Dimensions

- Unit: mm, For the detailed drawings, follow the Autonics website.

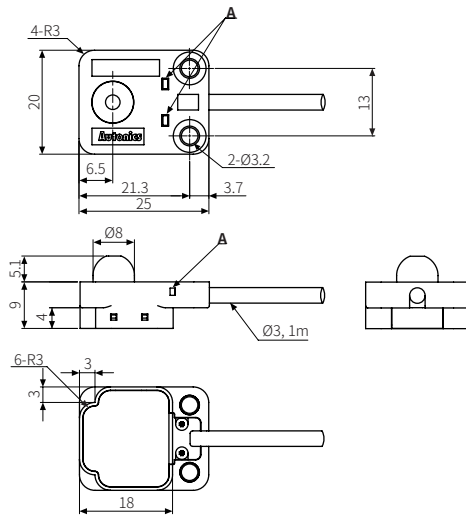

A Operation indicator (red)

Specifications

Model	BSS-P1M□-□
Sensing type	Push button type
Button stop position ⁰¹⁾	5.0 ± 0.4 mm
Button output switching position ⁰¹⁾	4.0 ± 0.5 mm
Button operation limit position ⁰¹⁾	≤ 0 mm
Operation load ⁰²⁾	≤ 3 N
Light source	Infrared LED
Peak emission wavelength	940 nm
Emitter OFF	YES (External input ⁰²⁾)
Check stable operation	YES (External input ⁰²⁾)
Operation mode	Light ON (Unpressed button, indicator + output ON) / Dark ON (Pressed button, indicator + output ON) mode model
Indicator	Operation indicator (red)
Approval	CE ENEC
Weight (packaged)	≈ 30 g (≈ 50 g)

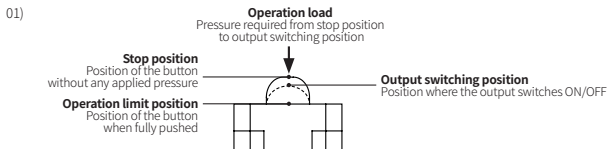

02)

External input	NPN output	PNP output
Emitter OFF	Short at 0 V or ≤ 0.25 VDC≐ (outflow current ≤ 30 mA)	Short at +V or +V ≥ -0.25 VDC≐ (absorption current ≤ 30 mA)
Emitter ON	Open (leakage current ≤ 0.4 mA)	Open (leakage current ≤ 0.4 mA)
Response time	≤ 1 ms	

Power supply	12-24 VDC≐ ± 10 % (ripple P-P: ≤ 10 %)
Current consumption	≤ 35 mA
Control output	NPN open collector output / PNP open collector output model
Load voltage	≤ 26.4 VDC≐
Load current	≤ 50 mA
Residual voltage	NPN: ≤ 1.5 VDC≐, PNP: ≤ 1.5 VDC≐
Protection circuit	Reverse power protection circuit, output short overcurrent protection circuit
Insulation resistance	≥ 20 MΩ (250 VDC≐ megger)
Noise immunity	The square wave noise (pulse width: 1 μs) by the noise simulator ± 240 VDC≐
Dielectric strength	1,000 VAC~ at 50/60 Hz for 1 min
Vibration	1.5 mm amplitude at 10 to 55 Hz frequency in each X, Y, Z direction for 2 hours
Shock	500 m/s ² (≈ 50 G) in each X, Y, Z direction for 3 times
Mechanical life cycle	≥ 5,000,000 operations (1 operation = stop position - operation limit position - stop position)
Ambient illumination	Fluorescent lamp: ≤ 1,000 lx (receiver illumination)
Ambient temperature	-20 to 55 °C, storage: -25 to 70 °C (a non freezing or condensation environment)
Ambient humidity	35 to 85 %RH, storage: 35 to 85 %RH (a non freezing or condensation environment)
Protection structure	IP40 (IEC standard)
Connection method	Cable type
Cable	Ø 3 mm, 4-wire, 1 m
Core	AWG28 (0.08 mm, 19-core), insulator outside diameter: Ø 0.88 mm
Material	Case: PC + G, button: POM, sleeve: SUS304