

Drive: 1/4" = 6.35mm HEX DRIVE
DIN3126-E6.3



For:

AEG, ARO, ATLAS-COPCO, BIAH, B&D, BOSCH, BUCKEYE-TOOLS, CHICAGO-PNEUMATIC, CLECO, DEPLAG, DESOUTTER, GARDNER-DENVER, HIOS (FERRA TOOLS), HITACHI, INGERSOLL, IWEMA, KELLER, MAKITA, MALL, METABO, NPK, PNEUTEC, ROCKWELL, ROTOR-TOOL, SKIL, STANLEY, THOR, URYU, VAN-DORN, VIRAX, WOLF, YOKOTA, YUTANI

POWER BITS

EDP No.	Model No.	PH	ϕD	ℓ	L
446126	B35 +00x1.2x20x60	00	1.2	20	60
446423	B35 +00x1.58x49 (10600)	00	1.58	-	49
446141	B35 +00x2x40x100	00	2	40	100
446145	B35 +0x1.4x30x60	0	1.4	30	60
446153	B35 +0 x2x20x60	0	2	20	60
446157	B35 +0 x2x30x100	0	2	30	100
487195	B35 +0x3.17x49 (1060)	0	3.17	-	49
424036	B35 +1x4.5x75x100	1	4.5	75	100
487202	B35 +1x4.76x89 (1081)	1	4.76	-	89
424038	B35 +2x4.5x75x100	2	4.5	75	100
489673	B35 +2x6x150 (4302/150)	2	6	-	150
446439	B35 +2x6x200 (4302/200)	2	6	-	200

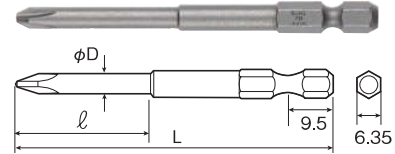

EDP No.	Model No.	heat treatment	PH	L
424032	B35 +1x50H	H	1	50
424034	B35 +1x75X	X	1	75
424035	B35 +1x75H	H	1	75
424061	B35 +2x50X	X	2	50
424040	B35 +2x50G	G	2	50
424062	B35 +2x75X	X	2	75
424047	B35 +2x75H	H	2	75
424041	B35 +2x75G	G	2	75
424042	B35 +2x75E	E	2	75
424048	B35 +2x100H	H	2	100
424043	B35 +2x100G	G	2	100
424044	B35 +2x100E	E	2	100
424049	B35 +2x150H	H	2	150
424045	B35 +2x150G	G	2	150
424046	B35 +2x150E	E	2	150
424050	B35 +3x75H	H	3	75
424051	B35 +3x75E	E	3	75
424052	B35 +3x100H	H	3	100
424053	B35 +3x100E	E	3	100
424054	B35 +3x150G	G	3	150

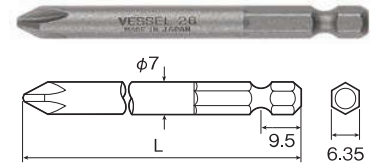

EDP No.	Model No.	heat treatment	PH	L
424131	B39 +1x23H	H	1	23
424141	B39 +2x23H	H	2	23
424143	B39 +2x40H	H	2	40
424147	B39 +2x100H	H	2	100

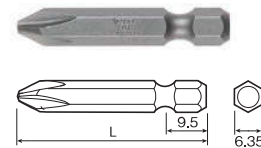

Drive: 1/4" = 6.35mm HEX DRIVE
DIN3126-E6.3



For:

AEG, ARO, ATLAS-COPCO, BIA, B&D, BOSCH, BUCKEYE-TOOLS, CHICAGO-PNEUMATIC, CLECO, DEPLAG, DESOUTTER, GARDNER-DENVER, HIOS (FERRA TOOLS), HITACHI, INGERSOLL, IWEMA, KELLER, MAKITA, MALL, METABO, NPK, PNEUTEC, ROCKWELL, ROTOR-TOOL, SKIL, STANLEY, THOR, URYU, VAN-DORN, VIRAX, WOLF, YOKOTA, YUTANI

POWER BITS

EDP No.	Model No.	w	t	L
424075	B35 -6x75	6	0.8	75
487245	B35 -6.35x49 (1524)	6.35	0.91	49
487255	B35 -7.9x49 (1526)	7.9	1.17	49

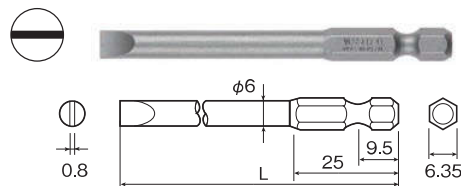

EDP No.	Model No.	heat treatment	H	L
424080	B35 H2x75H	H	2	75
424081	B35 H2x100H	H	2	100
424082	B35 H2.5x75H	H	2.5	75
424083	B35 H2.5x100H	H	2.5	100
424093	B35 H2.5x150H	H	2.5	150
424084	B35 H3x75H	H	3	75
424085	B35 H3x100H	H	3	100
424094	B35 H3x150H	H	3	150
487282	B35 H4x49H (21204)	H	4	49
424086	B35 H4x75H	H	4	75
424087	B35 H4x100H	H	4	100
424095	B35 H4x150H	H	4	150
487283	B35 H5x49H (21205)	H	5	49
424088	B35 H5x75G	G	5	75
424089	B35 H5x100G	G	5	100
424096	B35 H5x150G	G	5	150
487284	B35 H6x49G (21206)	G	6	49
424090	B35 H6x75G	G	6	75

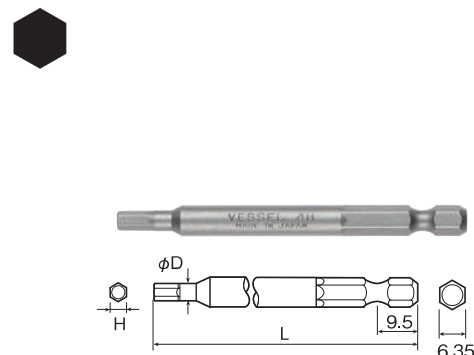

EDP No.	Model No.	PZ	phi D	L
424101	B35 PZ1x4.8x50	1	4.8	50
424102	B35 PZ2x6.3x50	2	6.3	50
424103	B35 PZ3x8.0x50	3	8.0	50

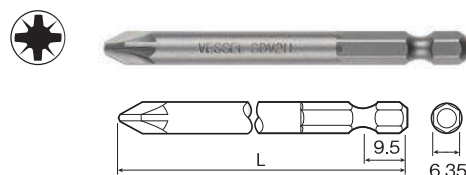

EDP No.	Model No.	SDV	L
636121	B35 SDV 1x75	1	75
636122	B35 SDV 2x75	2	75
636123	B35 SDV 2x100	2	100
636130	B35 SDV 3x75	3	75

