

A compact and accurate vertical limit switch. Type with a lamp which makes maintenance convenient; either a neon AC powered lamp or an LED DC powered lamp.

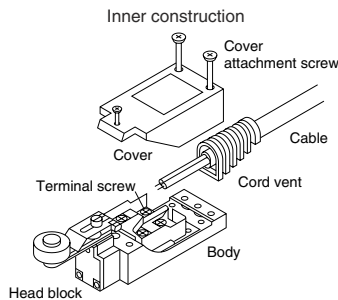

The cable can either be screwed in directly, or can use U-shaped and circular pressure terminals.



### 6. Lamp connection can be either spring type or lead wire type

- Spring type (wiring unnecessary) (With neon or LED lamp type)

Wiring is unnecessary because the lamp is directly connected to the terminals. By simply changing the direction of the lamp holder attachment, it is possible to display both lights during inoperability and during operation (however, if both NO and NC loads are connected, only the inoperability lamp can be displayed.)

Construction permits lamp attachment method to be changed.

## Characteristics

### 1. Compact design approximately 1/3 of the AZ5 limit switches

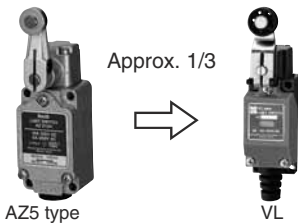

### 2. Au-clad contacts that can even use low level circuit and little chattering and bouncing

The built-in switch has Au-clad contacts with excellent contact reliability and uses a crossbar contact method, and moreover, has a dual cutoff circuit (1a1b contact) with little chattering and bouncing due to computer-operated analysis.

### 3. Easy wiring with full-open terminals

When the cover is removed, the terminals are open as far as the flank, so the necessity to insert your fingers into a case to complete the wiring has been removed. Moreover, the wiring space is large despite the compact size, and the terminals are spread in a tiered array, so that wiring work can be completed very easily.

### 4. Mounting are possible to both front and back

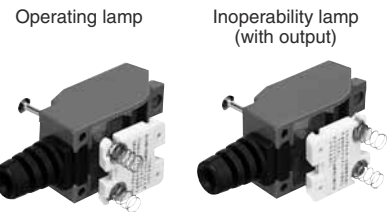
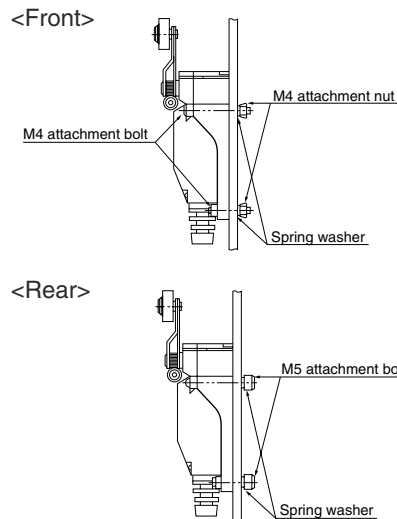

### • Lead wiring type <Current leakage 0> (LED lamp type only)

Because the wiring can be made parallel to the load, current leakage from the lamp can be reduced to 0. Even with a slight leak, the electronic circuit incurring the leak can be used safely.

### 7. Dust-proof, waterproof, oil resistant construction

The main unit and the cover are sealed with rubber packing, and the cord runner is doubly sealed by the cord vent. The actuator is sealed by both a rubber cap and an O ring in all models. Also, the lens and cover are formed simultaneously with the lamp type, and moreover, a nameplate is affixed to the upper surface, thereby improving the already excellent waterproof capabilities. (Note: Applications directly involving the cord entrance and the locations which are always wet and oily, or submersion in water or oil, cannot be used.)

### 5. Type with a lamp that can be used with a wide range of voltages

- With neon lamp  
Compatible with: **AC100 and 200V**;  
Even at AC 100V, sufficient luminosity is achieved through the diamond-cut lens. Also with a long lifespan of more than 20 thousand hours.
- With LED lamp  
Covers 6 to 48V DC and comes in three types, **6V DC**, **12V DC**, **24 to 48V DC**  
Uses two highly luminescent LEDs and in addition, sufficient luminosity is achieved through the diamond-cut lens.

## TYPICAL APPLICATIONS

Ideal for general plant facilities such as engineering machinery, conveyer machinery, and assembly lines  
LED lamp type is also compatible with low-voltage DC control circuits such as in PCs and computers.

## PRODUCT TYPE

### 1. Standard type

Actuator	Part No.
Push plunger	AZ8111
Roller plunger	AZ8112
Cross roller plunger	AZ8122
Roller arm	AZ8104
Adjustable roller arm	AZ8108
Adjustable rod	AZ8107
Flexible rod	AZ8166
Spring wire	AZ8169
Remote wire control plunger	AZ8181

Note) When ordering an overseas-specified product, refer to the Overseas Standards given below.

### 2. With Neon lamp

Lamp connection	Actuator	Lamp rating	Part No.
Spring type	Push plunger	100 to 200V AC	AZ811106
	Roller plunger		AZ811206
	Cross roller plunger		AZ812206
	Roller arm		AZ810406
	Adjustable roller arm		AZ810806
	Adjustable rod		AZ810706
	Flexible rod		AZ816606
	Spring wire		AZ816906
	Remote wire control plunger		AZ818106

Note) When ordering an overseas-specified product, refer to the Overseas Standards given below.

### 3. With LED

Lamp connection	Actuator	Lamp rating	
		12V DC	24 to 48V DC
		Part No.	
Spring type	Push plunger	AZ8111161	AZ811116
	Roller plunger	AZ8112161	AZ811216
	Cross roller plunger	AZ8122161	AZ812216
	Roller arm	AZ8104161	AZ810416
	Adjustable roller arm	AZ8108161	AZ810816
	Adjustable rod	AZ8107161	AZ810716
	Flexible rod	AZ8166161	AZ816616
	Spring wire	AZ8169161	AZ816916
	Remote wire control plunger	AZ8181161	AZ818116
Lead wire type	Push plunger	AZ8111661	AZ811166
	Roller plunger	AZ81122661	AZ811266
	Cross roller plunger	AZ8122661	AZ812266
	Roller arm	AZ8104661	AZ810466
	Adjustable roller arm	AZ8108661	AZ810866
	Adjustable rod	AZ8107661	AZ810766
	Flexible rod	AZ8166661	AZ816666
	Spring wire	AZ8169661	AZ816966
	Remote wire control plunger	AZ8181661	AZ818166

Notes) 1. LED rating 6V DC type is available. When ordering, add suffix 162(spring type) or 662(lead wire type) to the standard part No.

2. The DC24-48V rated lamp is recommended for PC input use.

### 4. Option

	Application	Part No.
VL limit conduit adapter	VL, VL with lamp, VL-T	AZ8801

## FOREIGN STANDARDS

Standard	Applicable product	Part No.
UL	File No. : E122222 Ratings : 5A 250V AC Pilot duty B300 Product type : Standard model, with neon lamp	Order by standard part No. However, add "9" to the end of the part No. for the model with neon lamp.
CSA	File No. : LR55880 Ratings : 5A 250V AC Pilot duty B300 Product type : Standard model, with neon lamp	
TÜV	File No. : J9551203 Ratings : AC-15 2A/250V~ Product type : Standard model only	Order by standard part No.

# SPECIFICATIONS

## 1. Rating

### 1) Standard type

Rated control voltage	Load	Resistive load (cos φ≐1)	Inductive load (cos φ≐0.4)
125V AC		5A	3A
250V AC		5A	2A
125V DC		0.4A	0.1A

### 2) Type with indicator

Types	Rated control voltage	Resistive load (cos φ≐1)	Inductive load (cos φ≐0.4)
With Neon lamp	125V AC	5A	3A
	240V AC	5A	2A
With LED	24V DC	3A	—

## 2. Characteristics

Contact arrangement	1 Form Z		
Initial contact resistance, max.	15mΩ (By voltage drop 6 to 8V DC at rated current)		
Contact material	Gold clad over silver		
Initial insulation resistance (At 500V DC)	Min. 100MΩ		
Initial breakdown voltage	1,000Vrms for 1 min Between non-consecutive terminals 2,000Vrms for 1 min Between dead metal parts and each terminal 2,000Vrms for 1 min Between ground and each terminal		
Shock resistance max.	In the free position	Max. 98m/s <sup>2</sup> {10G}	
	In the full operating position	Max. 294m/s <sup>2</sup> {30G}	
Vibration resistance	Standard type: Max. 55Hz Type with indicator: 10 to 50Hz, double amplitude of 1.5mm		
Expected life (Min. operations)	Mechanical	10 <sup>7</sup> (at 120 cpm)	
	Electrical	3×10 <sup>5</sup> (at rated resistive load) 5×10 <sup>5</sup> (Magnetic contactor FC-100 200V AC load)	
	Life of lamp	Min. 2×10 <sup>4</sup> hours (Neon lamp type)	
Ambient temperature/Ambient humidity	-20 to +60°C -4 to +140°F/Max. 95%		
Max. operating speed	120 cpm		

## 3. EN60947-5-1 performance

Item	Rating
Rated insulation voltage (Ui)	250VAC
Rated impulse withstand voltage (Uimp)	2.5kV
Switching overvoltage	2.5kV
Rated enclosed thermal current (Ithe)	5A
Conditional short-circuit current	100A
Short-circuit protection device	10A fuse
Protective construction	IP64
Pollution degree	3

## 4. Operating characteristics

Characteristics	O.F. (N {gf}) max.	R.F. (N {gf}) min.	Pretravel (P.T.), max. mm inch	Movement Differential (M.D.), max. mm inch	Overtravel (O.T.), min. mm inch	Totaltravel (T.T.), min. mm inch
Actuator						
Push plunger	8.83 {900}	1.47 {150}	1.5 .059	0.7 .028	4 .028	5.5 .217
Roller plunger						
Cross roller plunger						
Roller arm	5.88 {600}	0.49 {50}	20°	10°	75°	95°
Adjustable roller arm	7.84 {800}~3.35 {342}	0.49 {50}~0.21 {21}	20°	10°	75°	95°
Adjustable rod	7.84 {800}~1.99 {203}	0.49 {50}~0.12 {12}	20°	10°	75°	95°
Flexible spring wire	0.88 {90}	—	30 (1.181)	—	20 (.787)	50 (1.969)
Remote wire control plunger	19.61 {2,000}~24.52 {2,500}* 19.61 {2,000}~24.52 {2,500}*	1.96 {200}~1.96 {200}* 1.96 {200}~1.96 {200}*	1.5 .059 4 .157*	0.7 .028 2.0 .079*	4.5 .177 2.0 .079*	6 .236 6 .236*

\*Characteristics measured at bent condition: min. radius 100mm 3.937inch.

Notes) 1. Keep the total travel values in the specified range. Otherwise the actuator force may rise to several times the operating force, resulting in a mechanical failure or much shorter service life.  
2. For the operating characteristics, refer to the TECHNICAL INFORMATION.

## 5. Protective construction

Protective construction	VL mini limit SW	VL mini limit SW (with indicator)
IEC		
IP60	○	○
IP64	○	○

## 6.Lamp rating

Types	Rated operating voltage	Operating voltage range	Internal resistor
Neon lamp	100 to 200V AC	80 to 240V AC	120kΩ
	6V DC	5 to 15V DC	2.4kΩ
LED	12V DC	9 to 28V DC	4.7kΩ
	24 to 48V DC	20 to 55V DC	15kΩ

# DATA

## 1. Life curve

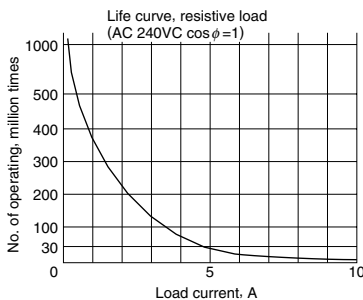

## 2. Actual load life curve (relay coil load)

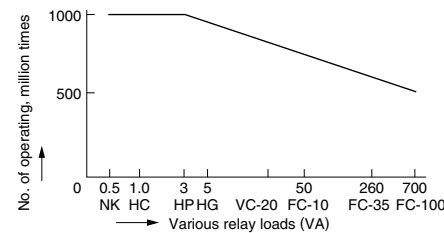

Note: The FC magnetic contactor series is 200V AC. The K is 2 Form C 24V DC type.

# WIRING DIAGRAM

## Output circuit

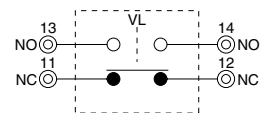

## Terminal

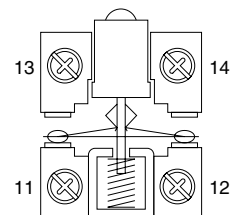

# DIMENSIONS

•Push plunger type

Standard type

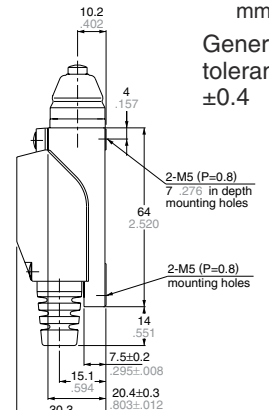
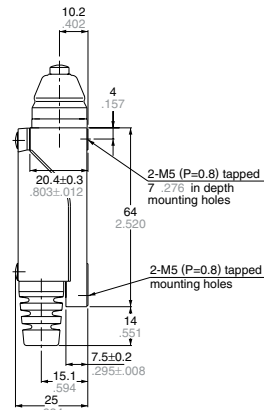
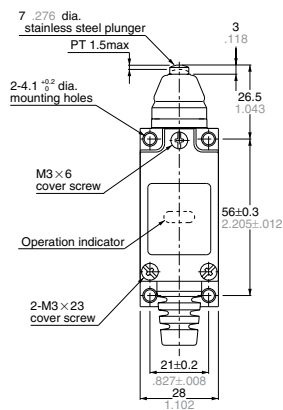

(Standard type)

(With Neon lamp)

mm inch  
General tolerance: ±0.4

•Roller plunger type

Standard type

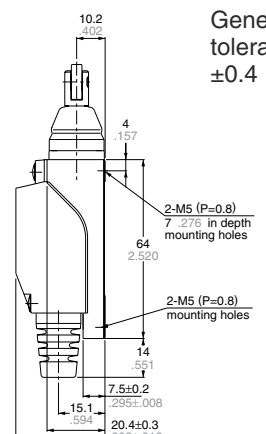
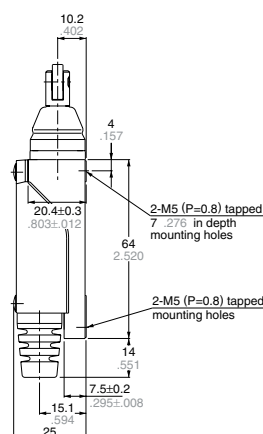
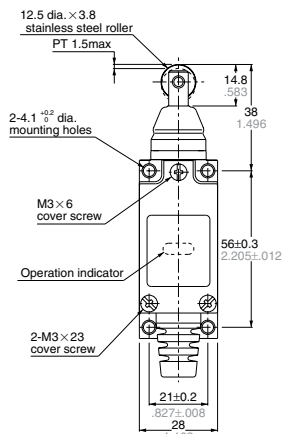

(Standard type)

(With Neon lamp)

General tolerance: ±0.4

•Cross roller plunger type

Standard type

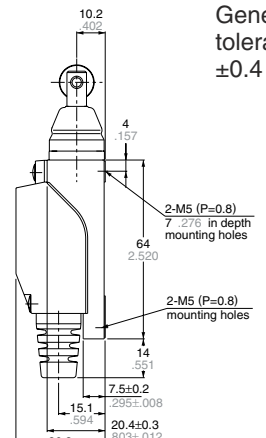
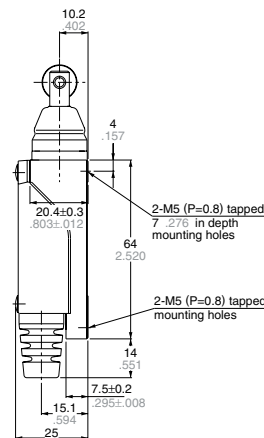
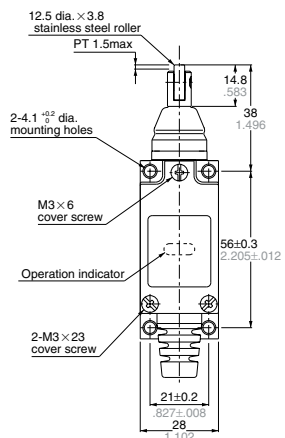

(Standard type)

(With Neon lamp)

General tolerance: ±0.4

•Roller arm type

Standard type

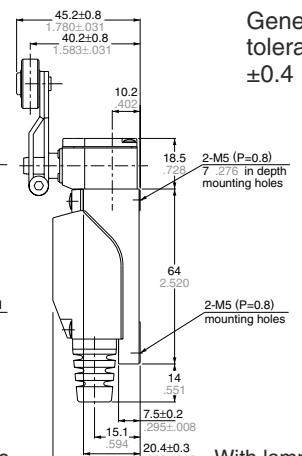
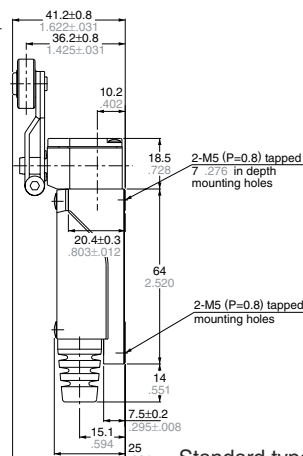
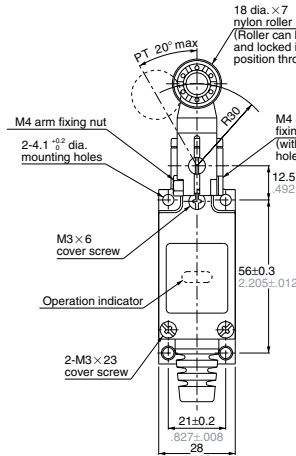

Standard type

With lamp

General tolerance: ±0.4

# VL (AZ8)

Including discontinued products (  )

## Adjustable rod type

### Standard type

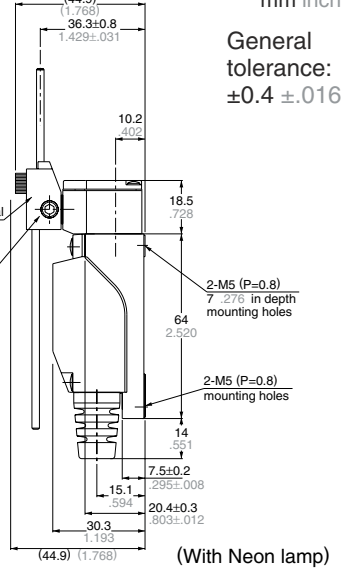
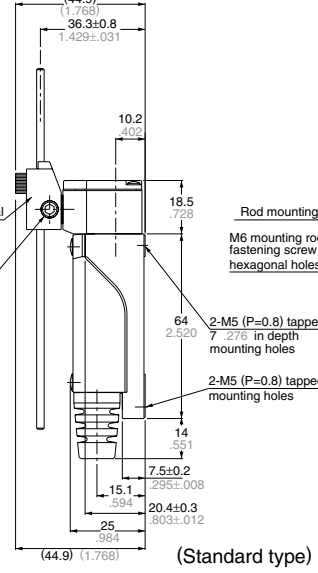
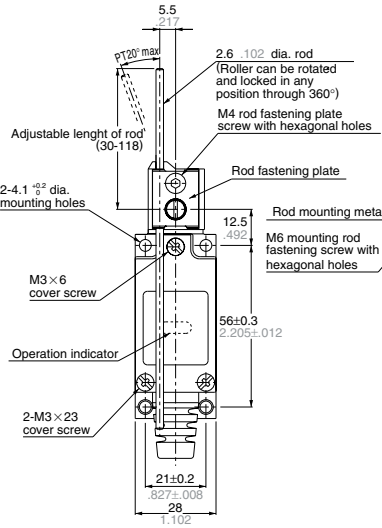

mm inch  
General tolerance: ±0.4 ±.016

## Adjustable roller arm type

(Length of arm can be adjustable within 30 to 70mm 1.181 to 2.756inch by 1mm .039inch pitch)

### Standard type

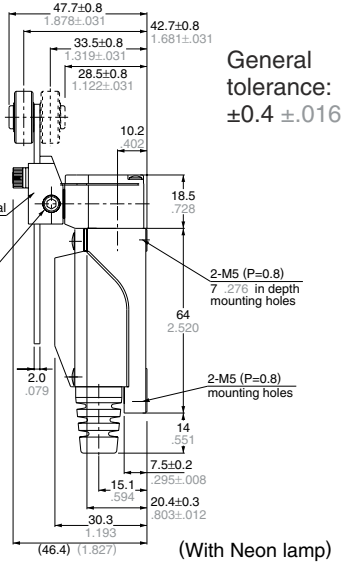
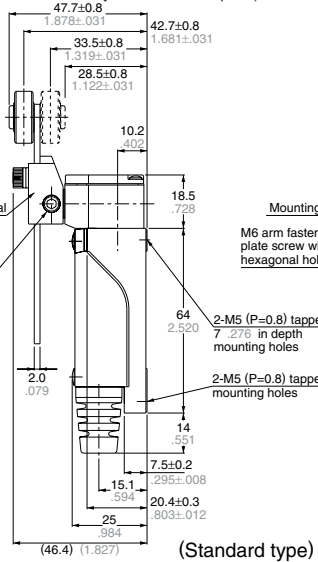
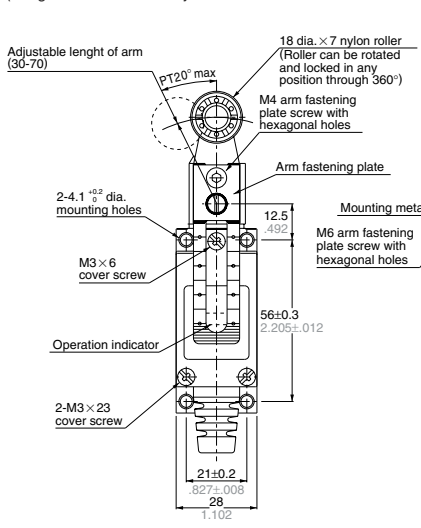

General tolerance: ±0.4 ±.016

## Flexible rod type (Should be used with less than 50mm 1.969inch of T.T.)

### Standard type

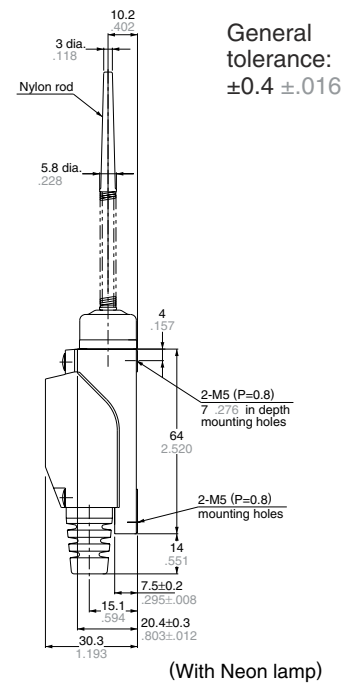
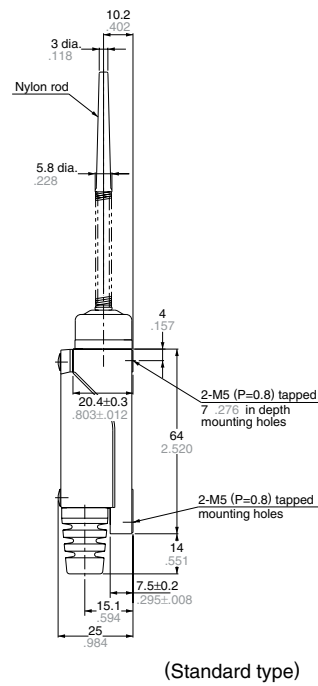
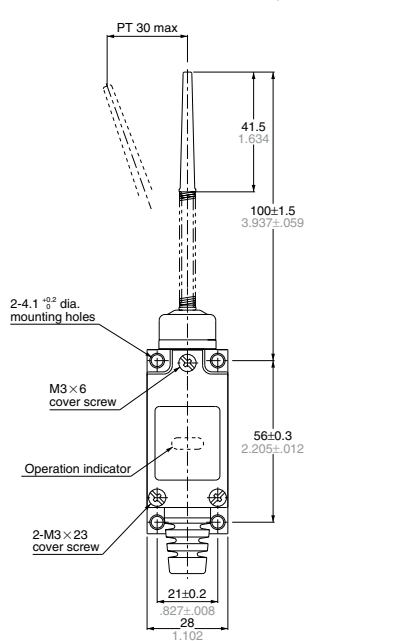

General tolerance: ±0.4 ±.016

•Spring wire type (Should be used with less than 50mm 1.969inch of T.T.)

Standard type

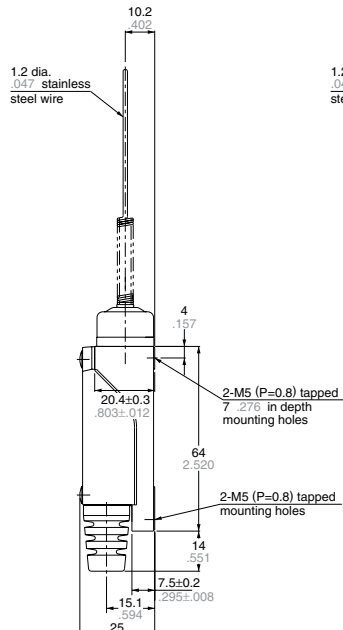
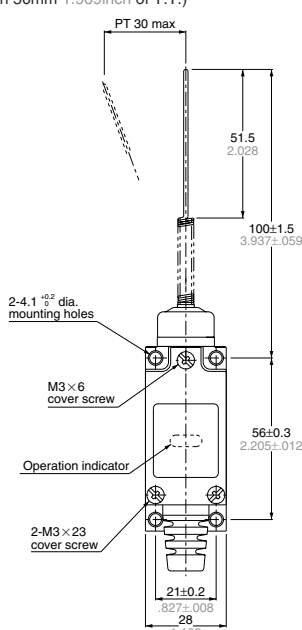

General tolerance: ±0.4 ±.016

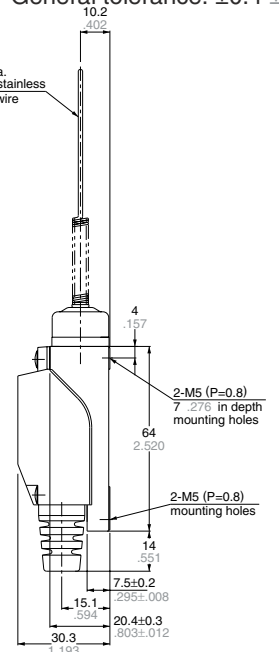

(Standard type)

(With Neon lamp)

•Remote wire control type

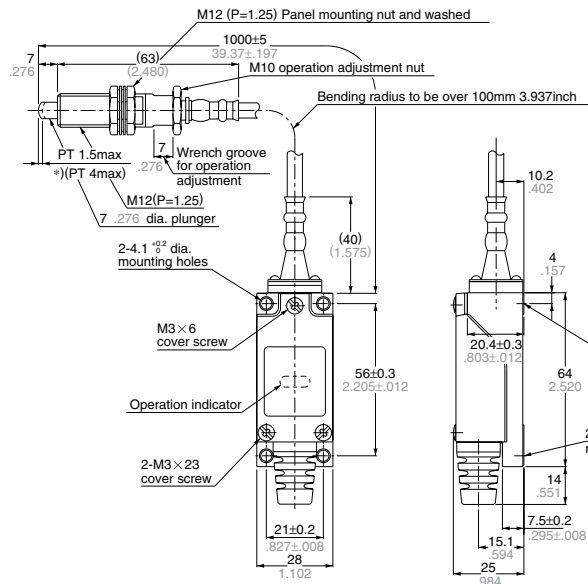

General tolerance: ±0.4 ±.016

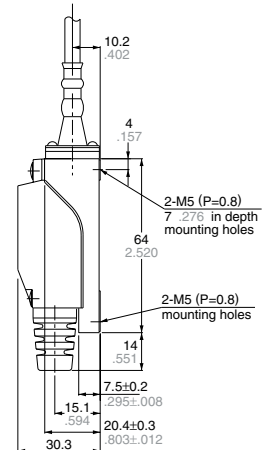
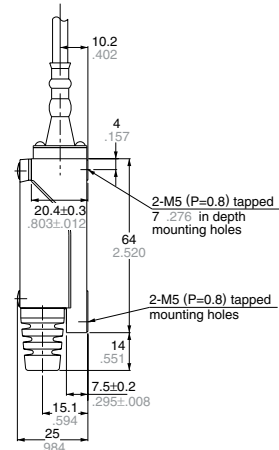

\*) 100 mm 3.937inch and the total bend comes to 360°

(Standard type)

(With Neon lamp)

**1. Mounting**

- 1) Fasten a switch body
- 2) Fasten a wire tentatively
- 3) Fasten an actuator
- 4) Fasten the wire

Note) When setting the operating position, it is recommended to adjust operation adjustment nut to keep safety margin for releasing.

**2. Actuator**

- 1) Make the hole (12.5±0.3mm .492±.012inch dia.) on the panel.
- 2) Fasten the actuator by a panel mounting nut and washer.

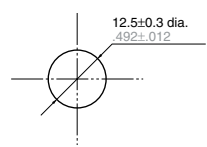

Panel thickness max. 10mm .394 inch

**3. Remote wire**

- 1) Use the wire in as rectilinear condition as possible.
- 2) When the wire is bent, the radius should be more than 100mm 3.937inch.
- 3) When fastening the wire, fasten the wire at the point more than 100mm 3.937inch as below;

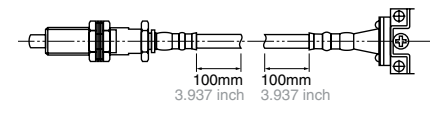

- 4) Less fastening points are recommended.
- 5) When the wire is fasten, use the rubber bushing to avoid to reform the diameter.
- 6) When the wire is bent, P.T., M.D. and O.T. can be adjustable as below;
  - P.T. = 2.5mm .098inch (max.)
  - M.D. = 1.5mm .059inch (max.)
  - O.T. = 3.5mm .138inch (min.)

**OPTION**

VL Conduit Adapter



AZ8801

• Applicable wire

Electric wire name	Finished outside diameter
Vinyl cabtire cord (VCTF)	8.7 to 11 dia.
Vinyl cabtire cable (VCT)	.343 to .433 dia.



(A set of mounting hex. socket screws is supplied.)

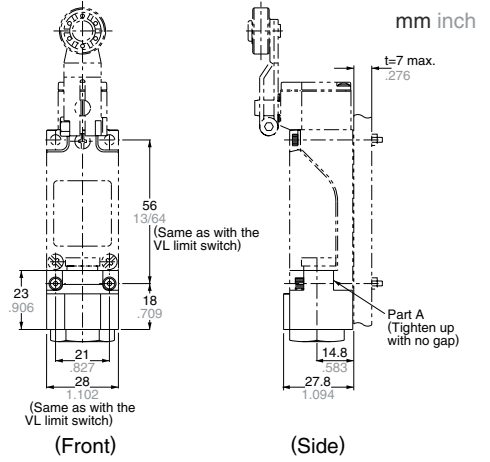

**INDICATOR LIGHTING CIRCUIT**

**1. Spring type**

1) When connecting load to N.O. side: When the switch is at free position, the indicator is lit, and when the switch operates, the indicator turns off. (Use the indicator holder in the same condition as when it was at the time of shipment.)

2) When connecting load to N.C. side: When connecting switch is at free position, the indicator turns off, and when the switch operates, the indicator is lit. (Use the lamp holder, changing it direction by 180°.)

3) When connecting loads to both N.O. and N.C. sides: Same as in 1). (Use the lamp holder in the same condition as when it was at the time of shipment. In this case, it is impossible to use it, changing its direction by 180°.)

(With Neon lamp)

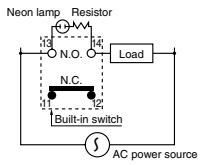

(With LED)

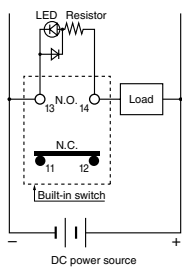

(With Neon lamp)

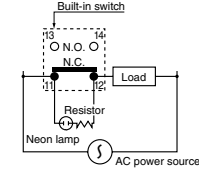

(With LED)

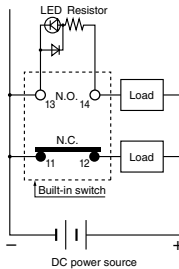

(With Neon lamp)

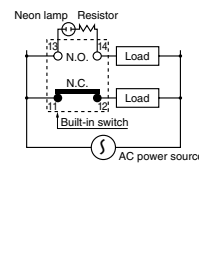

(With LED)

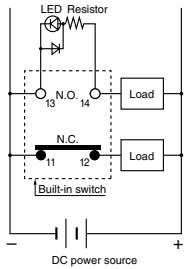

**2. Lead wire type (only for types with LED)**

1) When giving indication on N.O. side and N.C. side, operation is same as that in the case of the spring type. However, when load is connected to both N.O. side and N.C. side, indication can be given on both N.C. side and N.O. side.

2) When the indication circuit is connected with load in parallel: Load performs the same operation as the indication circuit does. (When load operates, the lamp is lit, and when load is turned off, the lamp goes out.)

- More loads than for one circuit cannot be controlled.
- There is no leakage current.

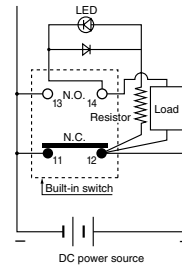

**MOUNTING DIMENSIONS**

Surface mounting

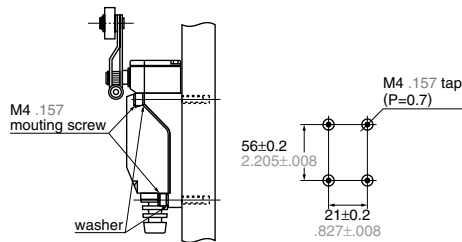

Depth of screw holes > 15mm .591inch

Through hole mounting

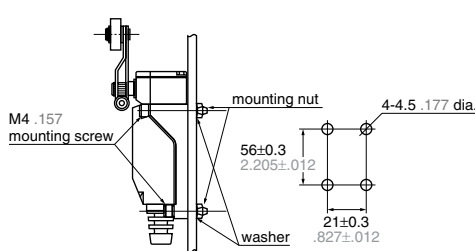

Thickness of panel < 5mm .197inch

Rear mounting

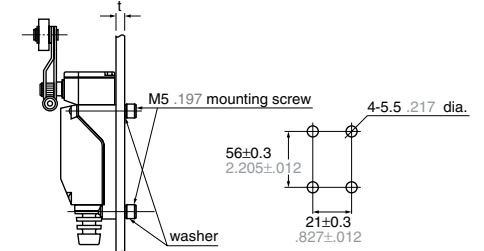

Length of bolt < panel thickness t+7mm .276inch

## WIRING mm inch

- Insulation distance more than 6.4mm .252inch for wiring and live parts
- Special assembly screws
- Grounding is available

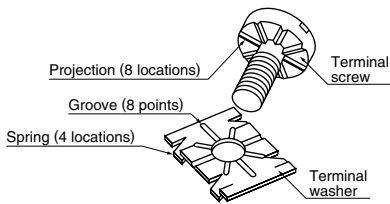

### Applicable fasten terminal

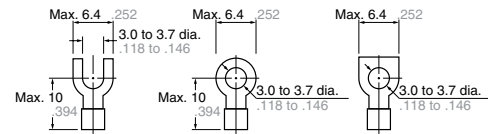

### With insulated grip

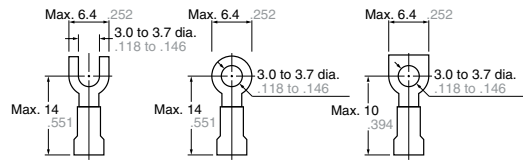

### Cable treatment Ordinary terminal

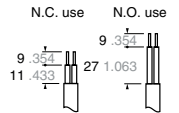

### Fasten terminal

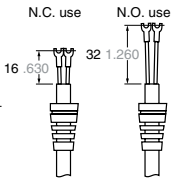

## Applicable wire

Wire name	Applicable wire		
	Wire-strand	Conductor	Finished outside diameter
Vinyl cabtire cord (VCTF)	2-wire	0.75mm <sup>2</sup> *1.25mm <sup>2</sup>	Round shape 6 dia. to 9 dia. Flat shape Max. 9.4
	3-wire	2.0mm <sup>2</sup>	
	4-wire	0.75mm <sup>2</sup> *1.25mm <sup>2</sup>	
Vinyl cabtire cable (VCT)	2-wire	0.75mm <sup>2</sup>	
600V vinyl insulation sealed cable (VVF)	2-wire	1.0 dia. to 1.2 dia.	
		1.6 dia.	

## Head direction change

(Roller arm, adjustable roller arm, adjustable rod types)

Actuator heads may be moved in 90° increments to any of four directions, by removing one screw.

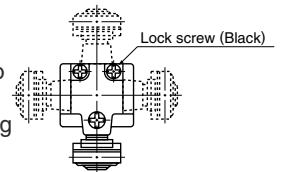

## CAUTIONS

1. When overtravel is too large, life is shortened due to possible damage to the mechanism. Please use in the following appropriate range.

Types	Overtravel
Plunger (AZ8111, 8112, 8122)	1.5 to 2.0mm .059 to .079inch
Roller Arm (AZ8104, 8107, 8108)	20 to 30°
Flexible Rod (AZ8166, 8169)	15 to 20mm .591 to .787inch (at the top)

2. Because these switches are not of immersion protected construction, their use in water or oil should be avoided. Also, locations where water or oil can normally impinge upon the switch or where there is an excessive accumulation of dust should be avoided.

5. Remote wire control types:

Because the main unit is not of water resistant or immersion-proof construction, their use in water or oil should be avoided. Also, locations where water or oil can normally impinge upon the switch or where there is an excessive accumulation of dust should be avoided. The main unit should be installed above the detection part in such case. (An actuator is immersion-protected construction.)

6. Mounting

Three cover screws should be fasten uniformly. The rubber for opening cord should be corrected as normal condition after connecting the wire.

7. How to change the indicator holder.

- 1) As shown in the photograph, wrench a minus-driver in the gap between the cover and the part of the indicator holder indicated by the arrow in the direction of insertion, and raise the lamp a little.
- 2) After removing the indicator holder, insert it in the reverse direction, and push it in until a snap is heard.

3. The use of these switches under the following conditions should be avoided. If the following conditions should become necessary, we recommend consulting us first.

- Use where there will be direct contact with organic solvents, strong acids or alkalis, or direct exposure to their vapors.
- Use where inflammable or corrosive gases exist.

4. In order to maintain the reliability at a high level under practical conditions of use, the actual operating conditions should be checked for the benefit of the quality of the product.

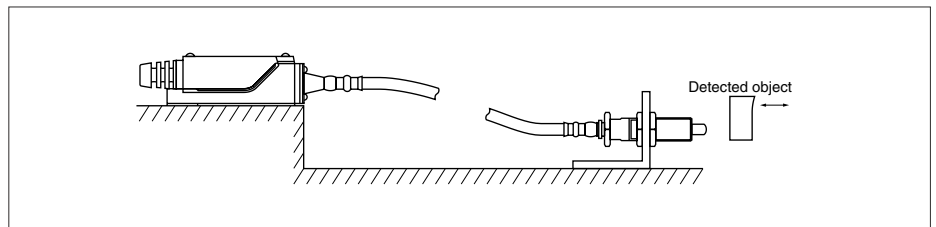

3) After changing the direction of the indicator holder, put the cover on it in such a way that the spring touches the top of the terminal screw.

(Unless the spring rests completely on the terminal screw, distortion of the spring, failure in lighting of the lamp or short circuit may result.)

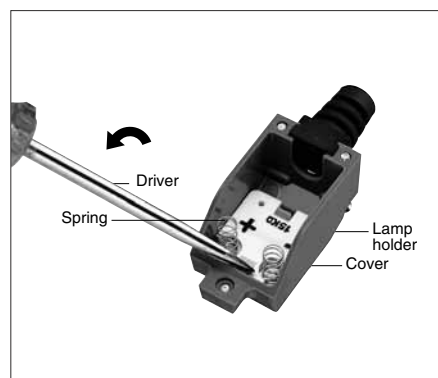

8. Matters to be attended to in using spring type VL Limit Switch with indicator.

- 1) When loads are connected to both N.O. and N.C. only the indication at non-operation time can be used.
- 2) Take special care not to damage or deform the contact spring during change of indicator holder direction or during connection work.
- 3) In the case of VL Limit Switch with Neon lamp, if the indicator is connected in series in a 100V circuit, the indicator ceases to be lighted. However, for a 200V circuit, up to 2 lamps can be connected in series.
9. Matters to be attended to in using lead wire type VL with lamp.
  - 1) When loads are connected to both N.O. and N.C. indication can be given on both N.O. and N.C. sides, but it is impossible to connect the indication circuit to the load in series.